

## Information for the Home Mechanic

---

### Electronic Mixture Controller Manual

This is one long page and should print out without any problems.

Saving this page won't automatically save the images so remember to save the images individually.

#### HOW THE SYSTEM WORKS

The car's computer is expecting to see an oscillating signal from the oxygen sensor which goes from zero volts to plus one volt approximately. The fuel flow is adjusted to maintain the average voltage at close to 0.5 volts

The signal from the sensor isn't a square wave, but more like a smooth triangular wave form. The computer doesn't care about the exact shape but simply tries to maintain the average.

**The Electronic Mixture Controller** is installed in the system between the oxygen sensor and the car's computer.

What this device does is convert the wave form into a square wave, but more importantly it sets up a threshold voltage that is lower than 0.5 volts. When the sensor output is above the threshold, which is set quite low, say 0.1 volts, then the device will send a high signal to the computer. When the sensor signal drops below the threshold the device signal out will be low. The computer adjusts the fuel flow accordingly and now is **actually maintaining the average voltage from the sensor at 0.1 Volts (100mV) instead of 0.5 volts. (500mV)**

From the Sensor Output graph you can see that the mixture is now slightly leaner than it was. The operating range is shifted to the right.

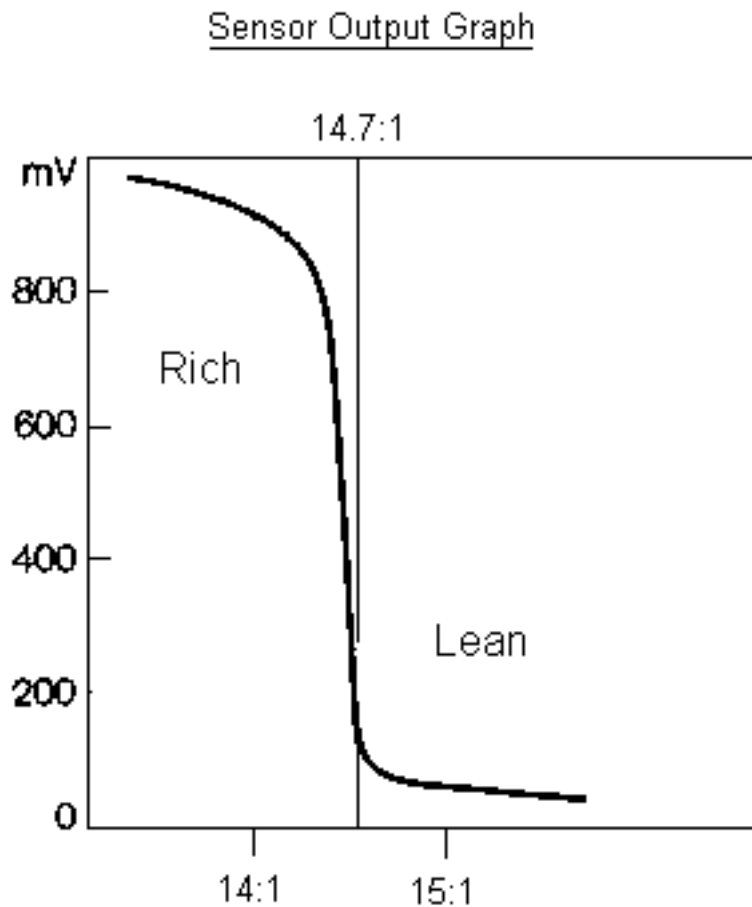

We have cut the fuel quantity by no more than a few percent, perhaps 5%. This by itself will produce some mileage improvement but not a lot. The greatest benefit occurs when applying the device in support of some other high mileage system. Especially cold vapor systems and water injection. The computer will normally fight these systems to compensate for the added exhaust oxygen. This device fools the computer and enables the maximum possible mileage improvements.

If your oxygen sensor is old and sluggish this device will also improve the reaction time. Because it instantly tells the computer when the sensor output is below or above the threshold, there is less overshoot. Smaller, quicker corrections to the mixture occur rather than long slow corrections.

## CIRCUIT DESCRIPTION

The heart of the circuit is the LM3914 linear LED dot/bar Driver IC, which we operate in bar mode. This is the same IC as is in the Mixture Display circuit. We set the sensitivity to 500mV full scale for this controller.

If you want to be able to adjust your mixture richer for more power rather than leaner then you should adjust the sensitivity to a greater voltage, around 700mV. It is not recommended to set the threshold too high, because it is quite possible that your sensor output may never reach that

high. The computer will keep adding fuel expecting the signal to go high. Remember, excess fuel will be burnt inside the catalytic converter which could cause a meltdown. Don't risk a fire under your seat. Or it may simply ignore the sensor and operate in open loop mode.

### Electronic Mixture Controller Circuit Diagram

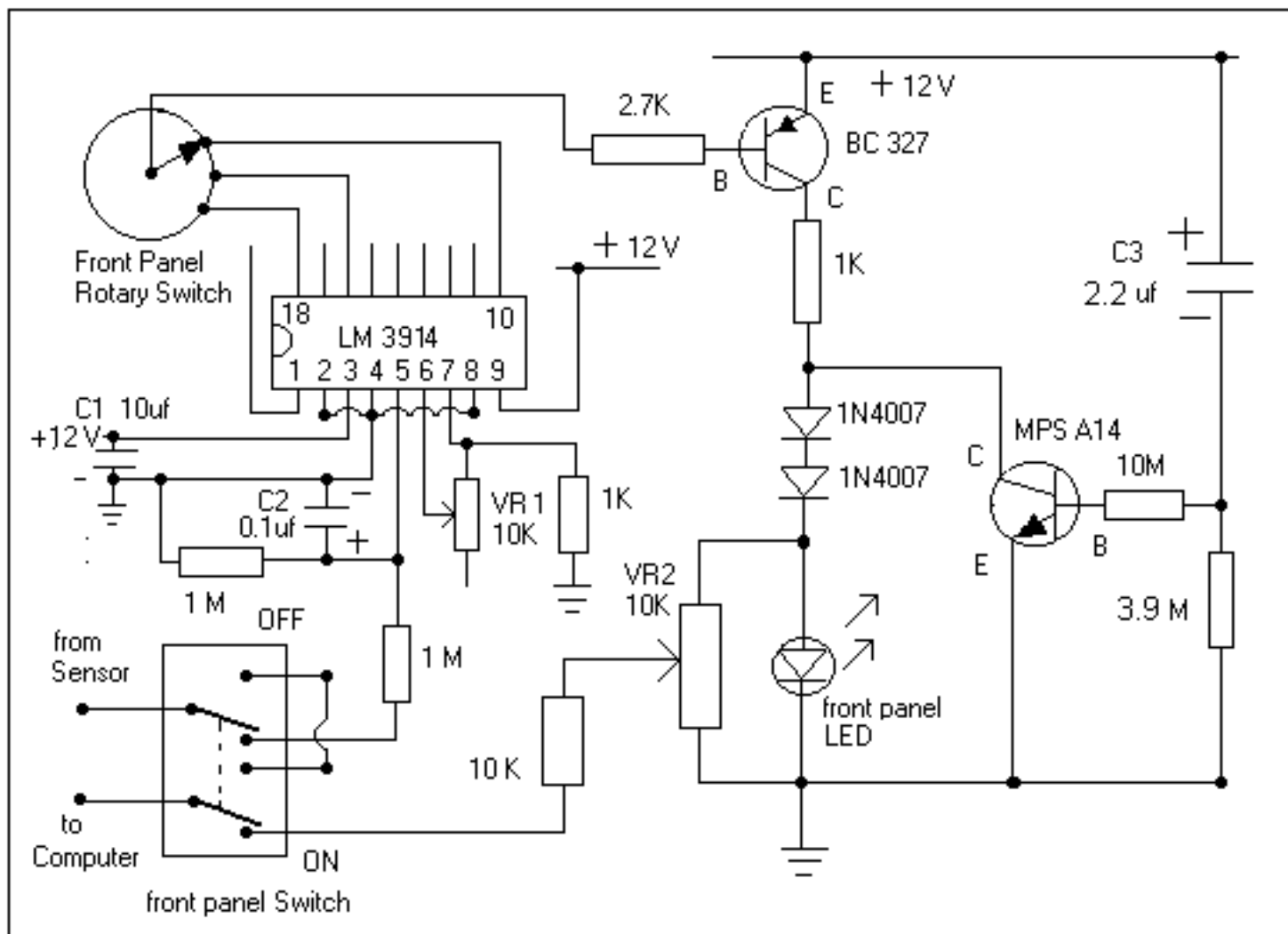

**WARNING This is a static sensitive device.**

Handle it carefully and always use an IC socket to mount it. Don't directly solder the IC into the printed circuit board. Install this component last.

We use this IC to sample the sensor voltage and provide outputs at various thresholds that we can select from. The trim pot R1 sets the sensitivity and we adjust this for 500 mV full scale. Each LED output then is 50 mV apart. We don't actually install LED's on each output, and any unused outputs are left open circuit. The front panel rotary switch selects which ever output we

choose. We only need 2 or 3 to choose from. You can leave out this rotary switch and simply select one of the outputs to connect if you prefer. The front panel on/off switch is a DPDT toggle switch. All the capacitors are electrolytic type of about 16 volt rating. All resistors are 1/4 watt.

The input resistor/capacitor circuit provides filtering of the sensor signal. Because the entire circuit comprises high impedance components, including the sensor and IC input, the input line is susceptible to induced noise. Ignition noise in particular will affect the circuit and cause incorrect operation. If you install the LED Mixture Display as recommended, you will see that until the sensor heats up all the LED's will be dimly lit. This is showing that there is a lot of noise on the line. When the sensor heats up, the signal becomes cleaner and then only the appropriate LED will be lit. We also include a delay circuit so that after start up, the output is held low for a few minutes to simulate a cold sensor. **The sensor must be operating correctly before we send signals to the computer.** The most common problem, if we don't have this delay, is that the output will be high simply from the noise on the signal line. The computer will think the sensor is working, because it is high, and will cut back the fuel to make the signal go low. When this happens we end up with a very lean condition and very poor acceleration.

The front panel switch is very important. It doesn't switch the power to the device. What it does is allow the sensor signal to bypass the device altogether. This is an essential feature. You can switch your vehicle back to it's unmodified state instantly if you suspect that there may be a problem with the device or if the vehicle simply isn't performing as it should. Remember, only you know what you have done to your car and other family members that drive the car may not be able to fix any problems that may arise. Just show them the switch.

The front panel LED is not just to show that the device is operating, but forms a simple voltage regulator for the output signal to the computer. In operation the LED is lit when the output is high. So the correct state for the LED to be in is flashing.

## **BEFORE BEGINNING**

This is a simple test you should perform first. The oxygen sensor earth connection is the exhaust system, which is firmly bolted to the engine. The computer earth is the vehicle body. We have seen that 0.5 volts can make a large difference to the mixture. If the engine is not well and truly earthed to the body then a voltage difference can exist between the two, and 0.5 volts would normally go unnoticed. We can't afford to have that sort of voltage difference when trying to accurately control the mixture.

Start the engine, switch the headlights on high beam, then measure the voltage between the engine and the body. Use an accurate digital volt meter. Any more than 50 mV will mean you have a bad earth connection which will need cleaning and tightening. Modern cars usually have more than one connection so look around. If you have trouble achieving this then use an engine earth connection for your circuit rather than a body connection. What is most important is the signal voltage from the sensor, since we are operating at such low voltages.

## PARTS LIST

IC LM3914 linear LED dot/bar Driver IC
Transistor BC 327 pnp general purpose
Darlington Transistor MPSA14 npn high gain darlington
Diodes 2 x 1N4007 or equivalent
LED 5mm round, any color
Trimpots 2 x 10K linear carbon
Capacitors 3 x Electrolytic 10uF, 0.1uF, 2.2uF
Resistors carbon film 1/4 watt
• 1 x 10M
• 2 x 1M
• 1 x 3.9M
• 1 x 10K
• 1 x 2.7K
• 2 x 1K
Rotary switch single pole
Toggle switch DPDT
Printed circuit board general experimenters board about 2 x 3 inches
Case to fit

## CONSTRUCTION

Read this through completely before beginning.

All the parts needed should be available from your local Radio Shack store.

They will also be able to show you the component orientation and which legs are which etc.

You will require a soldering iron, a 12 volt power supply such as a small power pack and an accurate digital volt meter for this project. No other test equipment will be needed. The 12 volt supply should be well filtered. You want proper DC, not simple rectified AC, which contains too much ripple. Lastly you will require a variable voltage source that can go from 0 to 1 volt to simulate a sensor input. It's simple enough to make this using a resistor and a variable resistor.

The transistors are nothing special, just general purpose devices so it should be OK to substitute where necessary. The darlington transistor (MPSA14) is a special high gain device needed for the delay circuit. Again it is just a general purpose darlington transistor. The printed circuit board can be any general experimenters board approximately 2 x 3 inches. Try to plan ahead and think where you are going to mount the device, either behind the dash or in a small case mounted somewhere. The printed circuit board has to fit and after the components are mounted it will be more difficult to fit in a tight location.

Start with the IC socket, and mount it slightly in from one end. The circuit diagram can give an indication of the general layout of the components. It makes it easier to follow the circuit if the components are in the same position as on the diagram.

You will have to decide for yourself where and how you mount the front panel components, the rotary switch, the on/off switch and the LED indicator.

The IC legs are numbered 1 to 9, left to right across the bottom as seen on the diagram, and 10 to 18, right to left across the top. The notch shows the left end, this is standard for all IC's.

Try to plan the component positions so that you require the least amount of additional wire to make all the connections on the board.

Don't connect the wires to the front panel rotary switch just yet, except for one which connects to pin 10 on the IC. This is the full scale output and will be connected to the rotary switch in the position of FULL RICH, whichever you prefer, fully clockwise or anti-clockwise position. You are going to test you device first on the bench, then decide which outputs you will use for the other switch positions.

Don't install the delay capacitor C3 yet. Don't install the IC yet. Now install all the other components and double check every single solder connection. Check the quality of the joints and check that the circuit complies with the circuit diagram. Before installing the IC you can apply power to the circuit to check for any overheating components. The circuit has been designed such that none of the components will get even slightly warm in operation. If any parts do get excessively hot then there is a problem.

With the IC not installed the output transistor should be off, and the output LED off. The darlington transistor should be off because the capacitor is not installed.

## **ADJUSTING ON THE BENCH**

Disconnect the power before installing the IC.

You can now install the IC, the correct way round or it will be destroyed instantly.

Apply 12 V power to the device.

Set up the test voltage source to 0.5 volts and apply to the input.

Set the switch to the FULL RICH position.

Now adjust the sensitivity control trimpot VR1 so that the output LED is just lit. Leave the trimpot alone and now adjust the test voltage lower then higher to test the adjustment. The LED should come on at 0.5 volts, and go off just below 0.5 volts.

You can measure the voltage on the other output legs and see when each goes on and off. They will be zero volts when on and some very vague voltage when off. The outputs will even sometimes go negative when they are off. We suspect it is something to do with the high impedance outputs rectifying the ripple on the DC supply.

All the outputs should be about 50mV apart in their threshold points.

With the output high, (LED lit) adjust now the output voltage to the computer by adjusting the trimpot VR2. You want to set the output to 1.0 volts.

Adjust the test voltage to below the threshold to turn off the LED. The output voltage should be zero volts.

If all the above happens as it should then your circuit is working correctly. Next install the delay capacitor C3. Set the test voltage above 0.5 volts and turn the power on. It should take about 30 - 120 seconds before the LED comes on. You can adjust the delay by changing the value of the 3.9M timing resistor and/or 2.2uF capacitor. If you find the oxygen sensor heats up quickly then set the timer to a lesser value. Having too long a delay is bad, since the computer could be adding extra fuel to try and make the mixture rich.

The next task is to select which other outputs you want to use, and connect these to the front panel rotary switch. We recommend you use 100mV or 150mV as your lowest output, depending on what other high mileage devices you use.

If you want you can alter the sensitivity to say 400mV full scale to make available settings like 80 or 120mV.

Thoroughly test the device on the bench to be certain it functions as it should.

When you first install the device in you vehicle, use a setting near to 500mV to test the operation of the device. Your performance should be completely normal. Drive like this for a while to prove the system is working reliably before changing to lower settings.



## TESTING IN THE CAR

You can now test the device in the car. Don't install it yet though. Lift the hood and locate the oxygen sensor. Don't cut the sensor wire. Find a convenient place along the wire where you can strip back some of the insulation. You are going to cut it here later, but not yet. Connect this point to the input of your mixture controller and attach the power leads to the battery.

Start the car and allow the sensor to warm up. Remember there is a delay built in so after a few minutes you should see the LED start to flash. Rev the engine and the LED will stay on. When you release the throttle, the LED will go out for a while. A flashing LED is what you want to see. The rate of flashing will be somewhere between 1 and 10 times per second, most likely around 2 per second.

Check that the LED goes out when you switch the front panel switch off.

Now comes the exciting bit, cutting the oxygen sensor wire and inserting the controller. Cut the wire in a convenient place. You are going to use crimp connectors to finish the installation. Use a matching set on the wire you just cut, in case you need to reconnect it back together.

Don't drive the car yet, do this test in the driveway.

With the front panel switch off, start the car and check it runs normally.

Set the front panel rotary switch to the FULL RICH position.(the position connected to the last LED output, 500mV) and switch the device on. The car is now running with a modified oxygen sensor signal although the mixture is still the same. Try the other positions in order and see how it runs.

## INSTALL THE CONTROLLER

Fit the controller to the vehicle and finish hooking up the wiring. **For the 12 volt supply find a connection which is switched with the vehicle ignition.** You don't want to have to turn it off every time you stop.

Return to the FULL RICH setting and road test the car. Drive a few miles at each setting to see how it performs. If you have also installed the **Dash Mounted Mixture Display** you can also see at which level your output LED comes on. It is very reassuring to see the actual sensor output displayed in real time, and to see the Electronic Mixture Controller actually make a

difference to the sensor output.

## **IMPORTANT**

**Only connect the display input to the raw sensor output, not the controller output. The display is independant of the controller, and is not switched off when the controller is switched off. We can at all times see on the display what the sensor is putting out.**

The controller doesn't directly change the sensor output, it fools the computer into cutting back the fuel.

It is up to you to decide which setting you will use for normal driving. If you have not installed any other high mileage device or water injection then you should be conservative in your adjustment. We have installed water injection only and are driving on a setting around 240mV. We believe it is close to ideal at this setting.

## **Mileage Gain**

Since installing this device and the steam injection our mileage has improved approximately 18%. This is in a vehicle that has always been serviced regularly and has driven over 150000 miles.(250000 kilometers)

Good luck with your project and safe motoring.

Coming soon will be sections on alternative fuel, biodiesel, hydrogen, alcohol etc.

[Free Electronic Water Injection Controller Plans.](#)

To the [Vapor Controller.](#)

Back to [better-mileage.com](http://better-mileage.com)

This material is for your personal information only and is not to be reproduced or sold.  
No liability will be accepted for the use or misuse of this information.

The user accepts all risk regarding the use of this information and is responsible for determining the legality of using this product in your particular area, and of any possible

vehicle warranty or insurance consequences.

---

We will soon be adding some more links to related pages such as car insurance quotes, auto insurance brokers, online car insurance quotes from reputable insurance companies. How to save money shopping around for insurance quotes.

[Copyright 2000-2007 All rights reserved](#)