

028269

The IC S 576, constructed in PMOS depletion technology, permits the design of a digital electronic dimmer or light switch. Turning on and off as well as the setting of the required brightness are carried out via a single sensor or via an equivalent extension input, respectively.

**Features**

- Sensor operation – no mechanically moveable switching elements
- Operation is also possible from several extensions by means of sensors or push-buttons
- Can be interchanged with electromechanic wall switches in conventional light installations
- Easy connection to a wireless remote control
- Brightness control with a physiologically approximated linear characteristic
- Very high interference immunity
- The set brightness value remains stored during short line interruptions of < 1 s
- Low power dissipation
- Very few peripheral components
- Clock input provides for automatic dimming (slumber switch)

**Pin configuration**

top view

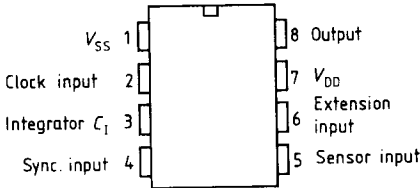

■ Not for new design

**Maximum ratings**

(without external protective circuitry)

		Lower limit B	Upper limit A	
Supply voltage	$V_{DD}$	-20	0.3	V
Input voltage	$V_I$	-20	0.3	V
Ambient temperature during operation	$T_{amb}$	0	80	°C
Junction temperature	$T_j$		125	°C
Storage temperature	$T_{stg}$	-55	125	°C
Thermal resistance (system-air)	$R_{thSA}$		135	K/W

**Characteristics**

$T_{amb} = 25\text{ °C}$ , all voltage ratings are referred to  $V_{SS} = 0\text{ V}$

		Test conditions	Lower limit B	typ	Upper limit A	
Supply voltage	$V_{DD}$		-18	-15	-13	V
Supply current	$I_{DD}$	$V_{DD} = -15\text{ V}$		1.0	1.4	mA
Supply current with missing sync signal	$I_{DD}$	$V_{DD} = -15\text{ V}$			0.85	mA
Input reverse current	$I_I$	$V_I = V_{SS} - 10\text{ V}$		< 0.1	3	μA
Input capacitance	$C_I$	$V_I = 0\text{ V}, f = 1\text{ MHz}$			5	pF

**Sensor input**

H input voltage	$V_{IH}$	with series resistor 10 MΩ from 220 V line	$V_{SS} - 2$			V
L input voltage	$V_{IL}$				$V_{SS} - 8$	V
Input current	$I_{IH}$				35	μA
HL transition time (trigger transition)	$t_{THL}$					
LH transition time	$t_{TLH}$			line sine wave		
Frequency with active signal	$f$	synchronized with 50/60 Hz clock at sync input		50/60		Hz

**Extension input**

H input voltage	$V_{IH}$		$V_{SS} - 2$		V
L input voltage	$V_{IL}$			$V_{SS} - 8$	V
Input current	$I_{IH}$			35	μA

**Characteristics**  
(cont'd)

**Sync input (pin 4)**

	Test conditions	Lower limit B	typ	Upper limit A	
H input voltage	} with series resistor 1.5 MΩ from 220 V line	1/2 V <sub>DD</sub> +2	line sine wave	1/2 V <sub>DD</sub> -2	V
L input voltage					V
Input current					μA
HL transition time (trigger transition)					
LH transition time					
Frequency	f		50/60		Hz

**Clock input (pin 2)**

H input voltage	V <sub>IH</sub>	V <sub>SS</sub> -2		V <sub>S</sub> +0.3	V
L input voltage	V <sub>IL</sub>	V <sub>DD</sub>		V <sub>SS</sub> -8	V
HL transition (trigger transition)	t <sub>THL</sub>			100	μs
LH transition	t <sub>LHL</sub>			100	μs
Clock frequency	f <sub>CLK</sub>	0		500	Hz
Without clock	V <sub>I0</sub>	V <sub>SS</sub>		V <sub>SS</sub> +0.3	V

**Integrator (pin 3)**

External components	C <sub>1</sub>	compare with fig.1}	47		nF
---------------------	----------------	---------------------	----	--	----

**Output**

L output current	I <sub>Q</sub>	V <sub>DD</sub> = -15 V V <sub>QL</sub> = -3 V	25		mA
L pulse width	t <sub>QL</sub>	50 Hz line		40	μs
H output voltage	V <sub>QH</sub>	compare with text	V <sub>SS</sub>		V
HL transition time	t <sub>HLO</sub>			V <sub>SS</sub> +0.5	μs
LH transition time	t <sub>LHO</sub>			20	μs
				20	μs

**Operation of the control inputs**

Input potential during both half waves of the line phase:

Function	Line half wave	Sensor input	Extension input		
operated	positive	L	H		
	negative	0	H		
not operated	positive	H	L	or	0
	negative	0	0		L

H: V<sub>IH</sub>

L: V<sub>IL</sub>

0: any

### **Functional description**

The type series S 576 permits the design of fully electronic dimmers and light switches for light bulbs (resistive loads) which are operated in each case via a single sensor.

In conventional lighting circuit installations it is possible to interchange this component with mechanic wall switches as well as to operate all functions from several switching points (extensions).

The brightness is set by phase control. Its digital logic is synchronized with the line frequency. It is possible to supply the IC via a two-wire-connection as the conduction angle is limited to a maximum of  $152^\circ$  of the half wave.

### **Operation**

#### **1. Dimmers S 576 A, S 576 B, S 576 C (see figure 1)**

The integrated circuit can distinguish the instructions "turning ON/OFF" and "dimming" due to the duration of the control input operation.

#### **Turning ON/OFF**

Short touch (50 to 400 ms) of the sensor area turns the lamp on or off, depending on its preceding state. The switching process is activated at the end of touching.

#### **Setting of the brightness (dimming)**

If the sensor is touched for a longer period ( $> 400$  ms), the conduction angle will be varied continuously. It runs across its control loop in approximately 7 s (e.g. bright-dark-bright) and continues this sequence until the finger is removed from the sensor.

The following process is carried out to enable an easy operation also in the lower brightness range: the phase control angle is controlled such that during the run across the control loops, the lamp brightness varies approximately physiological-linearly with the operating time, and rests for a short period when a minimum brightness is reached.

The conduction angle can be controlled in the half wave range between  $35^\circ$  and  $152^\circ$  by means of the sync input circuitry ( $R_2$ ,  $C_4$ ) specified in the application example.

By increasing the RC time constant it is possible to shift the control range towards smaller conduction angles (effects the minimum brightness).



**2. Light switch S 576 D** (see figure 2)

Upon touching the sensor area (> 50 ms) the lamp is turned on or off alternatively with maximum brightness. The switching process is activated at the start of touching.

Dimming or turning off the light via the clock input is also possible, as in the case with the dimmer.

**Control behavior of the electronic light switch S 576 D** (schematic)

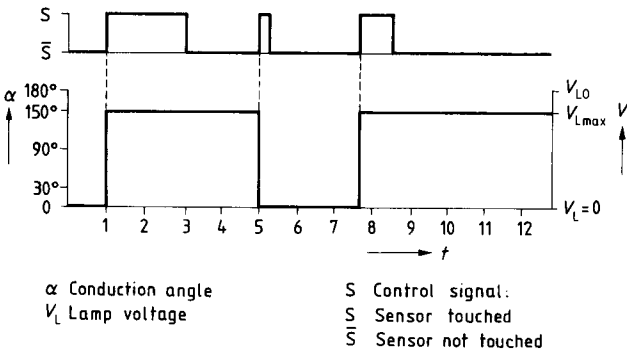

**Figure 2**

**External circuitry** (see figure 3)

The suggested circuit design of S 576 performs the following functions:

- current supply for the circuit ( $R_1$ ,  $C_2$ , D1, D2,  $C_3$ )
- filtered signal for synchronization of the internal time base (PLL circuit) with line frequency ( $R_2$ ,  $C_4$ )
- protection of the user ( $R_8$ ,  $R_9$ )
- sensitivity setting of the sensor ( $R_7$ )
- current limitation in the case of incorrect polarization of the extension ( $R_5$ ,  $R_6$ ).

Both resistors can be omitted if no extension is connected. In this case, pin 6 must be interconnected with  $V_{DD}$  (pin 7).

- D3: reduction of positive voltages which may arise during the triggered state at the gate of some triacs, to values below  $V_{SS} + 0.5$  V (refer to characteristic data). If suitable triacs are used, diode D3 can be omitted. (This feature of the triac depends on the anode current and on the internal resistance between G and A1, and can be measured and specified by the manufacturer).

Application circuit S 576

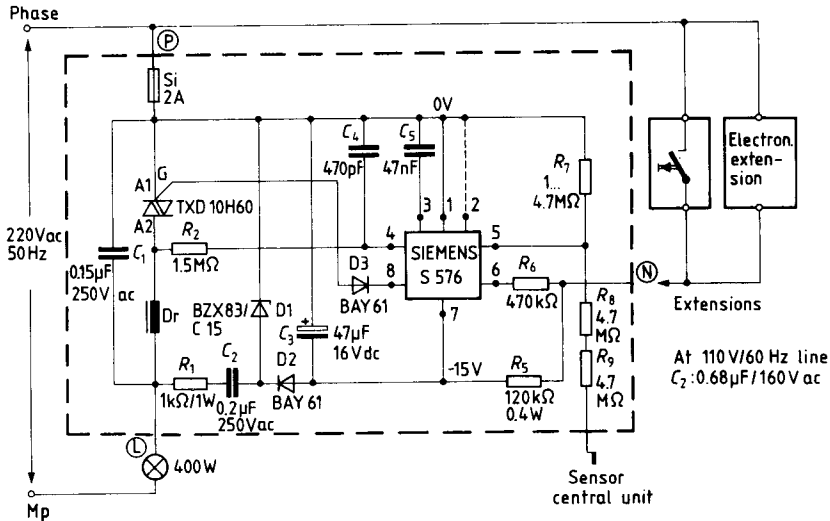

Figure 3

Extensions

All switching and control functions can also be performed from extensions which are connected to an extension input reserved for this purpose. The central unit and the extensions are equivalent. Electronic sensor switches or mechanical pushbutton switches can be connected to the extensions. During operation, H potential must be applied to the extension input for both line half waves.

An electronic circuit suitable for this purpose, is shown in the application example (figure 4). The circuit operates as return delay and takes over the triggering of the switching transistors during the negative line half wave.

- Response time approx. 2 ms
- Return delay time approx. 30 ms
- Protection against incorrect polarization (R<sub>1</sub>, D1, Si)

**Application circuit: electronic extension**

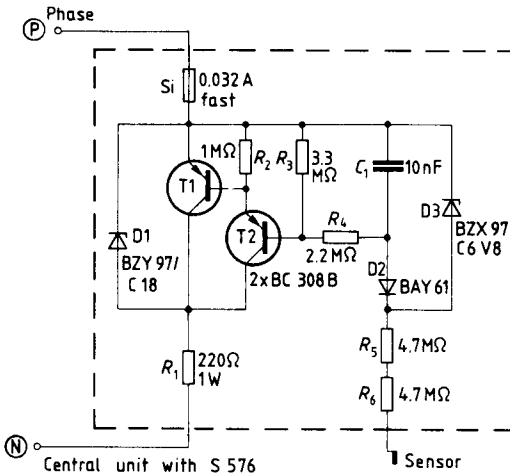

**Figure 4**

**Wireless remote control**

The connection of a wireless remote control to the extension is very easy. All functions of the S 576 can be performed with the aid of a single transmission channel.

**Slumber switch (clock input)**

In the unused state, the clock input is short-circuited to  $V_{SS}$ . A slumber switch can be obtained by applying an externally generated clock to this input. Each H L transition decrements the count of the internal brightness memory by one step. When the minimum brightness is reached, the clock turns the circuit to the OFF-state.



The application example (figure 5) shows an oscillator circuit which can also be connected to the power supply of the electronic dimmer or light switch by means of S 576.

The oscillator is enabled by touching the slumber switch sensor. Touching of the dimmer sensor disables the oscillator and, thereby, interrupts the automatic system.

**Circuitry**

- Oscillator with CMOS gates
- T1 and T2 provide a steep switching transition at the input of gate G3 in order to minimize current consumption ( $< 100 \mu\text{A}$ )
- Setting of the clock frequency and thus setting of the dimming time with the RC network ( $R_5, C_2$ )
- Sensitivity setting of the sensor area ( $R_1$ )

**Application circuit: S 576 with a slumber switch**

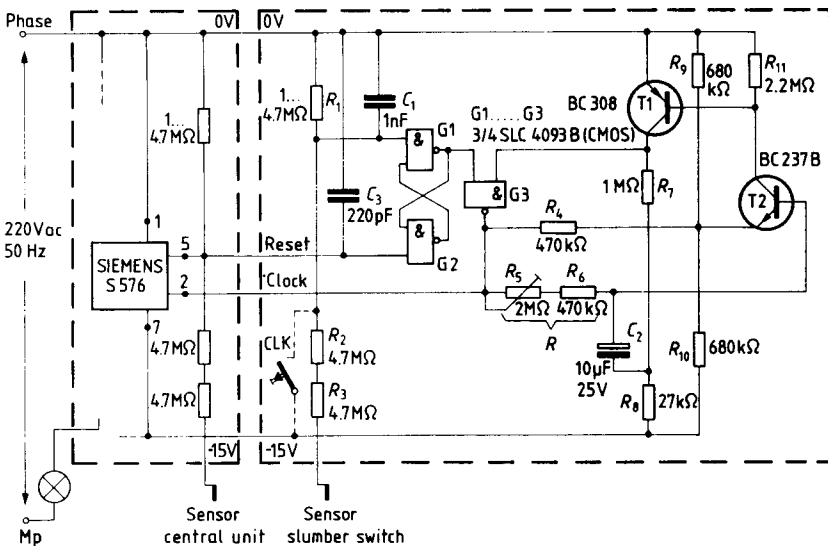

**Figure 5**

### **Interference immunity**

A digitally determined immunity period of approximately 50 ms ensures a high interference immunity against electrical variations on the control inputs, and allows simultaneously an almost delay-free operation.

Due to the special logic of the extension input, even large ground capacitances of the control line will not lead to interference.

In the case of line interruption, the set switching state with the recommended external circuitry remains stored for about 1 s. After line interruptions for longer periods the circuit turns into the OFF-state.

### **General information**

All stated time specifications refer to a line frequency of 50 Hz. In the case of a line frequency of 60 Hz, the periods are shortened accordingly.

This datasheet has been downloaded from:

[www.DatasheetCatalog.com](http://www.DatasheetCatalog.com)

Datasheets for electronic components.