

TT8486A/TT6061A PRODUCT SPECIFICATION

GENERAL DESCRIPTION :

TT8486A/TT6061A IC IS A KIND OF CMOS TECHNOLOGY PERMITTED TO DESIGN 3 STEPS TOUCH-DIMMER. THE DETAILED FUNCTIONS ARE AS FOLLOW :

TT8486A/(TT6061A): OFF → NIGHT → MEDIUM → HIGH → OFF

THE TIME THAT TRIAC TURN ON IS AS FOLLOWING FOR EACH STEP OF ALL FUNCTION

3-STEP MODE	NIGHT	MEDIUM	HIGH
AC=110V/60HZ	5.9 ± 0.4mS	4.0 ± 0.3mS	1.0 ± 0.2mS
AC=220V/50HZ	6.8 ± 0.4mS	4.5 ± 0.3mS	0.9 ± 0.2mS

PIN ASSIGNMENT

PIN NO.	PIN NAME	FUNCTION DESCRIPTION	I/O
1	CK	SYSTEM CLOCK INPUT	I
2	FI	60 OR 50 HZ LINE FREQUENCY	I
3	VDD	POWER INPUT PIN FOR VDD	P
4	TI	TOUCH INPUT	B
5	CI	SENSOR CONTROL INPUT	B
6	NC		
7	VSS	POWER INPUT PIN FOR VSS	P
8	AT	ANGLE-TRIGGER OUTPUT	O

FEATURES :

1. NO MECHANICALLY SWITCH ELEMENTS.
2. HIGH SENSITIVITY AND STABILITY FOR LONG CONNECTING WIRE AND HEAVY LOADING (800pf) ON SENSE-PLATE FOR HUMAN BODY CAPACITY = 50pf
3. VERY SMALL NUMBER OF PERIPHERAL COMPONENTS REQUIRED

OPERATING PARAMETER :

1. OPERATING VOLTAGE : 6.8 V
2. OPERATING CURRENT : 1.0 mA
3. TRIGGER OUTPUT CURRENT (AT PIN) : -30 mA (Vout=6.8V)
4. INPUT LEAKAGE : 0.5 uA
5. INPUT LOW VOLTAGE : VSS + 0.5V
6. INPUT HIGH VOLTAGE : VDD - 0.5V
7. OPERATING TEMPERATURE : 0 80
8. STORAGE TEMPERATURE : -20 120

TT8486A(TT6061A) BLOCK DIAGRAM

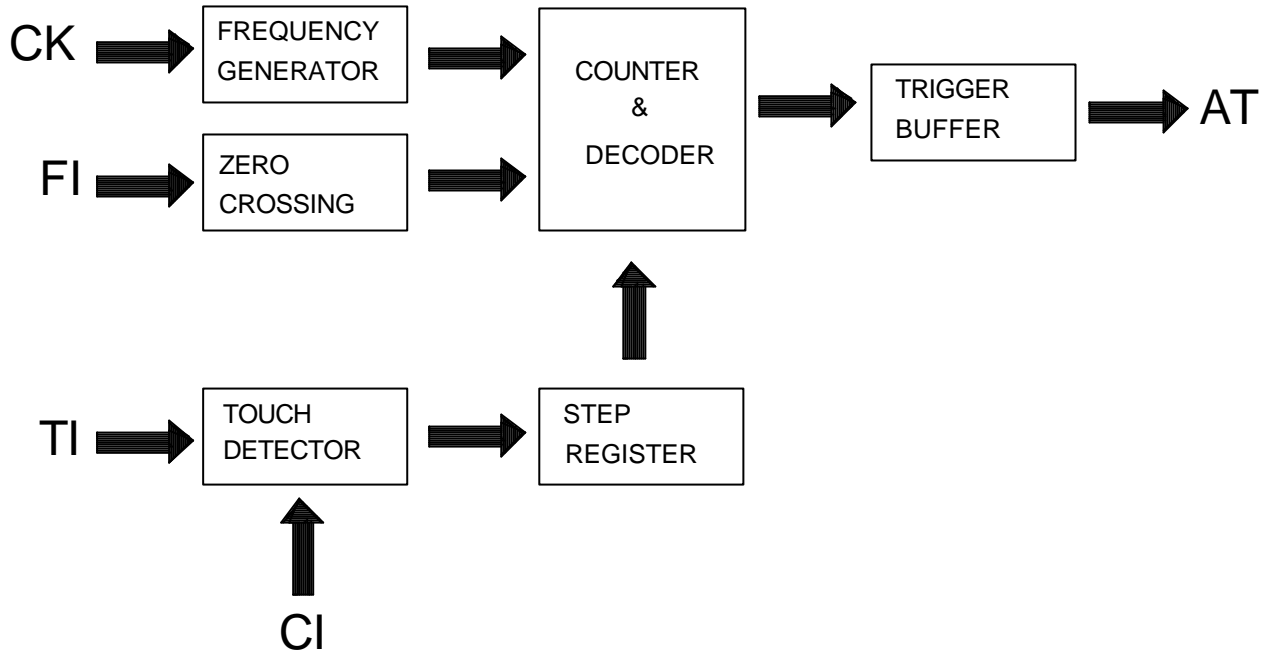

TT8486A/TT6061A RECOMMEND APPLICATION DIAGRAM

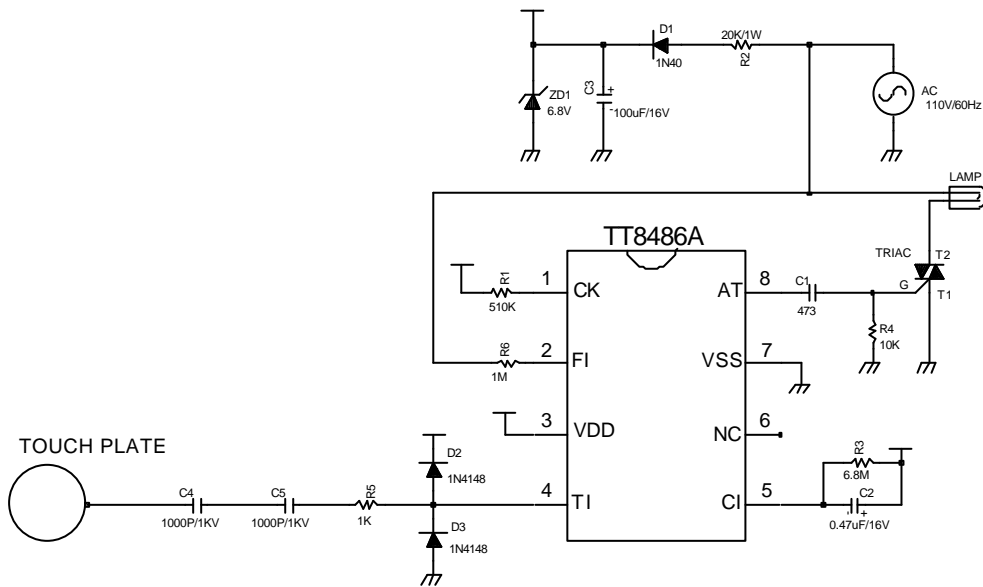

NOTE :FOR 220V/50HZ :
 CHANGE R1 510K TO 620K (FOR 60HZ CHANGE TO 50HZ)
 CHANGE R2 20K/1W TO 40K/2W (FOR 110V CHANGE TO 220V)
 CHANGE R6 1M TO 1.5M (FOR 110V CHANGE TO 220V)

TC8486A PAD'S DIAGRAM

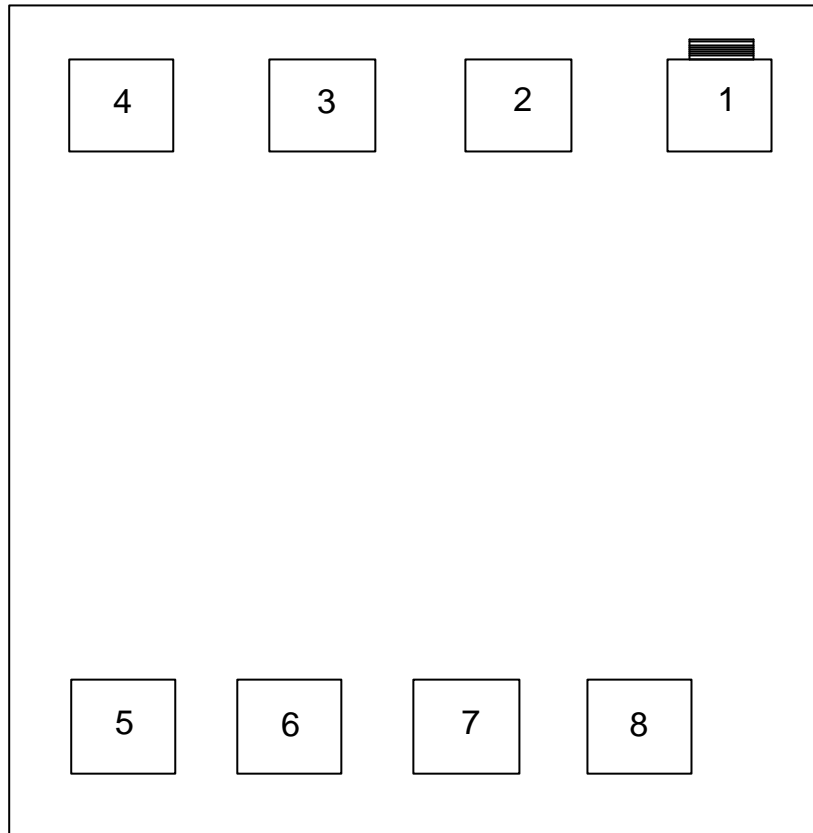

TC8486A PAD'S COORDINATE

PIN NAME	PIN NO.	X	Y
CK	1	199.8	267.7
FI	2	51.3	267.7
VDD	3	-66.6	267.7
TI	4	-199.8	267.7
CI	5	-199.8	-267.7
NC	6	-82.8	-267.7
VSS	7	34.2	-267.7
AT	8	151.2	-267.7

CHIP SIZE : 640 um x 830 um