

Complementary Output Hall Effect Latch

■ Features

- On-chip Hall sensor with two different sensitivity and hysteresis settings for AH276
- 400mA (avg) output sink current
- Built-in protecting diode only for chip reverse power connecting
- -20°C to 85°C operating temperature
- Low profile 4 pin SIP package

■ Applications

- Dual-coil Brush-less DC Motor
- Dual-coil Brush-less DC Fan
- Revolution Counting
- Speed Measurement

■ General Description

AH276 are integrated Hall sensors with output drivers, mainly designed for electronic commutation of brush-less DC Fan. This IC internally includes the regulator, protecting diode, Hall plate, amplifier, comparator, and a pair of complementary open-collector outputs (**DO**, **DOB**).

While the magnetic flux density (**B**) is larger than operate point (**Bop**), **DO** will turn on (low), and meanwhile **DOB** will turn off (high). Each output is latched until **B** is lower than release point (**Brp**), and then **DO**、**DOB** transfer each state.

For DC fan application, sometimes need to test power reverse connection condition. Internal diode only protects chip-side but not for coil-side. If necessary, add one external diode to block the reverse current from coil-side.

■ Ordering Information

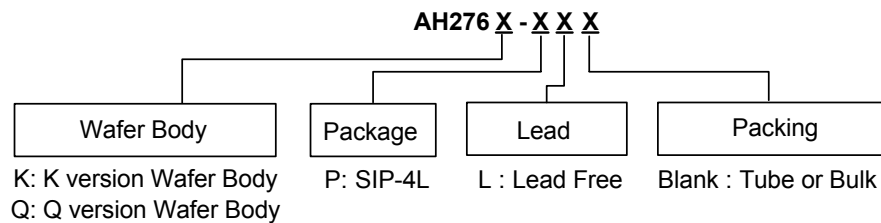

■ Typical Application Circuit

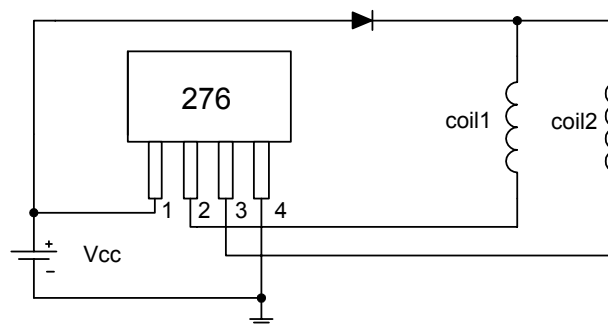

Brush-less DC Fan

Complementary Output Hall Effect Latch

■ Block Diagram

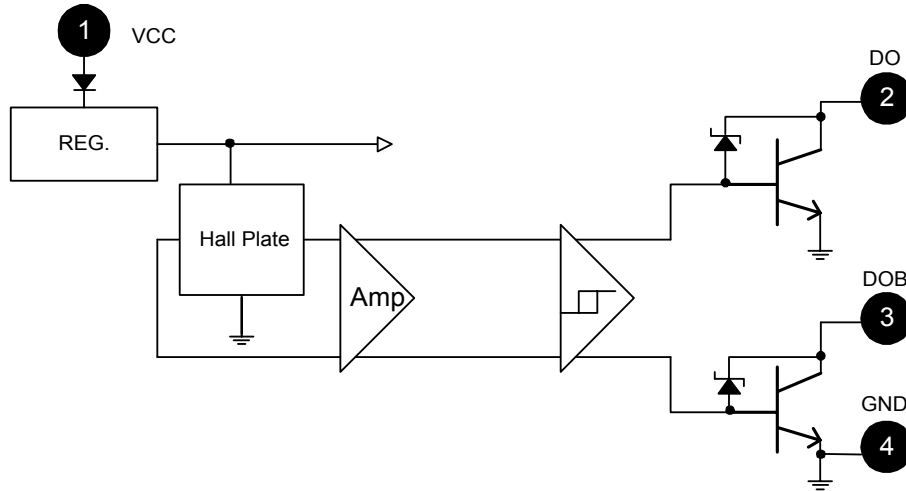

■ Pin Assignment

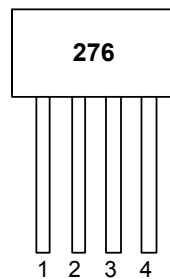

Front View

1 : VCC

2 : DO

3 : DOB

4 : GND

Name	P/I/O	Pin #	Description
Vcc	P	1	Power Supply Input
DO	O	2	Output Pin
DOB	O	3	Output Pin
GND	P	4	Ground

Complementary Output Hall Effect Latch

■ Absolute Maximum Ratings (at Ta=25°C)

Characteristics		Symbol	Values	Unit
Supply voltage		V _{CC}	20	V
Reverse V _{CC} Polarity Voltage		V _{RCC}	-20	V
Magnetic flux density		B	Unlimited	
Output "on" current	Continuous	I _c	0.4	A
	Hold		0.5	
	Peak (Start Up)		0.7	
Operating temperature range		T _a	-20~+85	°C
Storage temperature range		T _s	-65~+150	°C
Package Power Dissipation		PD	550	mW
Maximum Junction Temp		T _j	150	°C

■ Electrical Characteristics (T=+25°C)

Characteristic	Symbol	Conditions	Min	Typ	Max	Units
Low Supply Voltage	V _{ce}	V _{cc} =3.5V, I _L =100mA	-	0.4	-	V
Supply Voltage	V _{cc}	K version	3.5	-	20	V
		Q version	2.5*	-	20	
Output Zener Breakdown	V _z	K version	-	46	-	V
		Q version	-	35	-	
Output Saturation Voltage	V _{ce(sat)}	V _{cc} =14V, I _L =400mA	-	0.7	0.9	V
Output Leakage Current	I _{cex}	V _{ce} =14V, V _{cc} =14V	-	<0.1	10	μA
Supply Current	I _{cc}	V _{cc} =20V, Output Open	-	16	25	mA
Output Rise Time	t _r	V _{cc} =14V, R _L =820Ω, C _L =20pF	-	3.0	10	μs
Output Falling Time	t _f	V _{cc} =14V, R _L =820Ω, C _L =20pF	-	0.3	1.5	μs
Switch Time Differential	Δt	V _{cc} =14V, R _L =820Ω, C _L =20pF	-	3.0	10	μs

*The output of DO/DOB will be switched on/off after supply voltage reaching the 2.5V.

■ Test Circuit

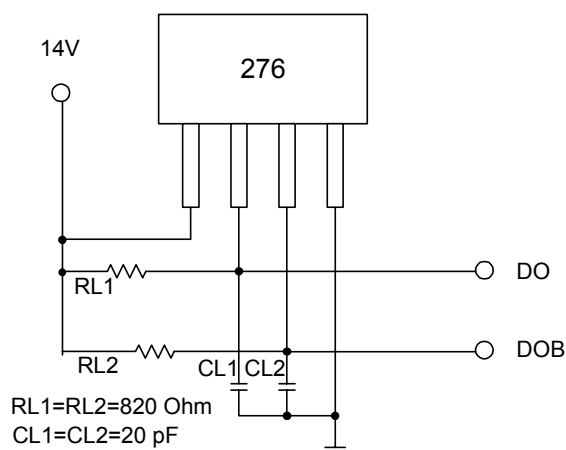

Complementary Output Hall Effect Latch

■ Magnetic Characteristics (Ta=+25°C, Vcc=12V)

K version

(1mT = 10 Gauss)

Characteristic	Symbol	Min.	Typ.	Max.	Unit
Operate Point	Bop	-	-	110	Gauss
Release Point	Brp	-110	-	-	Gauss
Hysteresis	Bhy	-	110	-	Gauss

Q version

Characteristic	Symbol	Min.	Typ.	Max.	Unit
Operate Point	Bop	5	-	70	Gauss
Release Point	Brp	-70	-	-5	Gauss
Hysteresis	Bhy	-	-	-	Gauss

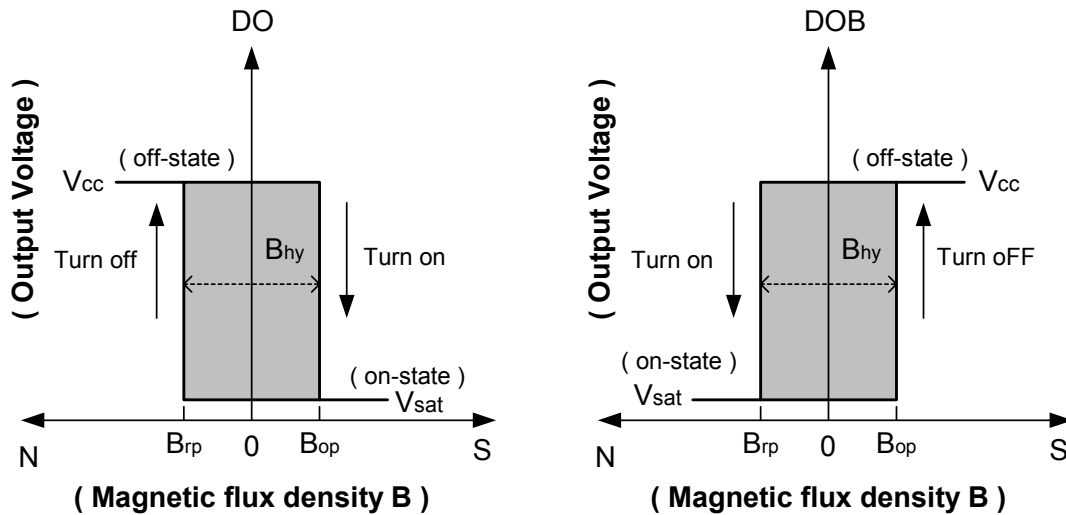

■ Performance Characteristics (SIP-4)

Ta (°C)	25	50	60	70	80	85	90	95	100
Pd (mW)	550	440	396	352	308	286	264	242	220
Ta (°C)	105	110	115	120	125	130	135	140	150
Pd (mW)	198	176	154	132	110	88	66	44	0

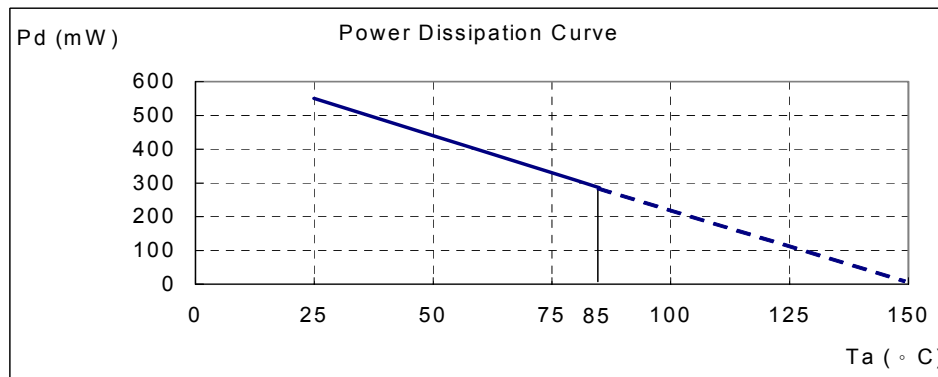

Complementary Output Hall Effect Latch

■ Operating Characteristics

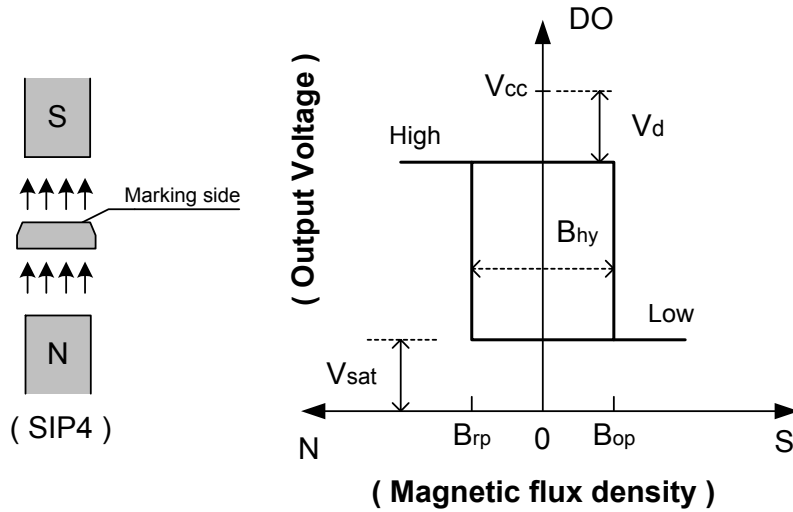

■ Marking Information

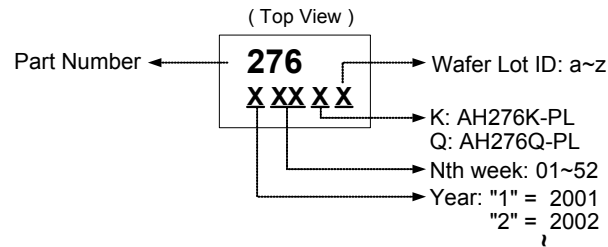

Complementary Output Hall Effect Latch

■ Package Information

Active Area Depth

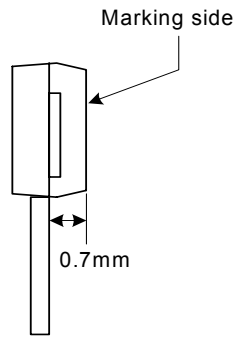

Package Sensor Location

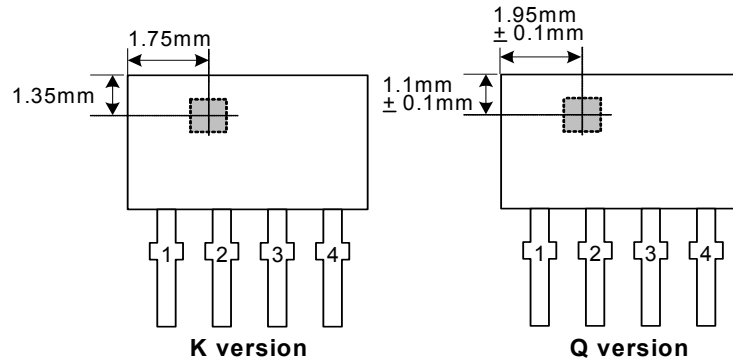

Package Dimension

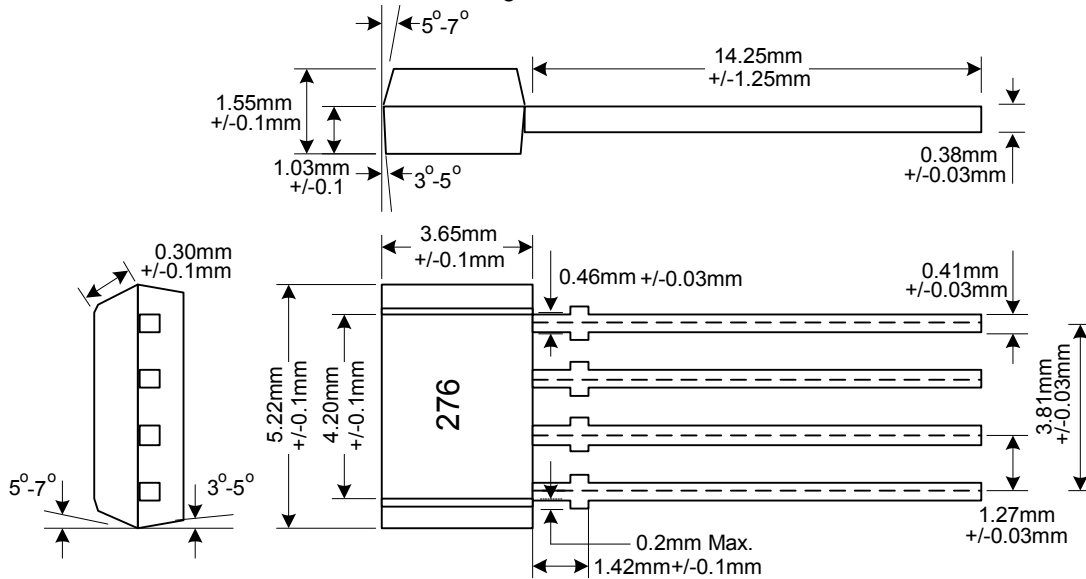

This datasheet has been downloaded from:

www.DatasheetCatalog.com

Datasheets for electronic components.