

TOSHIBA BIPOLAR LINEAR INTEGRATED CIRCUIT SILICON MONOLITHIC

TA7262P, TA7262P(LB), TA7262F

DC MOTOR DRIVER (3 PHASE Bi-DIRECTIONAL)

The TA7262P/P(LB)/F are 3 Phase Bi-Directional supply-voltage-control Motor Driver IC. It's designed especially for energy saving Motor Control System. It contains Power Drivers, CW/CCW control circuit position sensing amplifiers and current regulator for external connected position sensing elements.

FEATURES

- Output Current is Up to 1.5 A (AVE).
- Supply Voltage Control Motor Driver.
- Variable Current Source for Hall Sensor Including.
- Few External Parts Required.
- High Sensitivity of Position Sensing Inputs.

BLOCK DIAGRAM

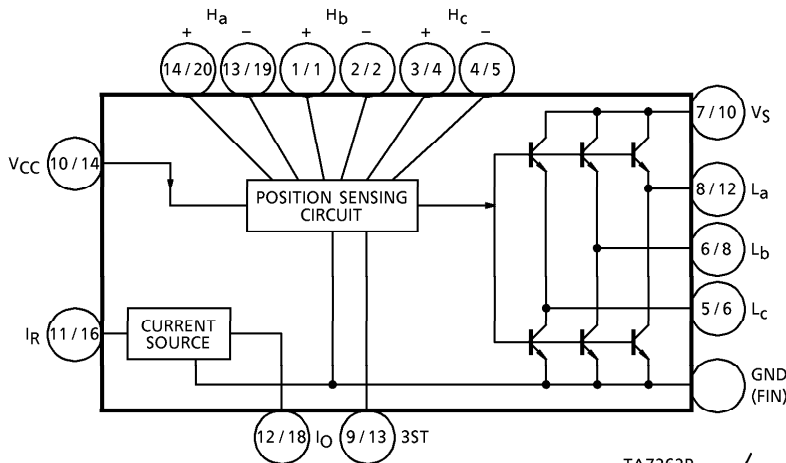

TA7262P
TA7262P (LB) / TA7262F

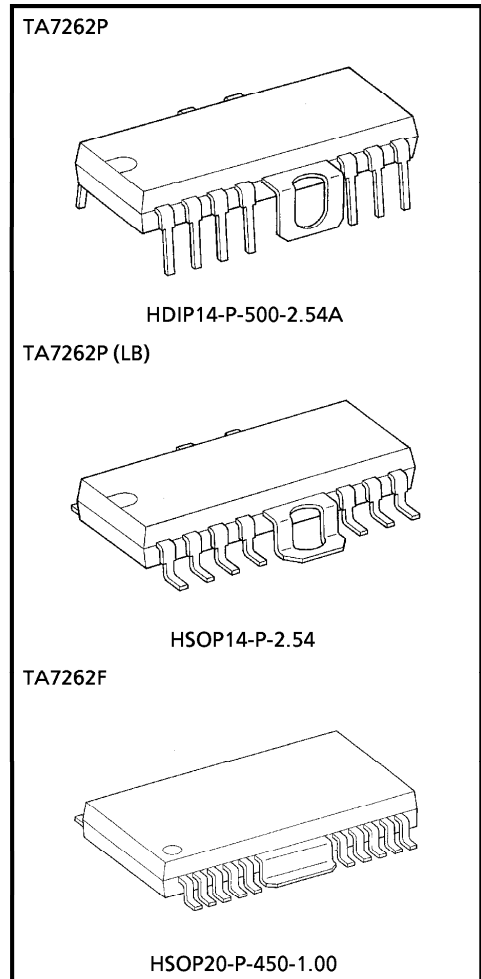

Weight	
HDIP14-P-500-2.54A	: 3.00 g (Typ.)
HSOP14-P-2.54	: 3.00 g (Typ.)
HSOP20-P-450-1.00	: 0.79 g (Typ.)

980910EBA2

- TOSHIBA is continually working to improve the quality and the reliability of its products. Nevertheless, semiconductor devices in general can malfunction or fail due to their inherent electrical sensitivity and vulnerability to physical stress. It is the responsibility of the buyer, when utilizing TOSHIBA products, to observe standards of safety, and to avoid situations in which a malfunction or failure of a TOSHIBA product could cause loss of human life, bodily injury or damage to property. In developing your designs, please ensure that TOSHIBA products are used within specified operating ranges as set forth in the most recent products specifications. Also, please keep in mind the precautions and conditions set forth in the TOSHIBA Semiconductor Reliability Handbook.
- The products described in this document are subject to the foreign exchange and foreign trade laws.
- The information contained herein is presented only as a guide for the applications of our products. No responsibility is assumed by TOSHIBA CORPORATION for any infringements of intellectual property or other rights of the third parties which may result from its use. No license is granted by implication or otherwise under any intellectual property or other rights of TOSHIBA CORPORATION or others.
- The information contained herein is subject to change without notice.

PIN FUNCTION

PIN No.		SYMBOL	FUNCTIONAL DESCRIPTION
P TYPE	F TYPE		
1	1	H _b +	b-phase Hall Amp. positive input terminal
2	2	H _b -	b-phase Hall Amp. negative input terminal
3	4	H _c +	c-phase Hall Amp. positive input terminal
4	5	H _c -	c-phase Hall Amp. negative input terminal
5	6	L _c	c-phase drive output terminal
6	8	L _b	b-phase drive output terminal
7	10	V _S	Supply voltage terminal for motor driver
8	12	L _a	a-phase drive output terminal
9	13	3ST	Forward rotation / Reverse rotation / Stop switch terminal
10	14	V _{CC}	Power supply input terminal for small signal
11	16	I _R	Hall element bias current control terminal
12	18	I _O	Hall element bias negative-side connector terminal
13	19	H _a -	a-phase Hall Amp. negative input terminal
14	20	H _a +	a-phase Hall Amp. positive input terminal
Fin	Fin	GND	—

F Type : Pin ③, ⑦, ⑨, ⑪, ⑮, ⑰ N. C.

FUNCTION

FRS INPUT	POSITION SENSING INPUT			COIL OUTPUT		
	H _a	H _b	H _c	L _a	L _b	L _c
CW	1	0	1	H	L	M
	1	0	0	H	M	L
	1	1	0	M	H	L
	0	1	0	L	H	M
	0	1	1	L	M	H
	0	0	1	M	L	H
CCW	1	0	1	L	H	M
	1	0	0	L	M	H
	1	1	0	M	L	H
	0	1	0	H	L	M
	0	1	1	H	M	L
	0	0	1	M	H	L
STOP	1	0	1	High Impedance		
	1	0	0			
	1	1	0			
	0	1	0			
	0	1	1			
	0	0	1			

MAXIMUM RATINGS (Ta = 25°C)

CHARACTERISTIC	SYMBOL	RATING	UNIT
Supply Voltage (MOTOR)	V _S	25	V
Supply Voltage (CONTROL)	V _{CC}	25	V
Output Current (MOTOR)	I _O	1.5	A
Output Current	I _{CS}	40	mA
Position Sensing Input Voltage	V _H	400	mV _{p-p}
Power Dissipation	TA7262P	P _D (Note)	2.3
	TA7262P (LB)		2.3
	TA7262F		1.0
Operating Temperature	T _{opr}	-30~75	°C
Storage Temperature	T _{stg}	-55~150	°C

(Note) No heat sink

ELECTRICAL CHARACTERISTICS

(Unless otherwise specified, V_{CC} = 9 V, V_S = 12.8 V, 3ST = 5 V, V_H = ±20 mV, R_L = 6 Ω, Ta = 25°C)

CHARACTERISTIC	SYMBOL	TEST CIR-CUIT	TEST CONDITION (TA7262P, TA7262P (LB))	MIN.	TYP.	MAX.	UNIT
Quiescent Current	I _{CC-1}	—	V _{CC} = 9 V, 3 ST GND, V _S open	—	5.7	6.5	mA
	I _{CC-2}	—	V _{CC} = 25 V, 3 ST GND, V _S open	—	8.0	11.0	
	I _{CC-3}	—	Stop (3 ST = V _{CC})	—	—	4	
Saturation Voltage	V _{SAT}	—	I _O = 1 A, (total)	—	—	2.0	V
Saturation Voltage Differential	D-V _{SAT}	—	I _O = 1 A	—	100	180	mV
Cut-off Current	Upper	I _{CC-U}	V _S = 22 V	—	—	50	μA
	Lower	I _{CC-L}	V _S = 22 V	—	—	50	
Position Sensing Input Voltage	Input Sensitivity	V _H	—	—	20	—	mV _{p-p}
	Input Offset	V _{OFST}	—	—	0	5	mV
	Operating DC Level	CMR	—	—	2	—	V _{CC} - 2.5
CW / CCW Control Operating Voltage	CW	V _{FW}	—	1.2	—	7.8	V
	Stop	V _{STP}	—	8.6	V _{CC}	—	
	CCW	V _{RV}	—	—	0	0.4	
Output Current of Current Source	I _{CS-1}	—	I _R open	1.5	2.2	3.0	mA
	I _{CS-2}	—	I _R = 100 Ω	3.0	4.4	5.5	

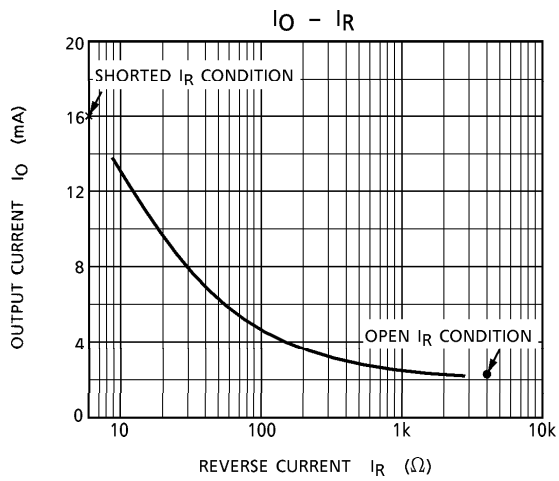
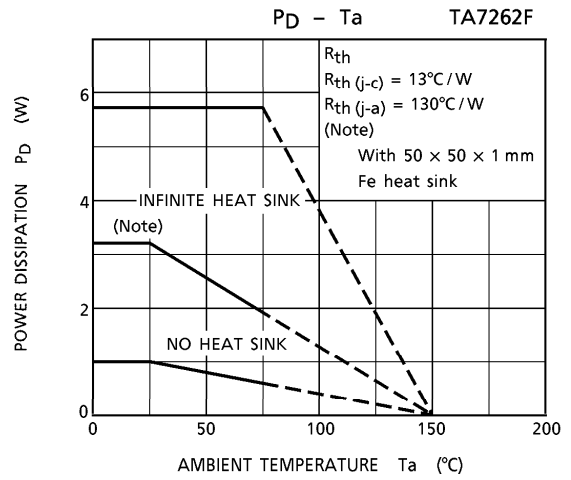
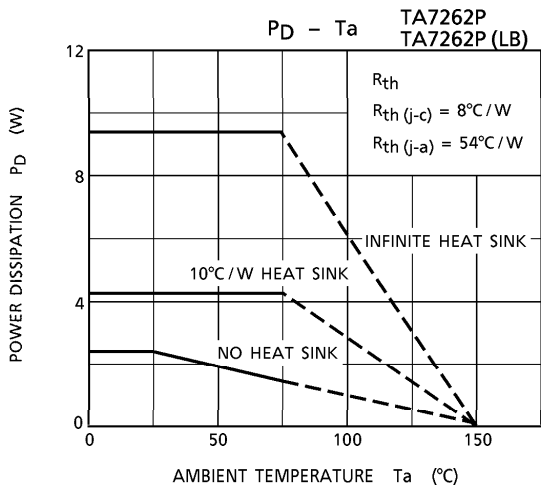

APPLICATION CIRCUIT 1

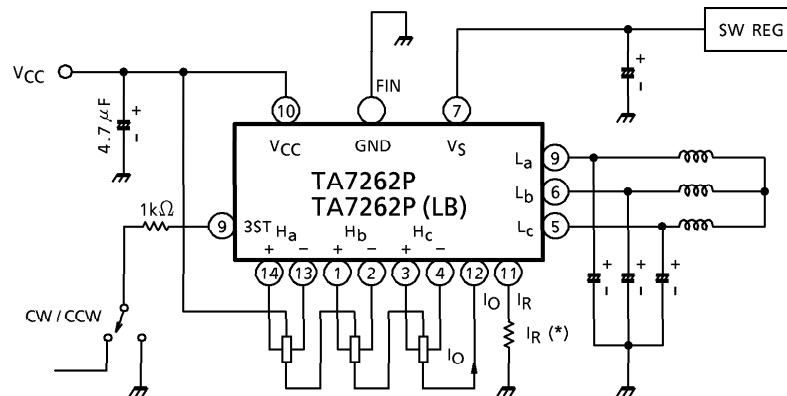

(*) Hall sensor driving current (I_O) can be changed by I_R . Refer to I_R vs I_O characteristics.

APPLICATION CIRCUIT 2

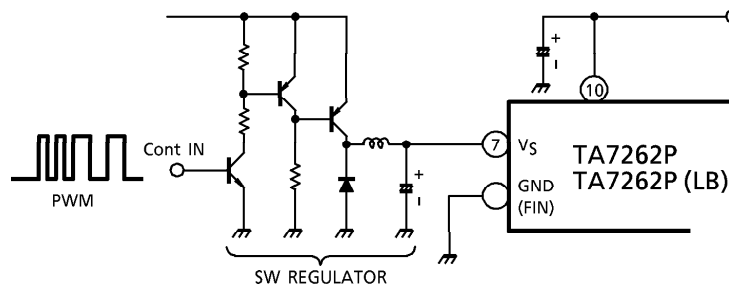

APPLICATION CIRCUIT 3

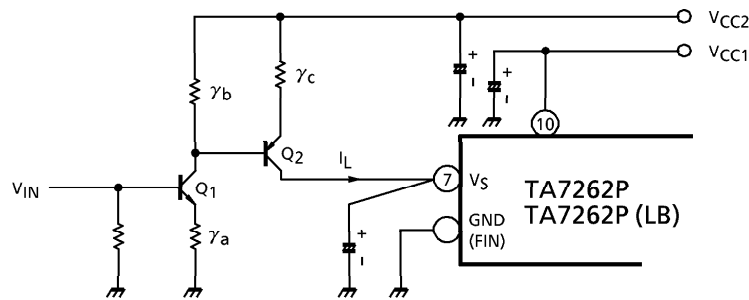

$$I_L \cong \frac{\gamma_b}{\gamma_a \cdot \gamma_c} \cdot V_{IN} - \frac{1}{\gamma_c} \left(\frac{\gamma_b}{\gamma_c} \cdot V_{BE1} + V_{BE2} \right)$$

$$\cong K_1 \cdot V_{IN} + K_2 \quad (K_1, K_2 = \text{Constant})$$

Q_2 works as a Current Regulator for Output Coil. Therefore, Collector to Emitter Voltage of Q_2 is varied in accordance with required coil current.

(Note 1) Utmost care is necessary in the design of the output line, V_S and GND line since IC may be destroyed due to short-circuit between outputs, air contamination fault, or fault by improper grounding.

(Note 2) Don't keep 3ST terminal open.

OUTLINE DRAWING
HDIP14-P-500-2.54A

Unit : mm

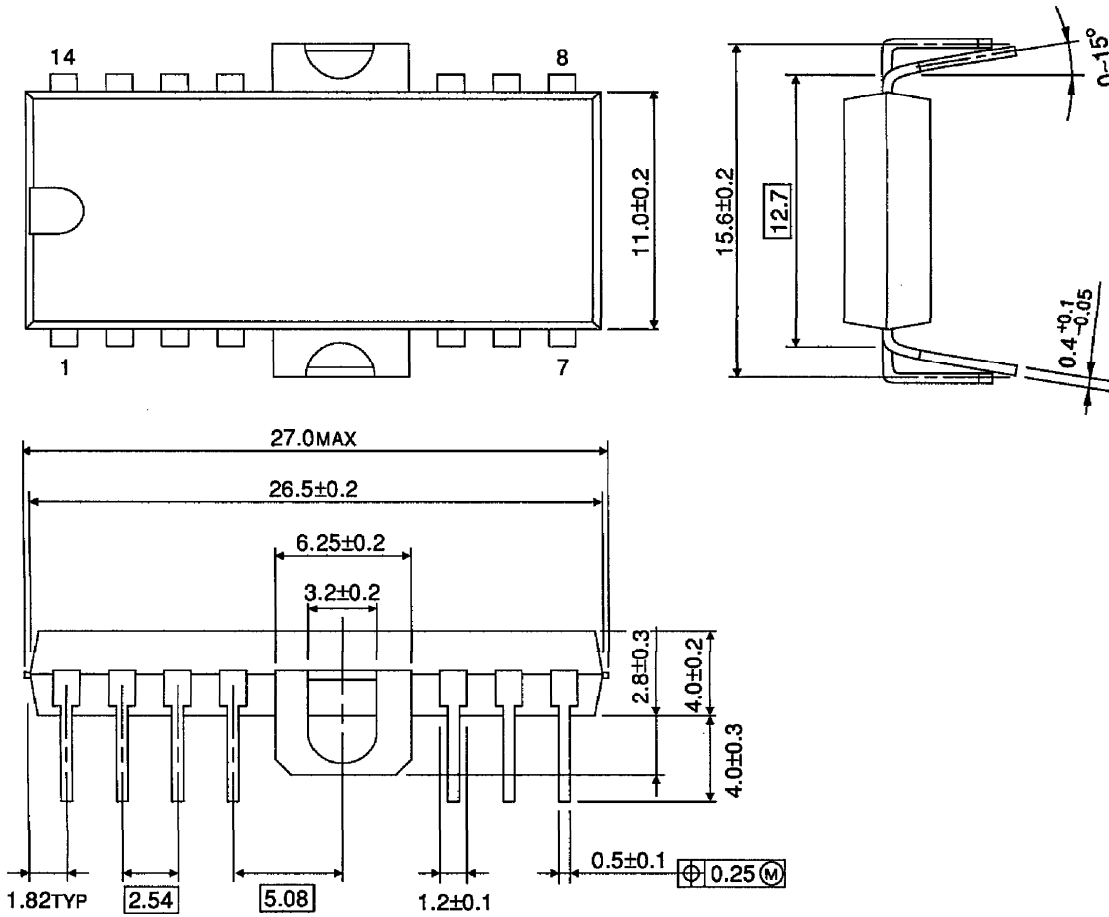

Weight : 3.00 g (Typ.)

OUTLINE DRAWING
HSOP14-P-2.54

Unit : mm

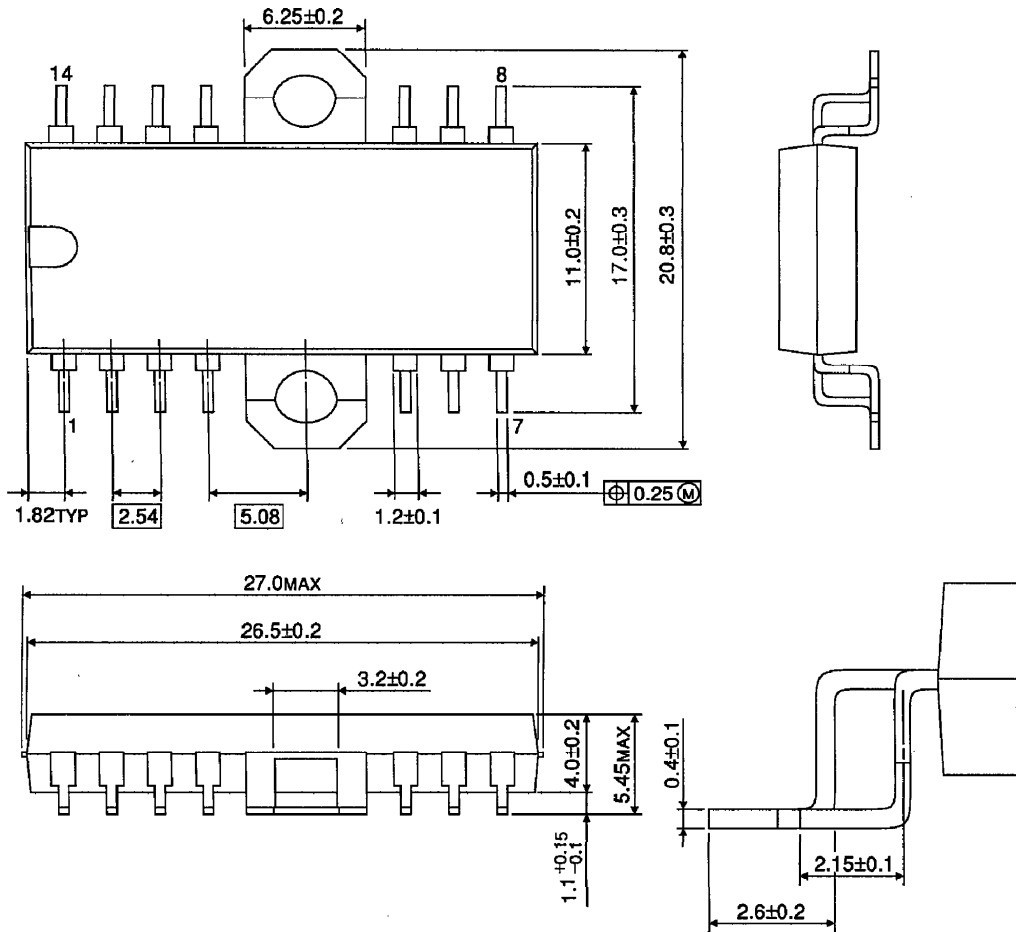

Weight : 3.00 g (Typ.)

OUTLINE DRAWING
HSOP20-P-450-1.00

Unit : mm

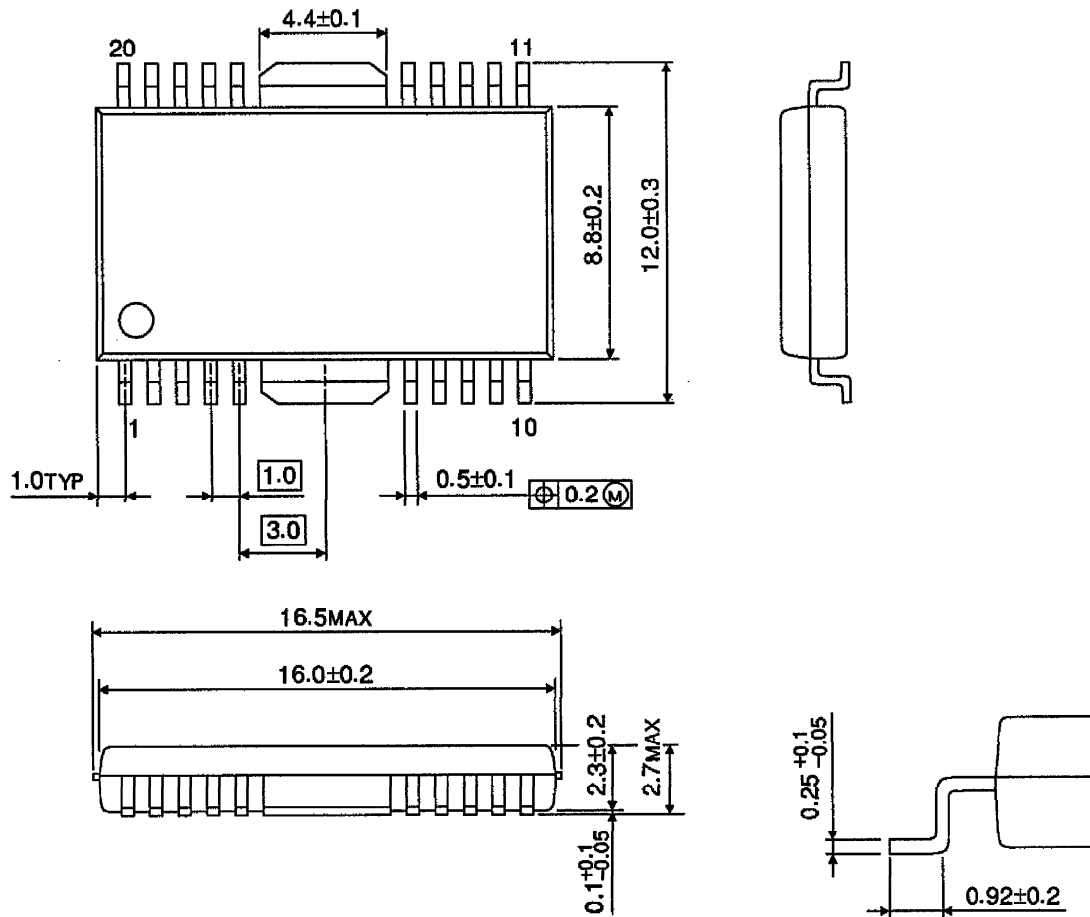

Weight : 0.79 g (Typ.)