

## TOY CAR REMOTE CONTROLLER WITH FIVE FUNCTIONS

### DESCRIPTION

The TX-2B/RX-2B is a pair of CMOS LSIs designed for remote controlled car applications. The TX-2B/RX-2B has five control keys for controlling the motions (i.e. forward, backward, rightward, leftward and the turbo function) of the remote controlled car.

### FEATURES

- \* Wide operating voltage range ( $V_{CC}=1.5\sim 5.0V$ )
- \* Low stand-by current
- \* Auto-power-off function for TX-2B
- \* Few external components are needed

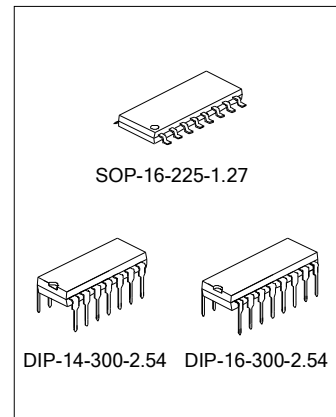

### ORDERING INFORMATION

Device	Package
TX-2B	DIP-14-300-2.54
RX-2B	DIP-16-300-2.54
TX-2BS/RX-2BS	SOP-16-225-1.27

### BLOCK DIAGRAM

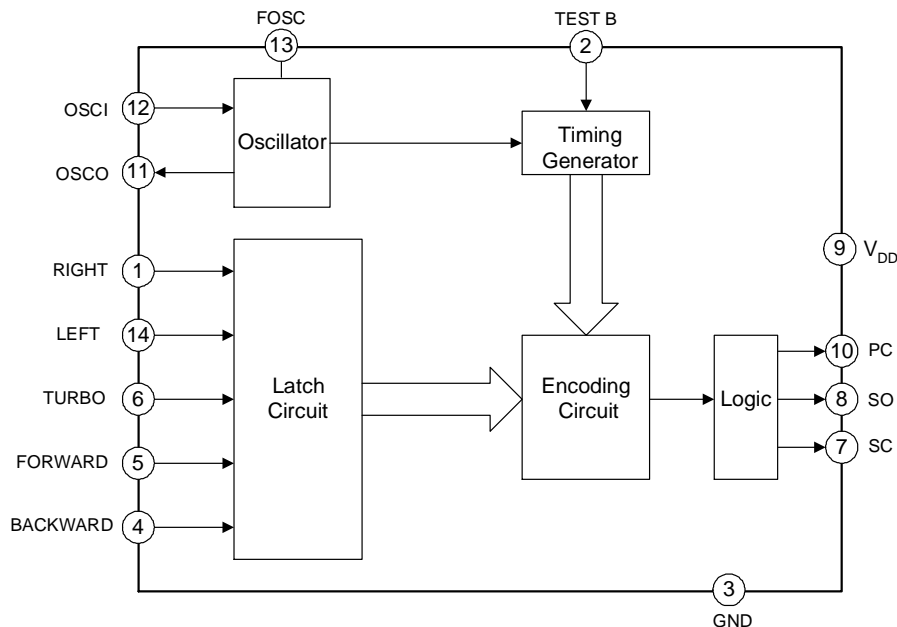

**TRANSMITTER TX-2B Block Diagram**

**BLOCK DIAGRAM** (continued)

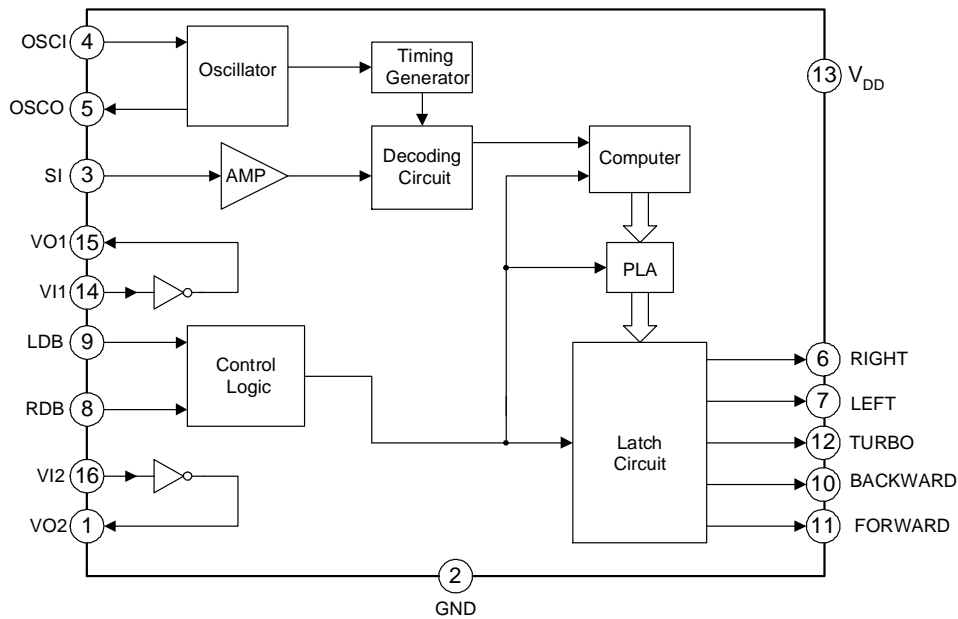

**RECEIVER RX-2B Block Diagram**

**ABSOLUTE MAXIMUM RATINGS**

Characteristics	Symbol	Value	Unit
Supply Voltage	V <sub>DD</sub>	0.3~5.0	V
Input / Output Voltage	V <sub>IN</sub> , V <sub>OUT</sub>	GND-0.3~V <sub>DD</sub> +0.3	V
Operating Temperature	T <sub>OPR</sub>	-10~65	°C
Storage Temperature	T <sub>stg</sub>	-25~125	°C

**ELECTRICAL CHARACTERISTICS**

1. TX-2B (V<sub>DD</sub>=4.0V, F<sub>osc</sub>=128KHz, T<sub>amb</sub>=25°C, unless otherwise specified.)

Characteristics	Symbol	Min.	Typ.	Max.	Unit
Operating Voltage	V <sub>DD</sub>	1.5	4.0	5.0	V
Operating Current	I <sub>DD</sub>	--	--	2.0	mA
Stand-By Current	I <sub>STB</sub>	--	--	10	μA
DC O/P Driving Current	I <sub>drive</sub>	5	--	--	mA
AC O/P Driving Current	I <sub>drive</sub>	5	--	--	mA
AC O/P Frequency	F <sub>audio</sub>	0.5	--	1.0	kHz

**2. RX-2B (V<sub>DD</sub>=4.0V, F<sub>osc</sub>=128KHz, T<sub>amb</sub>=25°C, unless otherwise specified.)**

Characteristics	Symbol	Min.	Typ.	Max.	Unit
Operating Voltage	V <sub>DD</sub>	1.5	4.0	5.0	V
Operating Current	I <sub>DD</sub>	--	--	3.0	mA
O/P Driving Current	I <sub>drive</sub>	1	--	--	mA
O/P Sinking Current	I <sub>sink</sub>	1	--	--	mA
Effect Decoding Frequency Variation	F <sub>tolerance</sub>	-20	--	20	%

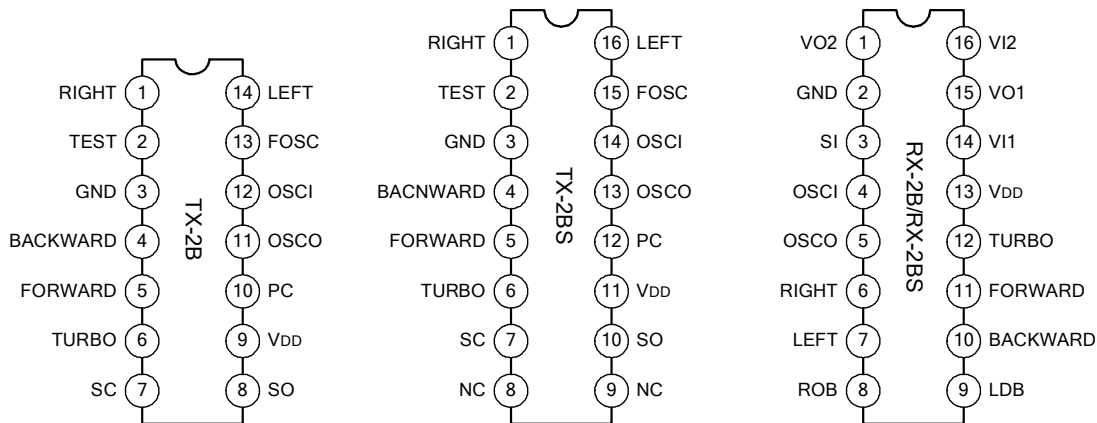
**PIN CONFIGURATION**

**PIN DESCRIPTION**
**1. TX-2B**

Pin No.		Symbol	Description
TX-2B	TX-2BS		
1	1	RIGHT	The rightward function will be selected, if this pin is connected to GND
2	2	TEST	This pin is used for testing mode
3	3	GND	Negative power supply
4	4	BACKWARD	The backward function will be selected, if this pin is connected to GND
5	5	FORWARD	The forward function will be selected, if this pin is connected to GND
6	6	TURBO	The turbo function will be selected if this pin is connected to GND
7	7	SC	Output pin of the encoding signal with carrier frequency
8	10	SO	Output pin of the encoding signal without carrier frequency
9	11	V <sub>DD</sub>	Positive power supply
10	12	PC	Power control output pin
11	13	OSCO	Oscillator output pin
12	14	OSCI	Oscillator input pin
13	15	FOSC	This pin is used for testing mode
14	16	LEFT	The leftward function will be selected, if this pin is connected to GND
	8, 9	NC	Not connect

2. RX-2B

Pin No.	Symbol	Description
1	VO2	Inverter 2 output pin for power amplify
2	GND	Negative power supply
3	SI	Input pin of the encoding signal
4	OSCI	Oscillator input pin
5	OSCO	Oscillator output pin
6	RIGHT	Rightward output pin
7	LEFT	Leftward output pin
8	ROB	Rightward function disable, if this pin is connected to GND
9	LDB	Leftward function disable, if this pin is connected to GND
10	BACKWARD	Backward output pin
11	FORWARD	Forward output pin
12	TURBO	TURBO output pin
13	V <sub>DD</sub>	Positive power supply
14	VI1	Inverter 1 input pin for power amplify
15	VO1	Inverter 1 output pin for power amplify
16	VI2	Inverter 2 input pin for power amplify

FUNCTION DESCRIPTION

Code format

1. ENCODE RULE

(A).Bit Format (W1 is used for function codes,W2 for start codes)

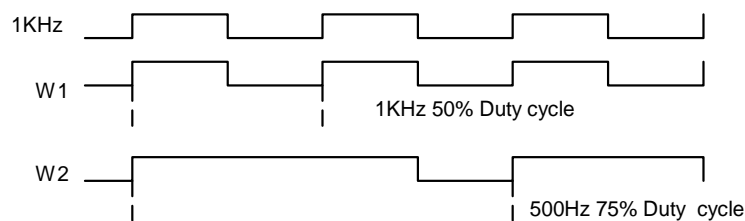

(B).Date Format

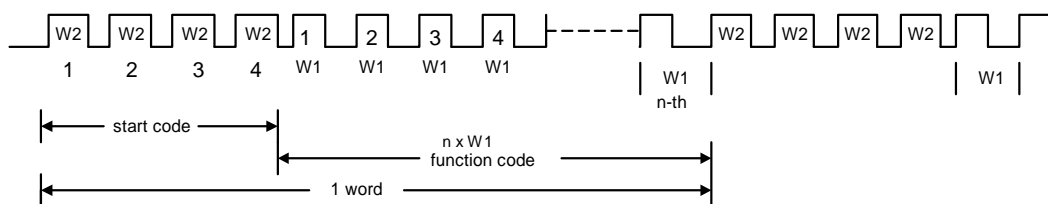
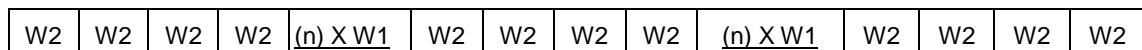

Number Of Function Code (N) W1	Function Key	Decode Result
4		End Code
10	Forward	Forward
16	Forward & Turbo	Forward
22	Turbo	Turbo
28	Turbo & Forward & Left	Forward & Left
34	Turbo & Forward & Right	Forward & Right
40	Backward	Backward
46	Backward & Right	Backward & Right
52	Backward & Left	Backward & Left
58	Left	Left
64	Right	Right

## 2. ENCODE/DECODE TIMING

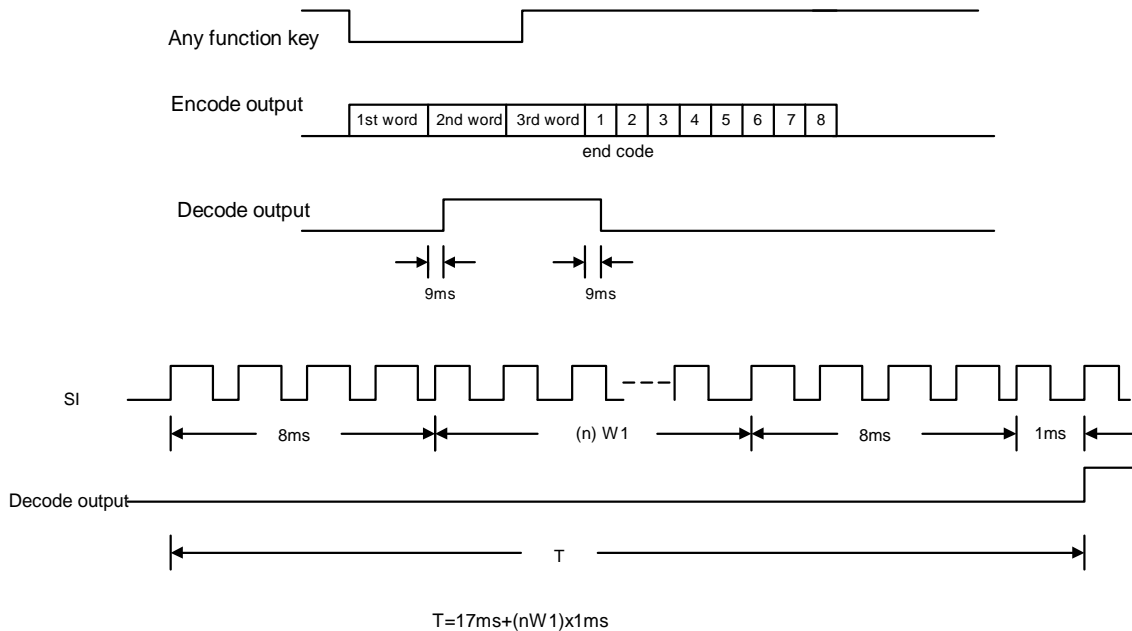

**TESTING CIRCUIT**

(The oscillator frequency of TX-2B, RX-2B is 128KHz, the oscillator resistor is 160KΩ and 250KΩ respectively)

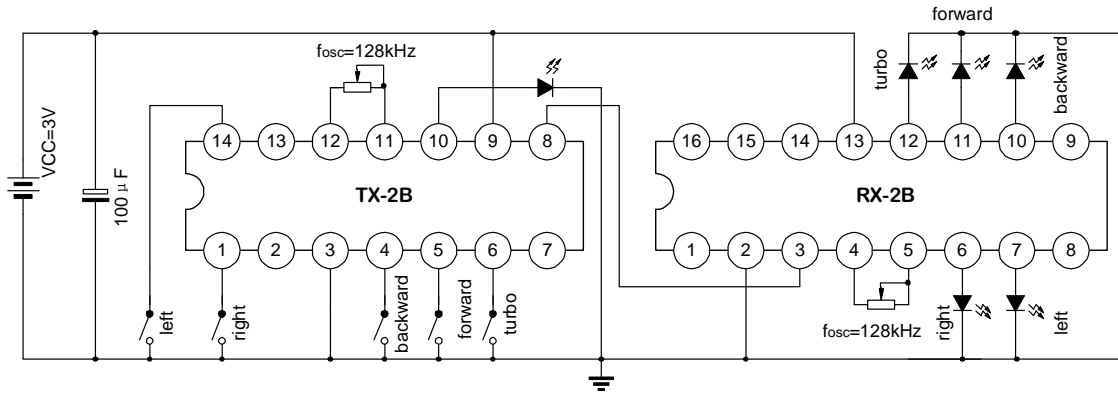

**TYPICAL APPLICATION CIRCUIT**

**TRANSMITTER**

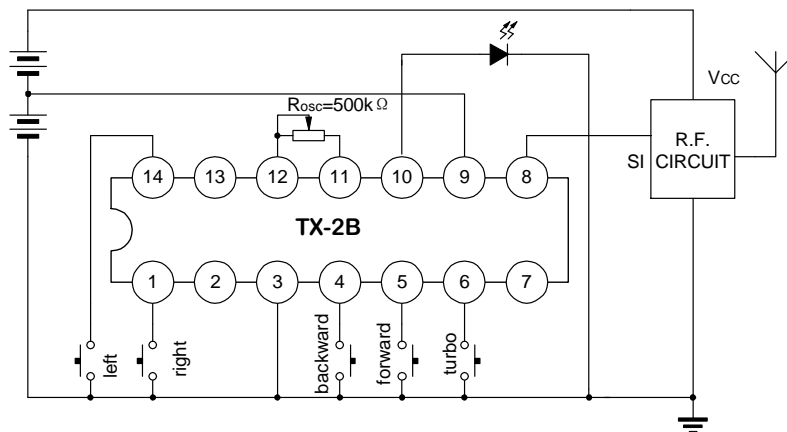

**RECEIVER**

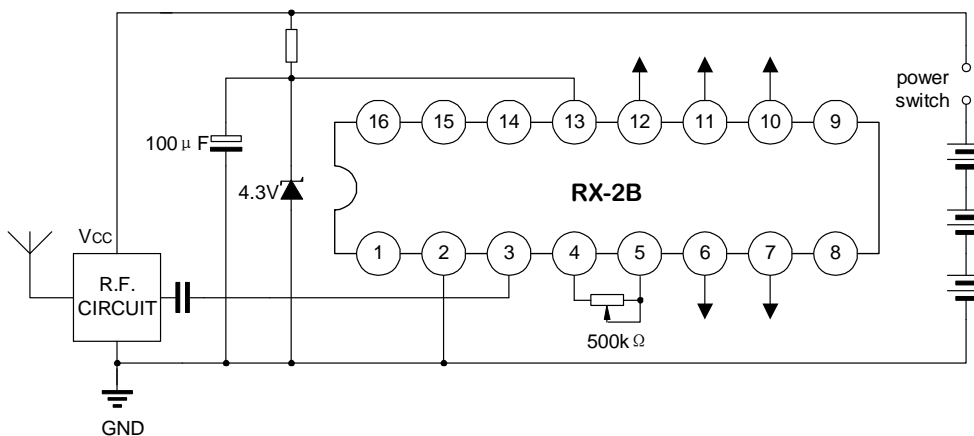

INFRARED APPLICATION CIRCUIT

TRANSMITTER

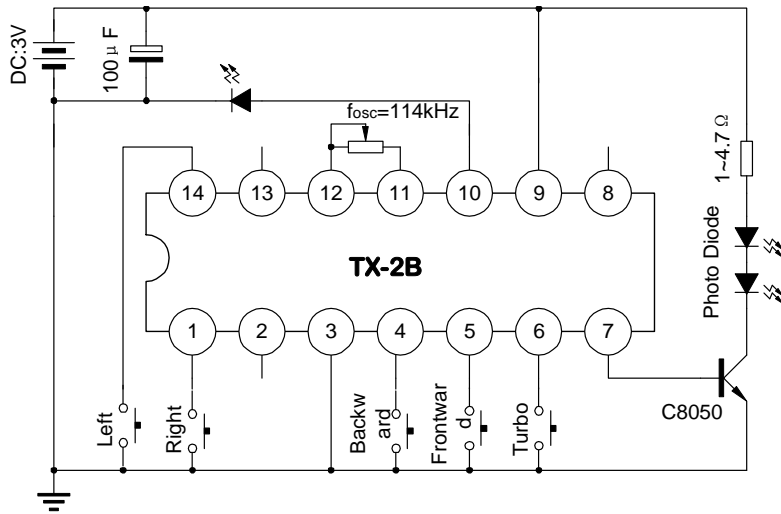

RECEIVER

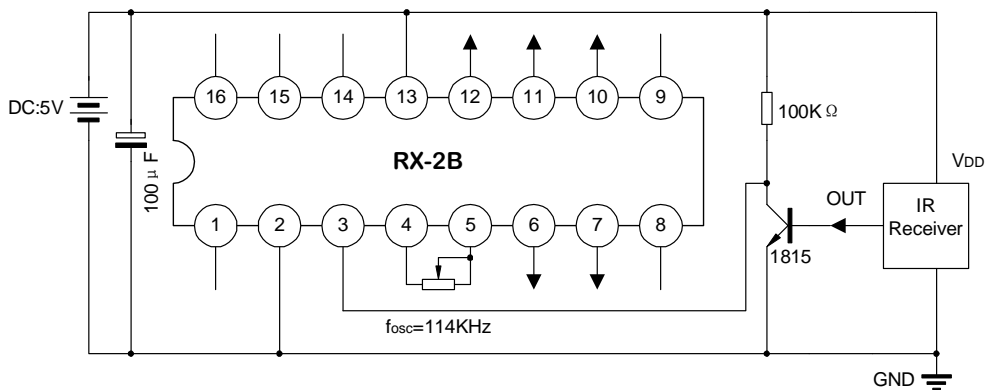

RECOMMENDED APPLICATION CIRCUIT

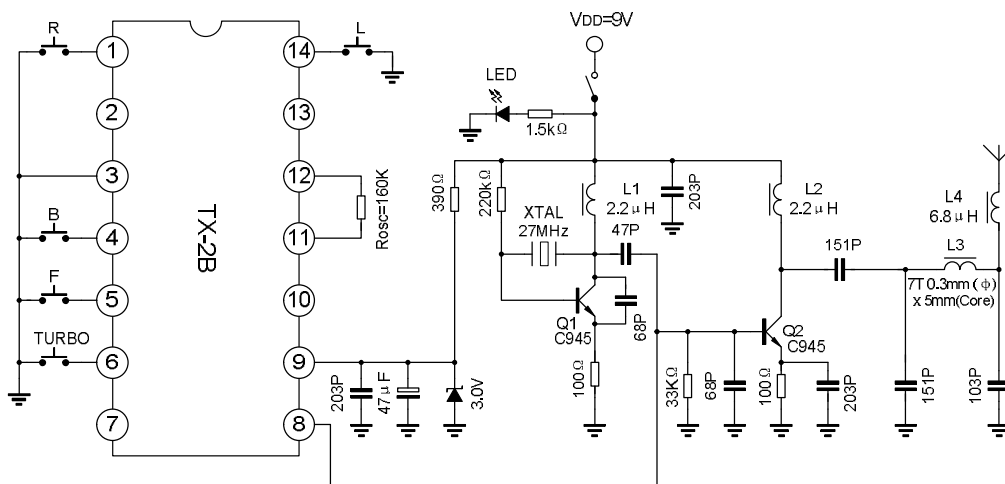

**RECOMMENDED APPLICATION CIRCUIT (continued)**

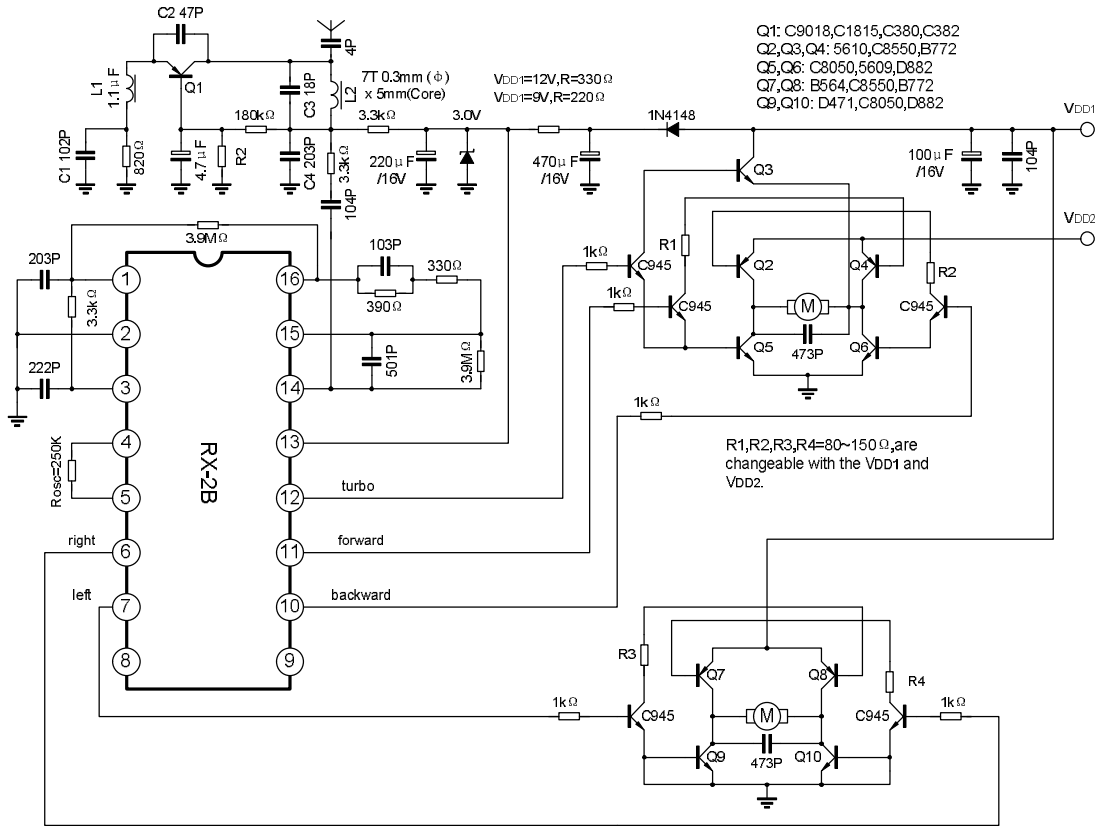

**PACKAGE OUTLINE**

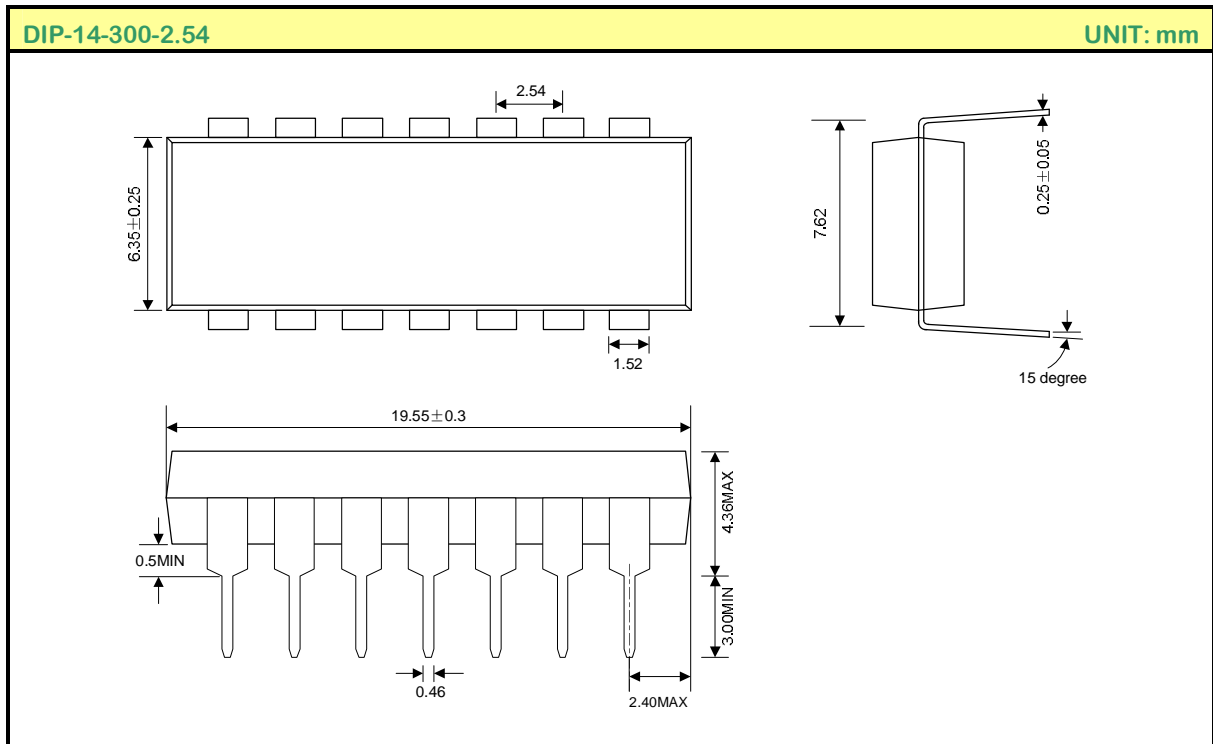



PACKAGE OUTLINE (continued)

DIP-16-300-2.54

UNIT: mm

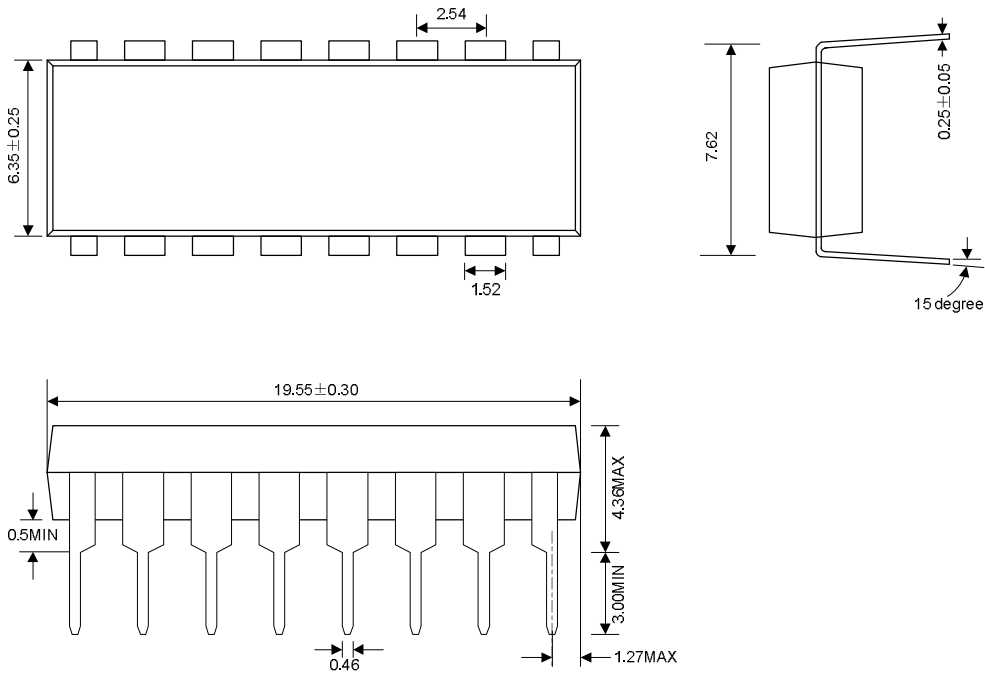

SOP-16-225-1.27

UNIT: mm

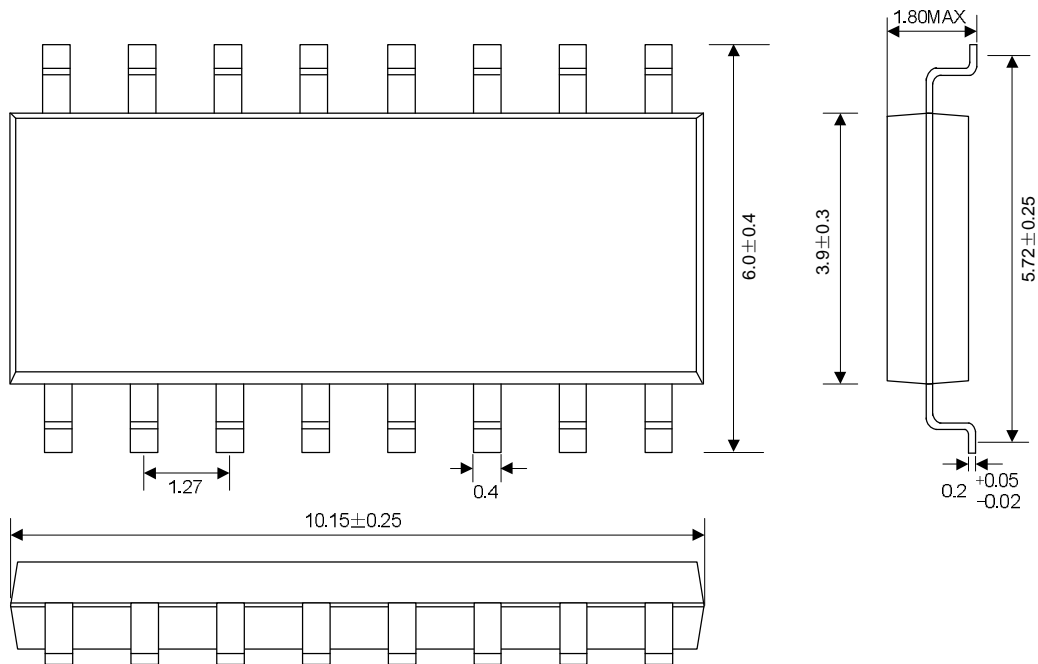



#### **HANDLING MOS DEVICES:**

Electrostatic charges can exist in many things. All of our MOS devices are internally protected against electrostatic discharge but they can be damaged if the following precautions are not taken:

- Persons at a work bench should be earthed via a wrist strap.
- Equipment cases should be earthed.
- All tools used during assembly, including soldering tools and solder baths, must be earthed.
- MOS devices should be packed for dispatch in antistatic/conductive containers.



ATTACHMENT

Revision History

Data	REV	Description	Page
2002.03.11	1.0	Original	
2002.03.21	1.1	Modify the" 2. ENCODE/DECODE TIMING"	
2005.12.19	1.2	Add the package of "SOP-16-225-1.27"	