



Section 15. Motor Control PWM

HIGHLIGHTS

This section of the manual contains the following topics:

| | | |
|-------|--|-------|
| 15.1 | Introduction | 15-2 |
| 15.2 | Control Registers | 15-4 |
| 15.3 | PWM Time Base | 15-16 |
| 15.4 | PWM Duty Cycle Comparison Units | 15-20 |
| 15.5 | Complementary PWM Output Mode | 15-26 |
| 15.6 | Dead Time Control | 15-27 |
| 15.7 | Independent PWM Output Mode | 15-30 |
| 15.8 | PWM Output Override..... | 15-31 |
| 15.9 | PWM Output and Polarity Control..... | 15-33 |
| 15.10 | PWM Fault Pins | 15-34 |
| 15.11 | PWM Update Lockout..... | 15-37 |
| 15.12 | PWM Special Event Trigger | 15-38 |
| 15.13 | Operation in Device Power Saving Modes | 15-38 |
| 15.14 | Special Features for Device Emulation | 15-39 |
| 15.15 | Register Maps..... | 15-40 |
| 15.16 | Related Application Notes..... | 15-42 |
| 15.17 | Revision History | 15-43 |

15.1 Introduction

The motor control PWM (MCPWM) module simplifies the task of generating multiple, synchronized pulse width modulated outputs. In particular, the following power and motion control applications are supported:

- Three-Phase AC Induction Motor
- Switched Reluctance (SR) Motor
- Brushless DC (BLDC) Motor
- Uninterruptable Power Supply (UPS)

The PWM module has the following features:

- Dedicated time base supports $T_{CY}/2$ PWM edge resolution
- Two output pins for each PWM generator
- Complementary or independent operation for each output pin pair
- Hardware dead time generators for complementary mode
- Output pin polarity programmed by device configuration bits
- Multiple output modes:
 - Edge aligned mode
 - Center aligned mode
 - Center aligned mode with double updates
 - Single event mode
- Manual override register for PWM output pins
- Duty cycle updates are configurable to be immediate or synchronized to the PWM
- Hardware fault input pins with programmable function
- Special Event Trigger for synchronizing A/D conversions
- Each output pin associated with the PWM can be individually enabled

15.1.1 MCPWM Module Variants

There are two versions of the MCPWM module depending on the dsPIC30F device that is selected. There is an 8-output module that is typically found on devices that have 64 or more pins. A 6-output MCPWM module is also available and is typically found on smaller devices that have lesser than 64 pins. A given dsPIC30F device may have more than one MCPWM module. Please refer to the specific device data sheet for further details.

Table 15-1: Feature Summary: 6-Output MCPWM vs. 8-Output MCPWM

| Feature | 6-Output MCPWM Module | 8-Output MCPWM Module |
|----------------------|-----------------------|-----------------------|
| I/O Pins | 6 | 8 |
| PWM Generators | 3 | 4 |
| Fault Input Pins | 1 | 2 |
| Dead Time Generators | 1 | 2 |

The 6-output MCPWM module is useful for single or 3-phase power application, while the 8 MCPWM can support 4-phase motor applications. Table 15-1 lists a feature summary for 6- and 8-output MCPWM modules. Both modules can support multiple single phase loads. The 8-output MCPWM also provides increased flexibility in an application because it supports two fault pins and two programmable dead times. These features are discussed in greater detail in subsequent sections.

Figure 15-1 shows a simplified block diagram of the MCPWM module.

Figure 15-1: MCPWM Block Diagram

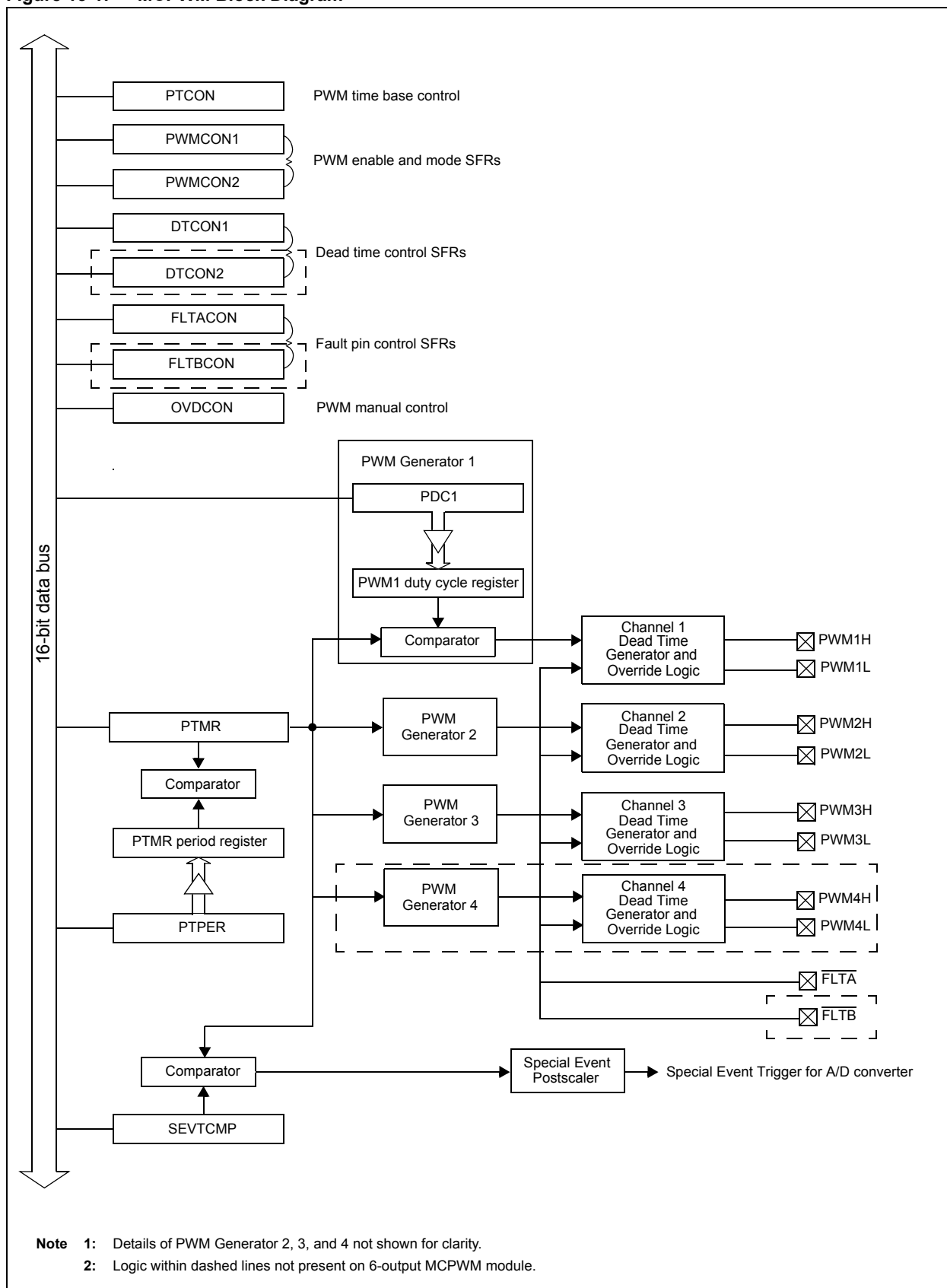

15.2 Control Registers

The registers listed below control the operation of the MCPWM module:

- PTCON: PWM Time Base Control Register
- PTMR: PWM Time Base Register
- PTPER: PWM Time Base Period Register
- SEVTCMP: PWM Special Event Compare Register
- PWMCON1: PWM Control Register 1
- PWMCON2: PWM Control Register 2
- DTCON1: Dead Time Control Register 1
- DTCON2: Dead Time Control Register 2
- FLTACON: Fault A Control Register
- FLTBCON: Fault B Control Register
- PDC1: PWM Duty Cycle Register 1
- PDC2: PWM Duty Cycle Register 2
- PDC3: PWM Duty Cycle Register 3
- PDC4: PWM Duty Cycle Register 4

In addition, there are three device configuration bits associated with the MCPWM module to set up the initial Reset states and polarity of the I/O pins. These configuration bits are located in the FBORPOR device configuration register. Please refer to **Section 24. “Device Configuration”** for further details.

Register 15-1: PTCON: PWM Time Base Control Register

| | | | | | | | |
|--------------------|-----|--------|-----|-----|-----|-----|-------|
| Upper Byte: | | | | | | | |
| R/W-0 | U-0 | R/W-0 | U-0 | U-0 | U-0 | U-0 | U-0 |
| PTEN | — | PTSIDL | — | — | — | — | — |
| bit 15 | | | | | | | bit 8 |

| | | | | | | | |
|--------------------|-------|-------|-------|-------------|-------|------------|-------|
| Lower Byte: | | | | | | | |
| R/W-0 | R/W-0 | R/W-0 | R/W-0 | R/W-0 | R/W-0 | R/W-0 | R/W-0 |
| PTOPS<3:0> | | | | PTCKPS<1:0> | | PTMOD<1:0> | |
| bit 7 | | | | | | | bit 0 |

- bit 15 **PTEN:** PWM Time Base Timer Enable bit
 1 = PWM time base is ON
 0 = PWM time base is OFF

- bit 14 **Unimplemented:** Read as '0'

- bit 13 **PTSIDL:** PWM Time Base Stop in Idle Mode bit
 1 = PWM time base halts in CPU Idle mode
 0 = PWM time base runs in CPU Idle mode

- bit 12-8 **Unimplemented:** Read as '0'

- bit 7-4 **PTOPS<3:0>:** PWM Time Base Output Postscale Select bits
 1111 = 1:16 Postscale
 •
 •
 0001 = 1:2 Postscale
 0000 = 1:1 Postscale

- bit 3-2 **PTCKPS<1:0>:** PWM Time Base Input Clock Prescale Select bits
 11 = PWM time base input clock period is 64 T_{cy} (1:64 prescale)
 10 = PWM time base input clock period is 16 T_{cy} (1:16 prescale)
 01 = PWM time base input clock period is 4 T_{cy} (1:4 prescale)
 00 = PWM time base input clock period is T_{cy} (1:1 prescale)

- bit 1-0 **PTMOD<1:0>:** PWM Time Base Mode Select bits
 11 = PWM time base operates in a continuous up/down mode with interrupts for double PWM updates
 10 = PWM time base operates in a continuous up/down counting mode
 01 = PWM time base operates in single event mode
 00 = PWM time base operates in a free running mode

| | | | |
|-------------------|------------------|------------------------------------|--------------------|
| Legend: | | | |
| R = Readable bit | W = Writable bit | U = Unimplemented bit, read as '0' | |
| -n = Value at POR | '1' = Bit is set | '0' = Bit is cleared | x = Bit is unknown |

dsPIC30F Family Reference Manual

Register 15-2: PTMR: PWM Time Base Register

| | | | | | | | |
|--------------------|-------------|-------|-------|-------|-------|-------|-------|
| Upper Byte: | | | | | | | |
| R-0 | R/W-0 | R/W-0 | R/W-0 | R/W-0 | R/W-0 | R/W-0 | R/W-0 |
| PTDIR | PTMR <14:8> | | | | | | |
| bit 15 | | | | | | | bit 8 |

| | | | | | | | |
|--------------------|-------|-------|-------|-------|-------|-------|-------|
| Lower Byte: | | | | | | | |
| R/W-0 | R/W-0 | R/W-0 | R/W-0 | R/W-0 | R/W-0 | R/W-0 | R/W-0 |
| PTMR <7:0> | | | | | | | |
| bit 7 | | | | | | | bit 0 |

bit 15 **PTDIR:** PWM Time Base Count Direction Status bit (Read Only)

1 = PWM time base is counting down

0 = PWM time base is counting up

bit 14-0 **PTMR <14:0>:** PWM Time Base Register Count Value

Legend:

R = Readable bit

W = Writable bit

U = Unimplemented, read as '0'

-n = Value at POR

'1' = Bit is set

'0' = Bit is cleared

x = Bit is unknown

Register 15-3: PTPER: PWM Time Base Period Register

| | | | | | | | |
|--------------------|--------------|-------|-------|-------|-------|-------|-------|
| Upper Byte: | | | | | | | |
| U-0 | R/W-0 | R/W-0 | R/W-0 | R/W-0 | R/W-0 | R/W-0 | R/W-0 |
| — | PTPER <14:8> | | | | | | |
| bit 15 | | | | | | | bit 8 |

| | | | | | | | |
|--------------------|-------|-------|-------|-------|-------|-------|-------|
| Lower Byte: | | | | | | | |
| R/W-0 | R/W-0 | R/W-0 | R/W-0 | R/W-0 | R/W-0 | R/W-0 | R/W-0 |
| PTPER <7:0> | | | | | | | |
| bit 7 | | | | | | | bit 0 |

bit 15 **Unimplemented:** Read as '0'

bit 14-0 **PTPER<14:0>:** PWM Time Base Period Value bits

Legend:

R = Readable bit

W = Writable bit

U = Unimplemented, read as '0'

-n = Value at POR

'1' = Bit is set

'0' = Bit is cleared

x = Bit is unknown

Register 15-4: SEVTCMP: Special Event Compare Register

| | | | | | | | |
|--------------------|----------------|-------|-------|-------|-------|-------|-------|
| Upper Byte: | | | | | | | |
| R/W-0 | R/W-0 | R/W-0 | R/W-0 | R/W-0 | R/W-0 | R/W-0 | R/W-0 |
| SEVTDIR | SEVTCMP <14:8> | | | | | | |
| bit 15 | | | | | | | bit 8 |

| | | | | | | | |
|--------------------|-------|-------|-------|-------|-------|-------|-------|
| Lower Byte: | | | | | | | |
| R/W-0 | R/W-0 | R/W-0 | R/W-0 | R/W-0 | R/W-0 | R/W-0 | R/W-0 |
| SEVTCMP <7:0> | | | | | | | |
| bit 7 | | | | | | | bit 0 |

bit 15 **SEVTDIR:** Special Event Trigger Time Base Direction bit⁽¹⁾
 1 = A special event trigger will occur when the PWM time base is counting downwards.
 0 = A special event trigger will occur when the PWM time base is counting upwards.

bit 14-0 **SEVTCMP <14:0>:** Special Event Compare Value bit⁽²⁾
Note 1: SEVTDIR is compared with PTDIR (PTMR<15>) to generate the special event trigger.
Note 2: SEVTCMP<14:0> is compared with PTMR<14:0> to generate the special event trigger.

| | | | |
|-------------------|------------------|--------------------------------|--------------------|
| Legend: | | | |
| R = Readable bit | W = Writable bit | U = Unimplemented, read as '0' | |
| -n = Value at POR | '1' = Bit is set | '0' = Bit is cleared | x = Bit is unknown |

Register 15-5: PWMCON1: PWM Control Register 1

| | | | | | | | |
|--------------------|-----|-----|-----|-------|-------|-------|-------|
| Upper Byte: | | | | | | | |
| U-0 | U-0 | U-0 | U-0 | R/W-0 | R/W-0 | R/W-0 | R/W-0 |
| — | — | — | — | PMOD4 | PMOD3 | PMOD2 | PMOD1 |
| bit 15 | | | | | | | bit 8 |

| | | | | | | | |
|--------------------|-------|-------|-------|-------|-------|-------|-------|
| Lower Byte: | | | | | | | |
| R/W-1 | R/W-1 | R/W-1 | R/W-1 | R/W-1 | R/W-1 | R/W-1 | R/W-1 |
| PEN4H | PEN3H | PEN2H | PEN1H | PEN4L | PEN3L | PEN2L | PEN1L |
| bit 7 | | | | | | | bit 0 |

bit 15-12 **Unimplemented:** Read as '0'

bit 11-8 **PMOD4:PMOD1:** PWM I/O Pair Mode bits
 1 = PWM I/O pin pair is in the independent output mode
 0 = PWM I/O pin pair is in the complementary output mode

bit 7-4 **PEN4H-PEN1H:** PWMxH I/O Enable bits⁽¹⁾
 1 = PWMxH pin is enabled for PWM output
 0 = PWMxH pin disabled. I/O pin becomes general purpose I/O

bit 3-0 **PEN4L-PEN1L:** PWMxL I/O Enable bits⁽¹⁾
 1 = PWMxL pin is enabled for PWM output
 0 = PWMxL pin disabled. I/O pin becomes general purpose I/O

Note 1: Reset condition of the PENxH and PENxL bits depend on the value of the PWM/PIN device configuration bit in the FBORPOR Device Configuration Register.

| | | | |
|-------------------|------------------|--------------------------------|--------------------|
| Legend: | | | |
| R = Readable bit | W = Writable bit | U = Unimplemented, read as '0' | |
| -n = Value at POR | '1' = Bit is set | '0' = Bit is cleared | x = Bit is unknown |

dsPIC30F Family Reference Manual

Register 15-6: PWMCON2: PWM Control Register 2

| Upper Byte: | | | | | | | |
|-------------|-----|-----|-----|-------------|-------|-------|-------|
| U-0 | U-0 | U-0 | U-0 | R/W-0 | R/W-0 | R/W-0 | R/W-0 |
| — | — | — | — | SEVOPS<3:0> | | | |
| bit 15 | | | | bit 8 | | | |

| Lower Byte: | | | | | | | |
|-------------|-----|-----|-----|-----|-------|-------|-------|
| U-0 | U-0 | U-0 | U-0 | U-0 | R/W-0 | R/W-0 | R/W-0 |
| — | — | — | — | — | IUE | OSYNC | UDIS |
| bit 7 | | | | | | bit 0 | |

bit 15-12 **Unimplemented:** Read as '0'

bit 11-8 **SEVOPS<3:0>:** PWM Special Event Trigger Output Postscale Select bits

1111 = 1:16 Postscale

•

•

0001 = 1:2 Postscale

0000 = 1:1 Postscale

bit 7-2 **Unimplemented:** Read as '0'

bit 2 **IUE:** Immediate Update Enable bit⁽¹⁾

1 = Updates to the active PDC registers are immediate

0 = Updates to the active PDC registers are synchronized to the PWM time base

bit 1 **OSYNC:** Output Override Synchronization bit

1 = Output overrides via the OVDCON register are synchronized to the PWM time base

0 = Output overrides via the OVDCON register occur on next T_{CY} boundary

bit 0 **UDIS:** PWM Update Disable bit

1 = Updates from duty cycle and period buffer registers are disabled

0 = Updates from duty cycle and period buffer registers are enabled

Note 1: IUE bit is not implemented on the dsPIC30F6010 device.

| Legend: | | | |
|-------------------|------------------|--------------------------------|--------------------|
| R = Readable bit | W = Writable bit | U = Unimplemented, read as '0' | |
| -n = Value at POR | '1' = Bit is set | '0' = Bit is cleared | x = Bit is unknown |

Register 15-7: DTCON1: Dead Time Control Register 1

| | | | | | | | | |
|--------------------|-------|-------|----------|-------|-------|-------|-------|-------|
| Upper Byte: | | | | | | | | |
| R/W-0 | R/W-0 | R/W-0 | R/W-0 | R/W-0 | R/W-0 | R/W-0 | R/W-0 | |
| DTBPS<1:0> | | | DTB<5:0> | | | | | |
| bit 15 | | | | | | | | bit 8 |

| | | | | | | | | |
|--------------------|-------|----------|-------|-------|-------|-------|-------|-------|
| Lower Byte: | | | | | | | | |
| R/W-0 | R/W-0 | R/W-0 | R/W-0 | R/W-0 | R/W-0 | R/W-0 | R/W-0 | |
| DTAPS<1:0> | | DTA<5:0> | | | | | | |
| bit 7 | | | | | | | | bit 0 |

- bit 15-14 **DTBPS<1:0>**: Dead Time Unit B Prescale Select bits
 - 11 = Clock period for Dead Time Unit B is 8 T_{CY}
 - 10 = Clock period for Dead Time Unit B is 4 T_{CY}
 - 01 = Clock period for Dead Time Unit B is 2 T_{CY}
 - 00 = Clock period for Dead Time Unit B is T_{CY}
- bit 13-8 **DTB<5:0>**: Unsigned 6-bit Dead Time Value bits for Dead Time Unit B
- bit 7-6 **DTAPS<1:0>**: Dead Time Unit A Prescale Select bits
 - 11 = Clock period for Dead Time Unit A is 8 T_{CY}
 - 10 = Clock period for Dead Time Unit A is 4 T_{CY}
 - 01 = Clock period for Dead Time Unit A is 2 T_{CY}
 - 00 = Clock period for Dead Time Unit A is T_{CY}
- bit 5-0 **DTA<5:0>**: Unsigned 6-bit Dead Time Value bits for Dead Time Unit A

| | | | |
|-------------------|------------------|--------------------------------|--------------------|
| Legend: | | | |
| R = Readable bit | W = Writable bit | U = Unimplemented, read as '0' | |
| -n = Value at POR | '1' = Bit is set | '0' = Bit is cleared | x = Bit is unknown |

dsPIC30F Family Reference Manual

Register 15-8: DTCON2: Dead Time Control Register 2

| Upper Byte: | | | | | | | |
|-------------|-----|-----|-----|-----|-----|-----|-------|
| U-0 | U-0 | U-0 | U-0 | U-0 | U-0 | U-0 | U-0 |
| — | — | — | — | — | — | — | — |
| bit 15 | | | | | | | bit 8 |

| Lower Byte: | | | | | | | |
|-------------|-------|-------|-------|-------|-------|-------|-------|
| R/W-0 | R/W-0 | R/W-0 | R/W-0 | R/W-0 | R/W-0 | R/W-0 | R/W-0 |
| DTS4A | DTS4I | DTS3A | DTS3I | DTS2A | DTS2I | DTS1A | DTS1I |
| bit 7 | | | | | | | bit 0 |

- bit 15-8 **Unimplemented:** Read as '0'
- bit 7 **DTS4A:** Dead Time Select bit for PWM4 Signal Going Active
1 = Dead time provided from Unit B
0 = Dead time provided from Unit A
- bit 6 **DTS4I:** Dead Time Select bit for PWM4 Signal Going Inactive
1 = Dead time provided from Unit B
0 = Dead time provided from Unit A
- bit 5 **DTS3A:** Dead Time Select bit for PWM3 Signal Going Active
1 = Dead time provided from Unit B
0 = Dead time provided from Unit A
- bit 4 **DTS3I:** Dead Time Select bit for PWM3 Signal Going Inactive
1 = Dead time provided from Unit B
0 = Dead time provided from Unit A
- bit 3 **DTS2A:** Dead Time Select bit for PWM2 Signal Going Active
1 = Dead time provided from Unit B
0 = Dead time provided from Unit A
- bit 2 **DTS2I:** Dead Time Select bit for PWM2 Signal Going Inactive
1 = Dead time provided from Unit B
0 = Dead time provided from Unit A
- bit 1 **DTS1A:** Dead Time Select bit for PWM1 Signal Going Active
1 = Dead time provided from Unit B
0 = Dead time provided from Unit A
- bit 0 **DTS1I:** Dead Time Select bit for PWM1 Signal Going Inactive
1 = Dead time provided from Unit B
0 = Dead time provided from Unit A

| Legend: | | | |
|-------------------|------------------|--------------------------------|--------------------|
| R = Readable bit | W = Writable bit | U = Unimplemented, read as '0' | |
| -n = Value at POR | '1' = Bit is set | '0' = Bit is cleared | x = Bit is unknown |

Register 15-9: FLTACON: Fault A Control Register

| | | | | | | | |
|--------------------|--------|--------|--------|--------|--------|--------|--------|
| Upper Byte: | | | | | | | |
| R/W-0 | R/W-0 | R/W-0 | R/W-0 | R/W-0 | R/W-0 | R/W-0 | R/W-0 |
| FAOV4H | FAOV4L | FAOV3H | FAOV3L | FAOV2H | FAOV2L | FAOV1H | FAOV1L |
| bit 15 | | | | | | bit 8 | |

| | | | | | | | |
|--------------------|-----|-----|-----|-------|-------|-------|-------|
| Lower Byte: | | | | | | | |
| R/W-0 | U-0 | U-0 | U-0 | R/W-0 | R/W-0 | R/W-0 | R/W-0 |
| FLTAM | — | — | — | FAEN4 | FAEN3 | FAEN2 | FAEN1 |
| bit 7 | | | | | | bit 0 | |

- bit 15-8 **FAOV4H-FAOV1L:** Fault Input A PWM Override Value bits
 1 = The PWM output pin is driven ACTIVE on an external fault input event
 0 = The PWM output pin is driven INACTIVE on an external fault input event
- bit 7 **FLTAM:** Fault A Mode bit
 1 = The Fault A input pin functions in the cycle-by-cycle mode
 0 = The Fault A input pin latches all control pins to the programmed states in FLTACON<15:8>
- bit 6-4 **Unimplemented:** Read as '0'
- bit 3 **FAEN4:** Fault Input A Enable bit
 1 = PWM4H/PWM4L pin pair is controlled by Fault Input A
 0 = PWM4H/PWM4L pin pair is not controlled by Fault Input A
- bit 2 **FAEN3:** Fault Input A Enable bit
 1 = PWM3H/PWM3L pin pair is controlled by Fault Input A
 0 = PWM3H/PWM3L pin pair is not controlled by Fault Input A
- bit 1 **FAEN2:** Fault Input A Enable bit
 1 = PWM2H/PWM2L pin pair is controlled by Fault Input A
 0 = PWM2H/PWM2L pin pair is not controlled by Fault Input A
- bit 0 **FAEN1:** Fault Input A Enable bit
 1 = PWM1H/PWM1L pin pair is controlled by Fault Input A
 0 = PWM1H/PWM1L pin pair is not controlled by Fault Input A

| | | | |
|-------------------|------------------|--------------------------------|--------------------|
| Legend: | | | |
| R = Readable bit | W = Writable bit | U = Unimplemented, read as '0' | |
| -n = Value at POR | '1' = Bit is set | '0' = Bit is cleared | x = Bit is unknown |

dsPIC30F Family Reference Manual

Register 15-10: FLTBCON: Fault B Control Register

| | | | | | | | |
|--------------------|--------|--------|--------|--------|--------|--------|--------|
| Upper Byte: | | | | | | | |
| R/W-0 | R/W-0 | R/W-0 | R/W-0 | R/W-0 | R/W-0 | R/W-0 | R/W-0 |
| FBOV4H | FBOV4L | FBOV3H | FBOV3L | FBOV2H | FBOV2L | FBOV1H | FBOV1L |
| bit 15 | | | | | | | bit 8 |

| | | | | | | | |
|--------------------|-----|-----|-----|-------|-------|-------|-------|
| Lower Byte: | | | | | | | |
| R/W-0 | U-0 | U-0 | U-0 | R/W-0 | R/W-0 | R/W-0 | R/W-0 |
| FLTBM | — | — | — | FBEN4 | FBEN3 | FBEN2 | FBEN1 |
| bit 7 | | | | | | | bit 0 |

- bit 15-8 **FBOV4H-FBOV1L:** Fault Input B PWM Override Value bits
 1 = The PWM output pin is driven ACTIVE on an external fault input event
 0 = The PWM output pin is driven INACTIVE on an external fault input event
- bit 7 **FLTBM:** Fault B Mode bit
 1 = The Fault B input pin functions in the cycle-by-cycle mode
 0 = The Fault B input pin latches all control pins to the programmed states in FLTBCON<15:8>
- bit 6-4 **Unimplemented:** Read as '0'
- bit 3 **FAEN4:** Fault Input B Enable bit⁽¹⁾
 1 = PWM4H/PWM4L pin pair is controlled by Fault Input B
 0 = PWM4H/PWM4L pin pair is not controlled by Fault Input B
- bit 2 **FAEN3:** Fault Input B Enable bit⁽¹⁾
 1 = PWM3H/PWM3L pin pair is controlled by Fault Input B
 0 = PWM3H/PWM3L pin pair is not controlled by Fault Input B
- bit 1 **FAEN2:** Fault Input B Enable bit⁽¹⁾
 1 = PWM2H/PWM2L pin pair is controlled by Fault Input B
 0 = PWM2H/PWM2L pin pair is not controlled by Fault Input B
- bit 0 **FAEN1:** Fault Input B Enable bit⁽¹⁾
 1 = PWM1H/PWM1L pin pair is controlled by Fault Input B
 0 = PWM1H/PWM1L pin pair is not controlled by Fault Input B
- Note 1:** Fault pin A has priority over Fault pin B, if enabled.

| | | | |
|-------------------|------------------|--------------------------------|--------------------|
| Legend: | | | |
| R = Readable bit | W = Writable bit | U = Unimplemented, read as '0' | |
| -n = Value at POR | '1' = Bit is set | '0' = Bit is cleared | x = Bit is unknown |

Register 15-11: OVDCON: Override Control Register

| | | | | | | | |
|--------------------|--------|--------|--------|--------|--------|--------|--------|
| Upper Byte: | | | | | | | |
| R/W-1 | R/W-1 | R/W-1 | R/W-1 | R/W-1 | R/W-1 | R/W-1 | R/W-1 |
| POVD4H | POVD4L | POVD3H | POVD3L | POVD2H | POVD2L | POVD1H | POVD1L |
| bit 15 | | | | | | | bit 8 |

| | | | | | | | |
|--------------------|--------|--------|--------|--------|--------|--------|--------|
| Lower Byte: | | | | | | | |
| R/W-0 | R/W-0 | R/W-0 | R/W-0 | R/W-0 | R/W-0 | R/W-0 | R/W-0 |
| POUT4H | POUT4L | POUT3H | POUT3L | POUT2H | POUT2L | POUT1H | POUT1L |
| bit 7 | | | | | | | bit 0 |

- bit 15-8 **POVD4H-POVD1L:** PWM Output Override bits
 1 = Output on PWMxx I/O pin is controlled by the PWM generator
 0 = Output on PWMxx I/O pin is controlled by the value in the corresponding POUTxx bit
- bit 7-0 **POUT4H-POUT1L:** PWM Manual Output bits
 1 = PWMxx I/O pin is driven ACTIVE when the corresponding POVDxx bit is cleared
 0 = PWMxx I/O pin is driven INACTIVE when the corresponding POVDxx bit is cleared

| | | | |
|-------------------|------------------|--------------------------------|--------------------|
| Legend: | | | |
| R = Readable bit | W = Writable bit | U = Unimplemented, read as '0' | |
| -n = Value at POR | '1' = Bit is set | '0' = Bit is cleared | x = Bit is unknown |

Register 15-12: PDC1: PWM Duty Cycle Register 1

| | | | | | | | |
|----------------------------|-------|-------|-------|-------|-------|-------|-------|
| Upper Byte: | | | | | | | |
| R/W-0 | R/W-0 | R/W-0 | R/W-0 | R/W-0 | R/W-0 | R/W-0 | R/W-0 |
| PWM Duty Cycle 1 bits 15-8 | | | | | | | |
| bit 15 | | | | | | | bit 8 |

| | | | | | | | |
|---------------------------|-------|-------|-------|-------|-------|-------|-------|
| Lower Byte: | | | | | | | |
| R/W-0 | R/W-0 | R/W-0 | R/W-0 | R/W-0 | R/W-0 | R/W-0 | R/W-0 |
| PWM Duty Cycle 1 bits 7-0 | | | | | | | |
| bit 7 | | | | | | | bit 0 |

- bit 15-0 **PDC1<15:0>:** PWM Duty Cycle 1 Value bits

| | | | |
|-------------------|------------------|--------------------------------|--------------------|
| Legend: | | | |
| R = Readable bit | W = Writable bit | U = Unimplemented, read as '0' | |
| -n = Value at POR | '1' = Bit is set | '0' = Bit is cleared | x = Bit is unknown |

dsPIC30F Family Reference Manual

Register 15-13: PDC2: PWM Duty Cycle Register 2

| | | | | | | | |
|----------------------------|-------|-------|-------|-------|-------|-------|-------|
| Upper Byte: | | | | | | | |
| R/W-0 | R/W-0 | R/W-0 | R/W-0 | R/W-0 | R/W-0 | R/W-0 | R/W-0 |
| PWM Duty Cycle 2 bits 15-8 | | | | | | | |
| bit 15 | | | | | | | bit 8 |

| | | | | | | | |
|---------------------------|-------|-------|-------|-------|-------|-------|-------|
| Lower Byte: | | | | | | | |
| R/W-0 | R/W-0 | R/W-0 | R/W-0 | R/W-0 | R/W-0 | R/W-0 | R/W-0 |
| PWM Duty Cycle 2 bits 7-0 | | | | | | | |
| bit 7 | | | | | | | bit 0 |

bit 15-0 **PDC2<15:0>**: PWM Duty Cycle 2 Value bits

| | | | |
|-------------------|------------------|--------------------------------|--------------------|
| Legend: | | | |
| R = Readable bit | W = Writable bit | U = Unimplemented, read as '0' | |
| -n = Value at POR | '1' = Bit is set | '0' = Bit is cleared | x = Bit is unknown |

Register 15-14: PDC3: PWM Duty Cycle Register 3

| | | | | | | | |
|----------------------------|-------|-------|-------|-------|-------|-------|-------|
| Upper Byte: | | | | | | | |
| R/W-0 | R/W-0 | R/W-0 | R/W-0 | R/W-0 | R/W-0 | R/W-0 | R/W-0 |
| PWM Duty Cycle 3 bits 15-8 | | | | | | | |
| bit 15 | | | | | | | bit 8 |

| | | | | | | | |
|---------------------------|-------|-------|-------|-------|-------|-------|-------|
| Lower Byte: | | | | | | | |
| R/W-0 | R/W-0 | R/W-0 | R/W-0 | R/W-0 | R/W-0 | R/W-0 | R/W-0 |
| PWM Duty Cycle 3 bits 7-0 | | | | | | | |
| bit 7 | | | | | | | bit 0 |

bit 15-0 **PDC3<15:0>**: PWM Duty Cycle 3 Value bits

| | | | |
|-------------------|------------------|--------------------------------|--------------------|
| Legend: | | | |
| R = Readable bit | W = Writable bit | U = Unimplemented, read as '0' | |
| -n = Value at POR | '1' = Bit is set | '0' = Bit is cleared | x = Bit is unknown |

Register 15-15: PDC4: PWM Duty Cycle Register 4

| | | | | | | | |
|----------------------------|-------|-------|-------|-------|-------|-------|-------|
| Upper Byte: | | | | | | | |
| R/W-0 | R/W-0 | R/W-0 | R/W-0 | R/W-0 | R/W-0 | R/W-0 | R/W-0 |
| PWM Duty Cycle 4 bits 15-8 | | | | | | | |
| bit 15 | | | | | | | bit 8 |

| | | | | | | | |
|---------------------------|-------|-------|-------|-------|-------|-------|-------|
| Lower Byte: | | | | | | | |
| R/W-0 | R/W-0 | R/W-0 | R/W-0 | R/W-0 | R/W-0 | R/W-0 | R/W-0 |
| PWM Duty Cycle 4 bits 7-0 | | | | | | | |
| bit 7 | | | | | | | bit 0 |

bit 15-0 **PDC4<15:0>**: PWM Duty Cycle 4 Value bits

| | | | |
|-------------------|------------------|--------------------------------|--------------------|
| Legend: | | | |
| R = Readable bit | W = Writable bit | U = Unimplemented, read as '0' | |
| -n = Value at POR | '1' = Bit is set | '0' = Bit is cleared | x = Bit is unknown |

Register 15-16: FBORPOR: BOR AND POR Device Configuration Register

| | | | | | | | |
|--------------------|-----|-----|-----|-----|-----|-----|--------|
| Upper Byte: | | | | | | | |
| U-0 | U-0 | U-0 | U-0 | U-0 | U-0 | U-0 | U-0 |
| — | — | — | — | — | — | — | — |
| bit 23 | | | | | | | bit 16 |

| | | | | | | | | |
|---------------------|-----|-----|-----|-----|--------|------|-------|--|
| Middle Byte: | | | | | | | | |
| U-0 | U-0 | U-0 | U-0 | U-0 | R/P | R/P | R/P | |
| — | — | — | — | — | PWMPIN | HPOL | LPOL | |
| bit 15 | | | | | | | bit 8 | |

| | | | | | | | | |
|--------------------|-----|-----------|-----|-----|-----|-----|------------|--|
| Lower Byte: | | | | | | | | |
| R/P | U-0 | R/P | R/P | U-0 | U-0 | R/P | R/P | |
| BOREN | — | BORV<1:0> | | | — | — | FPWRT<1:0> | |
| bit 7 | | | | | | | bit 0 | |

bit 10 **PWMPIN**: MPWM Drivers Initialization bit
 1 = Pin state at reset controlled by I/O Port (PWMCON1<7:0> = 0x00)
 0 = Pin state at reset controlled by module (PWMCON1<7:0> = 0xFF)

bit 9 **HPOL**: MCPWM High Side Drivers (PWMxH) Polarity bit
 1 = Output signal on PWMxH pins has active high polarity
 0 = Output signal on PWMxH pins has active low polarity

bit 8 **LPOL**: MCPWM Low Side Drivers (PWMxL) Polarity bit
 1 = Output signal on PWMxL pins has active high polarity
 0 = Output signal on PWMxL pins has active low polarity

Note: See Section 24. "Device Configuration" for information about other configuration bits on this register.

| | | | |
|------------------------------------|------------------|--------------------------------|--------------------|
| Legend: | | | |
| R = Readable bit | W = Writable bit | U = Unimplemented, read as '0' | |
| -n = Value at POR | '1' = Bit is set | '0' = Bit is cleared | x = Bit is unknown |
| P = Programmable configuration bit | | | |

15.3 PWM Time Base

The PWM time base is provided by a 15-bit timer with a prescaler and postscaler (see Figure 15-2). The 15 bits of the time base are accessible via the PTMR register. PTMR<15> is a read-only status bit, PTDIR, that indicates the present count direction of the PWM time base. If the PTDIR status bit is cleared, PTMR is counting upwards. If PTDIR is set, PTMR is counting downwards.

The time base is enabled/disabled by setting/clearing the PTEN bit (PTCON<15>). PTMR is not cleared when the PTEN bit is cleared in software.

Figure 15-2: PWM Time Base Block Diagram

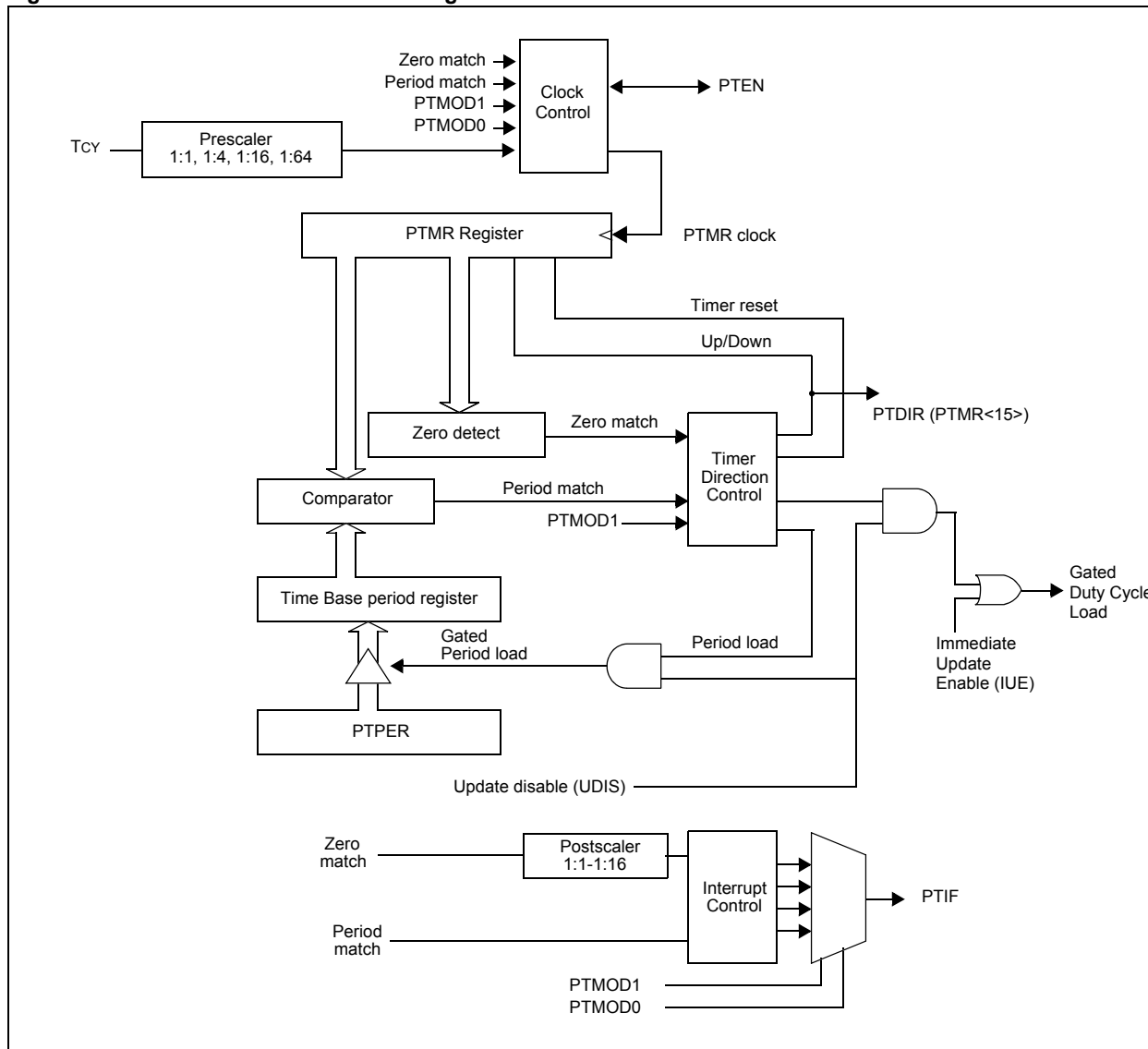

The PWM time base can be configured for four different modes of operation, such as:

- Free Running mode
- Single Event mode
- Continuous Up/Down Count mode
- Continuous Up/Down Count mode with interrupts for double-updates.

These four modes are selected by the PTMOD<1:0> control bits (PTCON<1:0>).

Note: The mode of the PWM time base determines the type of PWM signal that is generated by the module (See Section 15.4.2, Section 15.4.3 and Section 15.4.4 for more details).

15.3.1 Free Running Mode

During Free Running mode, the time base will count upwards until the value in the PTPER register is matched. The PTMR register is reset on the following input clock edge and the time base will continue counting upwards as long as the PTEN bit remains set.

15.3.2 Single-Event Mode

In the Single Event Counting mode, the PWM time base starts counting upwards when the PTEN bit is set. When the PTMR value matches the PTPER register, the PTMR register will be reset on the following input clock edge and the PTEN bit will be cleared by the hardware to halt the time base.

15.3.3 Up/Down Counting Modes

For the Continuous Up/Down Counting modes, the PWM time base will count upwards until the value in the PTPER register is matched. The timer will begin counting downwards on the following input clock edge and continue counting down until it reaches '0'. The PTDIR bit PTMR<15> is read-only and indicates the counting direction. The PTDIR bit is set when the timer counts downwards.

15.3.4 PWM Time Base Prescaler

The input clock to PTMR, (Tcy) has prescaler options of 1:1, 1:4, 1:16 or 1:64 selected by control bits PTCKPS<1:0> (PTCON<3:2>). The prescaler counter is cleared when any of the following occurs:

- A write to the PTMR register
- A write to the PTCOIN register
- Any device reset

The PTMR register is not cleared when PTCOIN is written.

15.3.5 PWM Time Base Postscaler

The match output of PTMR can optionally be post-scaled through a 4-bit postscaler (which gives a 1:1 to 1:16 scaling inclusive) to generate an interrupt. The postscaler is useful when the PWM duty cycle does not need to be updated every PWM cycle.

The postscaler counter is cleared when any of the following occurs:

- A write to the PTMR register
- A write to the PTCOIN register
- Any device reset

The PTMR register is not cleared when PTCOIN is written.

15.3.6 PWM Time Base Interrupts

The interrupt signals generated by the PWM time base depend on the mode selection bits, PTMOD<1:0> (PTCON<1:0>), and the time base postscaler bits, PTOPS<3:0> (PTCON<7:4>).

- **Free Running Mode**

When the PWM time base is in the Free Running mode (PTMOD<1:0> = 00), an interrupt is generated when the PTMR register is reset to '0', due to a match with the PTPER register. The postscaler selection bits may be used in this mode of the timer to reduce the frequency of the interrupt events.

- **Single Event Mode**

When the PWM time base is in the Single Event mode (PTMOD<1:0> = 01), an interrupt is generated when the PTMR register is reset to '0' due to a match with the PTPER register. The PTEN bit (PTCON<15>) is also cleared at this time to inhibit further PTMR increments. The postscaler selection bits have no effect in this mode of the timer.

- **Up/Down Counting Mode**

In the Up/Down Counting mode (PTMOD<1:0> = 10), an interrupt event is generated each time the value of the PTMR register becomes zero and the PWM time base begins to count upwards. The postscaler selection bits may be used in this mode of the timer to reduce the frequency of the interrupt events.

- **Up/Down Counting Mode with Double Updates**

In the Double Update mode (PTMOD<1:0> = 11), an interrupt event is generated each time the PTMR register is equal to zero and each time a period match occurs. The postscaler selection bits have no effect in this mode of the timer.

The Double Update mode allows the control loop bandwidth to be doubled because the PWM duty cycles can be updated twice per period. Every rising and falling edge of the PWM signal can be controlled using the double update mode.

15.3.7 PWM Period

The PTPER register sets the counting period for PTMR. The user must write a 15-bit value to PTPER<14:0>. When the value in PTMR<14:0> matches the value in PTPER<14:0>, the time base will either reset to '0' or reverse the count direction on the next clock input edge. The action taken depends on the operating mode of the time base.

The time base period is double buffered to allow on-the-fly period changes of the PWM signal without glitches. The PTPER register serves as a buffer register to the actual time base period register, which is not accessible by the user. The PTPER register contents are loaded into the actual time base period register during Free Running and Single Event modes and Up/Down Counting modes.

- Free Running and Single Event modes: when the PTMR register is reset to zero after a match with the PTPER register.
- Up/Down Counting modes: When the PTMR register is zero.

The value held in the PTPER register is automatically loaded into the time base period register when the PWM time base is disabled (PTEN = 0).

Figure 15-3 and Figure 15-4 indicate the times when the contents of the PTPER register are loaded into the time base period register.

Figure 15-3: PWM Period Buffer Updates in Free Running Count Mode

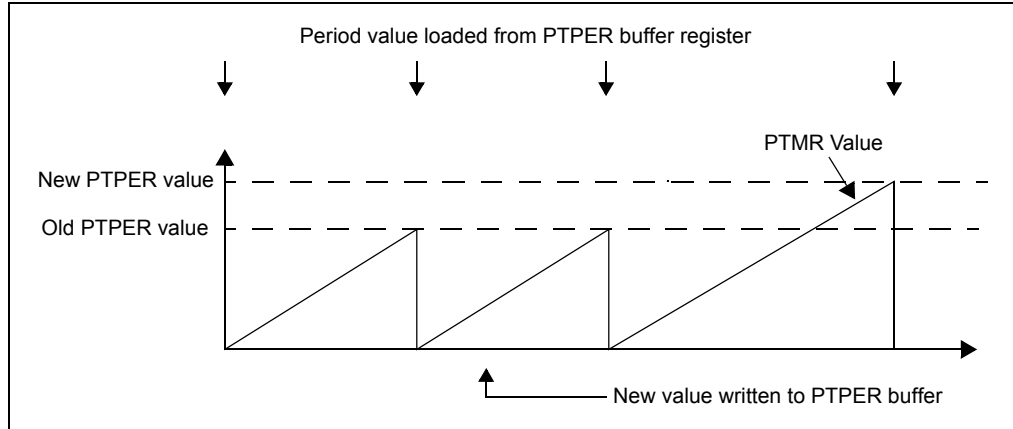

The PWM period can be determined from the following formula:

Equation 15-1: PWM Period Calculation for Free Running Count Mode (PTMOD = 10 or 11)

$$PTPER = \frac{FCY}{FPWM \cdot (PTMR \text{ Prescaler})} - 1$$

Example:

FCY = 20 MHz
 FPWM = 20,000 Hz
 PTMR Prescaler = 1:1

$$PTPER = \frac{20,000,000}{20,000 \cdot 1} - 1$$

$$= 1000 - 1$$

$$= 999$$

Figure 15-4: PWM Period Buffer Updates in Up/Down Counting Modes

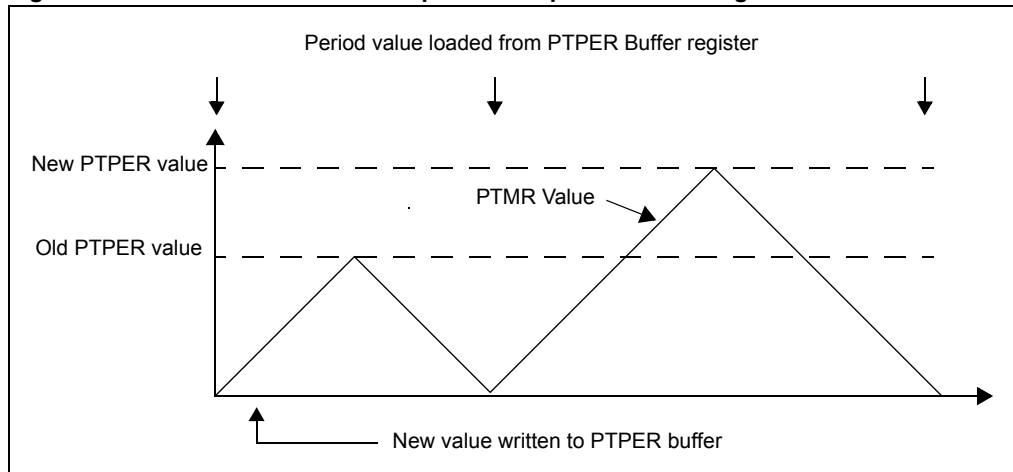

Equation 15-2: PWM Period Calculation in Up/Down Counting Modes (PTMOD = 00 or 01)

$$PTPER = \frac{FCY}{FPWM \cdot (PTMR \text{ Prescaler}) \cdot 2} - 1$$

Example:

FCY = 20 MHz
 FPWM = 20,000 Hz
 PTMR Prescaler = 1:1

$$PTPER = \frac{20,000,000}{20,000 \cdot 1 \cdot 2} - 1$$

$$= 500 - 1$$

$$= 499$$

15.4 PWM Duty Cycle Comparison Units

The MCPWM module has four PWM generators. There are four 16 bit special function registers used to specify duty cycle values for the PWM generators:

- PDC1
- PDC2
- PDC3
- PDC4

In subsequent discussions, PDCx refers to any of the four PWM duty cycle registers.

15.4.1 PWM Duty Cycle Resolution

The maximum resolution (in bits) for a given device oscillator and PWM frequency can be determined using the formula in Equation 15-3.

Equation 15-3: PWM Resolution

$$Resolution = \frac{\log\left(\frac{2TPWM}{TCY}\right)}{\log(2)}$$

The PWM resolutions and frequencies are shown in Table 15-2 for a selection of execution speeds and PTPER values. The PWM frequencies in Table 15-2 are for edge-aligned (Free Running PTMR) PWM mode. For center aligned modes (Up/Down PTMR mode), the PWM frequencies will be 1/2 the values as indicated in Table 15-3.

Table 15-2: Example PWM Frequencies and Resolutions, 1:1 Prescaler, Free Running Count Mode PWM and No Dead Time

| T _{CY} (FCY) | PTPER Value | PDCx Value for 100% | PWM Resolution | PWM Frequency |
|-----------------------|-------------|---------------------|----------------|---------------|
| 33 ns (30 MHz) | 0x7FFE | 0xFFFFE | 16 bits | 915 Hz |
| 33 ns (30 MHz) | 0x3FE | 0x7FE | 11 bits | 29.3 kHz |
| 50 ns (20 MHz) | 0x7FFE | 0xFFFFE | 16 bits | 610 Hz |
| 50 ns (20 MHz) | 0x1FE | 0x3FE | 10 bits | 39.1 kHz |
| 100 ns (10 MHz) | 0x7FFE | 0xFFFFE | 16 bits | 305 Hz |
| 100 ns (10 MHz) | 0xFE | 0x1FE | 9 bits | 39.1 kHz |
| 200 ns (5 MHz) | 0x7FFE | 0xFFFFE | 16 bits | 153 Hz |
| 200 ns (5 MHz) | 0x7E | 0xFE | 8 bits | 39.1 kHz |

Table 15-3: Example PWM Frequencies and Resolutions, 1:1 Prescaler, Up/Down Counting Mode PWM and No Dead Time

| T _{CY} (F _{CY}) | PTPER Value | PDCx Value for 100% | PWM Resolution | PWM Frequency |
|------------------------------------|-------------|---------------------|----------------|---------------|
| 33 ns (30 MHz) | 0x7FFE | 0xFFFE | 16 bits | 458 Hz |
| 33 ns (30 MHz) | 0x3FFE | 0x7FFE | 15 bits | 916 Hz |
| 50 ns (20 MHz) | 0x7FFE | 0xFFFE | 16 bits | 305 Hz |
| 50 ns (20 MHz) | 0x1FFE | 0x3FFE | 14 bits | 1.22 kHz |
| 100 ns (10 MHz) | 0x7FFE | 0xFFFE | 16 bits | 153 Hz |
| 100 ns (10 MHz) | 0xFFE | 0x1FFE | 13 bits | 1.22 kHz |
| 200 ns (5 MHz) | 0x7FFE | 0xFFFE | 16 bits | 76.3 Hz |
| 200 ns (5 MHz) | 0x7FE | 0xFFE | 12 bits | 1.22 kHz |

For Free Running Up/Down Counting modes, the duty cycle can be calculated using the formulas shown in Equation 15-4.

Equation 15-4: Duty Cycle Calculation for Free Running and Up/Down Counting Modes

$$\text{Duty cycle for Free Running Mode: } \frac{PDCx - DT}{PTPER + 1}$$

$$\text{Duty cycle for Up/Down Mode: } \frac{PDCx - DT}{(PTPER + 1) \cdot 2}$$

Note 1: DT (Dead Time) is the DTA<5:0> or DTB<5:0> register value.

2: For Independent PWM mode, ignore the value of DT.

The MCPWM module has the ability to produce PWM signal edges with T_{CY}/2 resolution. PTMR increments every T_{CY} with a 1:1 prescaler. To achieve T_{CY}/2 edge resolution, PDCx<15:1> is compared to PTMR<14:0> to determine a duty cycle match. PDCx<0> determines whether the PWM signal edge will occur at the T_{CY} or the T_{CY}/2 boundary. When a 1:4, 1:16 or a 1:64 prescaler is used with the PWM time base, PDCx<0> is compared to the MSb of the prescaler counter clock to determine when the PWM edge should occur.

PTMR and PDCx resolutions are depicted in Figure 15-5. It is shown that PTMR resolution is T_{CY} and PDCx resolution is T_{CY}/2 for 1:1 prescaler selection.

Figure 15-5: PTMR and PDCx Resolution Timing Diagram. Free Running Mode and 1:1 Prescaler Selection

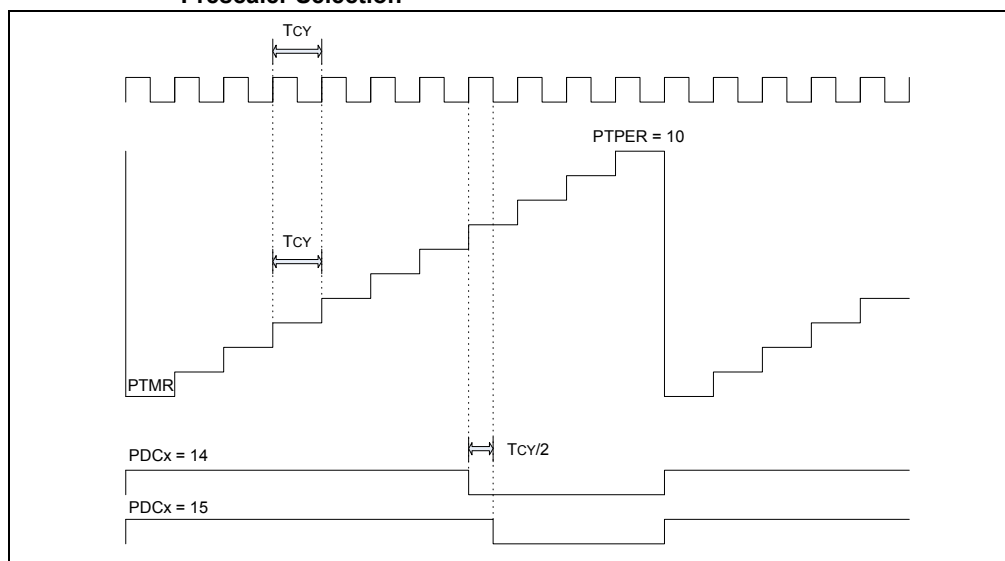
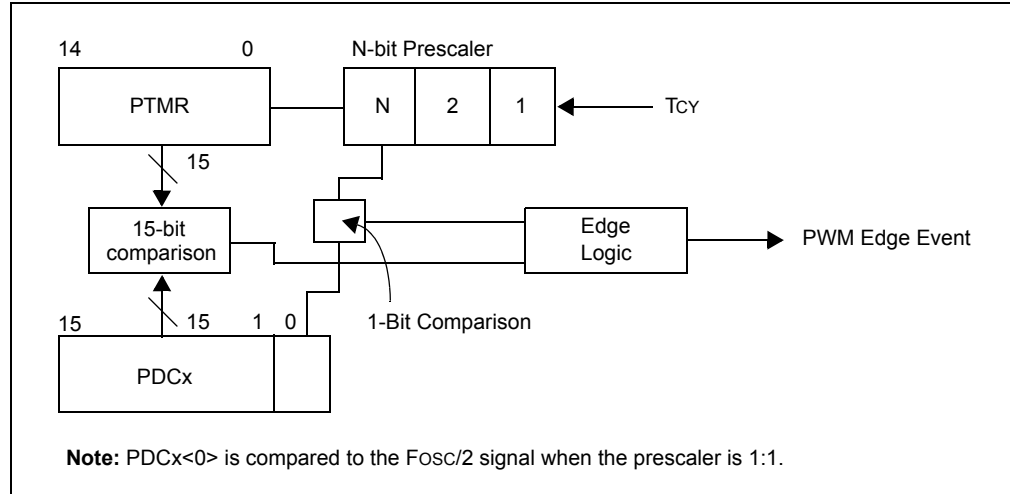

Figure 15-6: Duty Cycle Comparison Logic



15.4.2 Edge Aligned PWM

Edge aligned PWM signals are produced by the module when the PWM time base is operating in the Free Running mode. The output signal for a given PWM channel has a period specified by the value loaded in PTPER and a duty cycle specified by the appropriate PDCx register (see Figure 15-7). Assuming a non-zero duty cycle and no immediate updates are enabled (IUE = 0), the outputs of all enabled PWM generators will be driven active at the beginning of the PWM period (PTMR = 0). Each PWM output will be driven inactive when the value of PTMR matches the duty cycle value of the PWM generator.

If the value in the PDCx register is zero, then the output on the corresponding PWM pin will be inactive for the entire PWM period. In addition, the output on the PWM pin will be active for the entire PWM period if the value in the PDCx register is greater than the value held in the PTPER register.

If immediate updates are enabled (IUE = 1), the new duty cycle value will be loaded at the time the new value is written to any active PDC register.

Figure 15-7: Edge-Aligned PWM

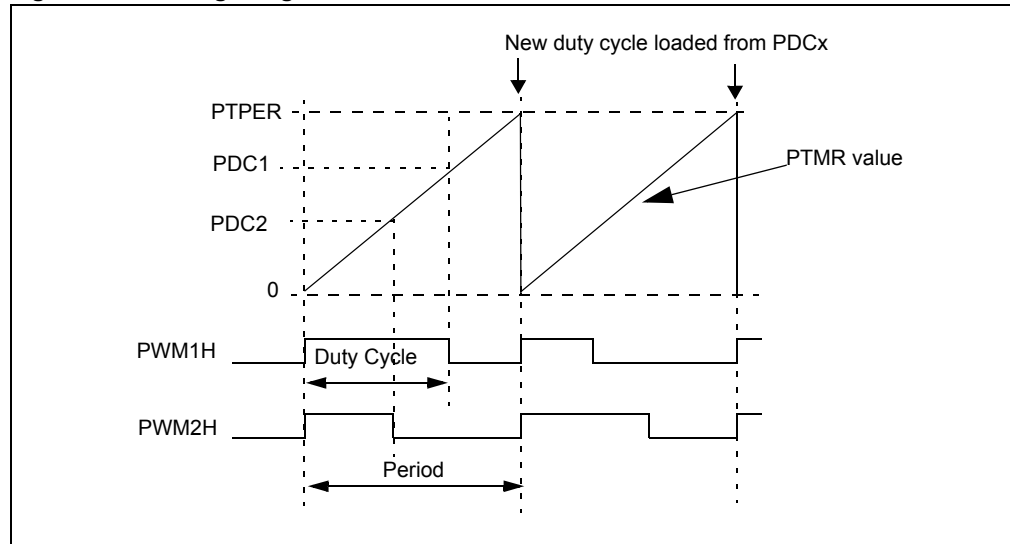

15.4.3 Single Event PWM Operation

The PWM module will produce single pulse outputs when the PWM time base is configured for the single event mode (PTMOD<1:0> = 01). This mode of operation is useful for driving certain types of electronically commutated motors. In particular, this mode is useful for high-speed SR motor operation. Only edge-aligned outputs may be produced in the Single Event mode.

In Single Event mode, the PWM I/O pin(s) are driven to the active state when the PTEN bit is set. When a match with a duty cycle register occurs, the PWM I/O pin is driven to the inactive state. When a match with the PTPER register occurs, the PTMR register is cleared, all active PWM I/O pins are driven to the inactive state, the PTEN bit is cleared and an interrupt is generated. Operation of the PWM module will stop until the PTEN is set again in software.

Figure 15-8: Single Event PWM Operation

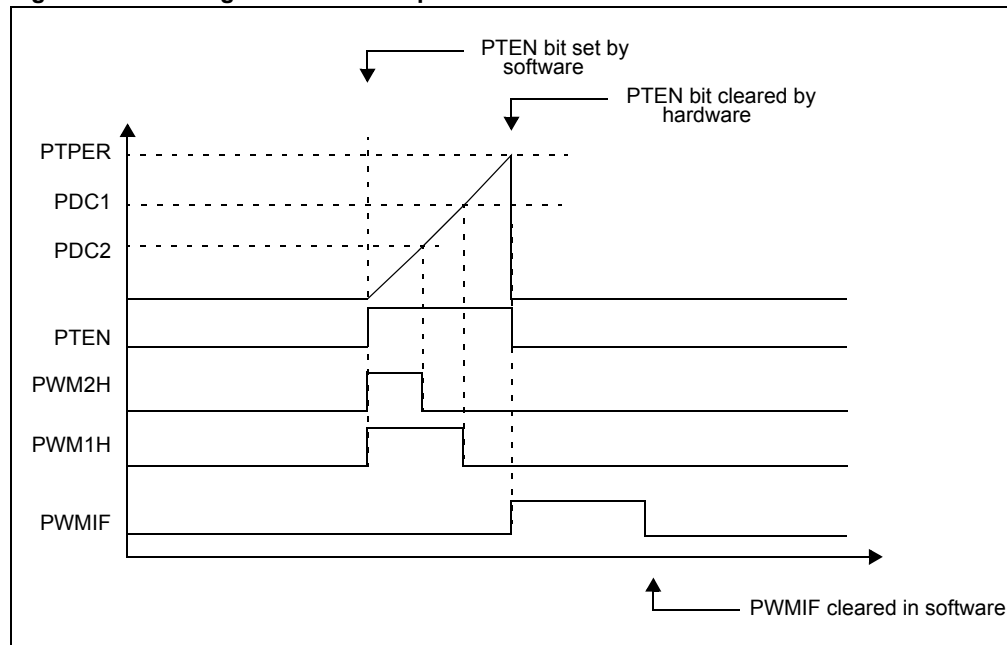

15.4.4 Center Aligned PWM

Center aligned PWM signals are produced by the module when the PWM time base is configured in one of the two Up/Down Counting modes ($PTMOD<1:0> = 1x$).

The PWM compare output is driven to the active state when the value of the Duty Cycle register matches the value of PTMR and the PWM time base is counting downwards ($PTDIR = 1$). The PWM compare output will be driven to the inactive state when the PWM time base is counting upwards ($PTDIR = 0$) and the value in the PTMR register matches the duty cycle value.

If the value in a particular Duty Cycle register is zero, then the output on the corresponding PWM pin will be inactive for the entire PWM period. In addition, the output on the PWM pin will be active for the entire PWM period if the value in the Duty Cycle register is greater than the value held in the PTPER register.

Figure 15-9: Center Aligned PWM

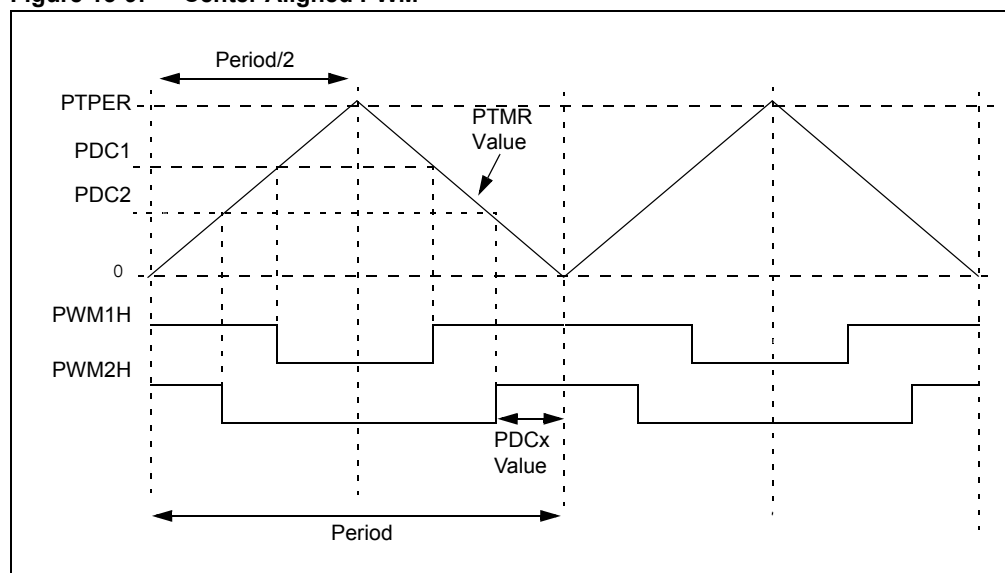

15.4.5 Duty Cycle Register Buffering

The four PWM duty cycle registers, PDC1-PDC4, are buffered to allow glitchless updates of the PWM outputs. For each generator, there is the PDCx register (buffer register) that is accessible by the user and the non-memory mapped Duty Cycle register that holds the actual compare value. The PWM duty cycle is updated with the value in the PDCx register at specific times in the PWM period to avoid glitches in the PWM output signal.

When the PWM time base is operating in the Free Running or Single Event modes ($PTMOD<1:0> = 0x$), the PWM duty cycle is updated whenever a match with the PTPER register occurs and PTMR is reset to '0'.

Note: Any write to the PDCx registers will immediately update the duty cycle when the PWM time base is disabled ($PTEN = 0$). This allows a duty cycle change to take effect before PWM signal generation is enabled.

When the PWM time base is operating in the Up/Down Counting mode ($PTMOD<1:0> = 10$), duty cycles are updated when the value of the PTMR register is zero and the PWM time base begins to count upwards. Figure 15-10 indicates the times when the duty cycle updates occur for this mode of the PWM time base.

When the PWM time base is in the Up/Down Counting mode with double updates ($PTMOD<1:0> = 11$), duty cycles are updated when the value of the PTMR register is zero and when the value of the PTMR register matches the value in the PTPER register. Figure 15-11 indicates the times when the duty cycle updates occur for this mode of the PWM time base.

Figure 15-10: Duty Cycle Update Times in Up/Down Count Mode

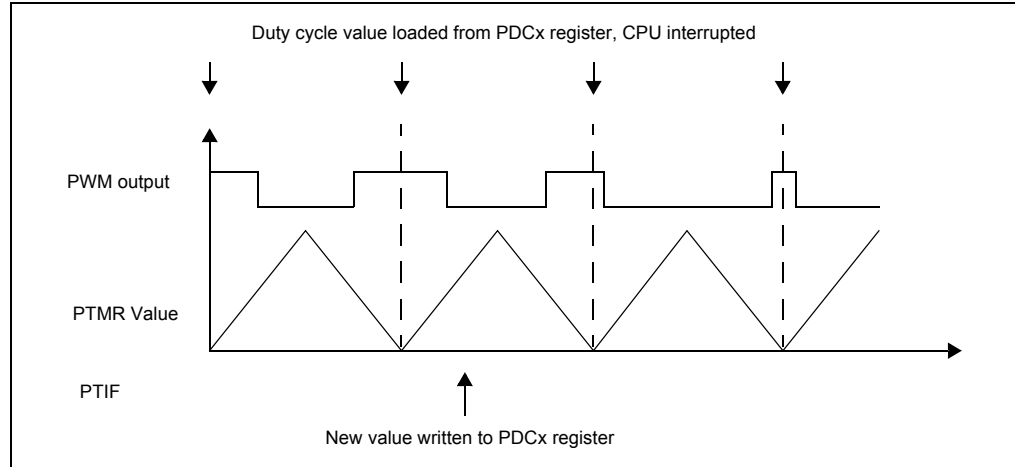
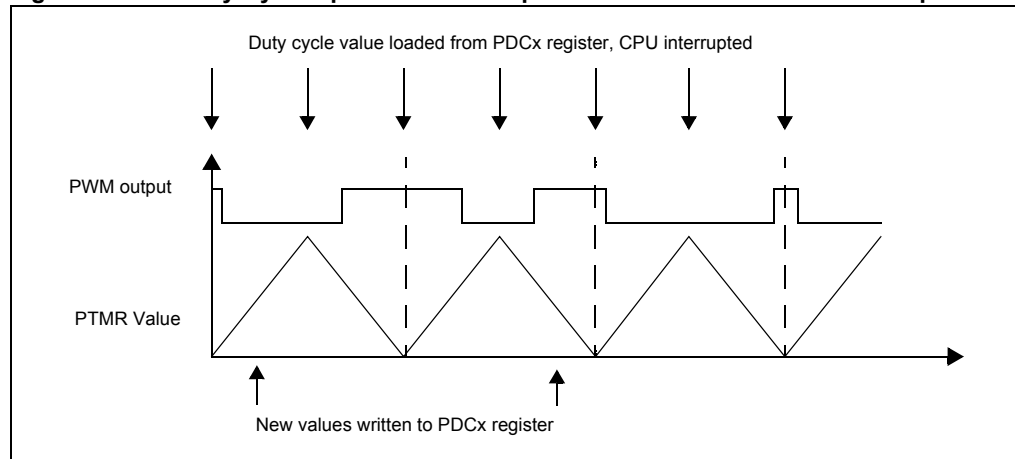

Figure 15-11: Duty Cycle Update Times in Up/Down Count Mode with Double Updates



15.4.6 PWM Duty Cycle Immediate Updates

When the Immediate Update Enable bit is set ($IUE = 1$), any write to the duty cycle registers will update the new duty cycle value immediately. This feature gives the option to the user to allow immediate updates of the active PWM duty cycle registers instead of waiting for the end of the current time base period. System stability is improved in closed loop servo applications by reducing the delay between system observation and the issuance of system corrective commands when immediate updates are enabled ($IUE = 1$).

If the PWM output is active at the time the new duty cycle is written and the new duty cycle is less than the current time base value, the PWM pulse-width will be shortened. If the PWM output is active at the time the new duty cycle is written and the new duty cycle is greater than the current time base value, the PWM pulse width will be lengthened. If the PWM output is inactive when the new duty cycle is written and the new duty cycle is greater than the current time base value, the PWM output will become active immediately and will remain active for the new written duty cycle value.

Figure 15-12 indicates the times when the duty cycle updates occur when immediate updates are enabled ($IUE = 1$).

Note: The IUE bit is not implemented on the dsPIC30F6010 device.

Figure 15-12: Duty Cycle Update Times When Immediate Updates Are Enabled (IUE = 1)

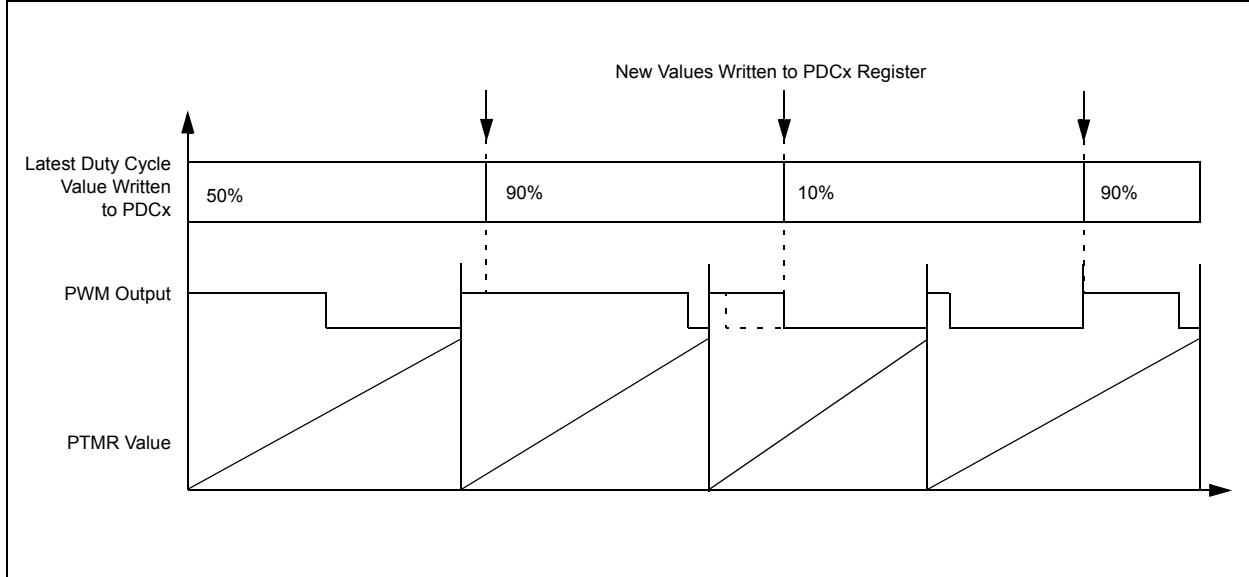

15.5 Complementary PWM Output Mode

The Complementary Output mode is used to drive inverter loads similar to the one shown in Figure 15-13. This inverter topology is typical for ACIM and BLDC applications. In the Complementary Output mode, a pair of PWM outputs cannot be active simultaneously. Each PWM channel and output pin pair is internally configured as shown in Figure 15-14. A dead time may be optionally inserted during device switching where both outputs are inactive for a short period (Refer to **Section 15.6 “Dead Time Control”**).

Figure 15-13: Typical Load for Complementary PWM Outputs

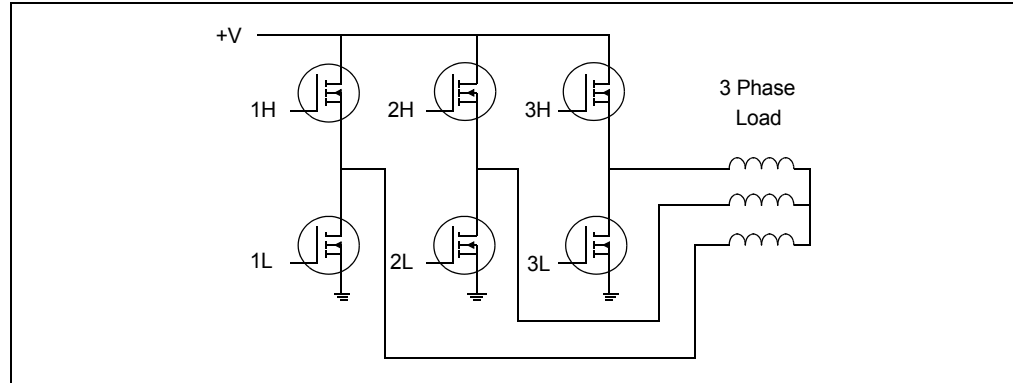

The Complementary mode is selected for each PWM I/O pin pair by clearing the appropriate PMODx bit in PWMCON1. The PWM I/O pins are set to complementary mode by default upon a device reset.

Figure 15-14: PWM Channel Block Diagram, Complementary Mode

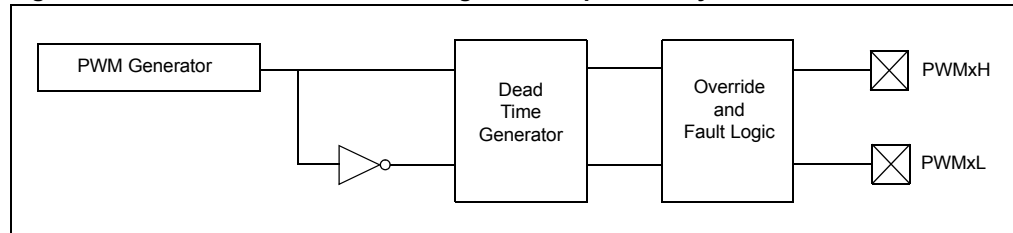

15.6 Dead Time Control

Dead time generation is automatically enabled when any of the PWM I/O pin pairs are operating in the Complementary Output mode. Because the power output devices cannot switch instantaneously, some amount of time must be provided between the turn-off event of one PWM output in a complementary pair and the turn-on event of the other transistor.

The 6-output PWM module has one programmable dead time. The 8-output PWM module allows two different dead times to be programmed. These two dead times may be used in one of two methods described below to increase user flexibility:

- The PWM output signals can be optimized for different turn-off times in the high-side and low-side transistors. The first dead time is inserted between the turn-off event of the lower transistor of the complementary pair and the turn-on event of the upper transistor. The second dead time is inserted between the turn-off event of the upper transistor and the turn-on event of the lower transistor.
- The two dead times can be assigned to individual PWM I/O pin pairs. This operating mode allows the PWM module to drive different transistor/load combinations with each complementary PWM I/O pin pair.

15.6.1 Dead Time Generators

Each complementary output pair for the PWM module has a 6-bit down counter that is used to produce the dead time insertion. As shown in Figure 15-15, each dead time unit has a rising and falling edge detector connected to the duty cycle comparison output.

One of the two possible dead times is loaded into the timer on the detected PWM edge event. Depending on whether the edge is rising or falling, one of the transitions on the complementary outputs is delayed until the timer counts down to zero. A timing diagram indicating the dead time insertion for one pair of PWM outputs is shown in Figure 15-16. The use of two different dead times for the rising and falling edge events has been exaggerated in the figure for clarity.

Figure 15-15: Dead Time Unit Block Diagram for One Output Pin Pair

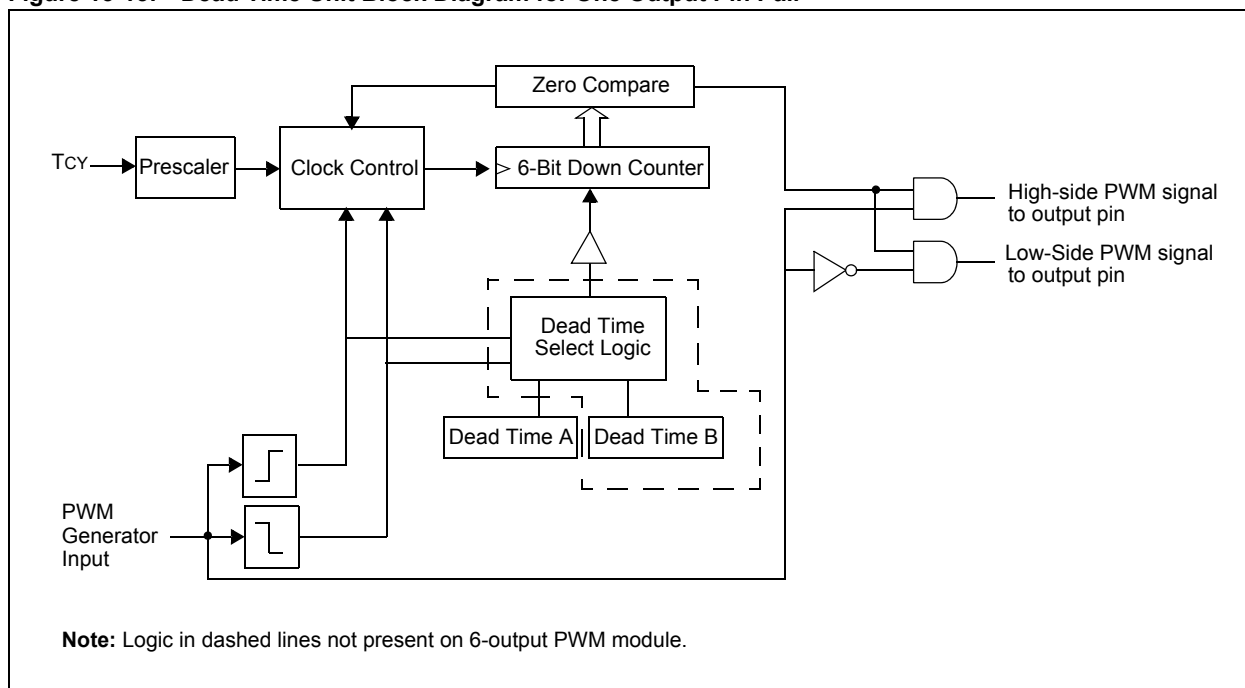
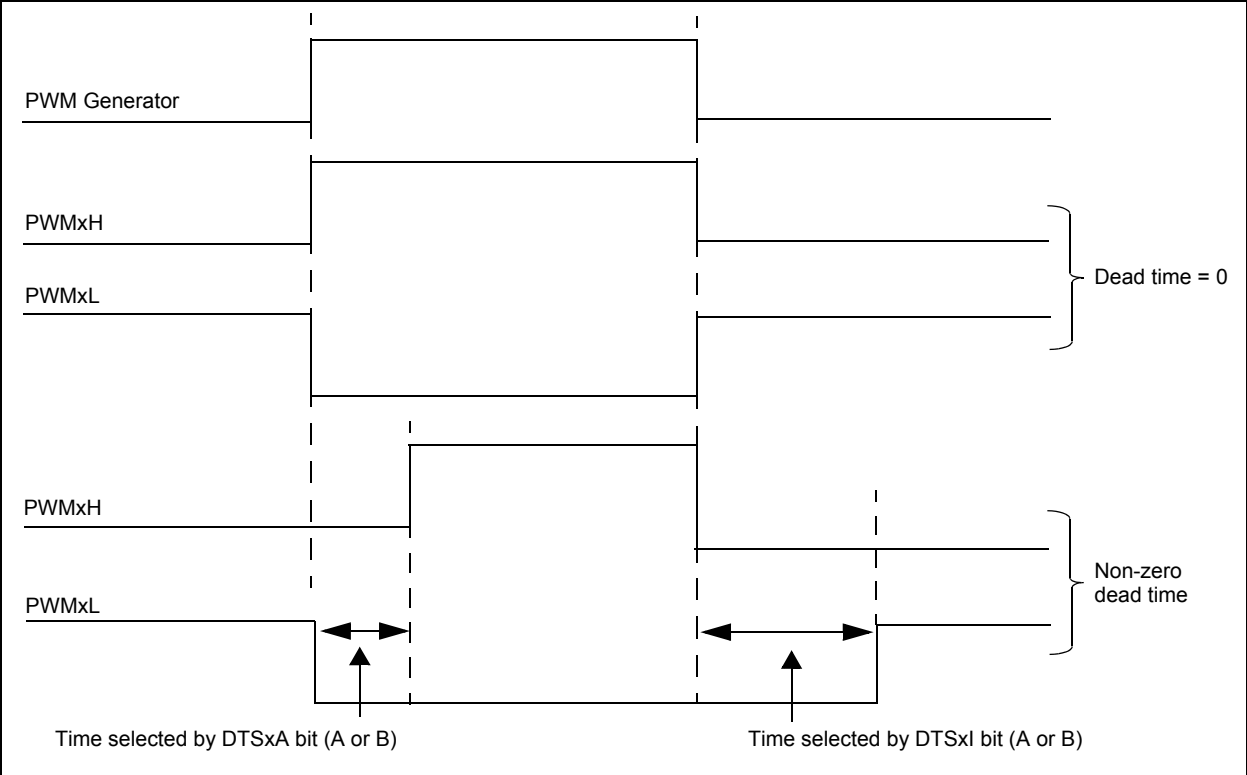

Figure 15-16: Dead Time Insertion Diagram



15.6.2 Dead Time Assignment

Note: The dead time assignment logic is only applicable to DSC[®] dsPIC variants that contain the 8-output PWM module. The 6-output PWM module uses dead time A only.

The DTCON2 register contains control bits that allow two programmable dead times to be assigned to each of the complementary outputs. There are two dead time assignment control bits for each of the complementary outputs. For example, the DTS1A and DTS1I control bits select the dead times to be used for the PWM1H/PWM1L complementary output pair. The pair of dead time selection control bits are referred to as the 'dead-time-select-active' and 'dead-time-select-inactive' control bits, respectively. The function of each bit in a pair is as follows:

- The DTSxA control bit selects the dead time that is to be inserted before the high-side output is driven active.
- The DTSxI control bit selects the dead time that is to be inserted before the low-side PWM active is driven active.

Table 15-4 summarizes the function of each dead time selection control bit.

Table 15-4: Dead Time Selection Control Bits

| Bit | Function |
|-------|---|
| DTS1A | Selects PWM1H/PWM1L dead time inserted before PWM1H is driven active. |
| DTS1I | Selects PWM1H/PWM1L dead time inserted before PWM1L is driven active. |
| DTS2A | Selects PWM1H/PWM1L dead time inserted before PWM2H is driven active. |
| DTS2I | Selects PWM1H/PWM1L dead time inserted before PWM2L is driven active. |
| DTS3A | Selects PWM1H/PWM1L dead time inserted before PWM3H is driven active. |
| DTS3I | Selects PWM1H/PWM1L dead time inserted before PWM3L is driven active. |
| DTS4A | Selects PWM1H/PWM1L dead time inserted before PWM4H is driven active. |
| DTS4I | Selects PWM1H/PWM1L dead time inserted before PWM4L is driven active. |

15.6.3 Dead Time Ranges

Dead time A and dead time B are set by selecting an input clock prescaler value and a 6-bit unsigned dead time count value. Four input clock prescaler selections have been provided to allow a suitable range of dead times based on the device operating frequency. The clock prescaler option may be selected independently for each of the two dead time values. The dead time clock prescaler values are selected using the DTAPS<1:0> and DTBPS<1:0> control bits in the DTCON1 SFR. The following clock prescaler options may be selected for each of the dead time values:

- TCY
- 2 TCY
- 4 TCY
- 8 TCY

Equation 15-5: Dead Time Calculation

$$DT = \frac{\text{Dead Time}}{\text{Prescale Value} \cdot TCY}$$

Note: DT (Dead Time) is the DTA<5:0> or DTB<5:0> register value.

Table 15-5 shows example dead time ranges as a function of the input clock prescaler selected and the device operating frequency.

Table 15-5: Example Dead Time Ranges

| T _{CY} (F _{CY}) | Prescaler Selection | Resolution | Dead Time Range |
|------------------------------------|---------------------|------------|-----------------|
| 33 ns (30 MHz) | 4 T _{CY} | 130 ns | 130 ns - 9 μs |
| 50 ns (20 MHz) | 4 T _{CY} | 200 ns | 200 ns - 12 μs |
| 100 ns (10 MHz) | 2 T _{CY} | 200 ns | 200 ns - 12 μs |
| 100 ns (10 MHz) | 1 T _{CY} | 100 ns | 100 ns - 6 μs |

15.6.4 Dead Time Distortion

For small PWM duty cycles, the ratio of dead time to the active PWM time may become large. At the extreme case, when the duty cycle is lesser than or equal to the programmed duty cycle, no PWM pulse will be generated. In these cases, the inserted dead time will introduce distortion into waveforms produced by the PWM module. The user can ensure that dead time distortion is minimized by keeping the PWM duty cycle at least three times larger than the dead time. Dead time distortion can also be corrected by other techniques such as closed loop current control.

A similar effect occurs for duty cycles near 100%. The maximum duty cycle used in the application should be chosen such that the minimum inactive time of the PWM signal is at least three times larger than the dead time.

15.7 Independent PWM Output Mode

An Independent PWM Output mode is useful for driving loads such as the one shown in Figure 15-17. A particular PWM output pair is in the Independent Output mode when the corresponding PMOD bit in the PWMCON1 register is set. The dead time generators are disabled in the Independent mode and there are no restrictions on the state of the pins for a given output pin pair.

Figure 15-17: Asymmetric Inverter

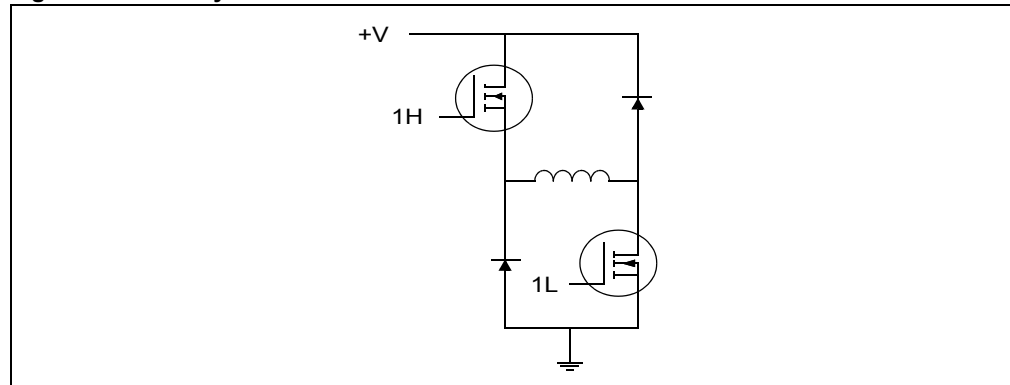
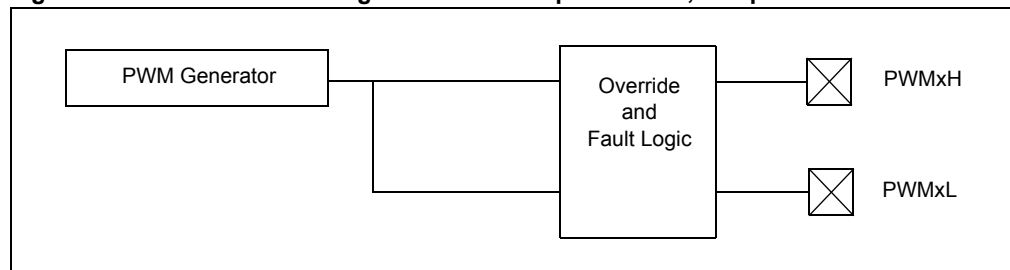

Figure 15-18: PWM Block Diagram for One Output Pin Pair, Independent Mode



15.8 PWM Output Override

The PWM output override bits allow the user to manually drive the PWM I/O pins to specified logic states independent of the duty cycle comparison units. The PWM override bits are useful when controlling various types of electrically commutated motors.

All control bits associated with the PWM output override function are contained in the OVDCON register. The upper half of the OVDCON register contains 8 bits, POVDxx, that determine which PWM I/O pins will be overridden. The lower half of the OVDCON register contains 8 bits, POUTxx, that determine the state of the PWM I/O pin when it is overridden via the POVDxx bit.

The POVD bits are active-low control bits. When the POVD bits are set, the corresponding POUTxx bit will have no effect on the PWM output. When one of the POVD bits is cleared, the output on the corresponding PWM I/O pin will be determined by the state of the POUT bit. When a POUT bit is set, the PWM pin will be driven to its active state. When the POUT bit is cleared, the PWM pin will be driven to its inactive state.

15.8.1 Override Control for Complementary Output Mode

The PWM module will not allow certain overrides when a pair of PWM I/O pins is operating in the Complementary mode. (PMODx = 0) The module will not allow both pins in the output pair to become active simultaneously. The high-side pin in each output pair will always take priority.

Note: Dead time insertion is still performed when PWM channels are overridden manually.

15.8.2 Override Synchronization

If the OSYNC bit is set (PWMCON2<1>), all output overrides performed via the OVDCON register will be synchronized to the PWM time base. Synchronous output overrides will occur at the following times:

- Edge aligned mode, when PTMR is zero,
- Center aligned modes, when PTMR is zero or
- When the value of PTMR matches PTPER.

The override synchronization function, when enabled, can be used to avoid unwanted narrow pulses on the PWM output pins.

15.8.3 Output Override Examples

Figure 15-19 shows an example of a waveform that might be generated using the PWM output override feature. The Figure shows a six-step commutation sequence for a BLDC motor. The motor is driven through a 3-phase inverter as shown in Figure 15-13. When the appropriate rotor position is detected, the PWM outputs are switched to the next commutation state in the sequence. In this example, the PWM outputs are driven to specific logic states. The OVDCON register values used to generate the signals in Figure 15-19 are given in Table 15-6.

The PWM duty cycle registers may be used in conjunction with the OVDCON register. The duty cycle registers controls the current delivered to the load and the OVDCON register controls the commutation (Figure 15-20 shows such an example). The OVDCON register values used to generate the signals in Figure 15-20 are given in Table 15-7.

Table 15-6: PWM Output Override Example 1

| State | OVDCON<15:8> | OVDCON<7:0> |
|-------|--------------|-------------|
| 1 | 00000000b | 00100100b |
| 2 | 00000000b | 00100001b |
| 3 | 00000000b | 00001001b |
| 4 | 00000000b | 00011000b |
| 5 | 00000000b | 00010010b |
| 6 | 00000000b | 00000110b |

Figure 15-19: PWM Output Override Example 1

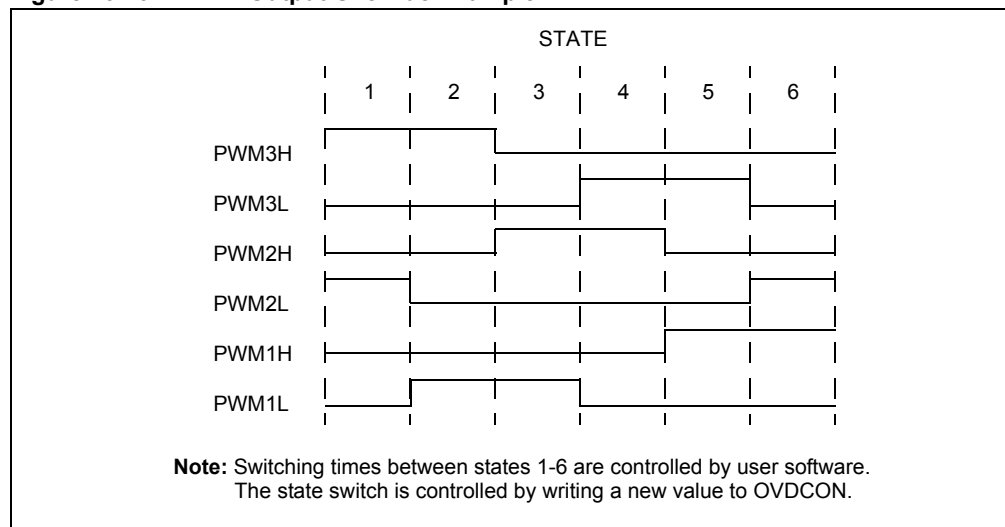
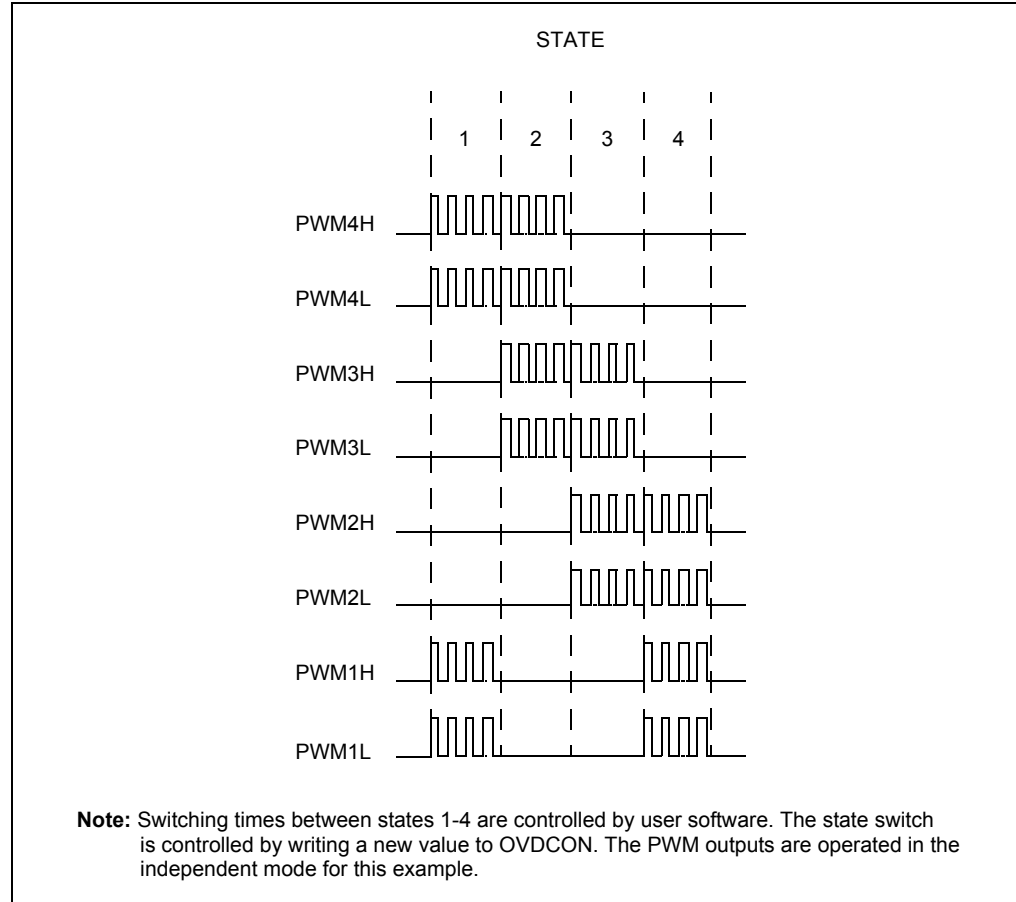

Table 15-7: PWM Output Override Example 2

| State | OVDCON<15:8> | OVDCON<7:0> |
|-------|--------------|-------------|
| 1 | 11000011b | 00000000b |
| 2 | 11110000b | 00000000b |
| 3 | 00111100b | 00000000b |
| 4 | 00001111b | 00000000b |

Figure 15-20: PWM Output Override Example 2



15.9 PWM Output and Polarity Control

The PENxx control bits in PWMCON1 enable the usage of each PWM output pin by the module. When a pin is enabled for PWM output, the PORT and TRIS registers controlling the pin are disabled.

In addition to the PENxx control bits, there are three device configuration bits in the FBORPOR device configuration register that provide PWM output pin control.

- HPOL configuration bit
- LPOL configuration bit
- PWMPIN configuration bit

These three configuration bits work in conjunction with the PWM enable bits (PENxx) located in PWMCON1. The configuration bits ensure that the PWM pins are in the correct state after a device reset occurs.

15.9.1 Output Polarity Control

The polarity of the PWM I/O pins is set during device programming via the HPOL and LPOL configuration bits in the FBORPOR Device Configuration register. The HPOL configuration bit sets the output polarity for the high-side PWM outputs PWM1H-PWM4H. The LPOL configuration bit sets the output polarity for the low-side PWM outputs PWM1L-PWM 4L.

If the polarity configuration bit is programmed to a '1', the corresponding PWM I/O pins will have active-high output polarity. If the polarity configuration bit is programmed to a '0', then the corresponding PWM pins will have active-low polarity.

15.9.2 PWM Output Pin Reset States

The PWMPIN configuration bit determines the behavior of the PWM output pins on a device reset and can be used to eliminate external pull-up/pull-down resistors connected to the devices controlled by the PWM module.

If the PWMPIN configuration bit is programmed to a '1', the PENxx control bits will be cleared on a device reset. Consequently, all PWM outputs will be tri-stated and controlled by the corresponding PORT and TRIS registers.

If the PWMPIN configuration bit is programmed to a '0', the PENxx control bits will be set on a device reset. All PWM pins will be enabled for PWM output at the device reset and will be at their inactive states as defined by the HPOL and LPOL configuration bits.

15.10 PWM Fault Pins

There are two Fault pins, \overline{FLTA} and \overline{FLTB} , associated with the PWM module. When asserted, these pins can optionally drive each of the PWM I/O pins to a defined state. This action takes place without software intervention so that the fault events can be managed quickly.

The Fault pins may have other multiplexed functions depending on the DSC dsPIC device variant. When used as a fault input, each Fault pin is readable via its corresponding PORT register. The FLTA and FLTB pins function as active low inputs so that it is easy to wire-OR many sources to the same input through an external pull-up resistor. When not used with the PWM module, these pins may be used as general purpose I/O or another multiplexed function. Each Fault pin has its own interrupt vector, Interrupt Flag bit, Interrupt Enable bit and Interrupt Priority bits associated with it.

The function of the \overline{FLTA} pin is controlled by the FLTACON register and the function of the \overline{FLTB} pin is controlled by the FLTBCON register.

15.10.1 Fault Pin Enable Bits

The FLTACON and FLTBCON registers each have 4 control bits, FxEN1-FxEN4, that determine whether a particular pair of PWM I/O pins is to be controlled by the fault input pin. To enable a specific PWM I/O pin pair for fault overrides, the corresponding bit should be set in the FLTACON or FLTBCON register.

If all enable bits are cleared in the FLTACON or FLTBCON registers, then that fault input pin has no effect on the PWM module and no fault interrupts will be produced.

15.10.2 Fault States

The FLTACON and FLTBCON special function registers each have 8 bits that determine the state of each PWM I/O pin when the fault input pin becomes active. When these bits are cleared, the PWM I/O pin will be driven to the inactive state. If the bit is set, the PWM I/O pin will be driven to the active state. The active and inactive states are referenced to the polarity defined for each PWM I/O pin (set by HPOL and LPOL device configuration bits).

A special case exists when a PWM module I/O pair is in the Complementary mode and both pins are programmed to be active on a fault condition. The high-side pin will always have priority in the Complementary mode so that both I/O pins cannot be driven active simultaneously.

15.10.3 Fault Input Modes

Each of the fault input pins has two modes of operation:

- **Latched Mode**

When the fault pin is driven low, the PWM outputs will go to the state defined in the FLTxCON register. The PWM outputs will remain in this state until the fault pin is driven high AND the corresponding interrupt flag (FLTxFIF) has been cleared in software. When both of these actions have occurred, the PWM outputs will return to normal operation at the beginning of the next PWM period or half-period boundary regardless of the Immediate Update Enable (IUE) bit value. If the interrupt flag is cleared before the fault condition ends, the PWM module will wait until the fault pin is no longer asserted to restore the outputs.

- **Cycle-by-Cycle Mode**

When the fault input pin is driven low, the PWM outputs will remain in the defined fault states for as long as the fault pin is held low. After the fault pin is driven high, the PWM outputs will return to normal operation at the beginning of the following PWM period (or half-period boundary in center aligned modes) even when immediate updates are enabled.

The operating mode for each fault input pin is selected using the FLTAM and FLTBM control bits (FLTACON<7> and FLTBCON<7>).

15.10.3.1 Entry Into a Fault Condition

When a fault pin is enabled and driven low, the PWM pins are immediately driven to their programmed fault states regardless of the values in the PDCx and OVDCON registers. The fault action has priority over all other PWM control registers.

15.10.3.2 Exit From a Fault Condition

A fault condition must be cleared by the external circuitry driving the fault input pin high and clearing the fault interrupt flag (Latched mode only). After the fault pin condition has been cleared, the PWM module will restore the PWM output signals on the next PWM period or half-period boundary. For edge aligned PWM generation, the PWM outputs will be restored when PTMR = 0. For center aligned PWM generation, the PWM outputs will be restored when PTMR = 0 or PTMR = PTPER, whichever event occurs first.

An exception to these rules will occur when the PWM time base is disabled (PTEN = 0). If the PWM time base is disabled, the PWM module will restore the PWM output signals immediately after the fault condition has been cleared.

15.10.4 Fault Pin Priority

If both fault input pins have been assigned to control a particular pair of PWM pins, the fault states programmed for the $\overline{\text{FLTA}}$ input pin will take priority over the $\overline{\text{FLT B}}$ input pin.

One of the two actions will take place when the Fault A condition has been cleared. If the $\overline{\text{FLT B}}$ input is still asserted, the PWM outputs will return to the states programmed in the $\overline{\text{FLT BCON}}$ register on the next period or half-period boundary. If the $\overline{\text{FLT B}}$ input is not asserted, the PWM outputs will return to normal operation on the next period or half-period boundary.

Note: When the $\overline{\text{FLTA}}$ pin is programmed for Latched mode, the PWM outputs will not return to the Fault B states or normal operation until the Fault A interrupt flag has been cleared and the $\overline{\text{FLTA}}$ pin is de-asserted.

15.10.5 Fault Pin Software Control

Each of the fault pins can be controlled manually in software. Since each fault input is shared with a PORT I/O pin, the PORT pin can be configured as an output by clearing the corresponding TRIS bit. When the PORT bit for the pin is cleared, the fault input will be activated.

Note: The user should exercise caution when controlling the fault inputs in software. If the TRIS bit for the fault pin is cleared, then the fault input cannot be driven externally.

15.10.6 Fault Timing Examples

Figure 15-21: Example Fault Timing, Cycle-by-Cycle Mode

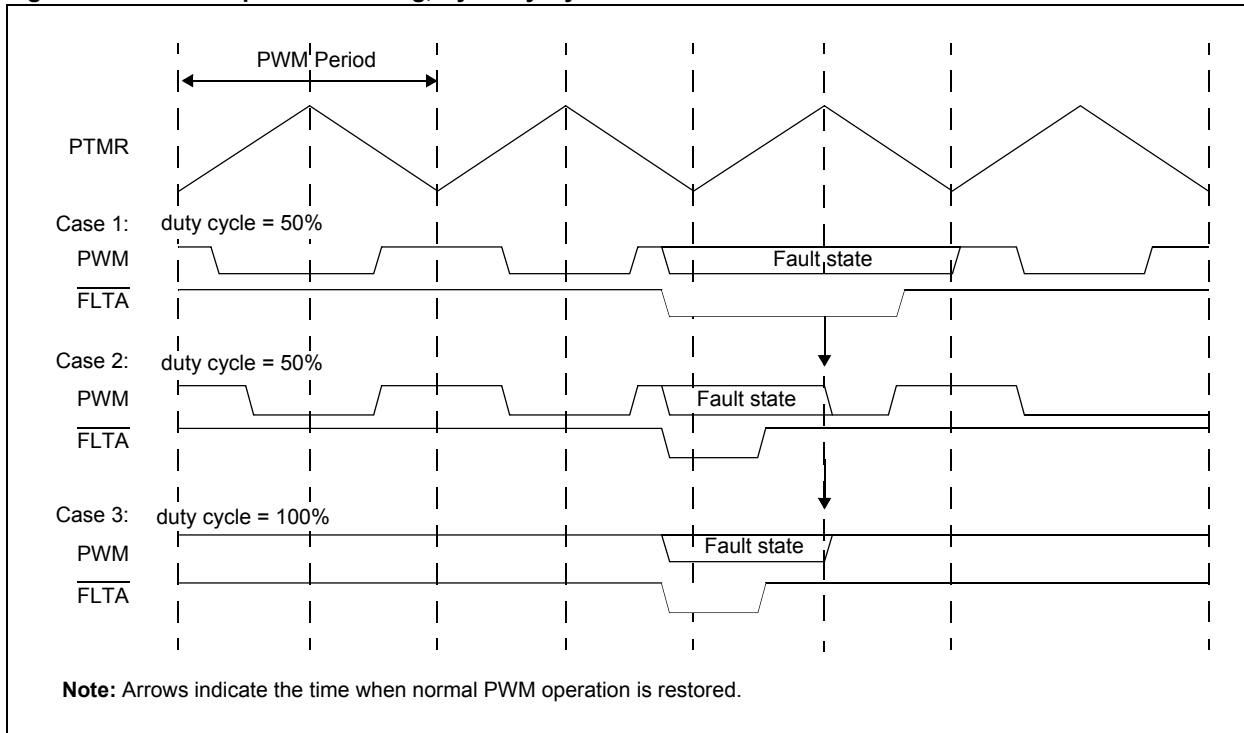

Figure 15-22: Example Fault Timing, Latched Mode

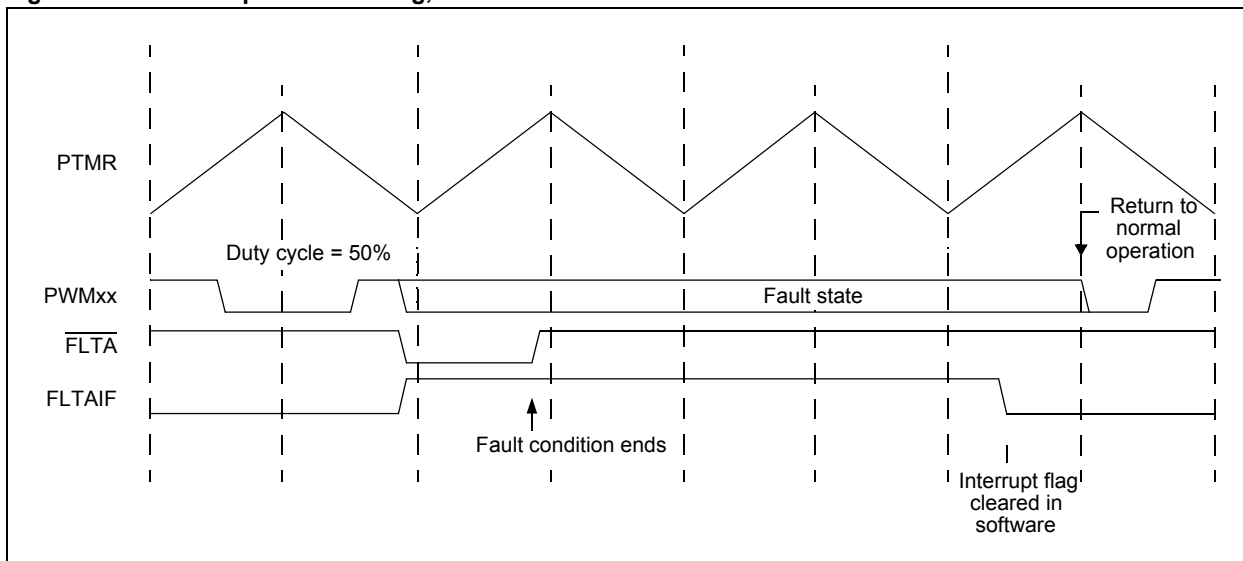
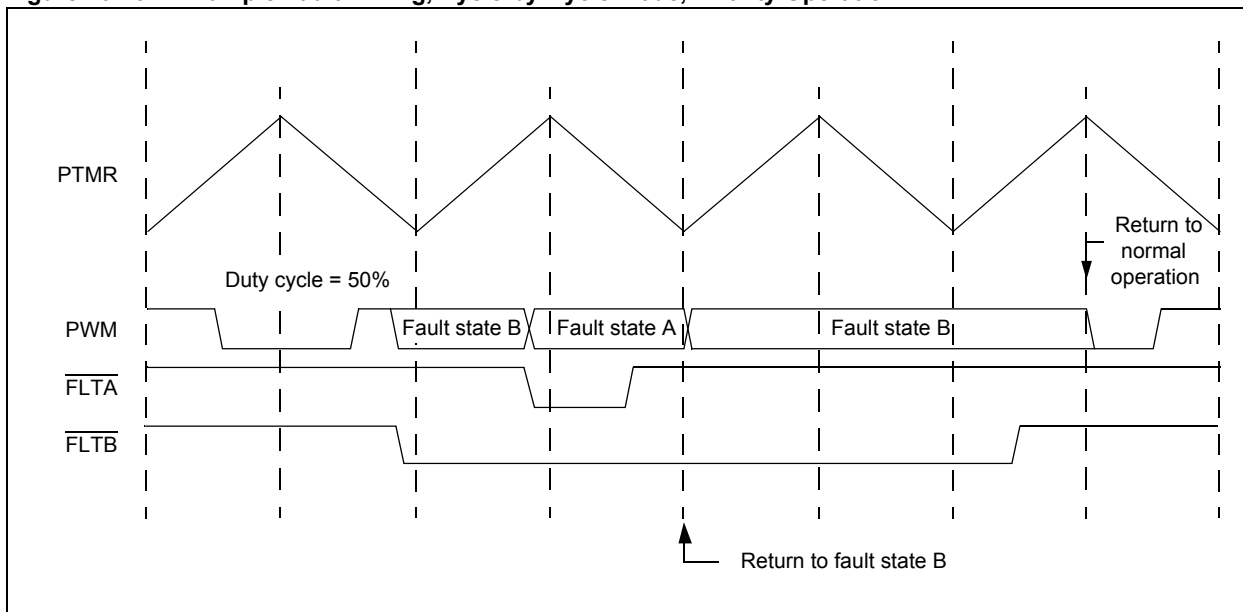

Figure 15-23: Example Fault Timing, Cycle-by-Cycle Mode, Priority Operation



15.11 PWM Update Lockout

In some applications, it is important that all duty cycle and period registers be written before the new values take effect. The update disable feature allows the user to specify when new duty cycle and period values can be used by the module. The PWM update lockout feature is enabled by setting the UDIS control bit (PWMCON2<0>).

The UDIS bit affects all duty cycle registers, PDC1-PDC4 and the PWM time base period buffer, PTPER. To perform an update lockout, the user should perform the following steps:

- Set the UDIS bit
- Write all duty cycle registers and PTPER, if applicable
- Clear the UDIS bit to re-enable updates

Note: Immediate updates must be disabled (IUE = 0) in order to use the PWM update lockout feature.

15.12 PWM Special Event Trigger

The PWM module has a special event trigger that allows A/D conversions to be synchronized to the PWM time base. The A/D sampling and conversion time may be programmed to occur at any point within the PWM period. The special event trigger allows the user to minimize the delay between the time when A/D conversion results are acquired and the time when the duty cycle value is updated.

The PWM special event trigger has one SFR, SEVTCMP, and four postscaler control bits (SEVOPS<3:0>) to control its operation. The PTMR value for which a special event trigger should occur is loaded into the SEVTCMP register.

When the PWM time base is in an Up/Down Counting mode, an additional control bit is required to specify the counting phase for the special event trigger. The count phase is selected using the SEVTDIR control bit in the MSb of SEVTCMP. If the SEVTDIR bit is cleared, the special event trigger will occur on the upward counting cycle of the PWM time base. If the SEVTDIR bit is set, the special event trigger will occur on the downward count cycle of the PWM time base.

15.12.1 Special Event Trigger Enable

The PWM module will always produce the special event trigger signal. This signal may optionally be used by the A/D module. Refer to **Section Section 17. “10-bit A/D Converter”** for more information on using the special event trigger.

15.12.2 Special Event Trigger Postscaler

The PWM special event trigger has a postscaler that allows a 1:1 to 1:16 postscale ratio. The postscaler is useful when synchronized A/D conversions do not need to be performed during every PWM cycle. The postscaler is configured by writing the SEVOPS<3:0> control bits in the PWMCON2 SFR.

The special event output postscaler is cleared on the following events:

- Any write to the SEVTCMP register
- Any device reset

15.13 Operation in Device Power Saving Modes

15.13.1 PWM Operation in Sleep mode

When the device enters Sleep mode, the system clock is disabled. Since the clock for the PWM time base is derived from the system clock source (TCY), it will also be disabled. All enabled PWM output pins will be frozen in the output states that were in effect prior to entering Sleep.

If the PWM module is used to control a load in a power application, it is the user's responsibility to put the PWM module outputs into a 'safe' state prior to executing the PWRSAV instruction. Depending on the application, the load may begin to consume excessive current when the PWM outputs are frozen in a particular output state. For example, the OVDCON register can be used to manually turn off the PWM output pins as shown in Example 15-1.

Example 15-1:

```
; This code example drives all PWM pins to the inactive state
; before executing the PWRSAV instruction.

CLR          OVDCON      ; Force all PWM outputs inactive
PWRSAV      #0          ; Put the device in Sleep mode
SETM.B      OVDCONH     ; Set POVD bits when device wakes
```

The Fault A and Fault B input pins, if enabled to control the PWM pins via the FLTxCN registers, will continue to function normally when the device is in Sleep mode. If one of the fault pins is driven low while the device is in Sleep, the PWM outputs will be driven to the programmed fault states in the FLTxCN register.

The fault input pins also have the ability to wake the CPU from Sleep mode. If the fault interrupt enable bit is set ($FLT_{xIE} = 1$), then the device will wake from Sleep when the fault pin is driven low. If the fault pin interrupt priority is greater than the current CPU priority, then program execution will start at the fault pin interrupt vector location upon wake-up. Otherwise, execution will continue from the next instruction following the $PWRS_{AV}$ instruction.

15.13.2 PWM Operation in Idle Mode

When the device enters Idle mode, the system clock sources remain functional and the CPU stops executing code. The PWM module can optionally continue to operate in Idle mode. The $PTSIDL$ bit ($PTCON<13>$) selects if the PWM module will stop in Idle mode or continue to operate normally.

If $PTSIDL = 0$, the module will operate normally when the device enters Idle mode. The PWM time base interrupt, if enabled, can be used to wake the device from Idle. If the PWM time base interrupt enable bit is set ($PTIE = 1$), then the device will wake from Idle when the PWM time base interrupt is generated. If the PWM time base interrupt priority is greater than the current CPU priority, then program execution will start at the PWM interrupt vector location upon wake-up. Otherwise, execution will continue from the next instruction following the $PWRS_{AV}$ instruction.

If $PTSIDL = 1$, the module will stop in Idle mode. If the PWM module is programmed to stop in Idle mode, the operation of the PWM outputs and fault input pins will be the same as the operation in Sleep mode. (See discussion in **Section 15.13.1 “PWM Operation in Sleep mode”**.)

15.14 Special Features for Device Emulation

The PWM module has a special feature to support the debugging environment. All enabled PWM pins can be optionally tri-stated when the hardware emulator or debugger device is halted to examine memory contents. The user should install pull-up or pull-down resistors to ensure the PWM outputs are driven to the correct state when device execution is halted.

When operating in Debug mode, do not disable the PWM module by setting the $PWMMC$ bit in the $PMD1$ register. If the PWM module is disabled and re-enabled by using the $PWMMC$ bit, the reserved bit used by the DSC dsPIC's emulation hardware to tri-state the enabled outputs is reset to zero, which causes the PWM module to continue operation during a halt.

The function of the PWM output pins at a device Reset and the output pin polarity is determined by three device configuration bits (see **Section 15.9 “PWM Output and Polarity Control”**). The hardware debugger or emulation tool provides a method to change the values of these configuration bits. Please refer to the tool's user manual for more information.

15.15 Register Maps

Table 15-8: Registers Associated with the 8-Output PWM Module

| Name | ADR | Bit 15 | Bit 14 | Bit 13 | Bit 12 | Bit 11 | Bit 10 | Bit 9 | Bit 8 | Bit 7 | Bit 6 | Bit 5 | Bit 4 | Bit 3 | Bit 2 | Bit 1 | Bit 0 | Value on Reset |
|---------|------|---------------------------|------------------------------------|--------|--------|-------------|------------|--------|--------|------------|----------------------------|--------|-------------|------------|---------------------|---------------------|---------------------|---------------------|
| INTCON1 | 0080 | NSTDIS | — | — | — | — | — | — | — | — | — | — | — | — | — | — | — | 0000 0000 0000 0000 |
| INTCON2 | 0082 | ALTIVT | — | — | — | — | — | — | — | — | — | — | — | — | — | — | — | 0000 0000 0000 0000 |
| IFS2 | 0088 | — | — | — | FLTBIF | FLTAIF | — | — | — | PWMIF | — | — | — | — | — | — | — | 0000 0000 0000 0000 |
| IEC2 | 0090 | — | — | — | FLTBIE | FLTAIE | — | — | — | PWMIE | — | — | — | — | — | — | — | 0000 0000 0000 0000 |
| IPC9 | 00A6 | — | PWMIP<2:0> | | | — | — | — | — | — | — | — | — | — | — | — | — | 0100 0100 0100 0100 |
| IPC10 | 00A8 | — | FLTAIP<2:0> | | | — | — | — | — | — | — | — | — | — | — | — | — | 0100 0100 0100 0100 |
| IPC11 | 00AA | — | — | — | — | — | — | — | — | — | — | — | — | FLTBIP<2:> | | | 0000 0000 0000 0000 | |
| PTCON | 01C0 | PTEN | — | PTSIDL | — | — | — | — | — | PTOPS<3:0> | | | PTCKPS<1:0> | | PTMOD<1:0> | | 0000 0000 0000 0000 | |
| PTMR | 01C2 | PTDIR | PWM Time Base register | | | | | | | | | | | | | | 0000 0000 0000 0000 | |
| PTPER | 01C4 | — | PWM Time Base Period register | | | | | | | | | | | | | | 0111 1111 1111 1111 | |
| SEVTCMP | 01C6 | SEVTDIR | PWM Special Event Compare register | | | | | | | | | | | | | | 0000 0000 0000 0000 | |
| PWMCON1 | 01C8 | — | — | — | — | PMOD4 | PMOD3 | PMOD2 | PMOD1 | PEN4H | PEN3H | PEN2H | PEN1H | PEN4L | PEN3L | PEN2L | PEN1L | 0000 0000 0000 0000 |
| PWMCON2 | 01CA | — | — | — | — | SEVOPS<3:0> | | | — | — | — | — | — | IUE | OSYNC | UDIS | 0000 0000 0000 0000 | |
| DTCN1 | 01CC | DTBPS<1:0> | Dead Time B Value register | | | | DTAPS<1:0> | | | | Dead Time A Value register | | | | 0000 0000 0000 0000 | | | |
| DTCN2 | 01CE | — | — | — | — | — | — | — | — | DTS4A | DTS4I | DTS3A | DTS3I | DTS2A | DTS2I | DTS1A | DTS1I | 0000 0000 0000 0000 |
| FLTACON | 01D0 | FAOV4H | FAOV4L | FAOV3H | FAOV3L | FAOV2H | FAOV2L | FAOV1H | FAOV1L | FLTAM | — | — | — | FAEN4 | FAEN3 | FAEN2 | FAEN1 | 0000 00-0 0000 0000 |
| FLTBCON | 01D2 | FBOV4H | FBOV4L | FBOV3H | FBOV3L | FBOV2H | FBOV2L | FBOV1H | FBOV1L | FLTBM | — | — | — | FBEN4 | FBEN3 | FBEN2 | FBEN1 | 0000 0000 0000 0000 |
| OVDCON | 01D4 | POVD4H | POVD4L | POVD3H | POVD3L | POVD2H | POVD2L | POVD1H | POVD1L | POUT4H | POUT4L | POUT3H | POUT3L | POUT2H | POUT2L | POUT1H | POUT1L | 1111 1111 00-0 0000 |
| PDC1 | 01D6 | PWM Duty Cycle 1 register | | | | | | | | | | | | | | 0000 0000 0000 0000 | | |
| PDC2 | 01D8 | PWM Duty Cycle 2 register | | | | | | | | | | | | | | 0000 0000 0000 0000 | | |
| PDC3 | 01DA | PWM Duty Cycle 3 register | | | | | | | | | | | | | | 0000 0000 0000 0000 | | |
| PDC4 | 01DC | PWM Duty Cycle 4 register | | | | | | | | | | | | | | 0000 0000 0000 0000 | | |

Note 1: Reset state of PENxx control bits depends on the state of the PWMPIN device configuration bit.
 2: Shaded register and bit locations not implemented for the 6-output MCPWM module.
 3: The IUE bit is not implemented on the dsPIC30F6010 device.

Table 15-9: Registers Associated with the 6-Output PWM Module

| Name | ADR | Bit 15 | Bit 14 | Bit 13 | Bit 12 | Bit 11 | Bit 10 | Bit 9 | Bit 8 | Bit 7 | Bit 6 | Bit 5 | Bit 4 | Bit 3 | Bit 2 | Bit 1 | Bit 0 | Value on Reset |
|----------|------|---------------------------|------------------------------------|--------|--------|--------|--------|--------|--------|------------|-------|----------------------------|-------------|--------|------------|--------|---------------------|---------------------|
| INTCON1 | 0080 | NSTDIS | — | — | — | — | — | — | — | — | — | — | — | — | — | — | — | 0000 0000 0000 0000 |
| INTCON2 | 0082 | ALTIVT | — | — | — | — | — | — | — | — | — | — | — | — | — | — | — | 0000 0000 0000 0000 |
| IFS2 | 0088 | — | — | — | — | FLATIF | — | — | — | PWMIF | — | — | — | — | — | — | — | 0000 0000 0000 0000 |
| IEC2 | 0090 | — | — | — | — | FLTAIE | — | — | — | PWMIE | — | — | — | — | — | — | — | 0000 0000 0000 0000 |
| IPC9 | 00A6 | — | PWMIP<2:0> | | | | — | — | — | — | — | — | — | — | — | — | — | 0100 0100 0100 0100 |
| IPC10 | 00A8 | — | FLTAIP<2:0> | | | | — | — | — | — | — | — | — | — | — | — | — | 0100 0100 0100 0100 |
| PTCON | 01C0 | PTEN | — | PTSIDL | — | — | — | — | — | PTOPS<3:0> | | | PTCKPS<1:0> | | PTMOD<1:0> | | 0000 0000 0000 0000 | |
| PTMR | 01C2 | PTDIR | PWM Time Base register | | | | | | | | | | | | | | | 0000 0000 0000 0000 |
| PTPER | 01C4 | — | PWM Time Base Period register | | | | | | | | | | | | | | | 0111 1111 1111 1111 |
| SEVTCMP | 01C6 | SEVTDIR | PWM Special Event Compare register | | | | | | | | | | | | | | | 0000 0000 0000 0000 |
| PWMCON1 | 01C8 | — | — | — | — | — | PMOD3 | PMOD2 | PMOD1 | — | PEN3H | PEN2H | PEN1H | — | PEN3L | PEN2L | PEN1L | 0000 0000 0000 0000 |
| PWMCON2 | 01CA | — | — | — | — | — | — | — | — | — | — | — | — | — | IUE | OSYNC | UDIS | 0000 0000 0000 0000 |
| DTCON1 | 01CC | — | — | — | — | — | — | — | — | DTAPS<1:0> | | Dead Time A Value register | | | | | 0000 0000 0000 0000 | |
| Reserved | 01CE | — | — | — | — | — | — | — | — | — | — | — | — | — | — | — | — | — |
| FLTACON | 01D0 | — | — | FAOV3H | FAOV3L | FAOV2H | FAOV2L | FAOV1H | FAOV1L | FLTAM | — | — | — | FAEN4 | FAEN3 | FAEN2 | FAEN1 | 0000 00-0 0000 0000 |
| Reserved | 01D2 | — | — | — | — | — | — | — | — | — | — | — | — | — | — | — | — | — |
| OVDCON | 01D4 | — | — | POVD3H | POVD3L | POVD2H | POVD2L | POVD1H | POVD1L | — | — | POUT3H | POUT3L | POUT2H | POUT2L | POUT1H | POUT1L | 1111 1111 00-0 0000 |
| PDC1 | 01D6 | PWM Duty Cycle 1 register | | | | | | | | | | | | | | | 0000 0000 0000 0000 | |
| PDC2 | 01D8 | PWM Duty Cycle 2 register | | | | | | | | | | | | | | | 0000 0000 0000 0000 | |
| PDC3 | 01DA | PWM Duty Cycle 3 register | | | | | | | | | | | | | | | 0000 0000 0000 0000 | |

- Note** 1: Reset state of PENxx control bits depends on the state of the PWMPIN device configuration bit.
2: Shaded register and bit locations not implemented for the 6-output MCPWM module.
3: The IUE bit is not implemented on the dsPIC30F6010 device.

15.16 Related Application Notes

This section lists application notes that are related to this section of the manual. These application notes may not be written specifically for the dsPIC30F Product Family, but the concepts are pertinent, and could be used with modification and possible limitations. The current application notes related to the MCPWM module are:

| Title | Application Note # |
|--|---------------------------|
| PIC18CXXX/PIC16CXXX Servomotor | AN696 |
| Using the dsPIC30F for Sensorless BLDC Control | AN901 |
| Using the dsPIC30F for Vector Control of an ACIM | AN908 |
| Sensored BLDC Motor Control Using dsPIC30F2010 | AN957 |
| An Introduction to AC Induction Motor Control Using the dsPIC30F MCU | AN984 |

| |
|---|
| Note: Please visit the Microchip web site at www.microchip.com for additional Application Notes and code examples for the dsPIC30F Family of devices. |
|---|

15.17 Revision History

Revision A

This is the initial released revision of this document.

Revision B

This revision provides expanded information for the dsPIC30F MCPWM module.

Revision C

This revision incorporates all known errata at the time of this document update.

Revision D

This revision includes the Immediate Update Enable Capability (IUE) bit.

Revision E

This revision includes the following updates:

- Clarification of operation in Debug mode (see **15.12 “PWM Special Event Trigger”**)
- Clarification of the SEVTDIR control bit function (see **15.14 “Special Features for Device Emulation”**)
- Clarification of Free Running and Up/Down Counting PWM modes:
 - **Table 15-2: “Example PWM Frequencies and Resolutions, 1:1 Prescaler, Free Running Count Mode PWM and No Dead Time”**,
 - **Table 15-3: “Example PWM Frequencies and Resolutions, 1:1 Prescaler, Up/Down Counting Mode PWM and No Dead Time”**
 - **Equation 15-4: “Duty Cycle Calculation for Free Running and Up/Down Counting Modes”**
- Minor corrections to the document text

NOTES: