

DISPLAY ELEKTRONIK GMBH

DATA SHEET

LCD MODULE

DEM 40491 SYH-LY

Product specification

VERSION: 4

09.04.2003

GENERAL SPECIFICATION

MODULE NO. :

DEM 40491 SYH-LY

CUSTOMER P / N

VERSION NO.	CHANGE DESCRIPTION	DATE
0	ORIGINAL VERSION	2001/02/08
1	CHANGE FUNCTION	2001/02/22
2	CHANGE PIN ASSIGNMENT	2001/02/26
3	CHANGE DDRAM	2001/02/27
4	ADD A/K CONTACT HOLES	2001/03/29

PREPARED BY: ZJK DATE: 29.03.2001

APPROVED BY: MH DATE: 09.04.2003

CONTENTS

1. FUNCTIONS & FEATURES -----	2
2. MECHANICAL SPECIFICATIONS -----	2
3. BLOCK DIAGRAM -----	2
4. EXTERNAL DIMENSIONS -----	3
5. PIN ASSIGNMENT -----	3
6.1 PCB DRAWING AND DESCRIPTION-----	4
6.2 EXAMPLE APPLICATION-----	5
6.3 THE MODULE NO. IS PRINTED ON THE PCB-----	5
7. BACKLIGHT & SWITCH (Ta = -20 ~ +75°C)-----	6
8. DISPLAY DATA RAM (DRAM)-----	6
9. MAXIMUM ABSOLUTE LIMIT-----	7
10. ELECTRICAL CHARACTERISTICS -----	7
10-1 DC CHARACTERISTICS-----	7
10-2 AC CHARACTERISTICS-----	8
10-2-1 WRITE MODE-----	8
10-2-2 READ MODE-----	9
11.CONTROL AND DISPLAY COMMAND-----	10
12.STANDARD CHARACTER PATTERN -----	11
13.LCM INITIALIZING BY INSTRUCTION-----	12
13-1 8 bit INTERFACE MODE-----	12
13-2 4 bit INTERFACE MODE-----	13
14. LCD MODULES HANDLING PRECAUTIONS-----	14
15. OTHERS -----	15

1.FUNCTIONS & FEATURES

- DEM 40491-Series LCD type:

MODULE	LCD MODEL	LCD TYPE
DEM 40491 SYH-LY	STN, yellow-green	Transflective Positive mode

- Viewing Direction : 6 O'clock
- Driving Scheme : 1/16 Duty Cycle, 1/5 Bias
- Power Supply Voltage : 2.7V to 5.5V (typ. 5V)
- Backlight Color : Yellow Green (lightbox)
- V_{LCD} Adjustable for Best Contrast : 4.5V (typ.)
- Display Format : 40 x 4 Characters (5 x 8 dots, Format : 208 Kinds)
- Internal Memory : CGROM (10,080 bits)
: CGRAM (64 x 8 bits)
: DDRAM (80 x 8 bits for Digits)
- Interface : Easy Interface with a 4 - bit or 8 - bit MPU

2.MECHANICAL SPECIFICATIONS

- Character Pitch : 3.53(w) x 6.09(h) (mm)
- Character Size : 2.78(w) x 4.89(h) (mm)
- Character Font : 5 x 8dots
- Dot Size : 0.50(w) x 0.55(h) (mm)
- Dot Pitch : 0.57(w) x 0.62(h) (mm)

3.BLOCK Diagram

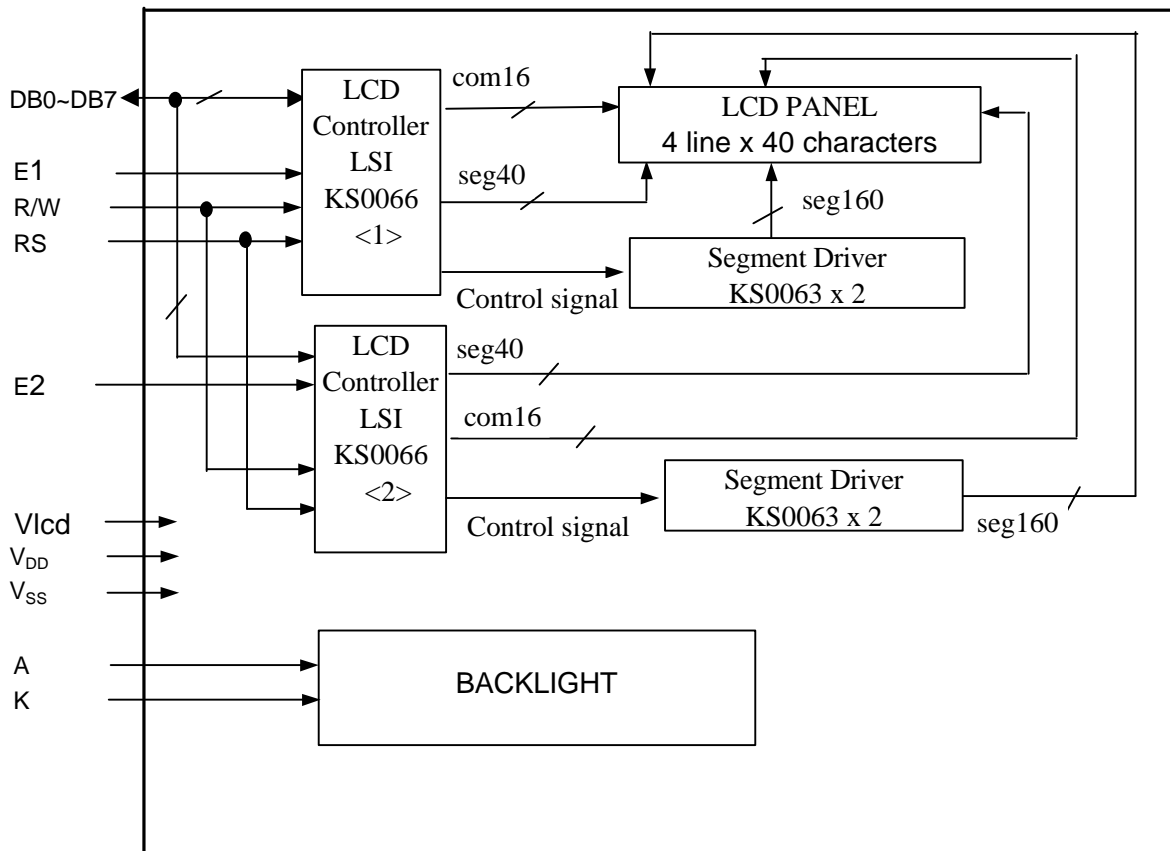

Figure 1.0

4.External Dimensions

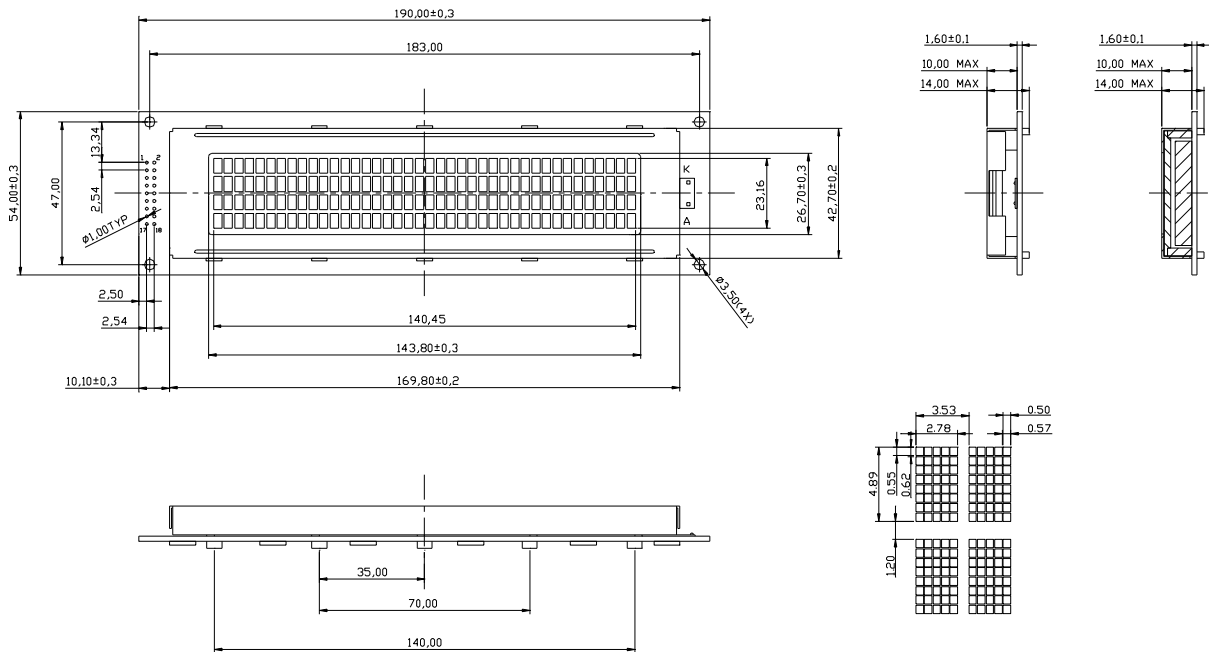
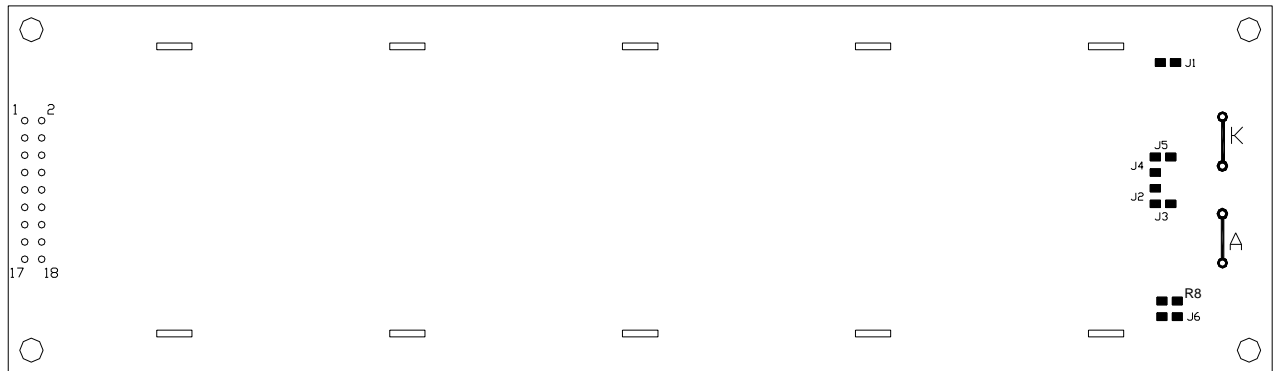

Figure 2.0

5.PIN Assignment

Pin No.	Symbol	Function
1	DB7	Display Data Signal
2	DB6	
3	DB5	
4	DB4	
5	DB3	
6	DB2	
7	DB1	
8	DB0	
9	E1	Read/Write Enable Signal of first KS0066
10	R/W	Read or Write Select Signal
11	RS	Select Display Data("H") or Instructions("L")
12	V0	Power Supply for LCD
13	Vss	Ground
14	VDD	Power supply
15	E2	Read/Write Enable Signal of second KS0066
16	NC	NO Connect
17	LED- (K)	Cathode of Backlight
18	LED+ (A)	Anode of Backlight

6.1 PCB DRAWING AND DESCRIPTION



Description :

6-1-1.The polarity of the pin 17 and the pin 18

Symbol	Symbol State	J3,J5	J2,J4	LED Polarity	
				17 Pin	18 Pin
J2,J4	Solder- Bridge	Open	————	Anode	Cathode
J3,J5	Solder- Bridge	————	Open	Cathode	Anode

6-1-2. The metal-bezel should be on ground when the J1 is Solder- Bridge .

6-1-3. The LED Resistor should be bridged when the J6 is Solder-Bridge .

6-1-4. The R8 and J6 are the LED Resistor. (R8=J6=8,2 Ohm).

6.2 Example application

6-2-1 The LED resistor should be bridged as following .

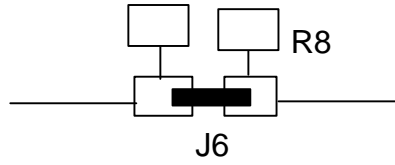

6-2-2 The 17 pin is the Anode and the 18 pin is the cathode as following .



6-2-3 The 17 pin is the cathode and the 18 pin is the Anode as following .

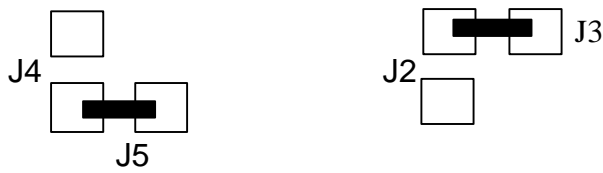

6-2-4 The metal-bezel is on ground as following .



6.3 The module No. is printed on the PCB .

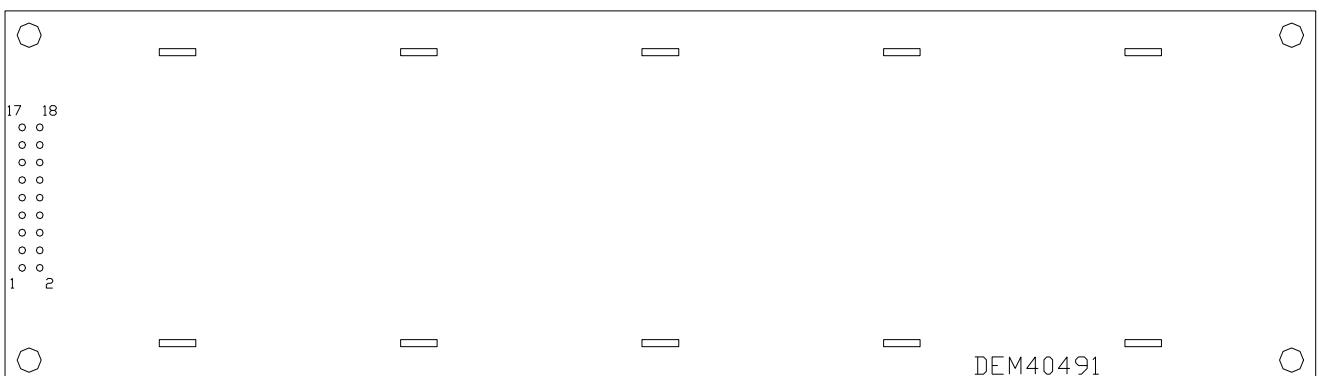

Figure 4.0

7. BACKLIGHT & SWITCH (Ta = -20 ~ +75°C)

Item	Symbol	Standard Value	unit	Applicable teminal
Backlight Voltage	V	5.0	V	LED+ / LED-
Backlight Current	I	~194	mA	

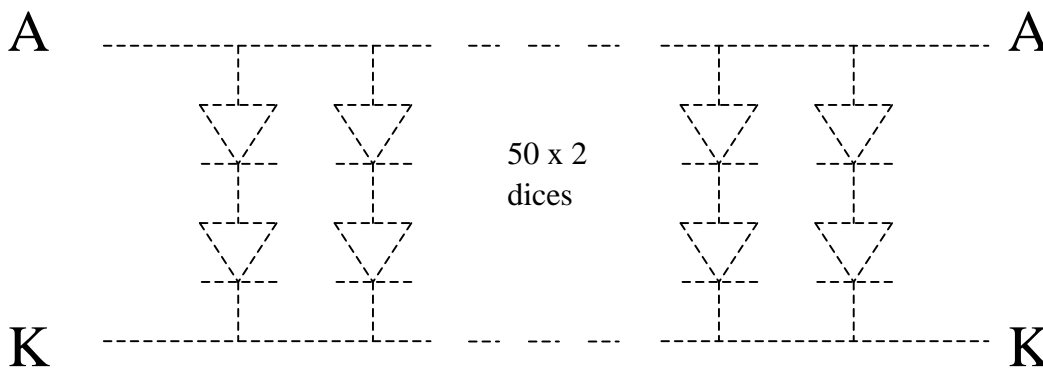

Figure 5.0

8. DISPLAY DATA RAM (DDRAM)

	1	2	3	4	5	6	7	8	9	10	11	12	13	-----	33	34	35	36	37	38	39	40	←DISPLAY POSITION
FIRST LINE	00	01	02	03	04	05	06	07	08	09	0A	0B	0C	-----	20	21	22	23	24	25	26	27	←DD RAM ADDRESS
SECOND LINE	40	41	42	43	44	45	46	47	48	49	4A	4B	4C	-----	60	61	62	63	64	65	66	67	

*First + Second Line Control by Enable 1, Third + Fourth Line Control by Enable 2 .

9. MAXIMUM ABSOLUTE LIMIT

Item	Symbol	Standard value	Unit
Power supply voltage(1)	V_{DD}	-0.3 ~ +7.0	V
Power supply voltage(2)	V_{LCD}	$V_{DD}-13.5 \sim V_{DD}+0.3$	V
Input voltage	V_{IN}	-0.3 ~ $V_{DD}+0.3$	V
Volt. For BL	V_{LED1}	4 ~ 4.5	V
Operating temperature	T_{opr}	-20 ~ +70	°C
Storage temperature	T_{stg}	-30 ~ +80	°C

*Voltage greater than above may damage to the Circuit.

$$V_{DD} > V_1 > V_2 > V_3 > V_4 > V_5$$

10. Electrical Characteristics

10-1 DC Characteristics ($V_{DD} = 4.5V \sim 5.5V$, $T_a = -20 \sim +75^\circ C$)

Item	Symbol	Standard Value			Test Condition	Unit
		MIN	TYP	MAX		
Operating Voltage	V_{DD}	4,5	5	5,5	—	V
Supply Current	I_{DD}	—	0,35	0,6	$V_{DD}=5V, f_{osc}=270kHz$	mA
Input Voltage(1) (except OSC1)	V_{IL1}	-0,3	—	0,6	—	V
	V_{IH1}	2,2	—	V_{DD}	—	
Input Voltage(2) (OSC1)	V_{IL2}	-0,2	—	1.0	—	V
	V_{IH2}	$V_{DD}-1.0$	—	V_{DD}	—	
Output Voltage (1) (DB0 TO DB7)	V_{OL1}	—	—	0,4	$I_{OL}=1.2mA$	V
	V_{OH1}	2,4	—	—	$I_{OH}=-0.205mA$	
Output Voltage (2) (except DB0 TO DB7)	V_{OL2}	—	—	$0.1V_{DD}$	$I_{OL}=40uA$	V
	V_{OH2}	$0.9V_{DD}$	—	—	$I_{OH}=-40uA$	
Voltage Drop	V_{dCOM}	—	—	1	$I_O=0.1\pm mA$	V
	V_{dSEG}	—	—	1		
Input Leakage Current	I_{IKG}	-1	—	1	$V_{IN}=0V$ to V_{DD}	uA
Input Low Current	I_{IL}	-50	-125	-250	$V_{IN}=0V, V_{DD}=5V$ (pull up)	uA
Internal Clock (external Rf)	f_{OSC1}	190	270	350	$R_f = 91k \pm 2\%$ ($V_{DD}=5V$)	kHz
External Clock	f_{OSC}	125	270	410	—	kHz
	duty	45	50	55	—	°C
	t_R, t_F	—	—	0,2	—	us
LCD Driving Voltage	V_{LCD}	3.0	—	13.0	$V_{DD}-V_5(1/5, 1/4$ Bias)	V

10-2 AC Characteristics ($V_{DD} = 4.5V \sim 5.5V$, $T_a = -20 \sim +75^{\circ}C$)

10-2-1. Write mode (writing data from MPU to DEM 40491-Series)

Characteristic	Symbol	Min	Typ	Max	Unit	Test PIN
E Cycle Time	t_C	500	—	—	ns	E
E Rise Time	t_R	—	—	20	ns	E
E Fall Time	t_F	—	—	20	ns	E
E Pulse width (High,Low)	t_W	230	—	—	ns	E
R/W and RS Set-up Time	t_{SU1}	40	—	—	ns	R/W,RS
R/W and RS Hold Time	t_{H1}	10	—	—	ns	R/W,RS
Data Set-up Time	t_{SU2}	80	—	—	ns	DB0~DB7
Data Hold Time	t_{H2}	10	—	—	ns	DB0~DB7

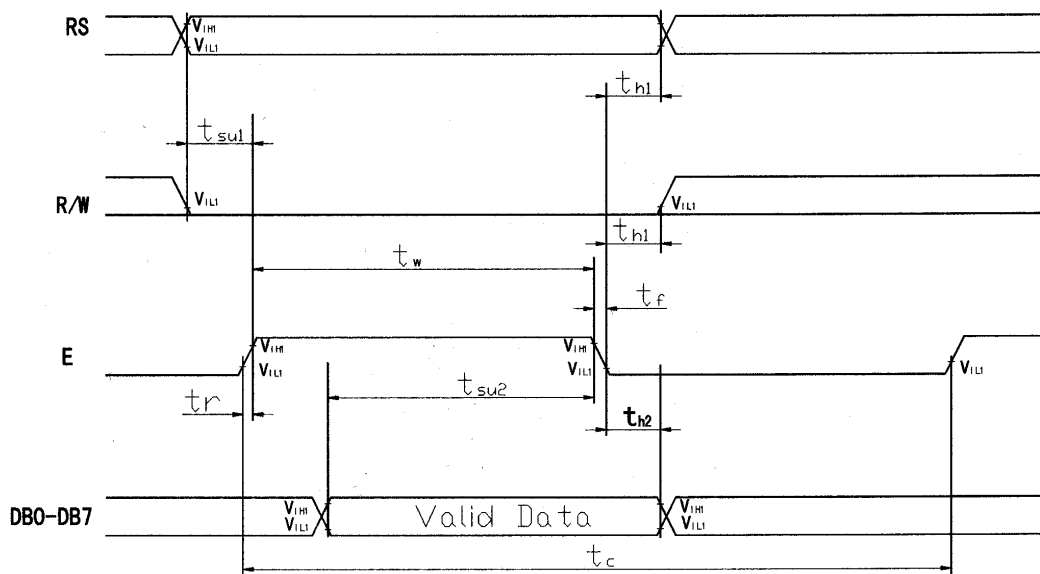

10-2-2. Read mode (Reading data from DEM 40491-Series to MPU)

Characteristic	Symbol	Min	Typ	Max	Unit	Test PIN
E Cycle Time	t_c	500	—	—	ns	E
E Rise Time	t_R	—	—	20	ns	E
E Fall Time	t_F	—	—	20	ns	E
E Pulse width (High , Low)	t_w	230	—	—	ns	E
R/W and RS Set-up Time	t_{SU}	40	—	—	ns	R/W,RS
R/W and RS Hold Time	t_H	10	—	—	ns	R/W,RS
Data output Delay Time	t_D	—	—	120	ns	DB0~DB7
Data Hold Time	t_{DH}	5	—	—	ns	DB0~DB7

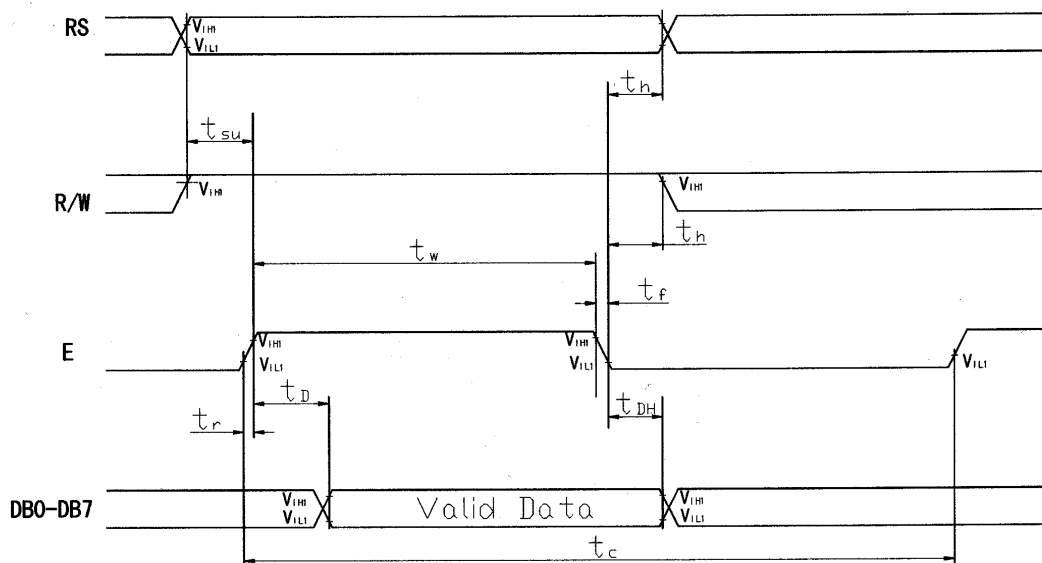

11. CONTROL AND DISPLAY COMMAND

Command	RS	R/W	DB7	DB6	DB5	DB4	DB3	DB2	DB1	DB0	Execution time (fosc=270KHz)	Remark																		
clear Display	L	L	L	L	L	L	L	L	L	H	1.53ms																			
Return home	L	L	L	L	L	L	L	L	H	X	1.53ms	Cursor move to first digit																		
Entry mode set	L	L	L	L	L	L	L	H	I/D	SH	39us	I/D:set cursor move direction <table border="1"> <tr> <td>I/D</td> <td>H</td> <td>Increase</td> </tr> <tr> <td></td> <td>L</td> <td>Decrease</td> </tr> </table> SH:Specifies shift of display SH <table border="1"> <tr> <td>H</td> <td>Display is shifted</td> </tr> <tr> <td>L</td> <td>Display is not shifted</td> </tr> </table>	I/D	H	Increase		L	Decrease	H	Display is shifted	L	Display is not shifted								
I/D	H	Increase																												
	L	Decrease																												
H	Display is shifted																													
L	Display is not shifted																													
Display on/off control	L	L	L	L	L	L	H	D	C	B	39us	Display <table border="1"> <tr> <td>D</td> <td>H</td> <td>Display on</td> </tr> <tr> <td></td> <td>L</td> <td>Display off</td> </tr> </table> Cursor <table border="1"> <tr> <td>C</td> <td>H</td> <td>Cursor on</td> </tr> <tr> <td></td> <td>L</td> <td>Cursor off</td> </tr> </table> Blinking <table border="1"> <tr> <td>B</td> <td>H</td> <td>Blinking on</td> </tr> <tr> <td></td> <td>L</td> <td>Blinking off</td> </tr> </table>	D	H	Display on		L	Display off	C	H	Cursor on		L	Cursor off	B	H	Blinking on		L	Blinking off
D	H	Display on																												
	L	Display off																												
C	H	Cursor on																												
	L	Cursor off																												
B	H	Blinking on																												
	L	Blinking off																												
Cursor or Display Shift	L	L	L	L	L	H	S/C	R/L	X	X	39us	<table border="1"> <tr> <td>SC</td> <td>H</td> <td>Display shift</td> </tr> <tr> <td></td> <td>L</td> <td>Cursor move</td> </tr> <tr> <td>R/L</td> <td>H</td> <td>Right shift</td> </tr> <tr> <td></td> <td>L</td> <td>Left shift</td> </tr> </table>	SC	H	Display shift		L	Cursor move	R/L	H	Right shift		L	Left shift						
SC	H	Display shift																												
	L	Cursor move																												
R/L	H	Right shift																												
	L	Left shift																												
function Set	L	L	L	L	H	DL	N	F	X	X	39us	<table border="1"> <tr> <td>DL</td> <td>H</td> <td>8bits interface</td> </tr> <tr> <td></td> <td>L</td> <td>4bits interface</td> </tr> <tr> <td>N</td> <td>H</td> <td>2 line display</td> </tr> <tr> <td></td> <td>L</td> <td>1 line display</td> </tr> <tr> <td>F</td> <td>H</td> <td>Display on</td> </tr> <tr> <td></td> <td>L</td> <td>Display off</td> </tr> </table>	DL	H	8bits interface		L	4bits interface	N	H	2 line display		L	1 line display	F	H	Display on		L	Display off
DL	H	8bits interface																												
	L	4bits interface																												
N	H	2 line display																												
	L	1 line display																												
F	H	Display on																												
	L	Display off																												
Set CGRAM address	L	L	L	H	AC5	AC4	AC3	AC2	AC1	AC0	39us	CGRAM data is sent and received after this setting																		
Set DDRAM address	L	L	H	AC6	AC5	AC4	AC3	AC2	AC1	AC0	39us	DDRAM data is sent and received after this setting																		
Read busy flag& address	L	H	BF	AC6	AC5	AC4	AC3	AC2	AC1	AC0	0us	<table border="1"> <tr> <td>BF</td> <td>H</td> <td>Busy</td> </tr> <tr> <td></td> <td>L</td> <td>Ready</td> </tr> </table> -Reads BF indication internal operating is being performed -Reads address counter contents	BF	H	Busy		L	Ready												
BF	H	Busy																												
	L	Ready																												
Write data to RAM	H	L	D7	D6	D5	D4	D3	D2	D1	D0	43us	Write data into DDRAM or CGRAM																		
Read data from RAM	H	H	D7	D6	D5	D4	D3	D2	D1	D0	43us	Read data from DDRAM or CGRAM																		

*X:Don't care

12 STANDARD CHARACTER PATTERN

Upper(Rx) Lower(Rx)		LLLL	LLLH	LLHL	LLHH	LHLL	LHLH	LHHL	LHHH	HLLL	HLLH	HLHL	HLHH	HHLL	HHLH	HHHL	HHHH
LLLL	CG RAM (1)																
LLLH	(2)																
LLHL	(3)																
LLHH	(4)																
LHLL	(5)																
LHLH	(6)																
LHHL	(7)																
LHHH	(8)																
HLLL	(1)																
HLLH	(2)																
HLHL	(3)																
HLHH	(4)																
HHLL	(5)																
HHLH	(6)																
HHHL	(7)																
HHHH	(8)																

13. LCM INITIALIZING BY INSTRUCTION

13-1 8-bit interface mode

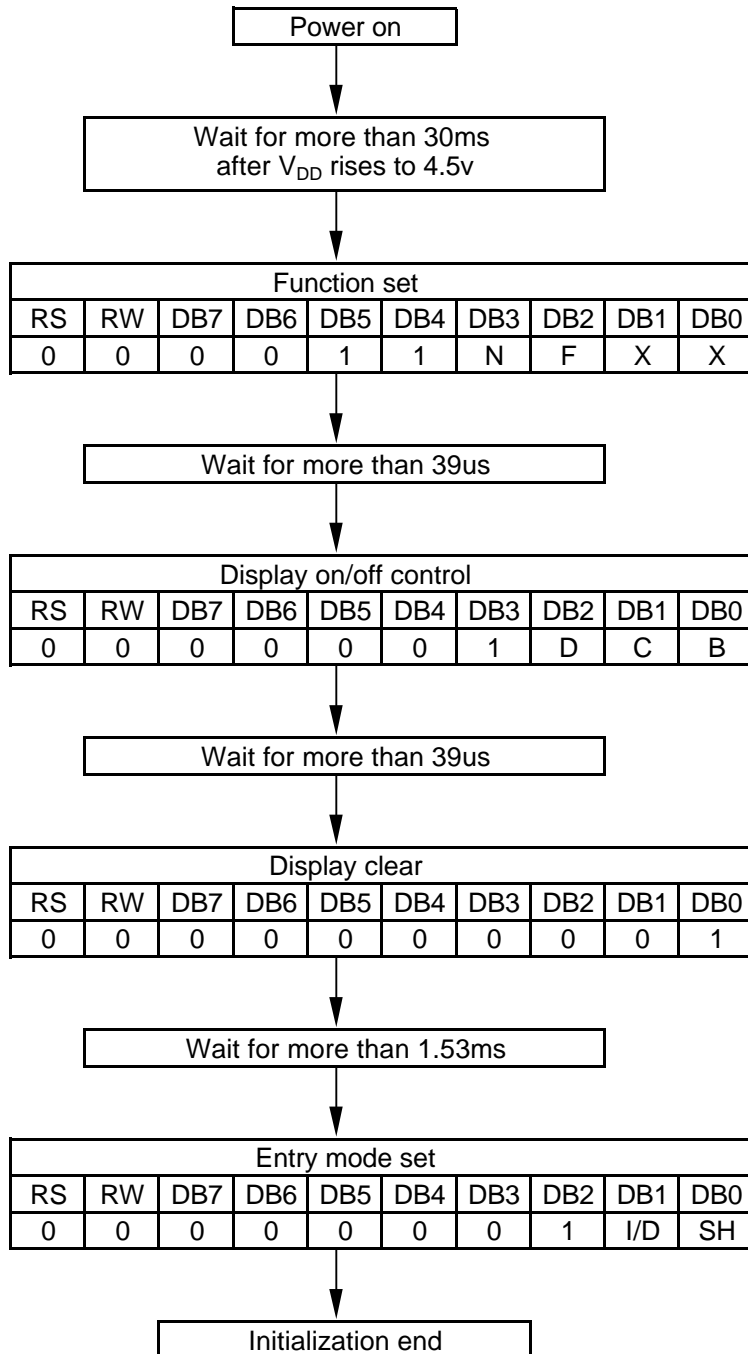

Condition : fosc=270khz

N	0	1-line mode
	1	2-line mode

F	0	display off
	1	display on

D	0	display off
	1	display on

C	0	cursor off
	1	cursor on

B	0	blink off
	1	blink on

I/D	0	decrement mode
	1	increment mode

SH	0	entire shift off
	1	entire shift on

13-2 4-bit interface mode

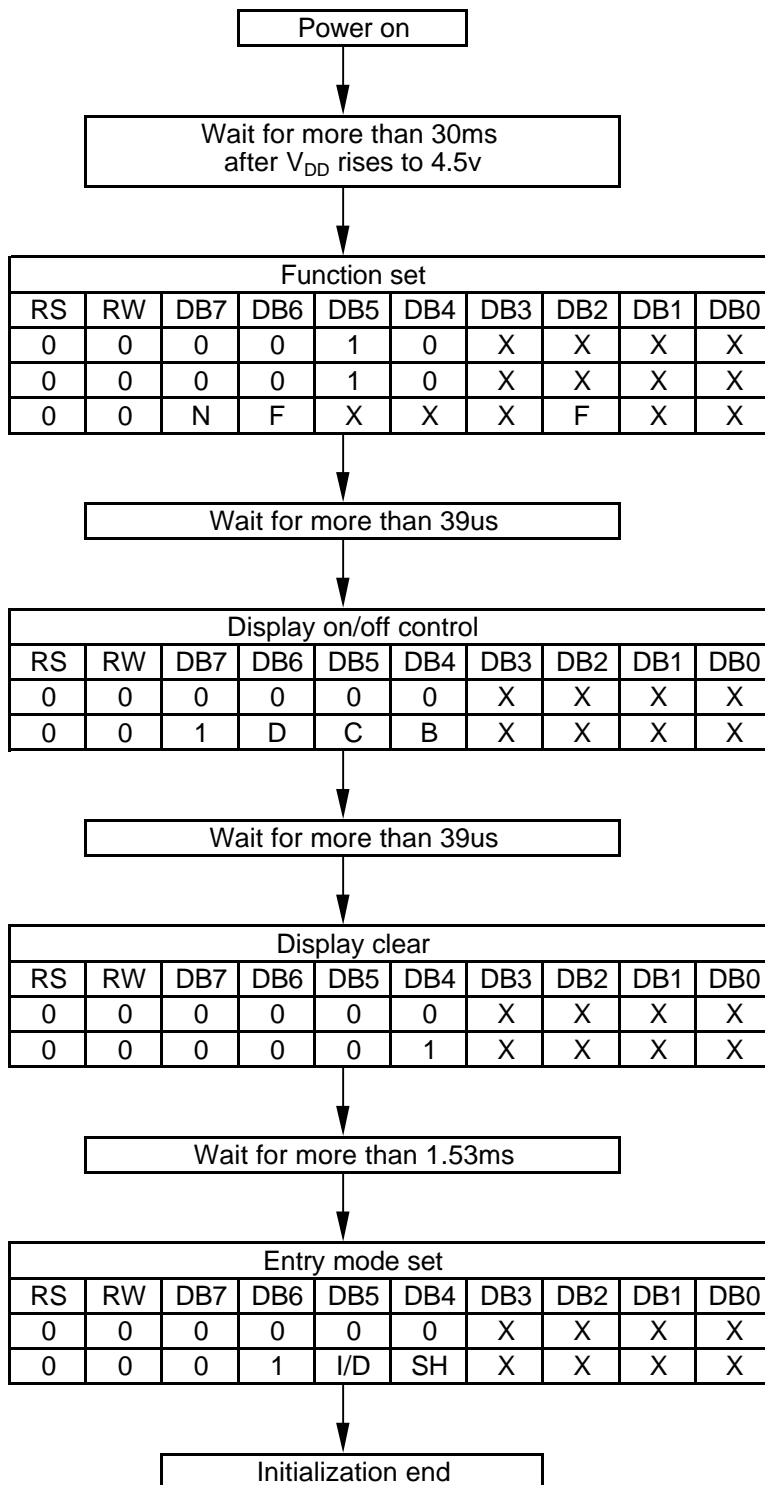

Condition : fosc=270khz

N	0	1-line mode
	1	2-line mode

F	0	display off
	1	display on

D	0	display off
	1	display on

C	0	cursor off
	1	cursor on

B	0	blink off
	1	blink on

I/D	0	decrement mode
	1	increment mode

SH	0	entire shift off
	1	entire shift on

14. LCD Modules Handling precautions

- The display panel is made of glass. Do not subject it to a mechanical shock by dropping it from a high place ,etc.
- If the display panel is damaged and the liquid crystal substance inside it leaks out , do not get any in your mouth . If the substance come into contact with your skin or clothes promptly wash it off using soap and water.

- Do not apply excessive force to the display surface or the adjoining areas since this may cause the color tone to vary.

- The polarizer covering the display surface of the LCD module is soft and easily scratched. handle this polarize carefully

- To prevent destruction of the elements by static electricity , be careful to maintain an optimum work environment.
 - Be sure to ground the body when handling the LCD Modules.
 - Tools required for assembly, such as soldering irons, must be properly grounded.
 - To reduce the amount of static electricity generated, do not conduct assembly and other work under dry conditions.
 - The LCD Module is coated with a film to protect the display surface. Exercise care when peeling off this protective film since static electricity may be generated.

- Storage Precautions
When storing the LCD Modules, avoid exposure to direct sunlight or to the light of fluorescent lamps. Keep the modules in bags designed to prevent static electricity charging under low temperature / normal humidity conditions (avoid high temperature / high humidity and low temperatures below 0°C).Whenever possible, the LCD Modules should be stored in the same conditions in which they were shipped from our company.

15. Others

- Liquid crystals solidify at low temperature (below the storage temperature range) leading to defective orientation of liquid crystal or the generation of air bubbles (black or white). Air bubbles may also be generated if the module is subjected to a strong shock at a low temperature.
- If the LCD Modules have been operating for a long time showing the same display patterns the display patterns may remain on the screen as ghost images and a slight contrast irregularity may also appear. Abnormal operating status can be resumed to be normal condition by suspending use for some time.
It should be noted that this phenomena does not adversely affect performance reliability.
- To minimize the performance degradation of the LCD Modules resulting from caused by static electricity , etc . Exercise care to avoid holding the following sections when handling the modules:
 - Exposed area of the printed circuit board
 - Terminal electrode sections