

SECONDARY REGULATOR FOR VTR ELECTRIC EQUIPMENT 【1】 (VTR 及び 電子機器用)

| Family シリーズ名 | Constitution 構成 | Maximum Rating 最大定格 | | | Type No 機種 | Output1 | | | Output2 | | |
|-----------------|--------------------|------------------------|--------|------------------|---------------|---------|-----|------|---------|-----|-----|
| | | Vin(DC) | Tc max | Tstg | | Vo | Io | | Vo | Io | |
| | | | | | | | Av | Pk | | Av | Pk |
| | | max V | °C | °C | | V | A | A | V | A | A |
| STK 5330 | Series Reg. + SW | 30 | 105 | -30 ~ +105 | STK 5331 | 12.30 | 1.0 | 2.0 | 6.05 | 1.0 | 2.0 |
| STK 5335 | Series Reg. + SW | 30 | 105 | | STK 5335 | 12.30 | 1.0 | 2.0 | 6.10 | 1.0 | 2.0 |
| | | 30 | 105 | | STK 5336 | 12.35 | 1.0 | 2.0 | 6.15 | 1.0 | 2.0 |
| STK 5460 | Series Reg. × 3 | 30 | 105 | | STK 5461 | 12.00 | 1.0 | 2.0 | 12.00 | 1.0 | 2.0 |
| | | 30 | 105 | | STK 5462 | 16.00 | 1.0 | 2.0 | 9.00 | 1.0 | 2.0 |
| | | 30 | 105 | | STK 5466 | 12.00 | 1.0 | 2.0 | 12.00 | 1.0 | 2.0 |
| STK 5470 | Series Reg. × 3 | 30 | 105 | | STK 5471 | 12.00 | 1.5 | 2.5 | 12.00 | 1.5 | 2.5 |
| | | 30 | 105 | | STK 5476 | 12.00 | 1.5 | 2.5 | 12.00 | 1.5 | 2.5 |
| | | 30 | 105 | | STK 5477 | 12.00 | 1.0 | 2.5 | 12.00 | 1.0 | 2.5 |
| STK 5480 | Series Reg. × 4 | 30 | 105 | | STK 5481 | 12.00 | 1.5 | 2.5 | 12.20 | 1.0 | 1.2 |
| | | 30 | 105 | STK 5482 | 15.00 | 1.0 | 2.5 | 5.80 | 0.5 | 1.0 | |
| | | | | 13.00 | | | | | | | |

■ EQUIVALENT CIRCUIT

(2)

■ FEATURES

- 3 or 4 Outputs/Package
- Low sat type(Hi efficiency)
- High-precision setting of output voltage
- With cut off function

■ 特長

- 3又は、4出力/パッケージ
- ローサットタイプ(高効率)
- 出力電圧の高精度設定
- カットオフ機能付

| Output3 | | | Output4 | | | Equivalent Circuit 等価回路 | Applica- tion 応用回路 | Package 外形図 |
|---------|-----|-----|---------|-----|-----|-------------------------------|--------------------------|----------------|
| Vo | Io | | Vo | Io | | | | |
| | Av | Pk | | Av | Pk | | | |
| V | A | A | V | A | A | | | |
| 5.10 | 0.5 | | | | | (1) | (1) | (1) |
| 5.10 | 1.0 | 1.5 | 5.1 | 1.0 | 1.5 | (2) | (2) | (2) |
| | | 1.5 | | | | (3) | (3) | (2) |
| 5.1 | 0.5 | | | | | (4) | (4) | (3) |
| 5.1 | 0.5 | | | | | (4) | (5) | (4) |
| 5.3 | 1.0 | 2.0 | | | | (5) | (6) | (3) |
| 5.3 | 0.5 | | | | | (6) | (7) | (2) |
| 5.3 | 1.0 | 2.0 | | | | (7) | (8) | (5) |
| 5.1 | 1.0 | 2.0 | | | | (8) | (9) | (5) |
| 12.1 | 1.0 | 1.2 | 5.3 | 1.0 | 1.2 | (9) | (10) | (6) |
| 12.0 | 1.0 | 2.5 | 5.1 | 1.0 | 2.5 | (10) | (11) | (7) |

(3)

■ APPLICATION

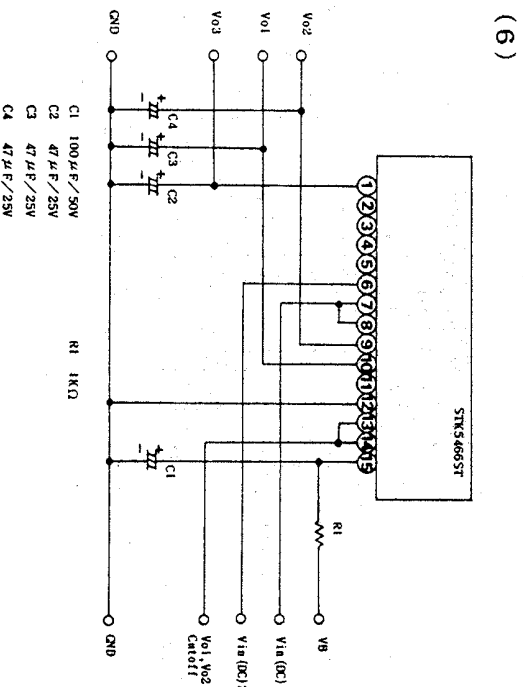
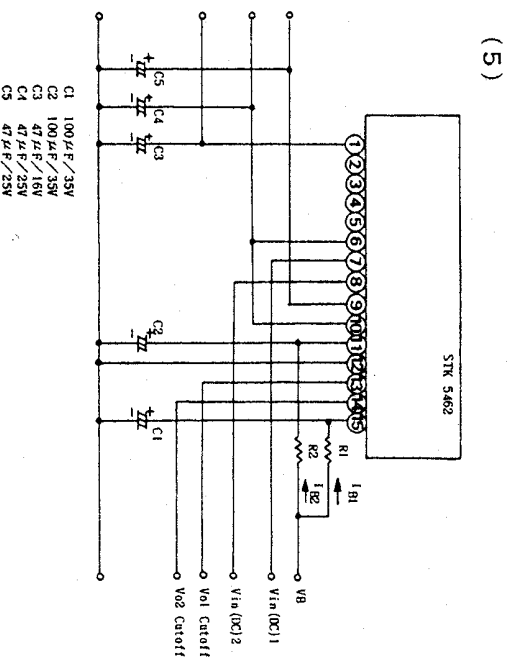
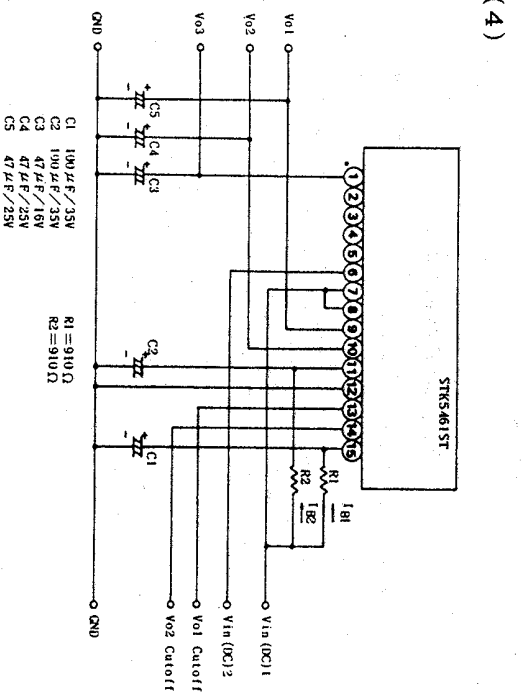
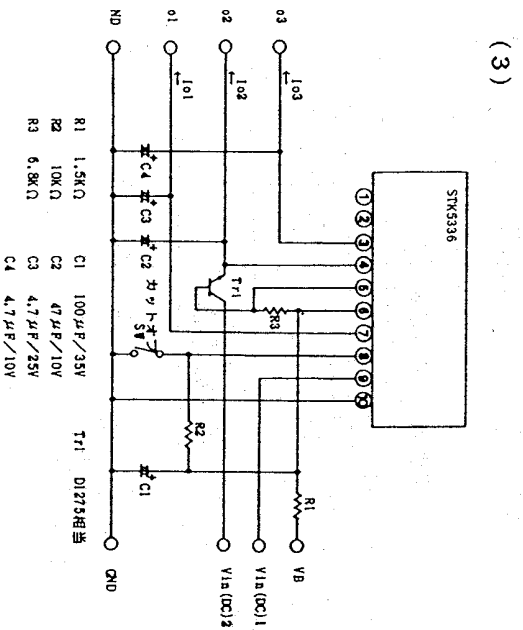
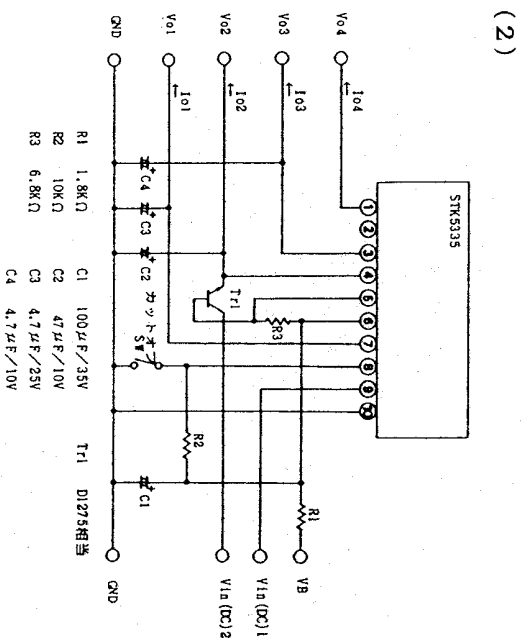
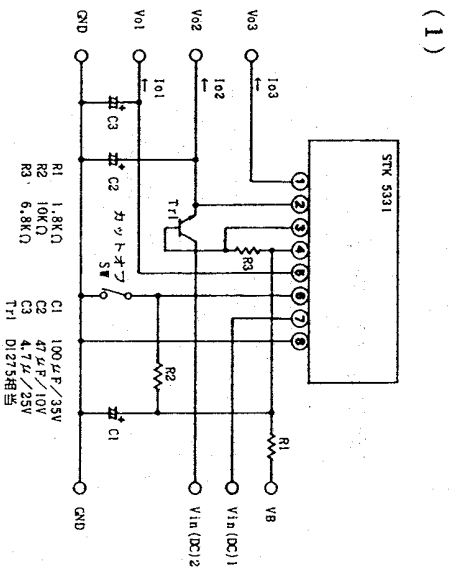

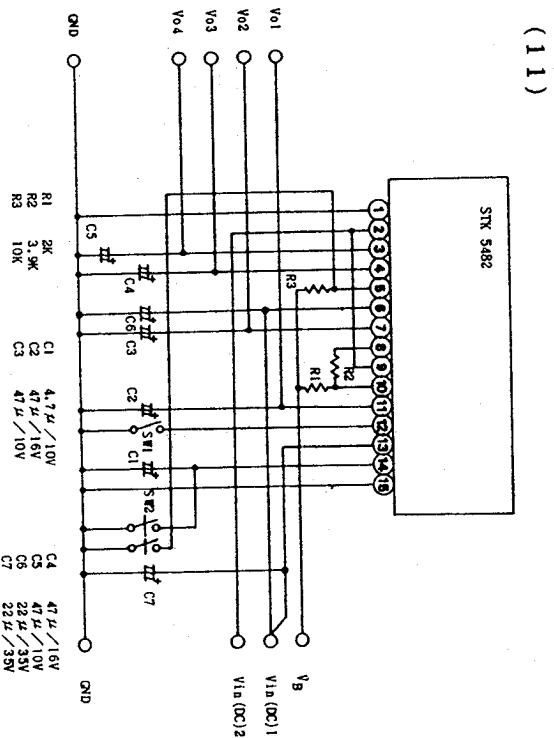
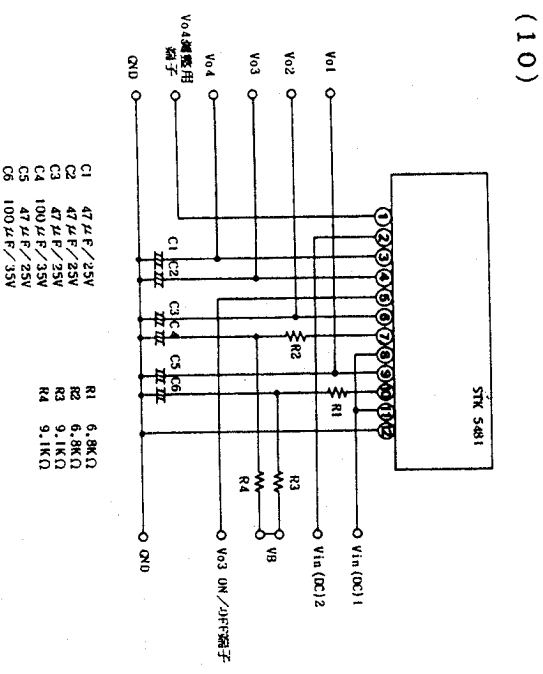
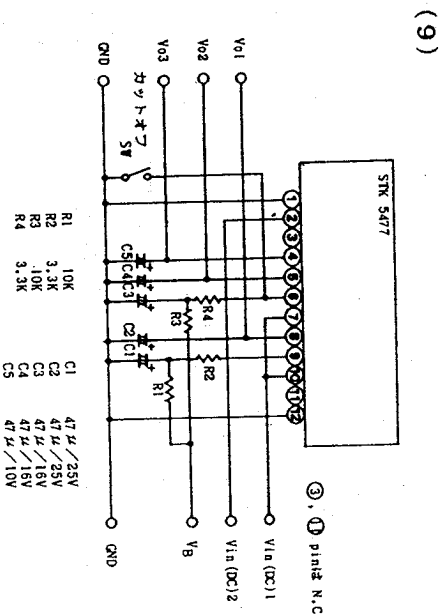
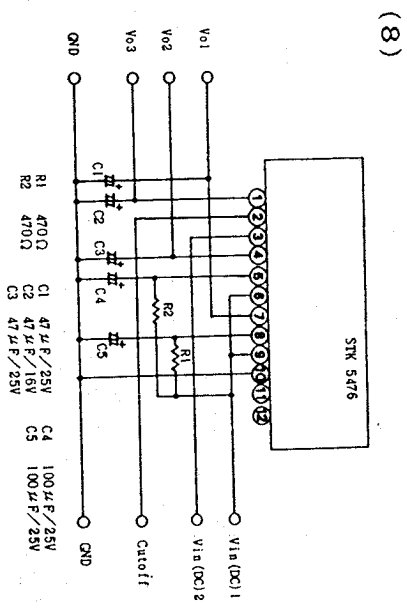
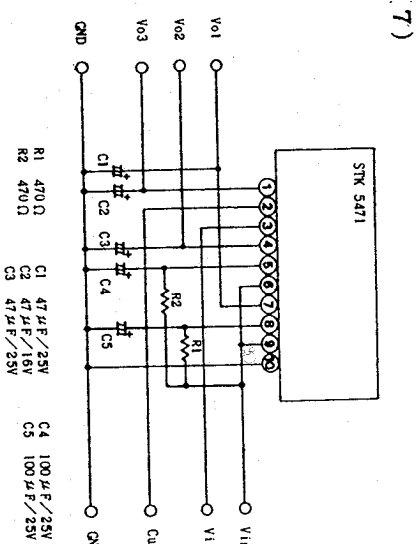

■ PACKAGE DIMENSION

(1)

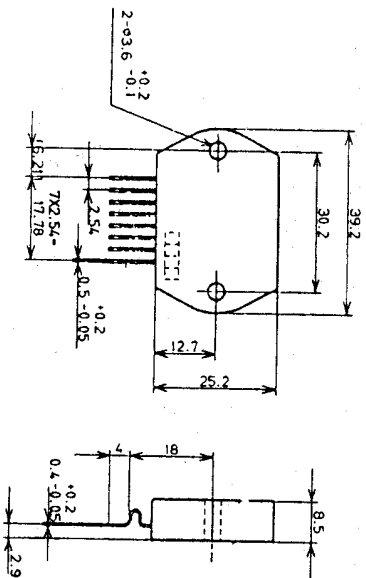

(2)

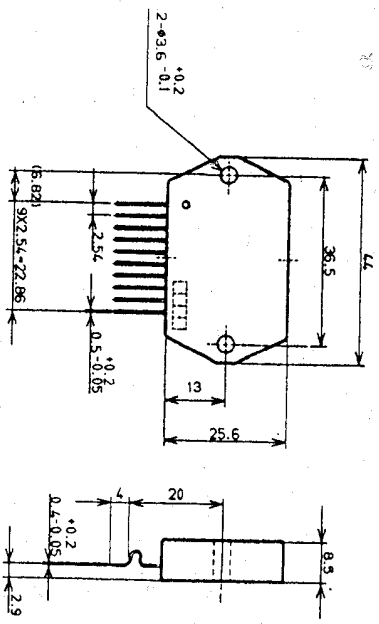

(3)

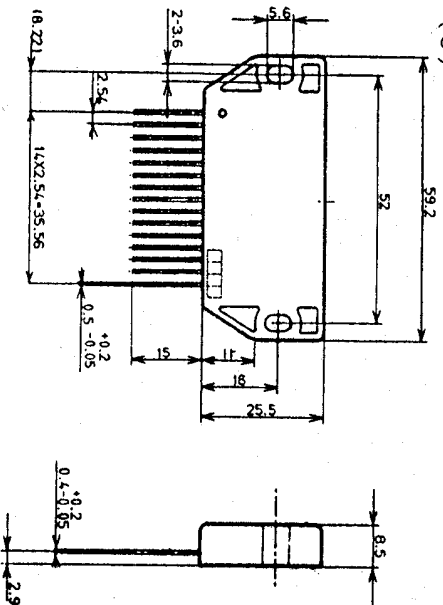

(4)

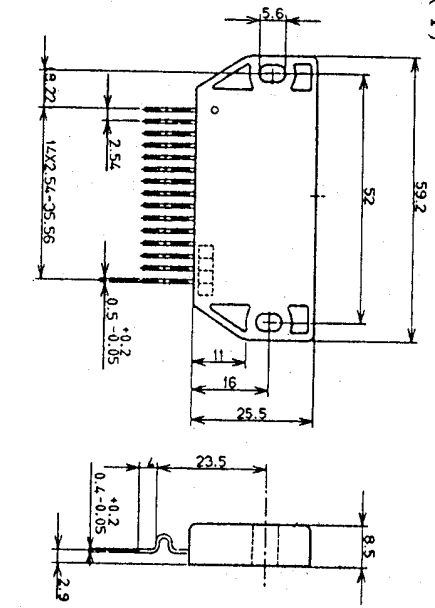

(5)

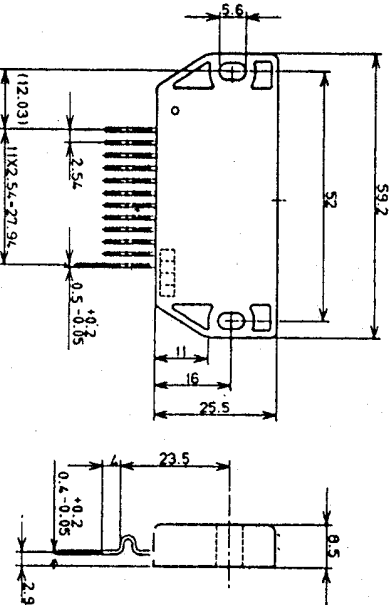

(6)

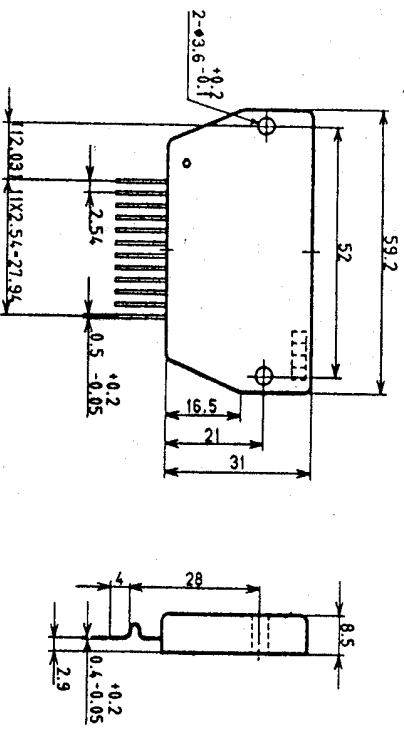

(7)

