

PA300 POWER AMPLIFIER

There are several starting points to the design of a power amplifier: pure hi-fi without any compromise; simplicity and reliability; high output power. The design of the present amplifier is a mixture of these. The result is a unit that does not use esoteric components, is not too complex, and is fairly easily reproduced. In fact, it could well be named a 'Hi-fi public address amplifier'.

There will be a few eyebrows raised at the power output of 300 watts (into 4Ω); it is true, of course, that in the average living room 30–40 W per channel is more than sufficient. However, peaks in the reproduced music may have a power of 10–20 times the average level. This means that some reserve power is desirable. Also, there are loudspeakers around with such a low efficiency that a lot more than 30–40W is needed. And, last but not least, there are many people who want an amplifier for rooms much larger than the average living room, such as an amateur music hall.

Straightforward design

Since every amplifier contains a certain number of standard components, the circuit of Fig. 1 will look pretty familiar to most audio enthusiasts. Two aspects may hit the eye: the higher than usual supply voltage and the presence of a couple of ICs. The first is to be expected in view of the power

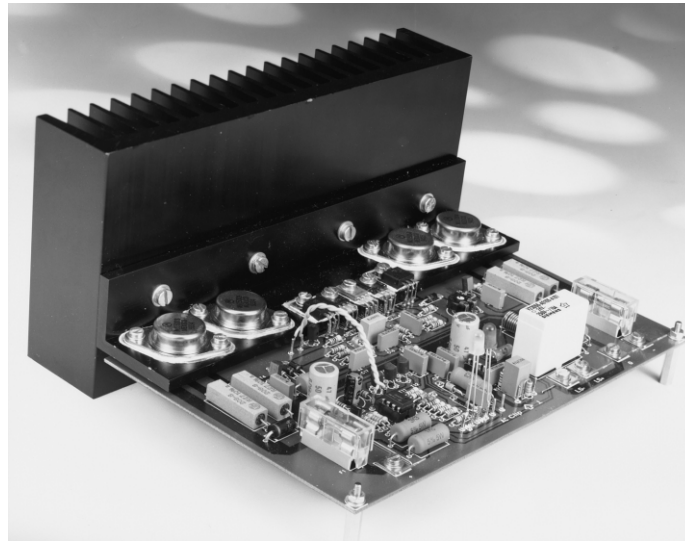

Design by A. Riedl

Taken by themselves, the properties of the PA300 amplifier are not revolutionary. But taken in combination, they show something special: a robust 300 watt hi-fi power amplifier that is not too difficult to build.

output. One of the ICs is not in the signal path and this immediately points to it being part of a protection circuit. What is unconventional is an IC in the input stage. Normally, this stage consists of a differential amplifier followed by a voltage amplifier of sorts, often also a differential amplifier, to drive the predriver stages. In the PA300, the entire input stage is contained in one

IC, a Type NE5534 (IC₁).

The internal circuit of IC₁ is shown in the box on further on in this article. It may also be of interest to note that the NE5534 is found in nine out of every ten CD players (as amplifier in the analogue section). This is reflected in its price which is low. Its only drawback is that its supply voltage is far below that of the remainder of the amplifier. This means an additional symmetrical supply of ±15 V. Moreover, it restricts the drive capability of the input stage. The supply requirement is easily met with the aid of a couple of zener diodes and resistors. The drive restriction means that the amplifier must provide a measure of voltage amplification after the input stage.

Circuit description

The input contains a high-pass filter, C₅-R₃ and a low-pass filter, R₂-C₆. The combination of these filters limits the bandwidth of the input stage to a realistic value: it is not necessary for signals well outside the audio range to be amplified – in fact, this may well

give rise to difficulties.

Opamp IC₁ is arranged as a differential amplifier; its non-inverting (+) input functions as the meeting point for the overall feedback. The feedback voltage, taken from junction D₇-D₈, is applied to junction R₄-R₅ via R₉. Any necessary compensation is provided by C₉, C₁₂ and C₁₄. The voltage amplification is determined by the ratio R₉:R₅, which in the present circuit is ×40.

The output of IC₁ is applied to drive stages T₁ and T₃ via R₆. These transistors operate in Class A: the current drawn by them is set to 10 mA by voltage divider R₁₀-R₁₃ and their respective emitter resistors. Their voltage and current amplification is appreciable, which is as required for the link between the input and output stages.

The output amplifier proper consists of drive stages T₆ and T₇ and power transistors T₈, T₉, T₁₄, T₁₅, which have been arranged as symmetrical power darlingtontons. Because of the high power, the output transistors are connected in parallel. The types used can handle a collector current of 20 A and have a maximum dissipation of 250 W.

The output stages operate in Class AB to ensure a smooth transition between the n-p-n and p-n-p transistors, which prevents cross-over distortion. This requires a small current through the power transistors, even in the absence of an input signal. This current is provided by 'zener' transistor T₂,

Technical data (measured with power supply shown in Fig. 2)

Input sensitivity	1 V _{rms}
Input impedance	17.8 kΩ
Power output (0.1% THD)	164 W into 8 Ω 275 W into 4 Ω
Music power (500 Hz burst 5 cycles on, 5 cycles off)	176 W into 8 Ω 306 W into 4 Ω
Power bandwidth (90 W into 8 Ω)	7 Hz–67 kHz
Slew rate	20 V/μs
Signal-to-noise ratio (referred to 1 W into 8 Ω)	> 96 dB (A-weighted)
Harmonic distortion (THD+N) (bandwidth 80 kHz)	at 1 W into 8 Ω: < 0.004% (1 kHz) at 150 W into 8 Ω: < 0.001% (1 kHz) < 0.05% (20 Hz–20 kHz)
Intermodulation distortion (50 Hz:1 kHz; 4:1)	at 1 W into 8 Ω: < 0.003% at 100 W into 8 Ω: < 0.0035%
Dynamic IM (rectangular wave + 15 kHz sine wave)	1 W into 8 Ω: < 0.004% 150 W into 8 Ω: < 0.06%
Damping factor (at 8 Ω)	< 345 at 1 kHz < 275 at 20 kHz

which puts a small voltage on the bases of T_6 and T_7 so that these transistors just conduct in quiescent operation. The level of the quiescent current is set accurately with P_1 .

To ensure maximum thermal stability, transistors T_1 - T_3 and T_6 - T_7 are mounted on and the same heat sink. This keeps the quiescent current within certain limits. With high drive signals, this current can reach a high level, but when the input sig-

nal level drops, the current will diminish only slowly until it has reached its nominal value.

Diodes D_7 , D_8 protect the output stages against possible counter voltages generated by the complex load. Resistor R_{30} and capacitor C_{17} form a Boucherot network to enhance the stability at high frequencies. Inductor L_1 prevents any problems with capacitive loads (electrostatic loudspeakers). Resistor R_{29} ensures that the transfer of

rectangular signals are not adversely affected by the inductor.

Protection circuits

As any reliable amplifier, the PA300 is provided with adequate protection measures. These start with fuses F_1 and F_2 , which guard against high currents in case of overload or short-circuits. Since even fast fuses are often not fast enough to prevent the

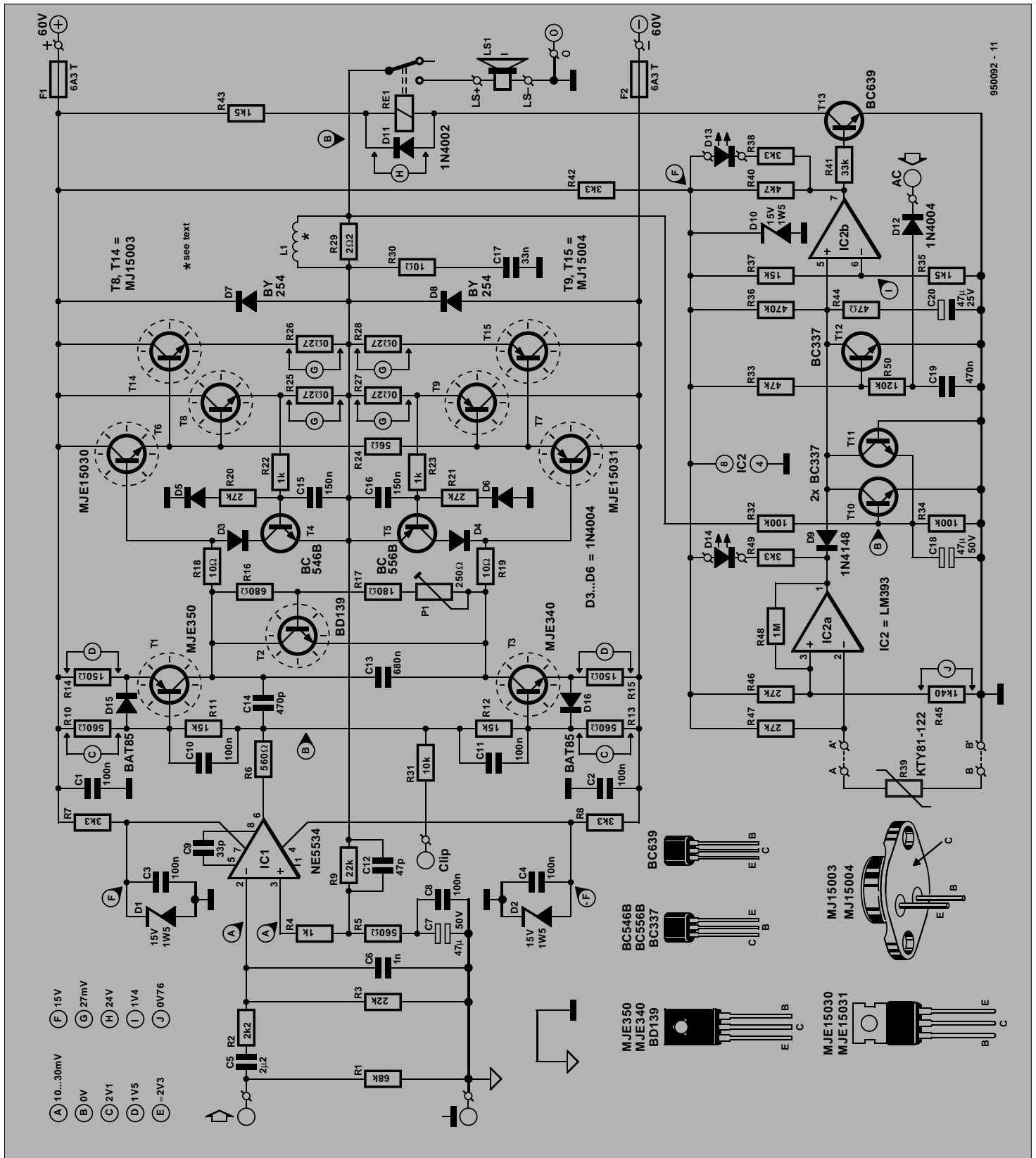

Fig. 1. With the exception of an IC at the input, the circuit of the PA300 amplifier is conventional.

power transistors giving up the ghost in such circumstances, an electronic short-circuit protection circuit, based on T_4 and T_5 , has been provided. When, owing to an overload or short-circuit, very high currents begin to flow through resistors R_{25} and R_{27} , the potential drop across these resistors will exceed the base-emitter threshold voltage of T_4 and T_5 . These transistors then conduct and short-circuit or reduce drive signal at their bases. The output current then drops to zero.

If a direct voltage appears at the output terminals, or the temperature of the heat sink rises unduly, relay Re_1 removes the load from the output. The loudspeakers are also disconnected by the relay when the mains is switched on (power-on delay) to prevent annoying clicks and plops.

The circuits that make all this possible consist of dual comparator IC_2 , transistors T_{10} - T_{13} , and indicator diodes D_{13} and D_{14} . They are powered by the 15 V line provided by zener diode D_{10} and resistor R_{42} .

The 'AC' terminal on the PCB is linked to one of the secondary outputs on the mains transformer. As soon as the mains is switched on, an alternating voltage appears at that terminal, which is rectified by D_{12} and applied as a negative potential to T_{12} via R_{50} . The transistor will then be cut off, so that C_{20} is charged via R_{36} and R_{44} . As long as charging takes place, the inverting (+) input of comparator IC_{2b} is low w.r.t. the non-inverting (-) input. The output of IC_{2b} is also low, so that T_{13} is cut off and the relay is not energized. This state is indicated by the lighting of D_{13} . When C_{20} has been charged fully, the comparator changes state, the relay is energized (whereupon

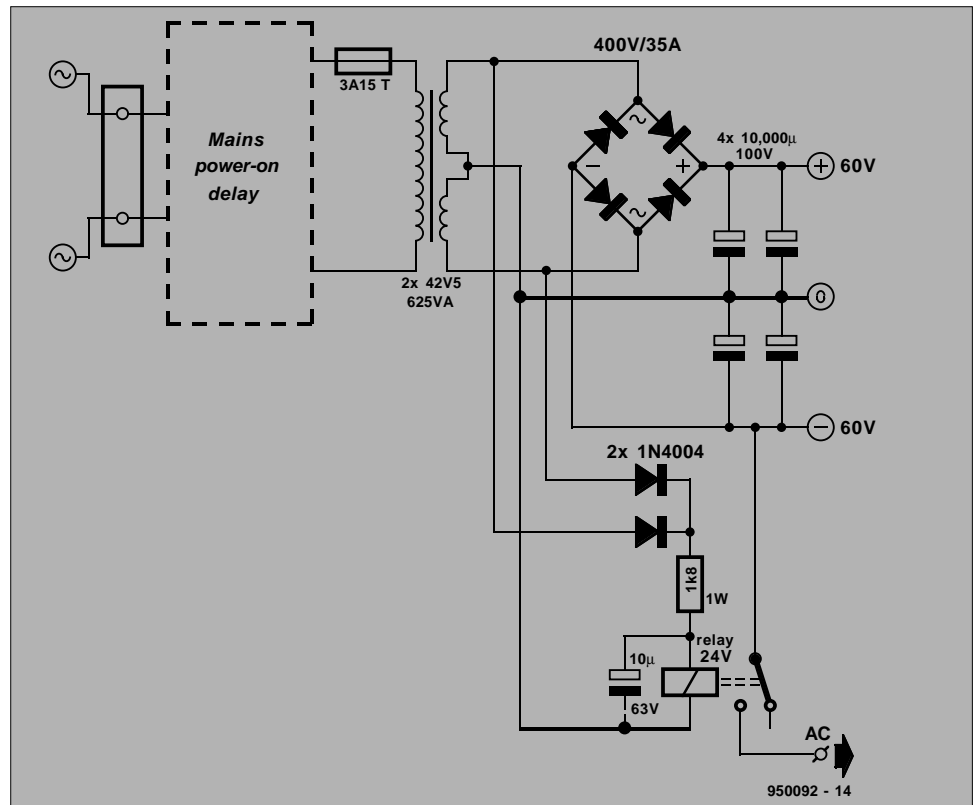

Fig. 2. The power supply is straightforward, but can handle a large current. Voltage 'AC' serves as drive for the power-on delay circuit.

D_{13} goes out) and the loudspeakers are connected to the output. When the mains is switched off, the relay is deenergized instantly, whereupon the loudspeakers are disconnected so that any switch-off noise is not audible.

The direct-voltage protection operates

as follows. The output voltage is applied to T_{10} and T_{11} via potential divider R_{32} - R_{34} . Alternating voltages are short-circuited to ground by C_{18} . However, direct voltages greater than +1.7 V or more negative than -4.8 V switch on T_{10} or T_{11} immediately. This causes the +ve input of IC_{2a} to be pulled down, whereupon this comparator changes state, T_{13} is cut off, and the relay is deenergized. This state is again indicated by the lighting of D_{13} .

Strictly speaking, temperature protection is not necessary, but it offers that little bit extra security. The temperature sensor is R_{39} , a PTC (positive temperature coefficient) type, which is located on the board in a position where it rests against the rectangular bracket. Owing to a rising temperature, the value of R_{39} increases until the potential at the -ve input of IC_{2a} rises above the level at the +ve input set by divider R_{45} - R_{46} , whereupon the output of IC_{2a} goes low. This causes IC_{2b} to change state, whereupon T_{13} is cut off and the relay is deenergized. This time, the situation is indicated by the lighting of D_{14} . The circuit has been designed to operate when the temperature of the heat sink rises above 70 °C. Any relay clatter may be obviated by reducing the value of R_{48} .

The terminal marked 'CLIP' on the PCB is connected to the output of IC_1 via R_{31} . It serves to obtain an external overdrive indication, which may be a simple combination of a comparator and LED. Normally, this terminal is left open.

Power supply

As with most power amplifiers, the ± 60 V

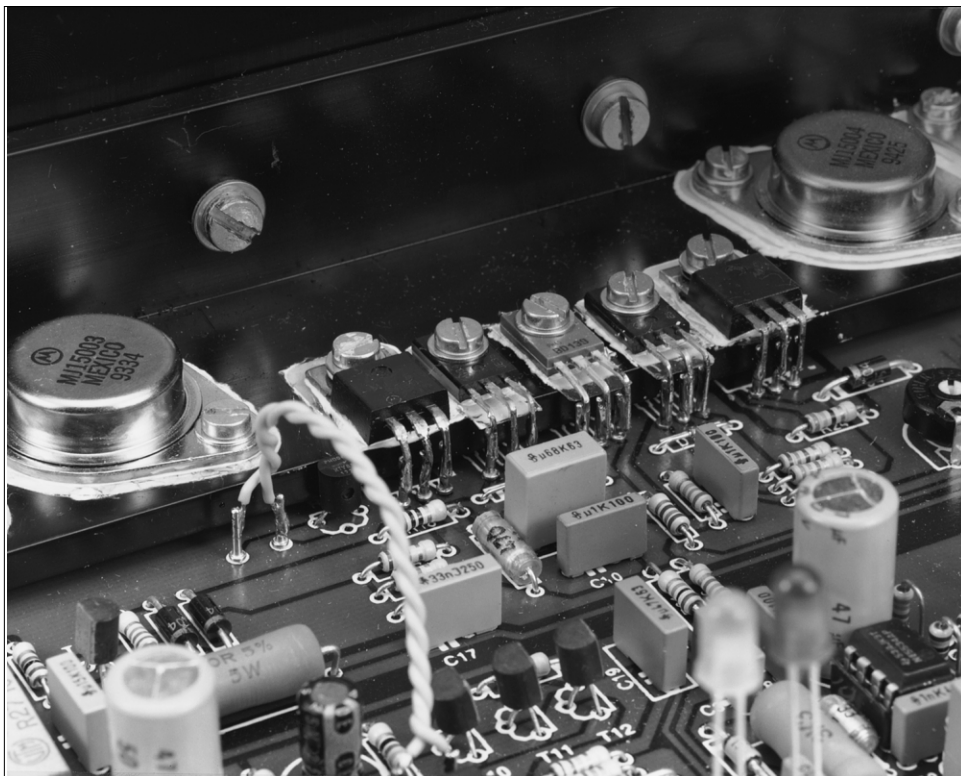

Fig. 3. This close-up photograph shows clearly how the transistors are fitted to the heat sink via a rectangular bracket.

power supply need not be regulated. Owing to the relatively high power output, the supply needs a fairly large mains transformer and corresponding smoothing capacitors—see Fig. 2. Note that the supply shown is for a mono amplifier; a stereo outfit needs two supplies.

The transformer is a 625 VA type, and the smoothing capacitors are 10 000 μF , 100 V electrolytic types. The bridge rectifier needs to be mounted on a suitable heat sink or be mounted directly on the bottom cover of the metal enclosure. The transformer needs two secondary windings, providing 42.5 V each. The prototype used a toroidal transformer with 2 \times 40 V secondaries. The secondary winding of this type of transformer is easily extended: in the prototype 4 turns were added and this gave secondaries of 2 \times 42.5 V.

The box 'Mains power-on delay' provides a gradual build-up of the mains voltage, which in a high-power amplifier is highly advisable. A suitable design was published in *305 Circuits* (page 115).

The relay and associated drive circuit is intended to be connected to terminal 'AC' on the board, where it serves to power the power-on circuit. If a slight degradation of the amplifier performance is acceptable, this relay and circuit may be omitted and the PCB terminal connected directly to one of the transformer secondaries.

Construction

Building the amplifier is surprisingly simple. The printed-circuit board in Fig. 4 is well laid out and provides ample room. Populating the board is as usual best started with the passive components, then the electrolytic capacitors, fuses and relay. There are no 'difficult' parts.

Circuits IC₁ and IC₂ are best mounted in appropriate sockets.

Diodes D₁₃ and D₁₄ will, of course, have to be fitted on the front panel of the enclosure and are connected to the board by lengths of flexible circuit wire.

Inductor L₁ is a DIY component; it consists of 15 turns of 1 mm. dia. enamelled copper wire around R₂₉ (not too tight!).

Since most of the transistors are to be mounted on and the same heat sink, they are all located at one side of the board. However, they should first be fitted on a rectangular bracket, which is secured to the heat sink and the board—see Fig. 3. Note that the heat sink shown in this photograph proved too small when 4 Ω loudspeakers were used. With 8 Ω speakers, it was just about all right, but with full drive over sustained periods, the temperature protection circuits were actuated. If such situations are likely to be encountered, forced cooling must be used.

As already stated, temperature sensor R₃₉ should rest (with its flat surface) against the rectangular bracket. On the board, terminals 'A' and 'B' terminals to the left of R₃₉ must be connected to 'A' and 'B' above IC₂ with a twisted pair of lengths of insulated circuit wire as shown in Fig. 3.

The points where to connect the loud-

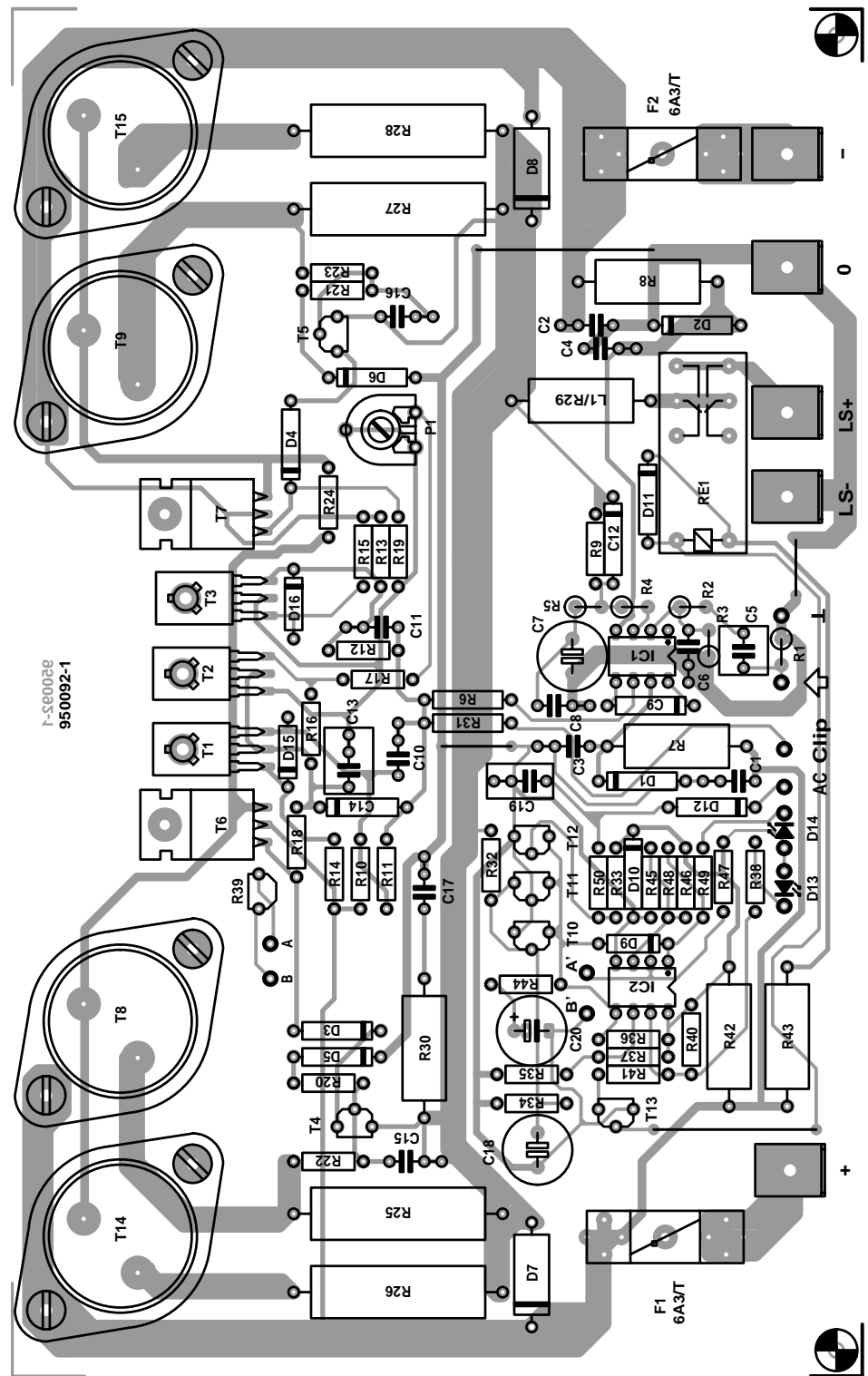

Fig. 4a. Component layout of the printed-circuit board for the 300 W power amplifier.

speaker leads and power lines are clearly marked on the board. Use the special flat AMP connectors for this purpose: these have large-surface contacts that can handle large currents. The loudspeaker cable should have a cross-sectional area of not less than 2.5 mm².

Finally

How the amplifier and power supply are assembled is largely a question of individual taste and requirement. The two may be

combined into a mono amplifier, or two each may be built into a stereo amplifier unit. Our preference is for mono amplifiers, since these run the least risk of earth loops and the difficulties associated with those. It is advisable to make the '0' of the supply the centre of the earth connections of the electrolytic capacitors and the centre tap of the transformer.

The single earthing point on the supply and the board must be connected to the enclosure earth by a short, heavy-duty cable. This means that the input socket must be

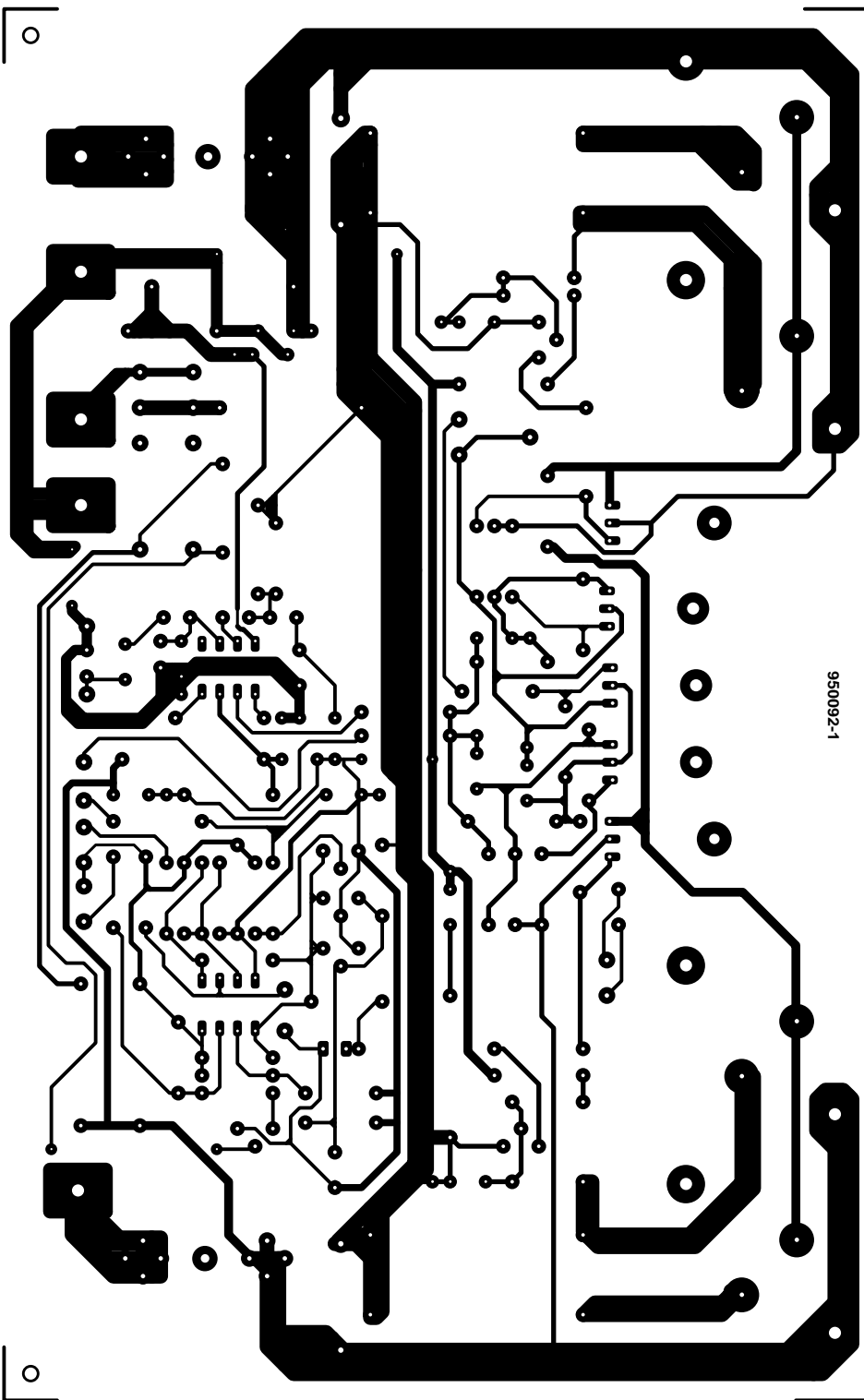

Fig. 4b. Track layout of the printed-circuit board for the 300 W power amplifier.

an insulated type. This socket must be linked to the input on the board via screened cable.

To test the amplifier, turn P_1 fully anti-clockwise and switch on the mains. After the output relay has been energized, set the quiescent current. This is done by connecting a multimeter (direct mV range) across one of resistors R_{25} – R_{28} and adjusting P_1 until the meter reads 27 mV (which corresponds to a current of 100 mA through each of the four power transistors). Leave the amplifier on for an hour or so and then check the voltage again: adjust P_1 as re-

quired.

Test results

The technical data given on page 00 were verified or obtained with a power supply as shown in Fig. 2. They show that in spite (or because?) of its simple design, the amplifier offers excellent performance. The distortion figures are particularly good.

Measurements with the Audio Precision analyser are illustrated in Fig. 5.

Figure 5a shows the total harmonic distortion (THD+N) over a frequency range of

20 Hz to 20 kHz with a bandwidth of 80 kHz and a power output of 150 W into 8 Ω . Up to 1 kHz, the distortion is very low and then increases, which is usual and caused by the inertia of the semiconductors.

Figure 5b shows the distortion at 1 kHz as a function of the output level at a bandwidth of 22 Hz to 22 kHz. The dashed curve refers to a load of 4 Ω and the solid curve to a load of 8 Ω . The irregularities between 10 W and 100 W are not caused by the amplifier but by the limits of the measuring range of the analyser. From the clipping points, the curves rise almost vertically.

Figure 5c shows the maximum for a distortion of 0.1%. The dashed curve (4 Ω load) is very close to the 300 W line. The small reduction at low frequencies is caused by the imperfectness of the electrolytic buffer capacitors in the power supply.

Figure 5d shows the Fourier analysis of a 1 kHz signal for a power output of 1 W into 8 Ω . The fundamental frequency is suppressed. The 2nd and 3rd harmonics are down by 110 dB and 120 dB respectively referred to the fundamental frequency. The THD+N figure at this measurement was 0.0009%.

Parts list

Resistors:

- $R_1 = 68 \text{ k}\Omega$
- $R_2 = 2.2 \text{ k}\Omega$
- $R_3, R_9 = 22 \text{ k}\Omega$
- $R_4, R_{22}, R_{23} = 1 \text{ k}\Omega$
- $R_5, R_6, R_{10}, R_{13} = 560 \Omega$
- $R_7, R_8, R_{42} = 3.3 \text{ k}\Omega, 5 \text{ W}$
- $R_{11}, R_{12}, R_{37} = 15 \text{ k}\Omega$
- $R_{14}, R_{15} = 150 \Omega$
- $R_{16} = 680 \Omega$
- $R_{17} = 180 \Omega$
- $R_{18}, R_{19} = 10 \Omega$
- $R_{20}, R_{21}, R_{46}, R_{47} = 27 \text{ k}\Omega$
- $R_{24} = 56 \Omega$
- R_{25} – $R_{28} = 0.27 \Omega, 5 \text{ W}$
- $R_{29} = 2.2 \Omega, 5 \text{ W}$
- $R_{30} = 10 \Omega, 5 \text{ W}$
- $R_{31} = 10 \text{ k}\Omega$
- $R_{32}, R_{34} = 100 \text{ k}\Omega$
- $R_{33} = 47 \text{ k}\Omega$
- $R_{35} = 1.5 \text{ k}\Omega$
- $R_{36} = 470 \text{ k}\Omega$
- $R_{38}, R_{49} = 3.3 \text{ k}\Omega$
- $R_{39} = \text{sensor Type KTY81-122}$
- $R_{40} = 4.7 \text{ k}\Omega$
- $R_{41} = 33 \text{ k}\Omega$
- $R_{43} = 1.5 \text{ k}\Omega, 5 \text{ W}$
- $R_{44} = 47 \Omega$
- $R_{45} = 1.40 \text{ k}\Omega, 1\%$
- $R_{48} = 1 \text{ M}\Omega$
- $R_{50} = 120 \text{ k}\Omega$
- $P_1 = 250 \Omega \text{ preset}$

Capacitors:

- C_1 – $C_4, C_8, C_{10}, C_{11} = 100 \text{ nF}$
- $C_5 = 2.2 \mu\text{F}$ polypropylene, pitch 5 mm
- $C_6 = 1 \text{ nF}$
- $C_7, C_{18} = 47 \mu\text{F}, 50 \text{ V}, \text{bipolar, radial};$
- $C_9 = 33 \text{ pF}, 160 \text{ V}, \text{polystyrene}$
- $C_{12} = 47 \text{ pF}, 160 \text{ V}, \text{polystyrene}$

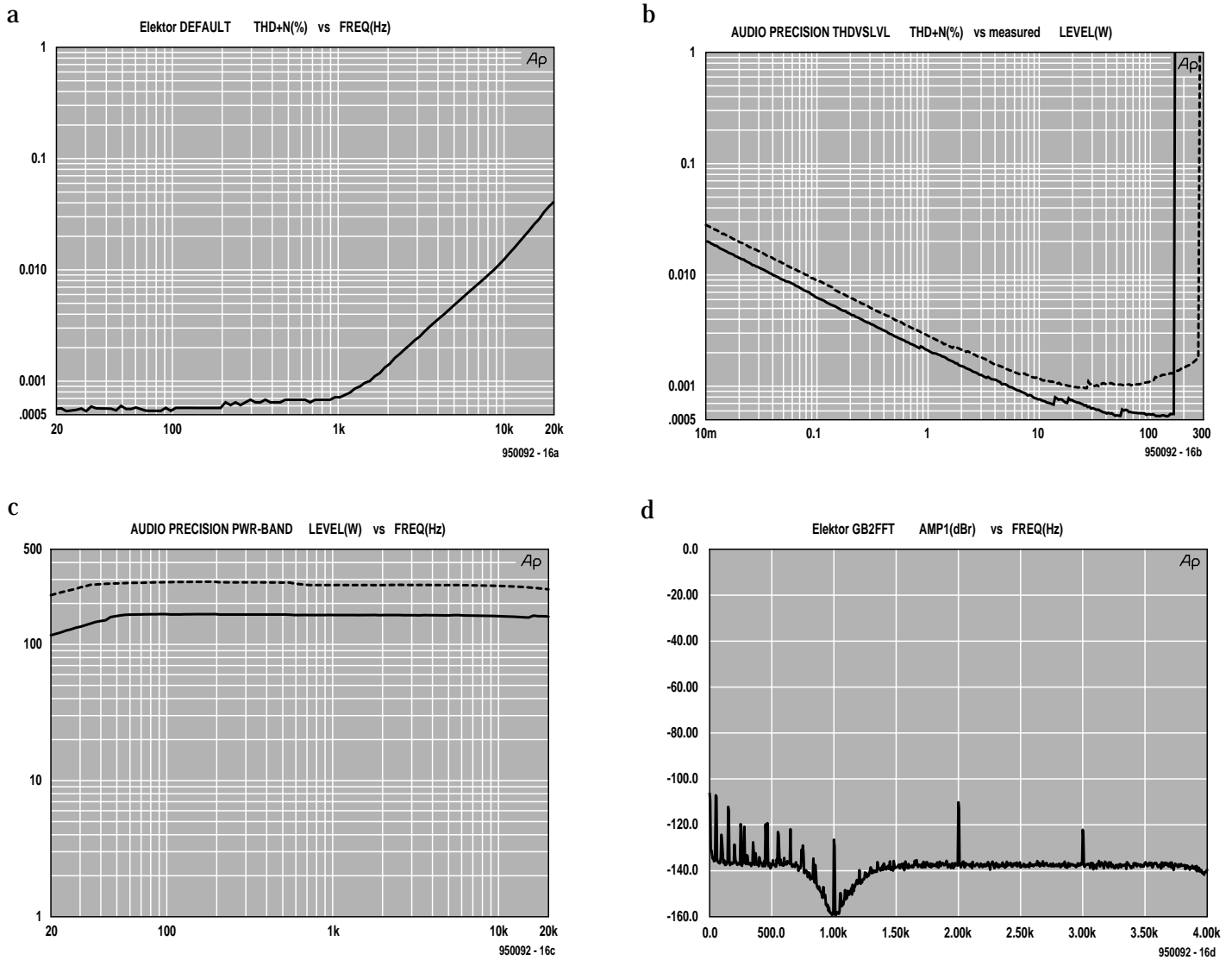

Fig. 5. Curves obtained during measurements on the amplifier with an Audio Precision Analyser (see text).

$C_{13} = 680 \text{ nF}$
 $C_{14} = 470 \text{ pF}$, 160 V, polystyrene
 $C_{15}, C_{16} = 150 \text{ nF}$
 $C_{17} = 33 \text{ nF}$
 $C_{19} = 470 \text{ nF}$
 $C_{20} = 47 \text{ }\mu\text{F}$, 25 V, radial
 Semiconductors:
 $D_1, D_2, D_{10} = \text{zener}$, 15 V, 1.5 W
 $D_3, D_6, D_{12} = 1\text{N}4004$
 $D_7, D_8 = \text{BY}254$
 $D_9 = 1\text{N}4148$
 $D_{11} = 1\text{N}4002$
 $D_{13}, D_{14} = \text{LED}$
 $D_{15}, D_{16} = \text{BAT}85$
 $T_1 = \text{MJE}350$
 $T_2 = \text{BD}139$
 $T_3 = \text{MJE}340$
 $T_4 = \text{BC}546\text{B}$
 $T_5 = \text{BC}556\text{B}$
 $T_6 = \text{MJE}15030$
 $T_7 = \text{MJE}15031$
 $T_8, T_{14} = \text{MJ}15003$
 $T_9, T_{15} = \text{MJ}15004$
 $T_{10}, T_{12} = \text{BC}337$
 $T_{13} = \text{BC}639$

Integrated circuits:
 $\text{IC}_1 = \text{NE}5534$

$\text{IC}_2 = \text{LM}393$

Miscellaneous:

$L_1 = \text{see text}$
 $\text{Re}_1 = 16 \text{ A}$, 24 V, 875 Ω relay (e.g. Siemens V23056-AO105-A101*)
 $F_1, F_2 = \text{glass fuse}$, 6.3 A, slow complete with PCB type holder
 Loudspeaker and mains connectors for board mounting (AMP - see text)
 Mica washers for T_1-T_3, T_6-T_9, T_{14} and T_{15}
 Rectangular bracket e.g. SWP40, 20 cm long (Fischer 40 \times 30 \times 5**)
 Heat sink < 0.4 K W⁻¹
 PCB Order no. 950092
 Mains transformer, 2 \times 42.5 V, 625 VA (see text)
 Fuse (power supply) 3.15 A, slow, $I^2t \geq 400$
 Bridge rectifier 400 V, 35 A
 4 off electrolytic capacitors, 10,000 μF , 100 V
 PCB Order No. 924055

[950092]

* ElectroValue 01784 33603 or 0161 432 4945

** Dau 01243 553 031; trade only, but information on your nearest dealer will be

given by telephone.

NE/SA/SE5534/5534A

D, FE, N Packages

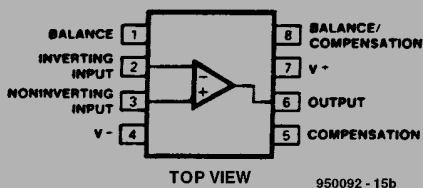

The NE5534

The NE5534 is a good quality, versatile, low-noise operational amplifier which is excellent value for money.

Compared with older types, it has better noise figures, small signal performance, power bandwidth, and output drive capability.

These characteristics make it ideally suited to high-end audio applications. It is found even in the most expensive CD players.

The adjacent simplified diagram gives an idea of the internal structure of this versatile device. It consists of a number of differential amplifiers that are set with the aid of current sources and current mirrors. Well-designed compensation circuits result in excellent linearity and very low distortion.

The standard design gives an amplification of $\times 3$. The frequency response can be optimized for various applications with the aid of an external capacitor. It may be adjusted for a capacitive load, high slew rate, low overshoot or for application as a unity amplifier.

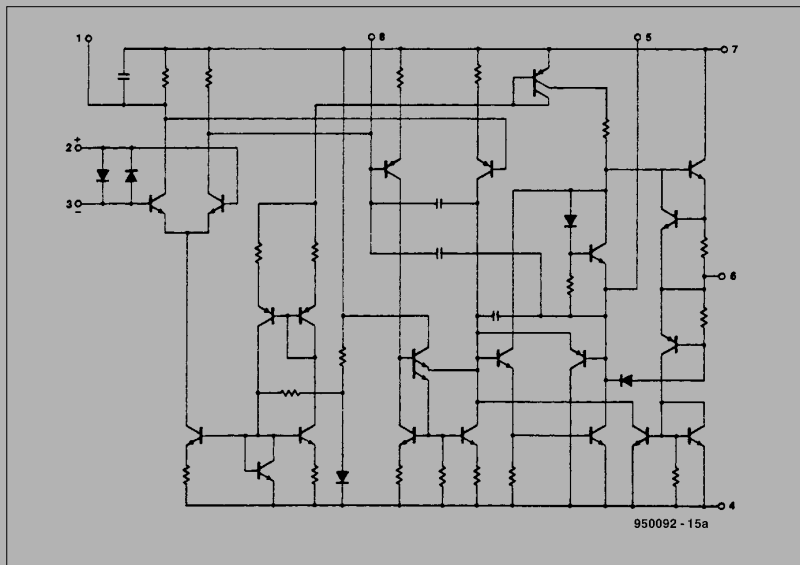

Some technical data

Small-signal bandwidth	10 MHz
Output voltage (at $U_b = \pm 18\text{ V}$)	10 V _{rms} across 600 Ω
Input noise	4 nV Hz ⁻¹
DC voltage amplification	10 ⁵
AC voltage amplification	6 $\times 10^3$ at 10 kHz
Power bandwidth	200 kHz
Slew rate	13 V μs^{-1}
Supply voltage range	$\pm 3\text{ V}$ to $\pm 20\text{ V}$