



THOMSON

AUDIO



SERVICE MANUAL DOCUMENTATION TECHNIQUE TECHNISCHE DOKUMENTATION DOCUMENTAZIONE TECNICA DOCUMENTACION TECNICA

CS100 CS105

Version (PC*): A

*PC: The version code is indicated either in the battery compartment or on the back of the unit - ce code version est indiqué dans le compartiment à piles ou au dos de l'appareil - PC: Version des Geräts wird im Batteriefach oder auf der Rückseite angegeben - il codice della versione è indicato nello scompartimento delle batterie o sul retro dell'apparecchio - el código de la versión está indicado en el compartimento de las pilas o en la parte trasera del aparato.



Technical data - Caractéristiques principales Technische Daten - Dati tecnici - Características del aparato

Type of set: Type d'appareil: Geräteart: Tipo d'apparecchio: Tipo de aparato:	Two-in-one horizontale combination/DAD Ensemble compact stéréophonique DAD-2er Horizontal Kompaktanlage Compatto Hifi/CD Equipo compacto estereofónico/DAD	
Power supply: Alimentation: Stromversorgung: Alimentazione: Alimentación:	230 V ~ 50Hz	Nominal output power: Puissance nominale de sortie: Nennausgangsleistung: Potenza nominale di uscita: Potencia nominal de salida:
 FM - MF: MW - PO: LW - GO:	87,5 - 108 MHz 522 - 1620 kHz 146 - 281 kHz	Sensitivity: Sensibilité: Empfindlichkeit: Sensibilità: Sensibilidad:
 Frequency response: Courbe de réponse: Frequenzgang: Curva di risposta: Curva de respuesta:	125 Hz - 6,3 kHz (+3/-5 dB)	Signal to noise ratio: Rapport signal / bruit: Geräuschspannungabstand: Rapporto segnale / disturbo: Relación señal / ruido:
Wow and flutter: Fluctuations: Gleichlauf: Fluttuazioni: Fluctuaciones:	0,35%	 4,75 cm/s C60: 170s
DAD Disc rotation speed: Vitesse de rotation du disque: CD-Drehgeschwindigkeit: Velocità di rotazione del disco: Velocidad de rotación del disco:	200 → 500 tr/mn	Frequency response: Courbe de réponse: Frequenzgang: Curva di risposta: Curva de respuesta:
Dynamic range: Gamme dynamique: Dynamikumfang: Dinamica: Dinámica:	60 dB	Signal to noise ratio: Rapport signal / bruit: Geräuschspannungabstand: Rapporto segnale / disturbo: Relación señal / ruido:



WARNING : Before servicing this chassis please read the safety recommendations.
ATTENTION : Avant toute intervention sur ce châssis, lire les recommandations de sécurité.
ACHTUNG : Vor jedem Eingriff auf diesem Chassis, die Sicherheitsvorschriften lesen.
ATTENZIONE : Prima di intervenire sullo chassis, leggere le norme di sicurezza.
IMPORTANTE : Antes de cualquier intervención, leer las recomendaciones de seguridad.

Code : 357 268 00 - 1003 / 3,7M - CRKD2110Print.

ADJUSTMENTS - RÉGLAGES - EINSTELLUNGEN - REGOLAZIONI - AJUSTES

AM alignment					
		Gf	f	18888 kHz	
IF	1	↗	450 kHz	↔	T201
	2		MW	522 kHz	←
	3	1620 kHz		↔	↗
Osc	4	↘	150 kHz	←	L205
	5		283 kHz	↔	↗
MW	6	↗	603 kHz	603 kHz	MW coil
	7		1404 kHz	1404 kHz	TC203
LW	8	↘	164 kHz	164 kHz	LW coil
	9		272 kHz	272 kHz	TC202

FM alignment					
		Gf	f	18888 kHz	
IF	1	↗	10,7 MHz	↔	↗
			↘		
		↗	Ve = 1 mV		symetry
Osc	2	↗	87,5 MHz	←	L202
	3		108 MHz	↔	↗
		↘	Ve = 1 mV		Vt = 2.0 ±0.1 V
RF	4	↗	90 MHz	90 MHz	L201
	5		106 MHz	106 MHz	TC201

IC204 LA4282

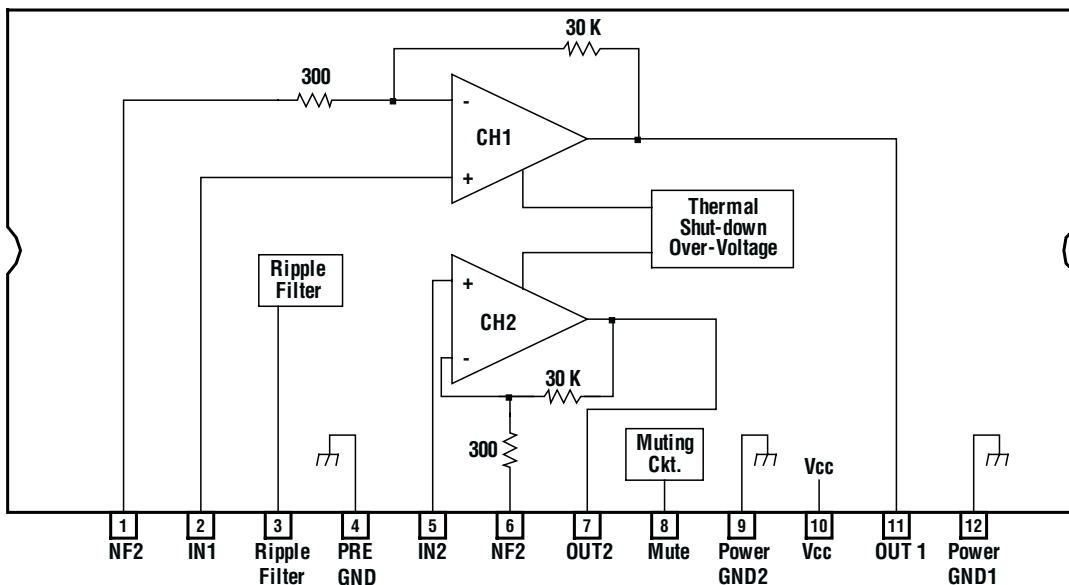

IC204 LA4282

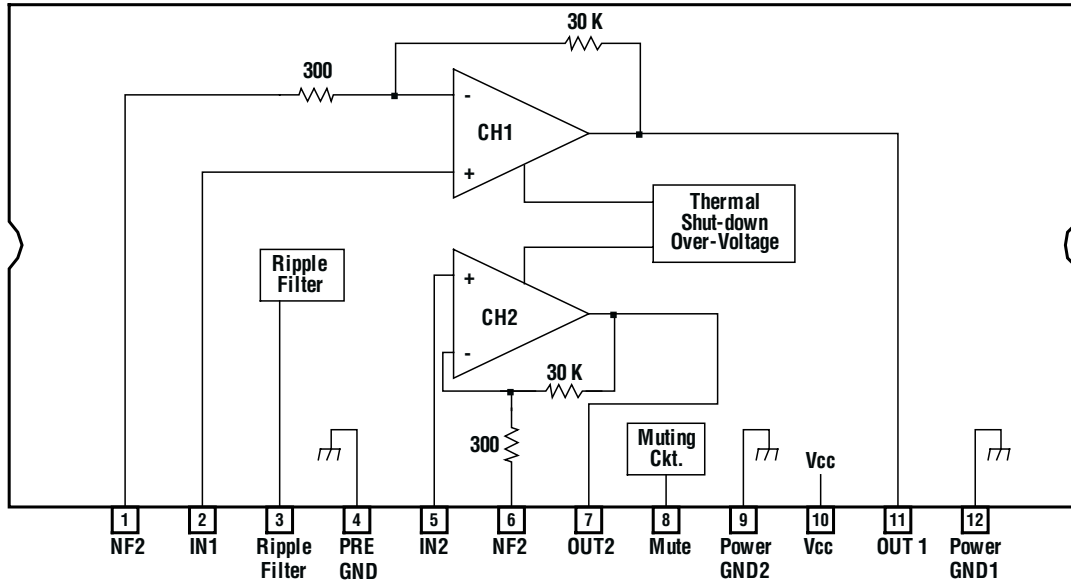

IC4 ST24C02

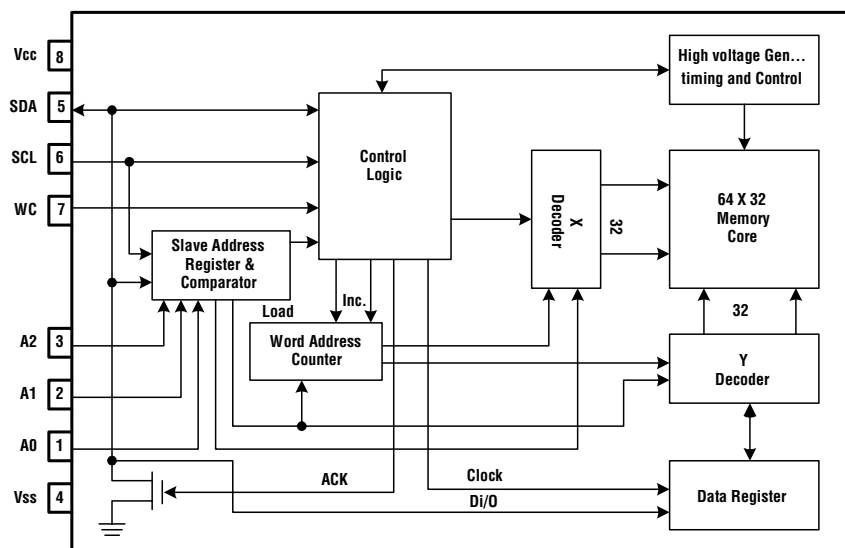

Abbreviations - Abreviations - Abkürzungen - Abbreviazioni - Abreviaciones

B_CUT	Beatcut	PWR_FAIL	Power Failure
CD_EN	CD Enable	PWR_SW	Power Switch
E. HD	Erase Head	R.SPK+	Right Speaker positive
GND	Ground	RCH	Right Chanel
L.SPK+	Left Speaker positive	RCH_O/P	Right Chanel Output
LCH	Left Chanel	REC_CTRL	Record Control
LCH_O/P	Left Chanel Output	REC_SW	Record Switch
LCH_RECIN	Left Chanel Record In	REC_SYNC	Record Synchronisation
LCH_RECIN	Right Chanel Record In	SPK-	Speaker negative
MOTOR_CTRL	Motor Control	SYN_REC	Synchronisation in Record mode
NC	Not Connected	TUNER_EN	Tuner Enable

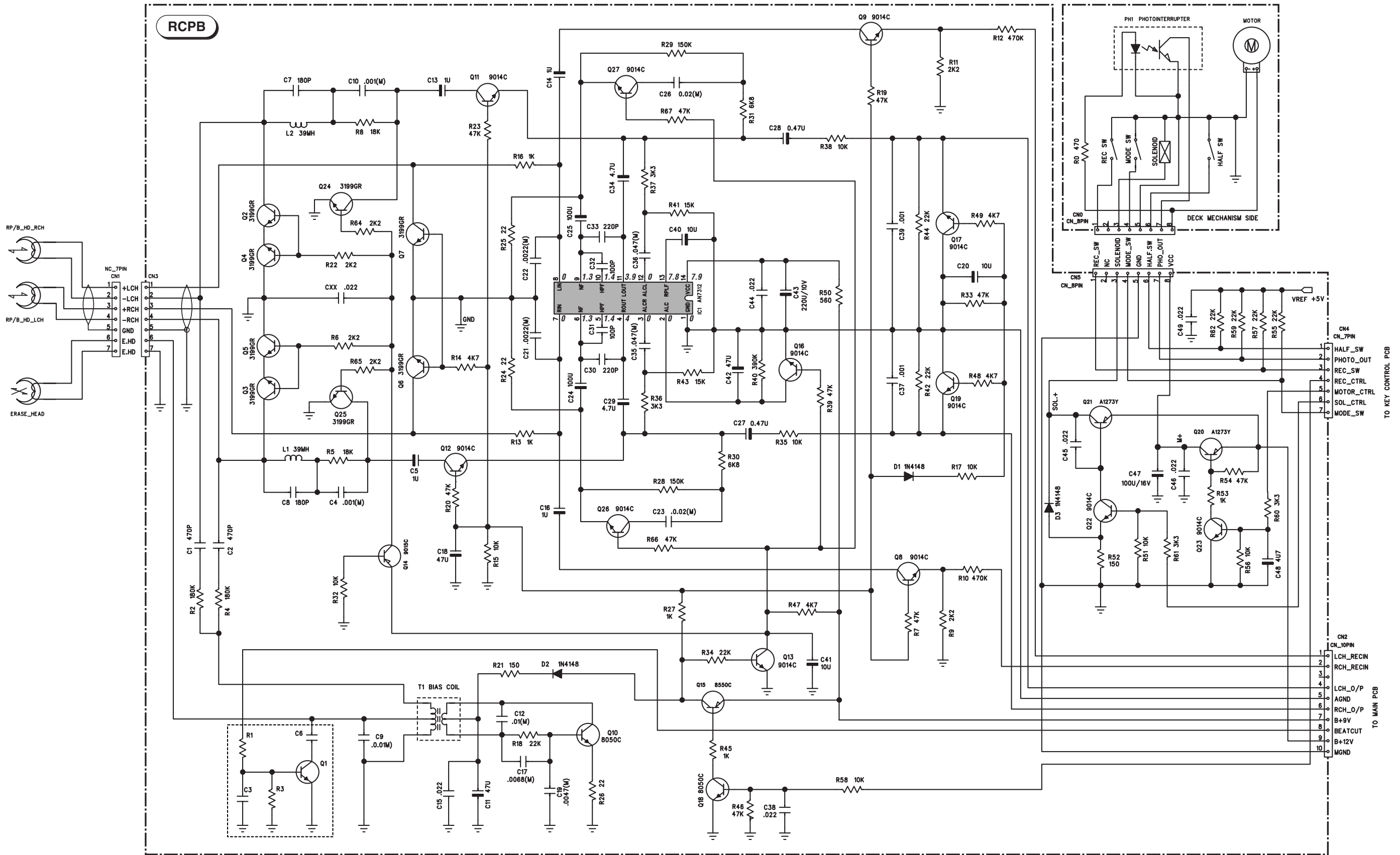



CLASS 1 LASER PRODUCT
APPAREIL A LASER DE CLASSE 1
LASER KLASSE 1
APARATO CON LASER DE CLASE 1
APPARECCHIO CON LASER DI CLASSE 1

DANGER :

Invisible laser radiation when open and interlock failed or defeated. Avoid direct exposure to beam.

ATTENTION :

Le rayon laser est invisible. Eviter l'exposition directe lors de la maintenance.

VORSICHT BEI REPARATUREN :

Bei geöffneter Schublade und Defekt der Sicherheits-
vorrichtungen besteht die Gefahr unsichtbaren
Laserlichts. Niemals direkt in den Laserstrahl sehen.

ATTENZIONE :

Il raggio laser è invisibile. Evitare l'esposizione diretta durante la manutenzione.

IMPORTANTE :

El rayo laser es invisible. Evitar la exposición directa en el momento del mantenimiento.

The complete Digital Processing Module is available from A.S.S. under Part Number :
En SAV, l'ensemble du module traitement digital est géré sous le code :
Die Service Bestell-Nr. für das Modul "Digital Processing kompl." ist :
Il codice del modulo completo di elaborazione digitale è :
En postventa, el modulo completo tratamiento digital lleva el código :

107 357 90

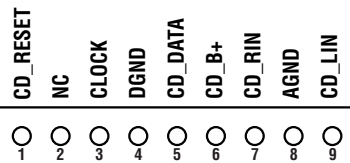

To Main Board

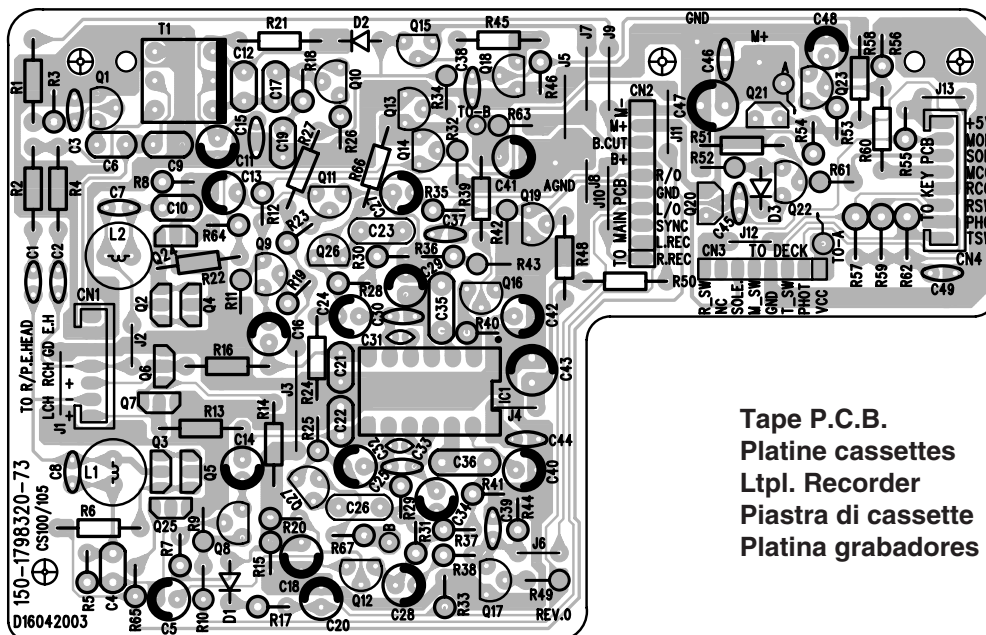

Tape P.C.B.
Platine cassettes
Ltpl. Recorder
Piastra di cassette
Platina grabadores

POWER SUPPLY SCHEMATIC DIAGRAM - SCHEMA DE L'ALIMENTATION - SCHALTBILD
 NETZTEIL - SCHEMA DELL' ALIMENTAZIONE - ESQUEMA DE LA ALIMENTACIÓN

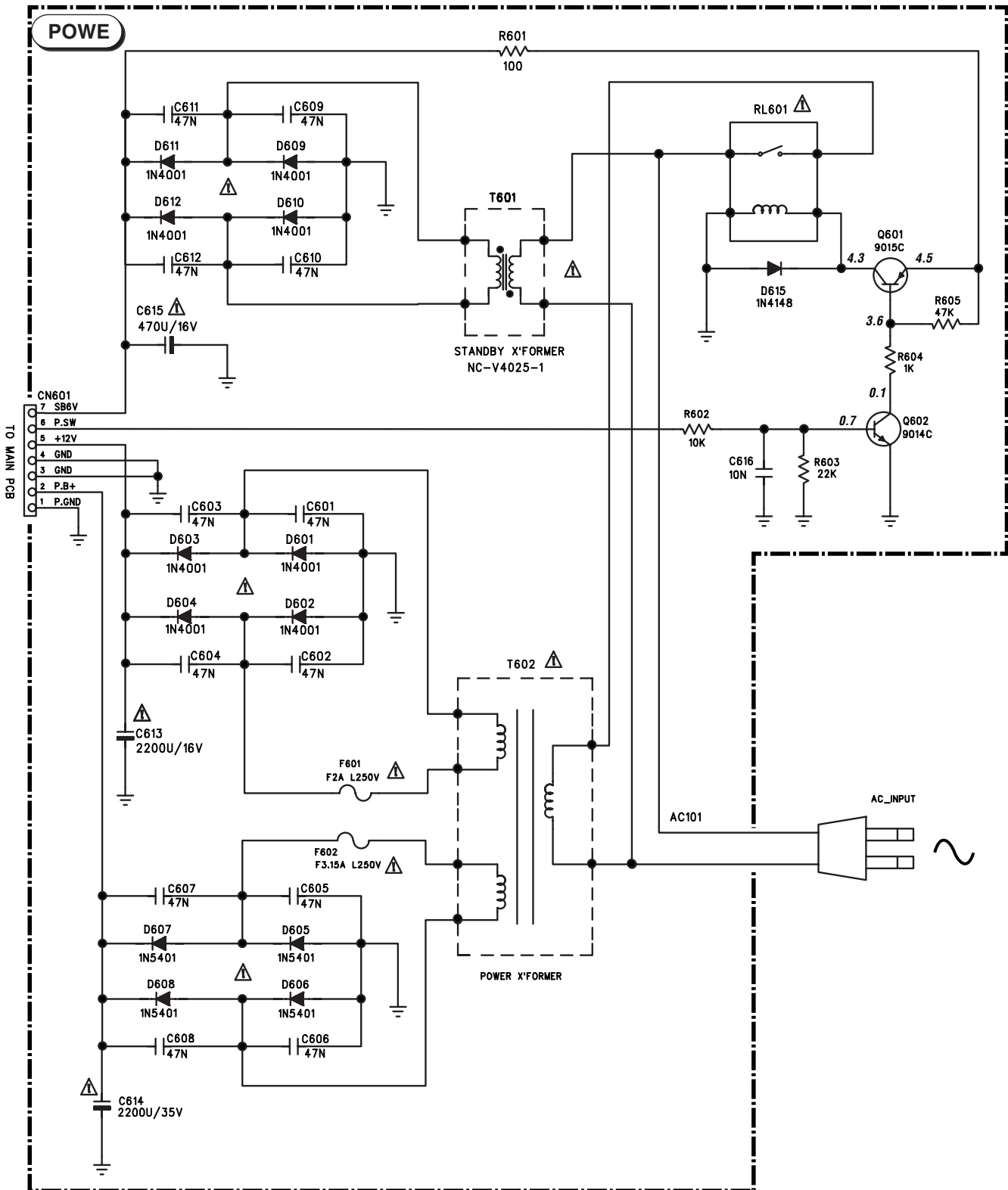

Power supply P.C.B.
 Platine alimentation
 Ltpl. Netzteil
 Piastra alimentazione
 Platina alimentación

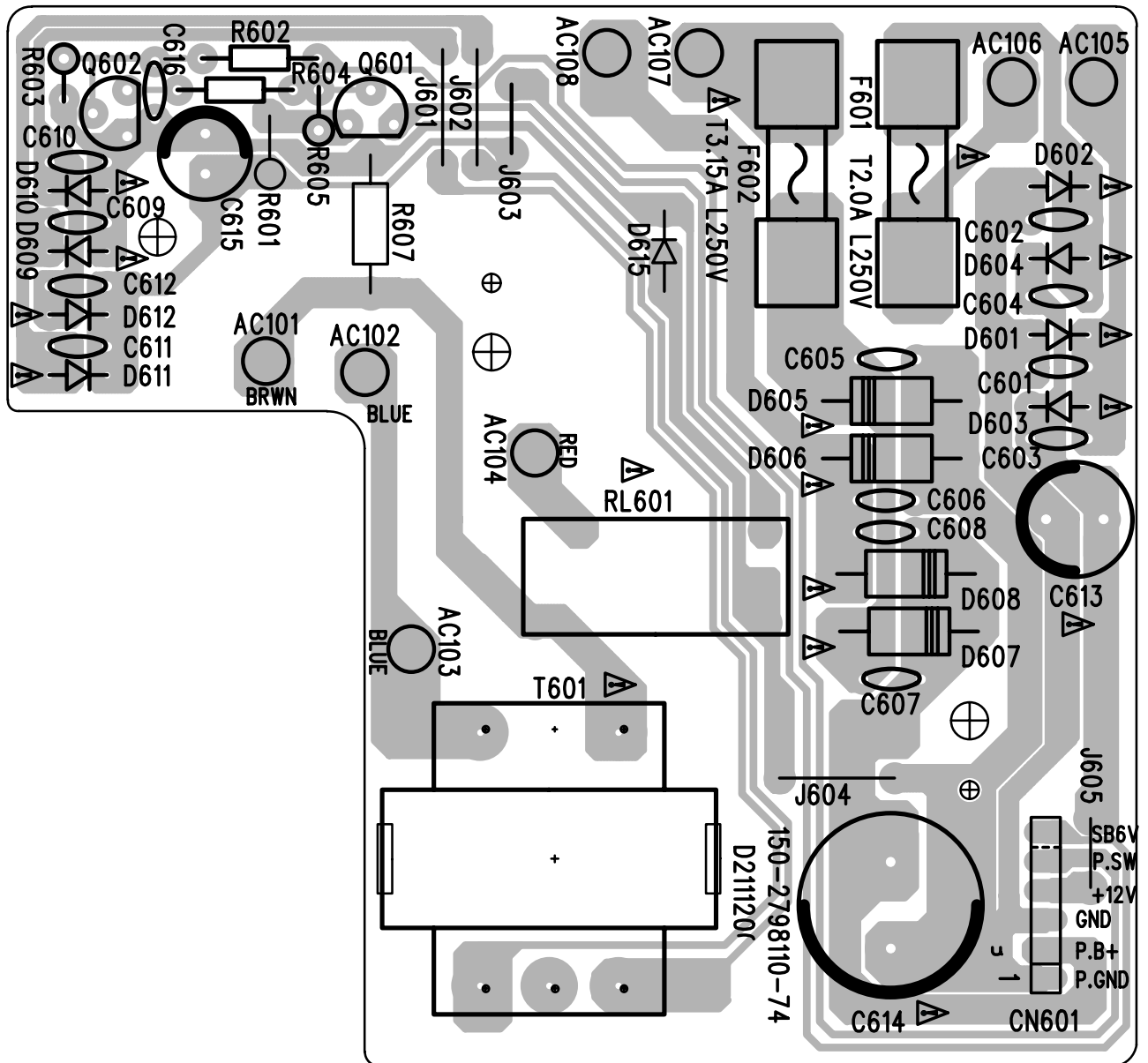

MAIN SCHEMATIC DIAGRAM - SCHEMA DE LA PLATINE PRINCIPALE - GRUNDPLATTE SCHALTBILD - SCHEMA DELLA PIASTRA PRINCIPALE- ESQUEMA DE LA PLATINA PRINCIPAL

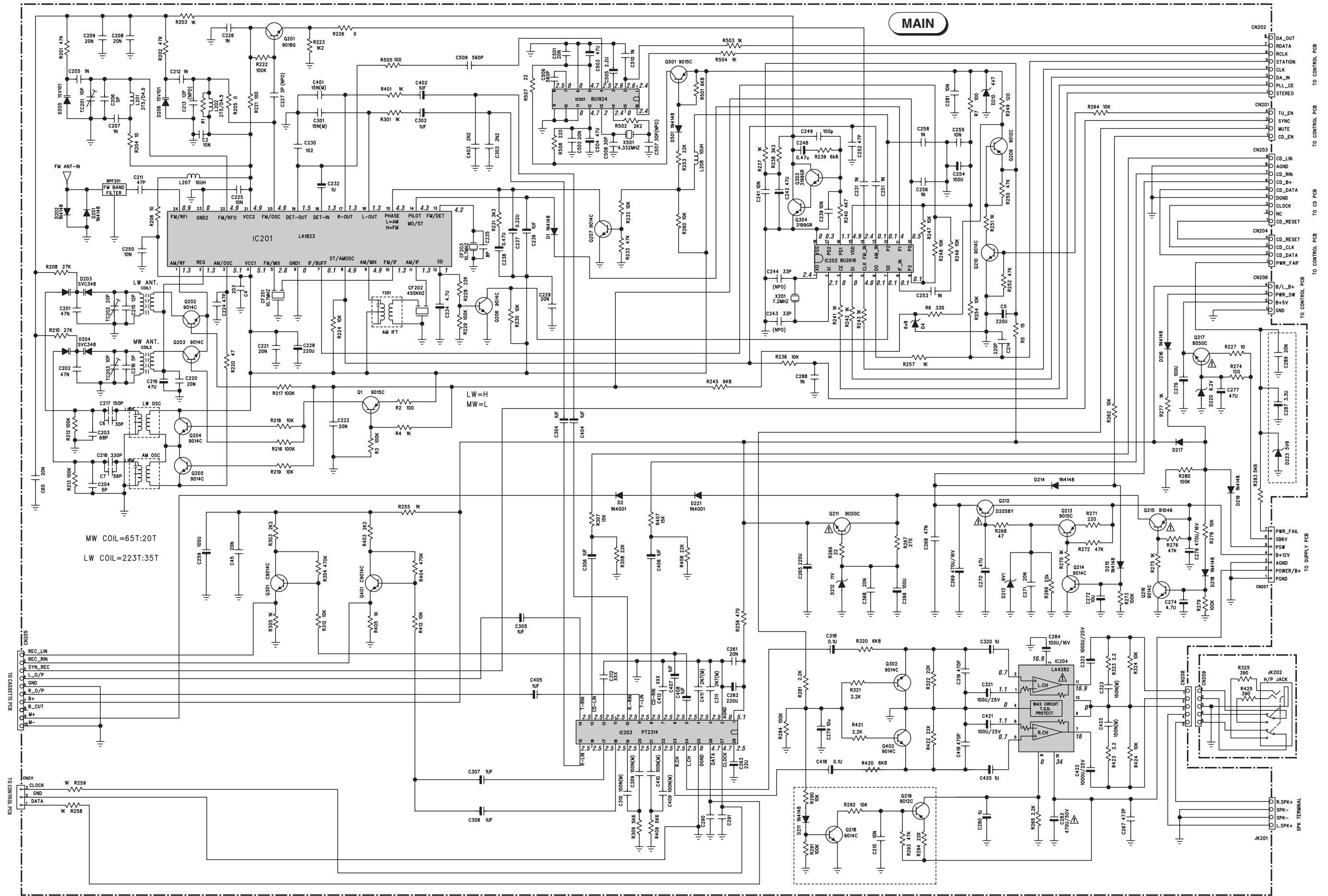

Main P.C.B.
Platine principale
Grundplatte
Piastra principale
Platina principal

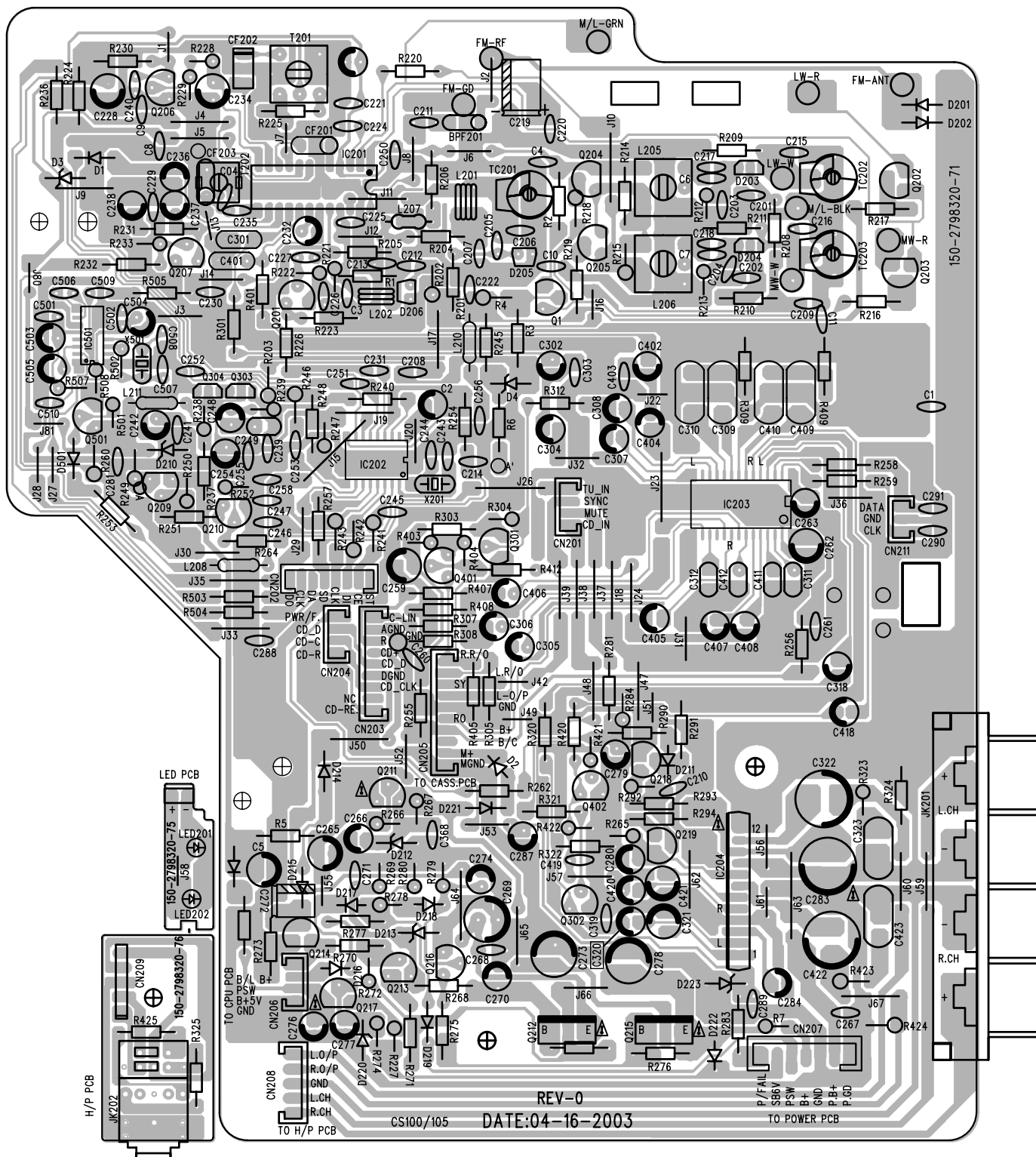

CONTROL / DISPLAY SCHEMATIC DIAGRAM - SCHEMA COMMANDES / AFFICHEUR - BEDIENTEIL / ANZEIGE SCHALTBILD - SCHEMA COMANDI / INDICATORE - ESQUEMA MANDOS / INDICADOR

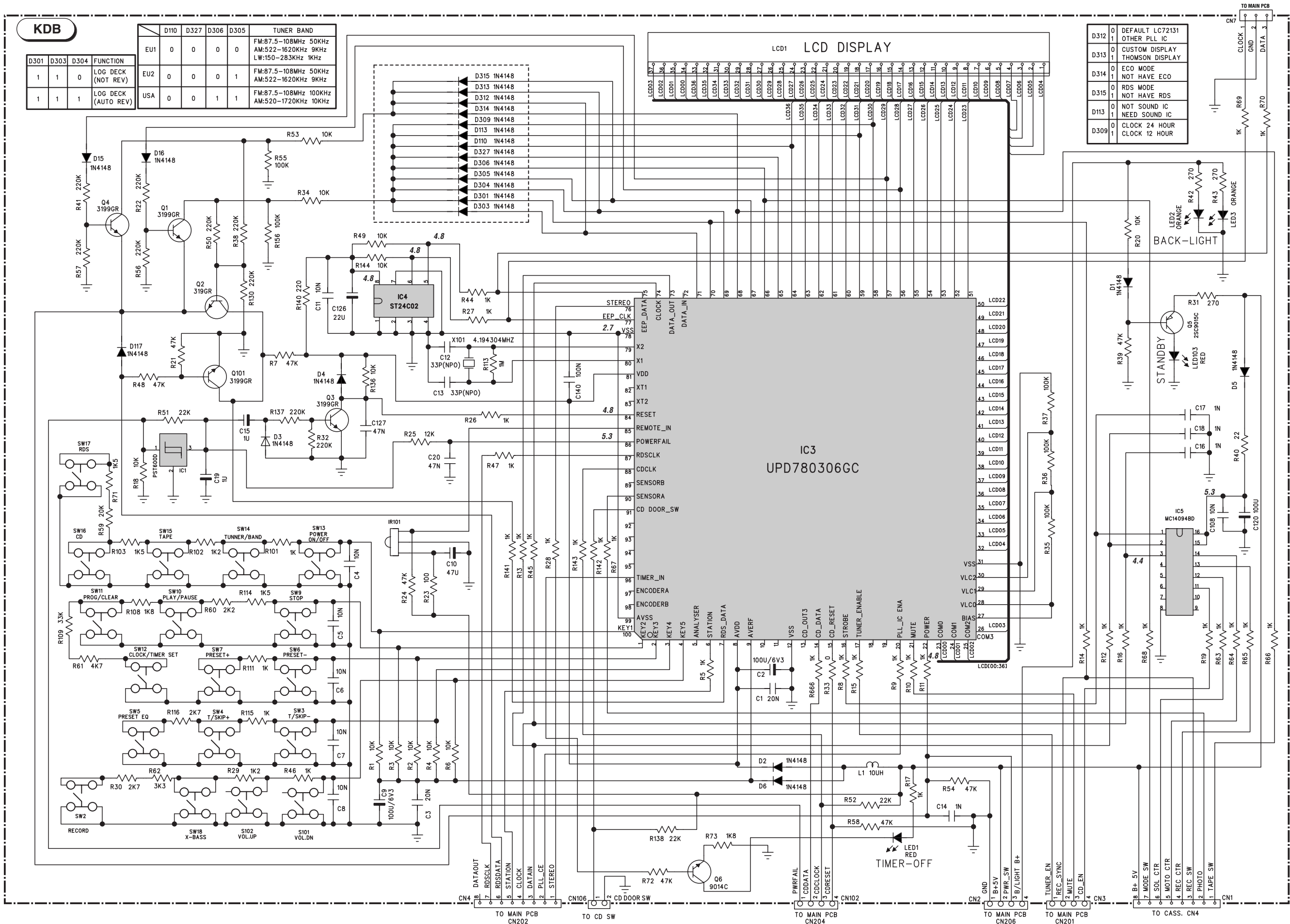

KDB

D301	D303	D304	FUNCTION
1	1	0	LOG DECK (NOT REV)
1	1	1	LOG DECK (AUTO REV)

	D110	D327	D306	D305	TUNER BAND
EU1	0	0	0	0	FM:87.5-108MHz 50KHz AM:522-1620KHz 9KHz LW:150-283KHz 1KHz
EU2	0	0	0	1	FM:87.5-108MHz 50KHz AM:522-1620KHz 9KHz
USA	0	0	1	1	FM:87.5-108MHz 100KHz AM:520-1720KHz 10KHz

D312	0	1	DEFAULT LC72131 OTHER PLL IC
D313	0	1	CUSTOM DISPLAY THOMSON DISPLAY
D314	0	1	ECO MODE NOT HAVE ECO
D315	0	1	RDS MODE NOT HAVE RDS
D113	0	1	NOT SOUND IC NEED SOUND IC
D309	0	1	CLOCK 24 HOUR CLOCK 12 HOUR

Controls / display P.C.B.
 Platine commandes / afficheurs
 Ltpl. Bedienteil / Anzeige
 Piastra comandi / indicatori
 Platina de mandos / indicadores

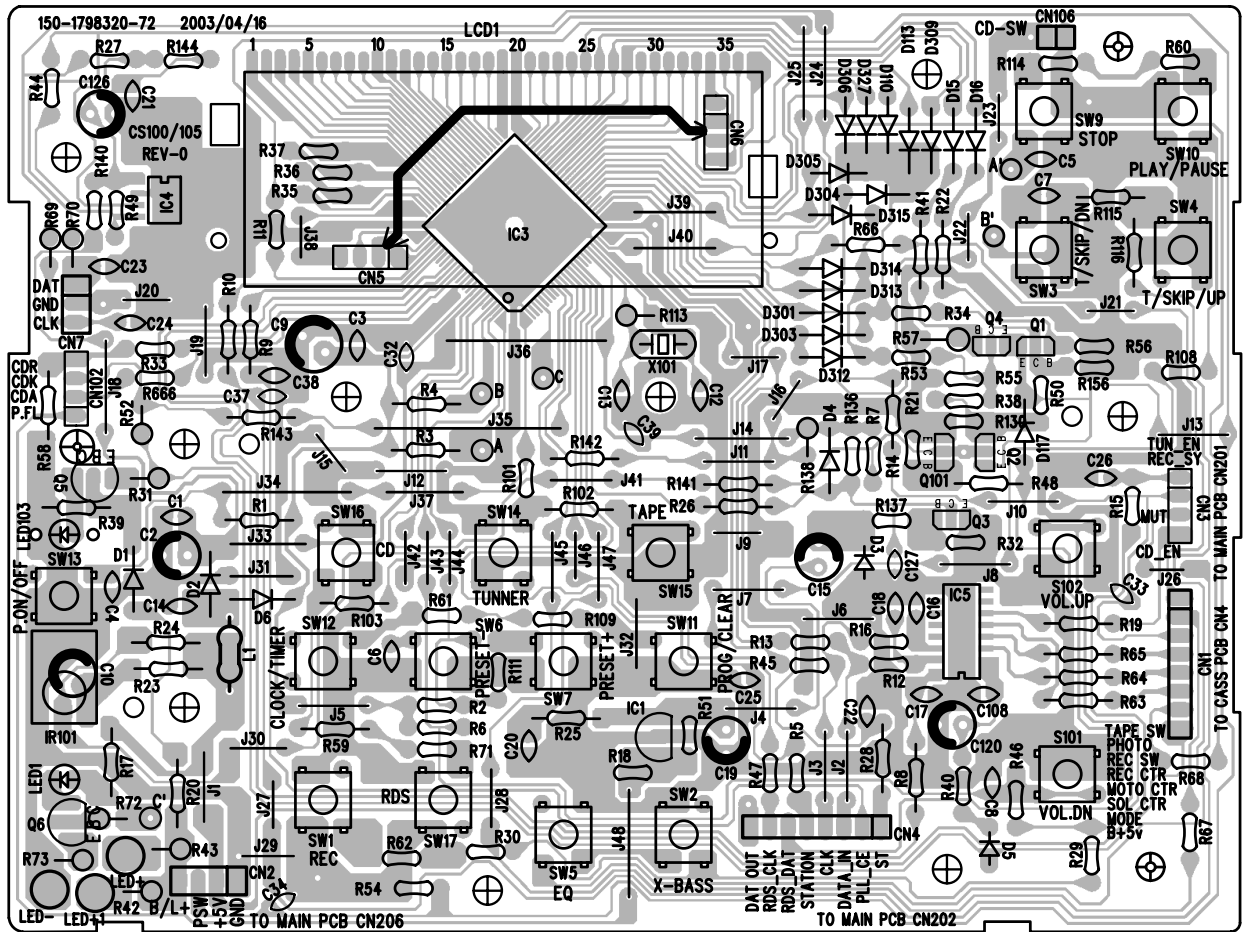

IC4 ST24C02

