

HOW TO USE INTELLIGENT L.C.D.s

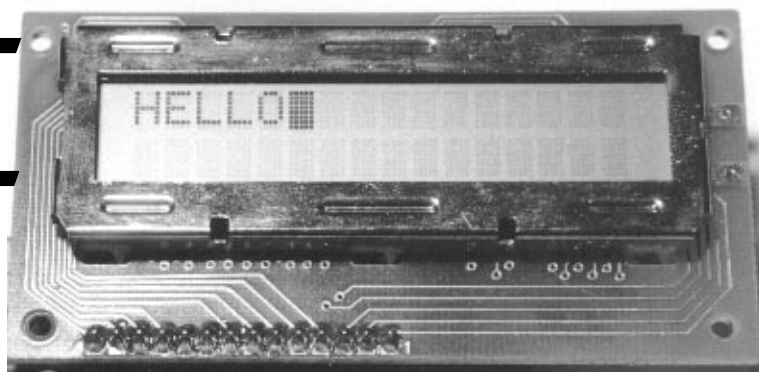

JULYAN ILETT

Part Two

An utterly "practical" guide to interfacing and programming intelligent liquid crystal display modules.

IN THE FIRST part of this article, the capabilities of character-based liquid crystal display (l.c.d.) modules were examined, using a few simple, practical experiments. A series of switches was all that was needed to evaluate the command set in its most fundamental form, in binary (or hexadecimal).

However, in almost all instances where an l.c.d. is to be used in a design, a microprocessor, or more probably a microcontroller, will be needed to drive it. This is the subject we examine now.

GOOD TIMES

The timing requirements of the HD44780 chip, the controlling device used in most character-based l.c.d. modules, are illustrated in Fig. 6. The diagram provides the information for both read and write cycles, although some data sheets may show the two separately. Table 4 details the timing parameters referred to in Fig. 6.

In the experiments last month, commands were sent to the display by pressing switches on an experimental test rig. Nothing much went wrong there, so why is it necessary to have such a complex timing diagram?

Well, we human beings leave plenty of time between pressing one switch and the next, so the l.c.d. controller can easily keep up with us. Microcontrollers are faster than we are, though; they can toggle a control line several million times a second, and at such speeds the l.c.d. controller might not keep pace with the commands.

The timing diagram and its tabulated figures simply tell us how quickly the l.c.d. chip can respond so that we can program the microcontroller accordingly.

Let's take a typical microcontroller, one of the PIC devices which have become so popular, and see how we program it to

control an l.c.d. from the quoted timing details.

First, though, it must be pointed out that the discussions from now assume that you have a rudimentary understanding of programming PIC microcontrollers, and that you have suitable software and equipment for doing so. It is not the intention of this article to teach PIC programming.

(We have published several PIC-based projects in recent month's which are well worth studying, along with their software listings. See the Back Issues and EPE PCB Service pages. Ed.)

The PIC microcontroller would be programmed to start by first setting the l.c.d.'s RS line to its correct logic level. This is the line that determines whether the l.c.d. should regard data as control instructions or character information. In cases where data needs to be read back from the l.c.d.,

the microcontroller must also have control over the R/W line (read/write), otherwise it should be connected to ground, as on the test rig.

The microcontroller can set up these two signals at the same time, or it may do one before the other, it doesn't really matter. What is important, is that they are both "valid" or "stable" for a minimum period of time before the level on the "E" (Enable) line is raised to a logic 1. On the diagram in Fig. 6, this period is shown as "tAS" (time - address setup), and in the table this is specified as 140ns minimum. It can be more than 140ns, but it must not be any less.

Once line E is high, it must not be brought low again until at least 450ns has elapsed, as is indicated by the "tEH" (time - enable high). Also, all eight data lines must be set to their appropriate logic levels and allowed to stabilise for at least the "tDS" (time - data setup) period of 200ns before bringing line E low again.

Note that the l.c.d. allows the data lines to be set up after line E is taken high. In the experiments last month, data was established well before the E switch was pressed, but either condition is allowed.

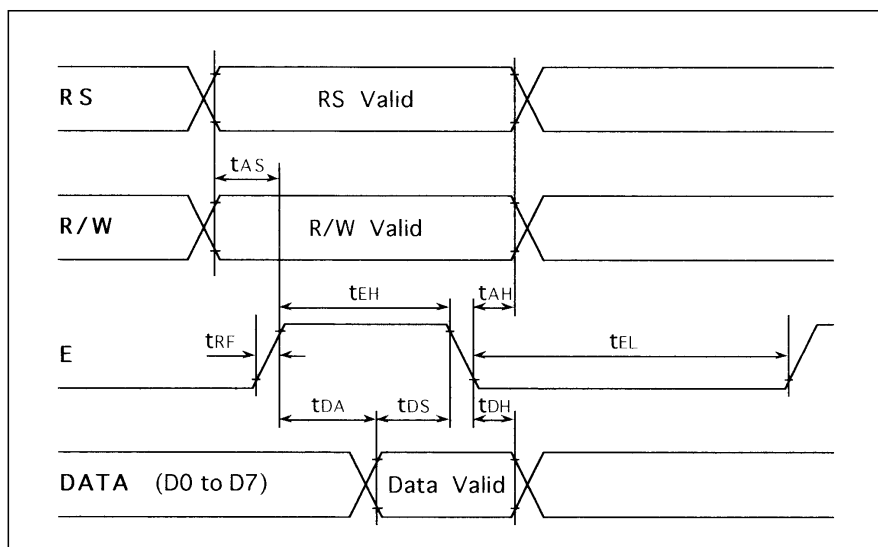

Fig. 6. HD44780 timing diagram.

Table 4. HD44780 Timing Parameters.

Parameter	Description	Time
tAS	Address set up time	140ns min
tAH	Address hold time	10ns min
tDS	Data set up time	200ns min
tDH	Data hold time	20ns min
tDA	Data access time	320ns max
tEH	Enable high time	450ns min
tEL	Enable low time	500ns min
tRF	Rise/Fall time	25ns max

When line E is returned to a low level, there are also two hold times that must be taken into account. The "tAH" (time – address hold) parameter indicates that the RS and R/W lines must not be altered for at least 10ns, and "tDH" (time – data hold) shows that none of the data lines must change for at least 20ns.

One further restriction exists. The E line must not be taken high again (for the next command, that is) for another 500ns (tEL: time – enable low). This means that the total cycle time of the E line is 450ns plus 500ns. Allowing for the rise and fall times, indicated by "tRF", which should be no longer than 25ns each, an approximate value of 1µs can be calculated. This means that no more than one million commands (or one million characters) per second should be sent to the display, not a restriction that would normally present many problems!

BUSY

The timing diagram doesn't tell the whole story, however. Much longer delays are required to enable the l.c.d. to process commands and data. Most commands tie-up the l.c.d. for 40µs,

during which time it is said to be "busy". The Clear Display and Cursor Home commands, though, can take a lot longer.

Execution times for all the instructions are shown in Table 5. This includes all the commands, writing data to the display, and reading both data and status. The two Read instructions have not yet been experimented with, but reading the status of the l.c.d. is the method used to determine whether or not it is busy.

The practical implication of these instruction times is just a case of having to insert a delay between one instruction and the next. The first two commands, Clear Display and Cursor Home, have variable execution times that depend upon several factors. Not much is said about this variation in the data sheets, but it does involve returning the cursor to address 10000000 (\$80), unshifting the display and, in the case of Clear Display, putting a space character into each display address.

Table 5. HD44780 Command Execution Times.

Instruction	Time (Max)
Clear Display	82µs to 1.64ms
Display & Cursor Home	40µs to 1.64ms
Character Entry Mode	40µs
Display On/Off & Cursor	40µs
Display/Cursor Shift	40µs
Function Set	40µs
Set CGRAM Address	40µs
Set Display Address	40µs
Write Data	40µs
Read Data	40µs
Read Status	1µs

There is one other important situation when the l.c.d. will be busy. This is immediately after it has been powered up. It takes some 10 to 15 milliseconds for the full initialisation sequence to be completed, during which time no instructions can be executed.

This has important implications for a circuit using a microcontroller. A suitable delay must be added to the beginning of the program, otherwise the l.c.d. won't be ready when the first few instructions are sent to it and could become locked up in a non-correctable condition, requiring the power to be switched off again for a while.

NEW CIRCUIT

Time now to re-wire last month's experimental test rig to incorporate the PIC microcontroller. The circuit diagram of the modified arrangement is shown in Fig. 7. There's no longer any need for the debounce circuit, the microcontroller provides very clean output signals. It is not essential to use the PIC16C84 type specified in the diagram, the 54, 56, 61 and 71 types can all be used, but some minor changes may need to be made to one or two of the pin connections.

However, it is best to experiment with the PIC16C84 since it is the EEPROM (Electrically Erasable Programmable Read Only Memory) version of the microcontroller.

The use of this version is desirable because several different versions of software will need to be programmed and erased during the course of experimentation. Other versions of the microcontroller cannot be erased so easily, indeed some cannot be erased at all (those referred to as OTP, One-Time Programmable devices, for example).

The microcontroller's Clock Option can be set for RC (resistor/capacitor) or any one of the XT (crystal) options, but the RC option is cheaper, and precise timing accuracy is not important in this instance. The values of the resistor R1 and capacitor C1 connected to the OSC1 input in Fig. 7, will give a clock frequency of very approximately 2MHz. For the time-being, lower values of resistance or capacitance

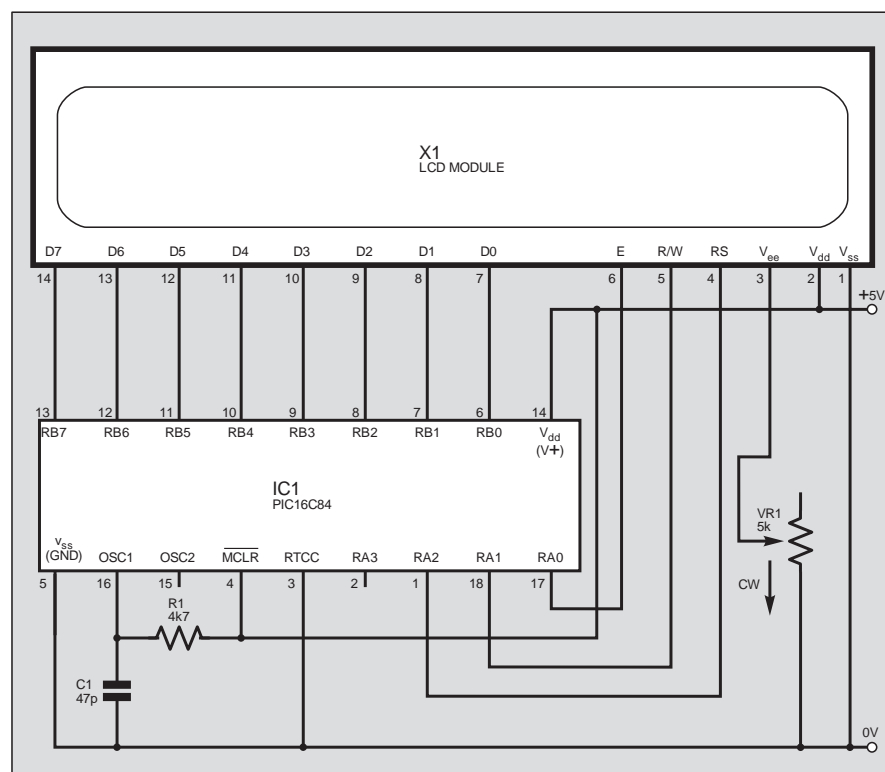

Fig. 7. Circuit diagram for interfacing a PIC16C84 microcontroller to an l.c.d. module.

(for faster speeds) should be avoided, to ensure the software delays are sufficiently long.

EXPERIMENT 8

PIC Program

Compile and program the contents of Listing 1 into the PIC microcontroller. It has been written for use with MPALC assembler software, although it can be readily translated to suit MPASM or TASM assembly.

Once the PIC has been programmed, re-power up the circuit. The word HELLO will appear on the display. There may seem to be a lot of source code required to do such a simple job, but the program performs all the setting up that the display needs, and can form the basis of a more complex system.

Precisely what all these instructions do is important and will be described in some detail.

The first routine, "initialise", comprises five Clear File (clrf) instructions which set the contents of five registers to zero. Two of these registers, 05 and 06, relate to output Ports A and B.

When the microcontroller is powered up, all port pins are automatically set up as inputs, so that no damage is done to external circuitry. The "setports" routine uses "tris" instructions to redefine each bit of Ports A and B as either an input or an output.

(Be aware that Microchip, manufacturers of the PIC family, now discourage the use of "TRIS", a command becoming incompatible with their newer devices. There are alternative ways of achieving the same result, as discussed in the PIC data books. Ed.)

The "longdelay" routine keeps the microcontroller occupied while the l.c.d. is initialising. This delay must be no less than 15ms, but can be more, of course. The routines "functionset" and "displayon" are very similar and issue hexadecimal commands \$38 and \$0F (00111000 and 00001111) to the l.c.d. These numbers should be familiar from the experiments carried out in Part 1.

Both routines contain "call" instructions to two subroutines, "pulse_e" and "shortdelay", which can be seen towards the end of the listing. The "message" routine incorporates a program loop which is executed five times to output the five characters in the text table ("text") to the l.c.d. The PIC uses an unusual type of subroutine, comprising a list of "retlw" (return with literal) instructions which can be used to form tables of data.

Register \$0D is used as a counter which is initially set to zero by the "clrf" instruction in the "initialise" routine. This value is then used as a pointer to the text table which contains the ASCII characters which spell HELLO.

The "stop" routine locks up the microcontroller to stop it doing anything else. Finally, the "end" directive is not a program command, but an instruction to tell the assembler to stop assembling.

A GOOD READ

The program in Listing 1 only writes to the display. In many applications this is quite satisfactory, and it has the advantage of allowing the R/W line on the l.c.d. to

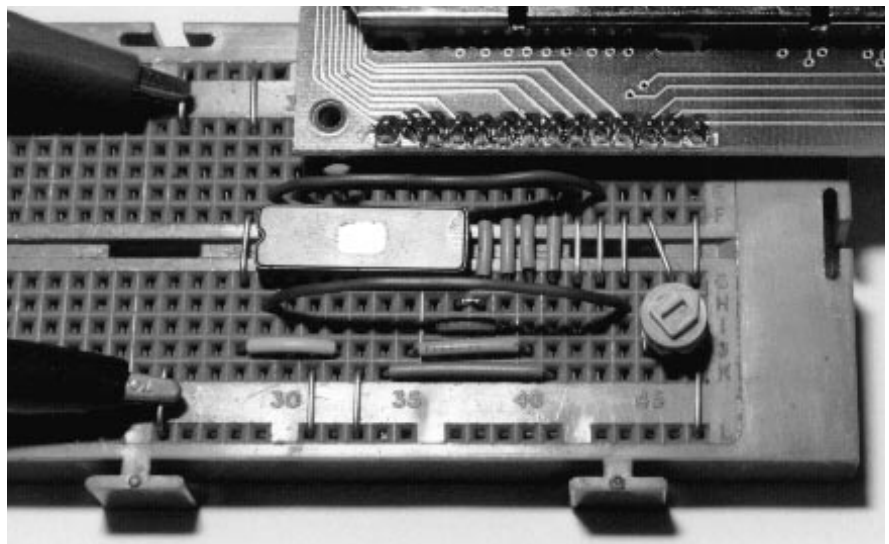

The prototype test rig showing the microcontroller in position (it's actually a PIC16C54, although a PIC16C84 is recommended).

LISTING 1

```

list      p = 16C84                ;tells assembler to generate code for this device
initialise clrf      0D            ;clear register 0D, counter register
           clrf      0E            ;clear register 0E, short delay register
           clrf      0F            ;clear register 0F, long delay register
           clrf      05            ;Port A (register 05) outputs all set to logic 0
           clrf      06            ;Port B (register 06) outputs all set to logic 0
setports  movlw     0F8            ;Port A bits 0, 1, 2 as outputs (E, RS, R/W)
           tris      05
           movlw     00            ;Port B all bits as outputs (D0 to D7)
           tris      06
longdelay call      shortdelay    ;long delay while lcd initialises
           decfsz   0F,f
           goto     longdelay
functionset bcf      05,02        ;RS line to 0 (Port A, bit 2)
           bcf      05,01        ;R/W line to 0 (Port A, bit 1)
           movlw    38            ;Function Set command
           movwf    06            ;put it on the data lines (Port B)
           call     pulse_e       ;pulse the E line high (Port A, bit 0)
           call     shortdelay
displayon  bcf      05,02        ;RS line to 0 (Port A, bit 2)
           bcf      05,01        ;R/W line to 0 (Port A, bit 1)
           movlw    0F            ;Display On/Off & Cursor command
           movwf    06            ;put it on the data lines (Port B)
           call     pulse_e       ;pulse the E line high (Port A, bit 0)
           call     shortdelay
message   clrf      0D            ;set counter register to zero
           movf     0D,w          ;put counter value in W
           call     text         ;get a character from the text table
           bsf      05,02        ;set RS line to 1 (Port A, bit 2)
           bcf      05,01        ;set R/W line to 0 (Port A, bit 1)
           movwf    06            ;put character on the data lines (Port B)
           call     pulse_e       ;pulse the E line high (Port A, bit 0)
           call     shortdelay    ;delay while l.c.d. is busy
           incf     0D,w          ;try incrementing the counter register
           xorlw    05            ;would that make it increase to 5?
           btfsc   03,02        ;set the zero flag in the status register
           goto     stop         ;stop if all characters displayed
           incf     0D,f          ;increment the counter register
           goto     message      ;go back and do the next character
stop      goto     stop         ;stop the program running
;Subroutines and text table
shortdelay decfsz   0E,f          ;delay while l.c.d. is busy
           goto     shortdelay
           retlw    0
pulse_e   bsf      05,00        ;take E line high
           nop                    ;hold it high for one clock cycle
           bcf      05,00        ;take E line low again
           retlw    0
text      addwf    02,f          ;table of characters for message
           retlw    'H'
           retlw    'E'
           retlw    'L'
           retlw    'L'
           retlw    'O'
end

```

Table 6. HD44780 Read Instructions

Instruction	RS	Binary							
		D7	D6	D5	D4	D3	D2	D1	D0
Read data	High	D	D	D	D	D	D	D	D
Read Status	Low	BF	A	A	A	A	A	A	A

D: Character data at current cursor address
A: Current cursor address (\$00 to \$7f)
BF: Busy Flag (0 = Ready, 1 = Busy)

be connected to ground, which in turn saves an I/O (input/output) pin on the microcontroller.

It is possible (and sometimes necessary) to read data and status information from the l.c.d., but of course the R/W line must be actively connected in order to do this. Reading the display differs from writing to it in some fundamental ways, so a re-examination of the timing diagram is now required, as the sequence of events is described.

Lines RS and R/W must be set up first, with R/W being set to a logic 1 this time. If RS is set high, data is returned indicating the character that is at the current cursor address. If RS is set low, a status byte is sent back, containing two separate items, bits 0 to 6 holding the current cursor address, and bit 7 containing the Busy flag.

The two Read instruction formats are shown in Table 6. After the necessary "address setup time" (tAS), the E line can be taken high. This is the point at which the read cycle differs from the write cycle, as the l.c.d.'s data lines will switch over to being outputs.

Clearly, before the microcontroller starts this read cycle, it must change its data lines to inputs, otherwise outputs would be connected to outputs and a fight (known as *bus contention*) would ensue. In any case, if the microcontroller's data lines were not inputs at this time, it would not be able to read the data.

It takes a while for the l.c.d. to change its data lines to outputs, and stabilise the data on them, but it guarantees to do this within 320ns, the "data access time" (tDA). The microcontroller can then read this data in through its inputs, and as soon as it's happy that it's got it, the E line can go back down.

Most of the information that can be read back from the display must have been written there by the microcontroller in the first place, which explains why many designs can get away without having the R/W line connected up.

The Busy flag, though, can be useful to the microcontroller, to avoid using all those delay routines. For applications which need to put a lot of information on the display in a very short time, checking the Busy flag is the most efficient way of knowing when the display is ready.

EXPERIMENT 9

Status Reading

In this experiment, the program in Listing 1 will be altered to incorporate checking of the Busy flag. The plan here is to replace the subroutine "shortdelay",

which has a fixed delay time, with another routine which will constantly check the Busy flag until it isn't busy any more.

Listing 2 shows the new subroutine, called "busywait". All occurrences of the "call shortdelay" instruction in Listing 1 should be replaced by "call busywait", including the three line section headed "longdelay". The program will put the message onto the display much more quickly than before, as unnecessary delays are eliminated.

The first two lines of "busywait" change the assignment of Port B, so that all of its I/O lines become inputs. Following this, the RS and R/W lines are set up ready for the status read. For short delays, the "nop" (no operation) instruction can be used, it is ideal for the small delay times required by the l.c.d. interface.

The E line is then sent high and, after a short delay to allow for the data access time (tDA), the state of the Busy flag is read into the microcontroller. A "rotate left" (rlf) instruction is used here, to transfer the Busy flag on data line D7, into the PIC's Carry flag, where it can be stored prior to testing.

Line E is then taken low, after which a test is performed on the Carry flag using the "btfss" instruction. If the Carry flag is set, then the l.c.d. was busy at the moment the reading was taken, and the program branches back to perform another status read.

If the l.c.d. is found to be no longer busy, Port B is switched back for all bits to be outputs and the subroutine returns to the main program. The program uses more code, but saves time by avoiding unnecessary delays.

LISTING 2

```

busywait    movlw    0FF        ;Port B all inputs (D0 to D7)
            tris     06
            bcf     05,02      ;RS line to 0 (Port A, bit 2)
            bsf     05,01      ;R/W line to 1 (Port A, bit 1)
            nop
            busyread  bsf     05,00 ;raise E line (Port A, bit 0)
            nop
            rlf     06,w       ;rotate BF into Carry flag
            bcf     05,00      ;lower E line (Port A, bit 0)
            nop
            nop
            btfsc   03,00      ;test Carry flag
            goto    busyread   ;if busy, go round again
            movlw   00        ;Port B all outputs (D0 to D7)
            tris    06
            retlw   0         ;return to main program
    
```

LISTING 3

```

functionset bcf     05,02      ;RS line to 0 (Port A, bit 2)
            bcf     05,01      ;R/W line to 0 (Port A, bit 1)
            movlw   20        ;1st Function Set command
            movwf   06        ;put it on the data lines (Port B)
            call    pulse_e   ;pulse the E line high (Port A, bit 0)
            call    busywait
functionset2 bcf     05,02      ;RS line to 0 (Port A, bit 2)
            bcf     05,01      ;R/W line to 0 (Port A, bit 1)
            movlw   28        ;2nd Function Set command
            movwf   0C        ;store command temporarily in 0C
            call    portnibble
            call    pulse_e   ;pulse E line high (Port A, bit 0)
            swapf   0C,w       ;swap nibbles of 0C, put result in W
            call    portnibble
            call    pulse_e   ;pulse E line high (Port A, bit 0)
            call    busywait
;Additional subroutine for nibble mode
portnibble  andlw   0F0        ;clear lower 4 bits of W
            iorwf   06,f       ;OR this with Port B
            iorlw   0F        ;set lower 4 bits of W
            andwf   06,f       ;AND this with Port B
            retlw   0
    
```

EXPERIMENT 10

Nibble Mode

The final experiment is to implement 4-bit data transfer mode between the l.c.d. and the microcontroller. This was examined in Experiment 7 in Part 1, so the technique should be reasonably well understood.

However, several changes need to be made, both to the circuit and to the program, details of which will be left to you to fully implement, but the principles involved are as follows:

Listing 3 shows some of the changes. Data lines D0 to D3 on the l.c.d. should be disconnected from the microcontroller (see Part 1 for how to deal with these unused l.c.d. lines). Data lines D0 to D3 on the microcontroller are now free to be used for other purposes, but for the time being can be left open circuit.

As we saw in Part 1, two separate Function Set commands are needed to set up the l.c.d. First, binary code 00100000 (hexadecimal \$20) is sent while the l.c.d. is still in 8-bit mode, the mode which it automatically adopts when first switched on. This first code is followed by 00101000 (\$28) sent as two separate nibbles, i.e. 0010 and 1000, both sent on lines D4 to D7. (Don't forget that lines RS and E must be dealt with appropriately when sending data.)

In Listing 3, the "functionset" routine of Listing 1 has been modified to send \$20 instead of \$38, and then a new routine, "functionset2", has been added, between "functionset" and "displayon", to send \$2, and then \$8. In the new routine, splitting a command byte into two nibbles is achieved by using the PIC's "swapf" in-

struction, which exchanges the upper and lower halves of any register.

The purpose of using 4-bit mode is that the other four bits of Port B (bits 0 to 3) can be used for something else, so writing data out on the upper half of Port B, must be done in such a way that it does not affect the lower half. In practice, *any* of the microcontroller's data lines can be used to send control the l.c.d., programming the software accordingly.

Individual "bit set" (bsf) or "bit clear" (bcf) instructions could be used to alter each bit in turn, but there is a simpler, more logical way, literally! A sequence of AND and OR instructions can be used to handle all eight bits of Port B, masking out those which must not be changed.

Listing 3 shows a subroutine called "portnibble" which contains a sequence of four instructions that do the job. The upper four bits of the W register are transferred to the upper four bits of Port B, without affecting the lower four bits. A separate "pulse_e" call must be made for each of the two nibbles transferred, after

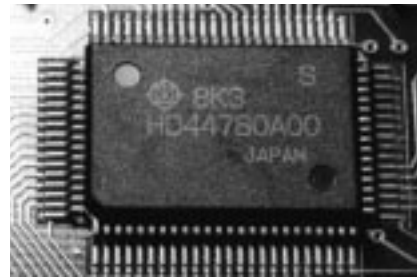

The "intelligent" heart of the l.c.d. modules discussed.

which a single "busywait" call is added.

The "portnibble" routine is added to Listing 1 between the end of the "text" table and the "end" statement.

It is also necessary to alter the "displayon" routine of Listing 1 to operate in 4-bit mode, in the same way as is done in the "functionset2" routine. You can do the conversion for yourself to prove that you have understood so far!

More challenging, perhaps, are the modifications that have to be made to the "message" routine of the program. The procedure is the same, however, two 4-bit transfers being required instead of one 8-bit transfer. The use of 4-bit data transfer mode does add to the complexity of the software, but is well worth the effort as four extra I/O pins are released.

DIGITAL ALTERNATIVES

So many electronic devices, these days, have a small keyboard and a liquid crystal display. For example, many of the better portable radio systems have dispensed with the potentiometer as a volume control, and the variable capacitor as a tuning control, and opted for a digital data entry and display alternative.

The advantages that such digital systems offer are undeniable, and even for the amateur constructor are readily achievable using low-cost but powerful microcontrollers, and inexpensive but versatile displays and keyboards, as the experiments in this two-part series have hopefully suggested to you.

(We have more PIC-controlled l.c.d. orientated projects in the pipeline. Ed.)