

1A Low Dropout Fast Response Positive Adjustable Regulator and Fixed 1.8V, 2.5V, 2.85V and 3.3V

Features

- Guaranteed Output Voltage Accuracy within 2%
- Fast Transient Response
- Guaranteed Dropout Voltage at Multiple Currents
- Load Regulation : 0.1% Typ.
- Line Regulation : 0.03% Typ.
- Low Dropout Voltage : 1.1V Typ. at $I_{OUT} = 1A$
- Current Limit : 1A Typ. at $T_j = 25^\circ C$
- On-Chip Thermal Limiting : $150^\circ C$ Typ.
- Adjustable Output : 1.25~10.7V
- Standard 3-pin TO-220, TO-252, TO-263 and SOT-223 Power Packages

General Description

The APL1117 is a low dropout three-terminal adjustable regulators with 1A output current capability. In order to obtain lower dropout voltage and faster transient response, which is critical for low voltage applications, the APL1117 has been optimized. The device is available in an adjustable version and fixed output voltages of 1.8V, 2.5V, 2.85V and 3.3V. The output available voltage range of an adjustable version is from 1.25~10.7V with an input supply below 12V. Dropout voltage is guaranteed at a maximum of 1.3V at 1A. Current limit is trimmed to ensure specified output current and controlled short-circuit current. On-chip thermal limiting provides protection against any combination of overload that would create excessive junction temperatures. The APL1117 is available in the industry standard 3-pin TO-220, TO-252, TO-263, and the low profile surface mount SOT-223 power packages which can be used in applications where space is limited.

Applications

- Active SCSI Terminators
- Low Voltage Logic Supplies
- Battery-Powered Circuitry
- Post Regulator for Switching Power Supply

Pin Description

Front View for TO-220

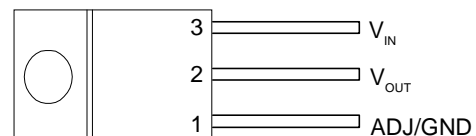

Front View for TO-263

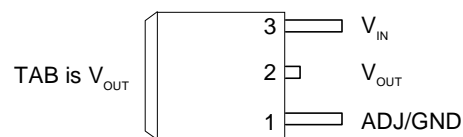

Front View for TO-252

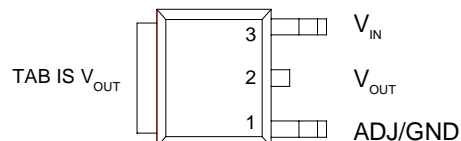







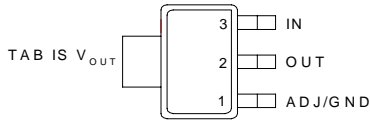

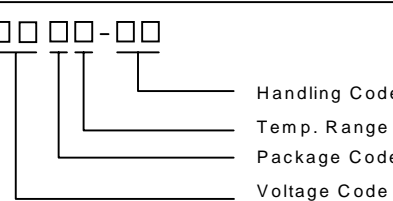

ANPEC reserves the right to make changes to improve reliability or manufacturability without notice, and advise customers to obtain the latest version of relevant information to verify before placing orders.

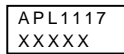
Pin Description (Cont.)

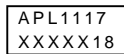
Front View for SOT-223

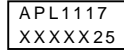

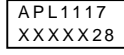
Ordering and Marking Information

APL1117- □□ □□ - □□ 	Package Code F : TO-220 G : TO-263 U : TO-252 V : SOT-223 Temp. Range C : 0 to 70 °C Handling Code TU : Tube TR : Tape & Reel Voltage Code 18 : 1.8V 25 : 2.5V 28 : 2.85V 33 : 3.3V Blank : Adjustable Version
APL1117 F/G/U :  XXXXX - Date Code	APL1117 V :  XXXXX - Date Code
APL1117-18F/G/U :  XXXXX - Date Code	APL1117-18V :  XXXXX - Date Code
APL1117-25F/G/U :  XXXXX - Date Code	APL1117-25V :  XXXXX - Date Code
APL1117-28F/G/U :  XXXXX - Date Code	APL1117-28V :  XXXXX - Date Code
APL1117 -33F/G/U :  XXXXX - Date Code	APL1117-33V :  XXXXX - Date Code

Absolute Maximum Ratings

Symbol	Parameter	Rating ^(Note)	Unit
V_i	Input Voltage	15	V
		9	
T_J	Operating Junction Temperature Range		°C
	Control Section Power Transistor	0 to 125 0 to 150	
T_{STG}	Storage Temperature Range	-65 to +150	°C
T_L	Lead Temperature (Soldering, 10 second)	260	°C

Note : The values here show the absolute maximum rating, and for normal usage please refer the test condition in Electrical Characteristics Table.

Electrical Characteristics (Cont.)

Symbol	Parameter	Test Conditions	APL1117			Unit
			Min.	Typ.	Max.	
V_{REF}	Reference Voltage	$10mA \leq I_{OUT} \leq 1A$, $1.4V \leq (V_{IN} - V_{OUT}) \leq 10.75V$, $T_J = 0 \sim 125^\circ C$	1.225	1.250	1.275	V
V_{OUT}	Output Voltage					
	APL1117-18	$T_J = 0 \sim 125^\circ C$, $0 \leq I_{OUT} \leq 1.5A$, $3.5V \leq V_{IN} \leq 9V$,	1.764	1.800	1.836	V
	APL1117-25	$T_J = 0 \sim 125^\circ C$, $0 \leq I_{OUT} \leq 1A$, $4V \leq V_{IN} \leq 9V$,	2.450	2.500	2.550	
	APL1117-28	$T_J = 0 \sim 125^\circ C$, $0 \leq I_{OUT} \leq 1A$, $4.25V \leq V_{IN} \leq 9V$,	2.790	2.850	2.910	
	APL1117-33	$T_J = 0 \sim 125^\circ C$, $0 \leq I_{OUT} \leq 1A$, $4.75V \leq V_{IN} \leq 12V$,	3.235	3.300	3.365	
REG_{LINE}	Line Regulation					
	APL1117	$I_{OUT} = 10mA$, $1.5V \leq (V_{IN} - V_{OUT}) \leq 10.75V$ (Note1)		0.03	0.2	%
	APL1117-18	$I_{OUT} = 0A$, $3.5V \leq V_{IN} \leq 9V$ (Note1)		1	6	mV
	APL1117-25	$I_{OUT} = 0A$, $4V \leq V_{IN} \leq 5.5V$ (Note1)		1	6	
	APL1117-28	$I_{OUT} = 0A$, $4.25V \leq V_{IN} \leq 5.15V$ (Note1)		1	6	
	APL1117-33	$I_{OUT} = 0A$, $4.75V \leq V_{IN} \leq 7.75V$ (Note1)		1	6	
REG_{LOAD}	Load Regulation					
	APL1117	$(V_{IN} - V_{OUT}) = 3V$, $0 \leq I_{OUT} \leq 1A$ (Note1)		0.1	0.4	%
	APL1117-18	$V_{IN} = 3.5V$, $0 \leq I_{OUT} \leq 1A$ (Note1)		1	10	mV
	APL1117-25	$V_{IN} = 4V$, $0 \leq I_{OUT} \leq 1A$ (Note1)		1	10	
	APL1117-28	$V_{IN} = 4.25V$, $0 \leq I_{OUT} \leq 1A$ (Note1)		1	10	
	APL1117-33	$V_{IN} = 4.75V$, $0 \leq I_{OUT} \leq 1A$ (Note1)		1	10	
V_D	Dropout Voltage					
		$I_{OUT} = 100mA$ (Note2)		1	1.1	V
		$I_{OUT} = 500mA$ (Note2)		1.05	1.2	
		$I_{OUT} = 1A$ (Note2)		1.1	1.3	
I_{LIMIT}	Current Limit	$(V_{IN} - V_{OUT}) = 5V$, $T_J = 25^\circ C$	1000			mA
I_{ADJ}	Adjust Pin Current	$(V_{IN} - V_{OUT}) = 3V$, $I_{OUT} = 10mA$		60	120	μA
	APL1117					
ΔI_{ADJ}	Adjust Pin Current Change	$10mA \leq I_{OUT} \leq 1A$, $1.4V \leq (V_{IN} - V_{OUT}) \leq 10.75V$		0.2	5	μA
I_O	Minimum Load Current	$(V_{IN} - V_{OUT}) = 10.75V$ (Note3)		1.7		mA
	APL1117					
PSRR	Ripple Rejection	$f_{RIPPLE} = 120Hz$, $V_{RIPPLE} = 1V_{P-P}$, $(V_{IN} - V_{OUT}) = 3V$	60	75		dB
T_R	Thermal Regulation	$T_J = 25^\circ C$, 30ms Pulse		0.01	0.02	%/W
T_S	Temperature Stability			0.5		%
L_S	Long -Term Stability	$T_J = 125^\circ C$, 1000Hrs.		0.3		%

Electrical Characteristics (Cont.)

Symbol	Parameter	Test Conditions	APL1117			Unit
			Min.	Typ.	Max.	
V_N	RMS Output Noise	$T_J=25^{\circ}\text{C}, 10\text{Hz} \leq F \leq 10\text{kHz}, (\% \text{ of } V_{\text{OUT}})$		0.003		%
θ_{th}	Thermal Resistance	Junction to Case, at Tab Junction to Ambient		15 50		$^{\circ}\text{C}/\text{W}$
OT	Over Temperature Point			150		$^{\circ}\text{C}$
I_Q	Quiescent Current					
	APL1117-18	$V_{\text{IN}} \leq 9\text{V}$		5.5	10	mA
	APL1117-25	$V_{\text{IN}} \leq 9\text{V}$		5.5	10	
	APL1117-28	$V_{\text{IN}} \leq 9\text{V}$		5.5	10	
	APL1117-33	$V_{\text{IN}} \leq 12\text{V}$		5.5	10	

Note 1 : See thermal regulation specifications for changes in output voltage due to heating effects. Load line regulations are measured at a constant junction temperature by low duty cycle pulse testing.

Note 2 : Dropout voltage is specified over the full output current range of the device. Dropout voltage is defined as the minimum input/output differential measured at the specified output current. Test points and limits are also shown on the Dropout Voltage curve.

Note 3 : Minimum load current is defined as the minimum output current required to maintain regulation.

Application Circuits

1.25V to 10.7V Adjustable Regulator

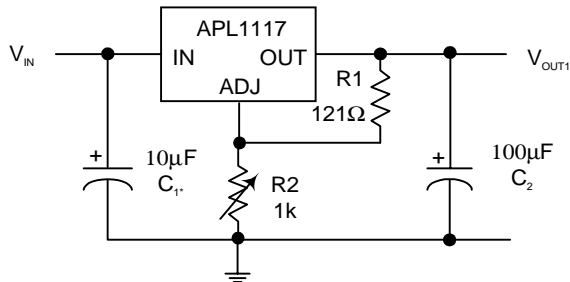

* Needed if device is far from filter capacitors

$$V_{OUT} = 1.250V \times \frac{R1 + R2}{R1}$$

5V Regulator with Shutdown

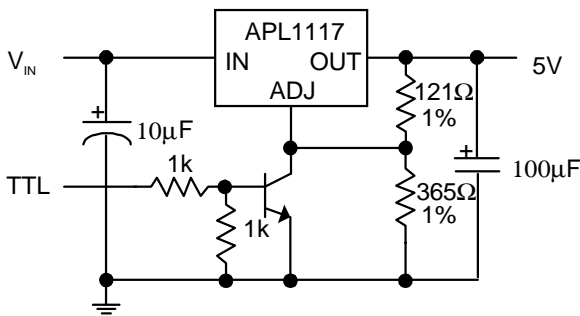

Improving Ripple Rejection

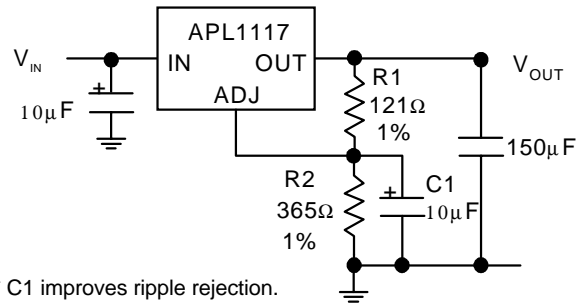

* C1 improves ripple rejection.
X_C should be approximately equal to R1 at ripple frequency

Typical Characteristics

Load Transient Response

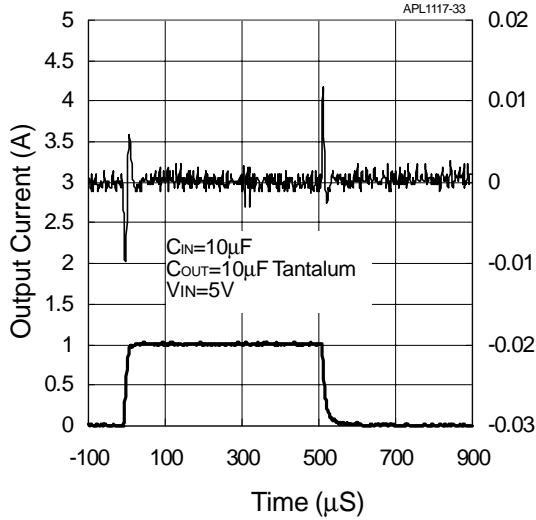

Line Transient Response

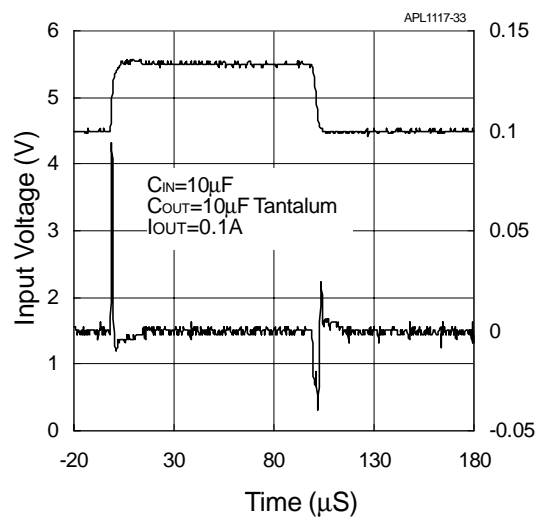

Dropout Voltage vs. Output Current

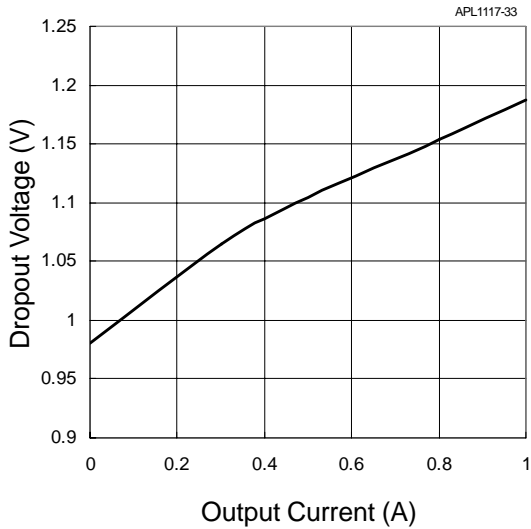

Output Voltage vs. Input Voltage

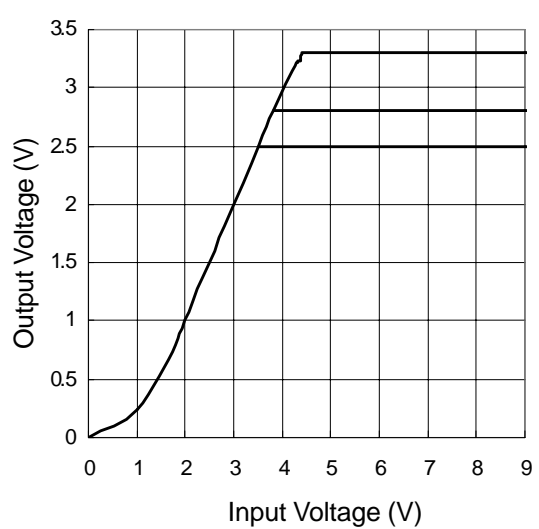

Typical Characteristics Cont.

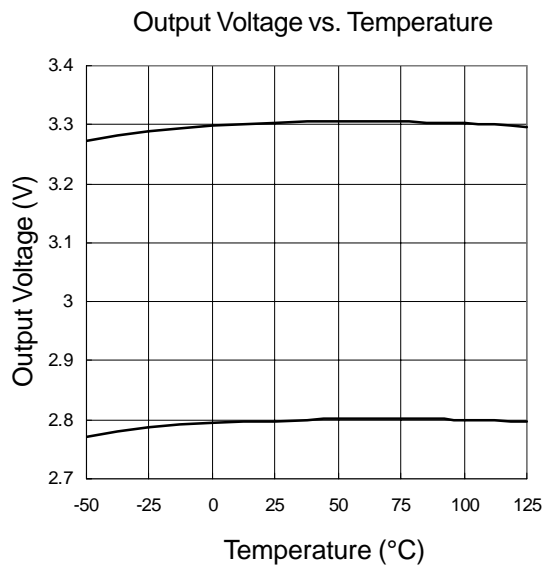
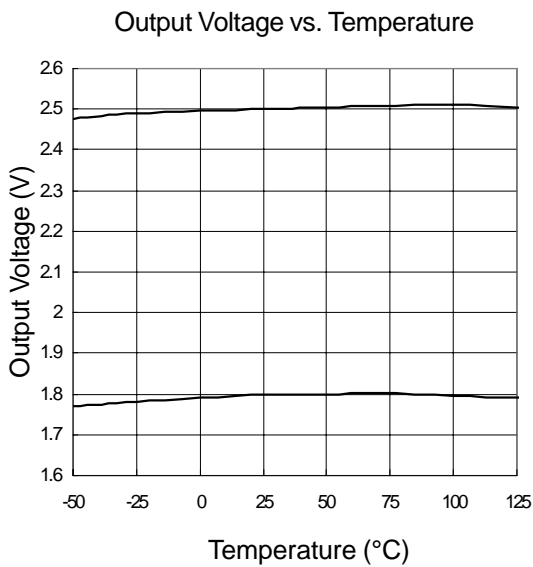
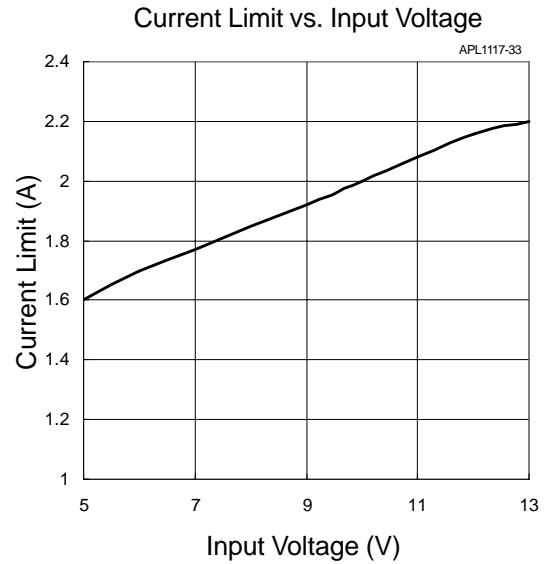
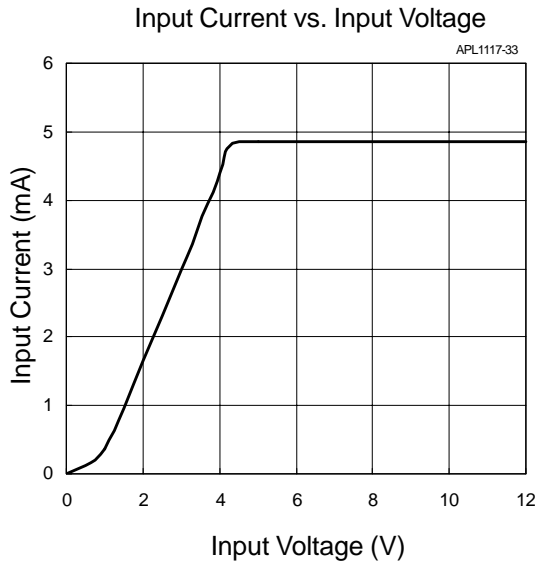

Typical Characteristics Cont.

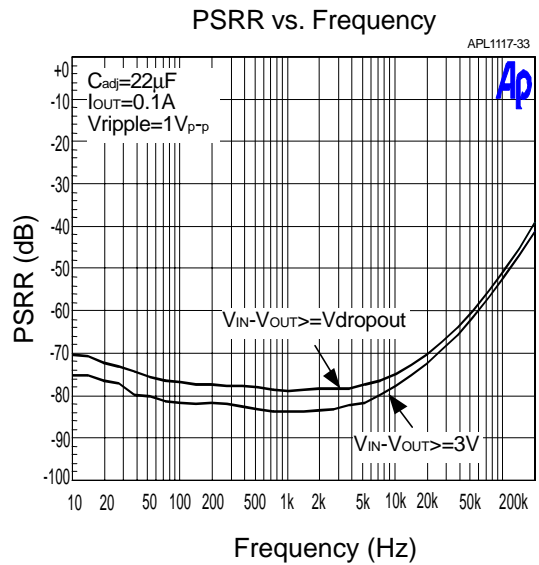
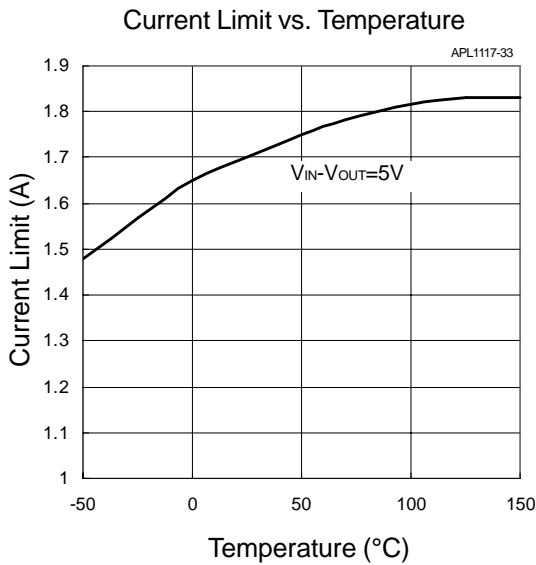
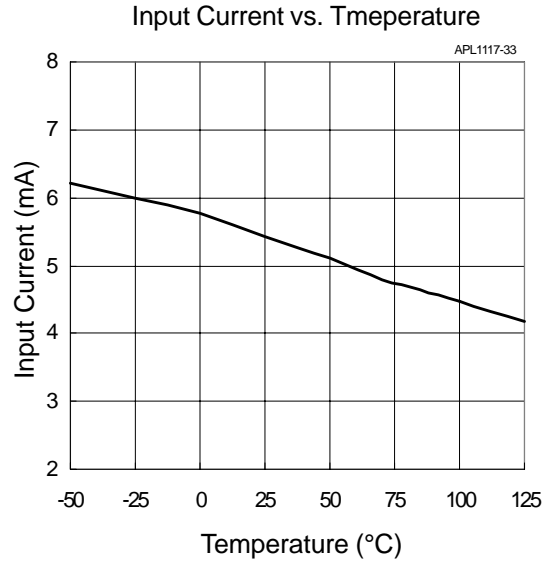
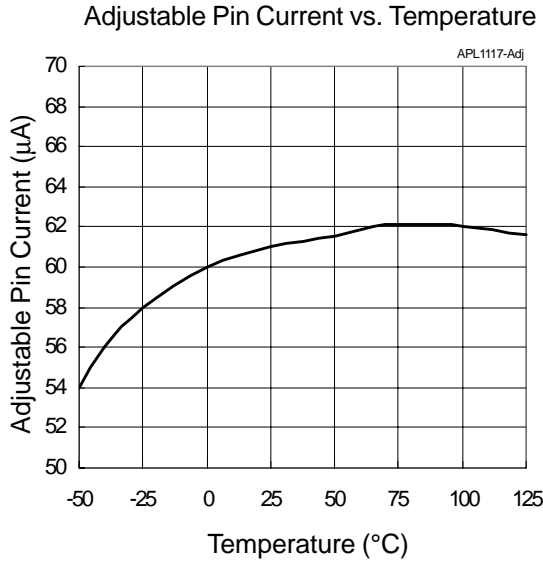

Application Information

Output Voltage

The APL1117 develops a 1.25V reference voltage between the output and the adjust terminal. By placing a resistor between these two terminals, a constant Current is caused to flow through R1 and down through R2 to set the overall output voltage. Normally this current is chosen to be the specified minimum load current of 10mA. For fixed voltage devices R1 and R2 are included in the device.

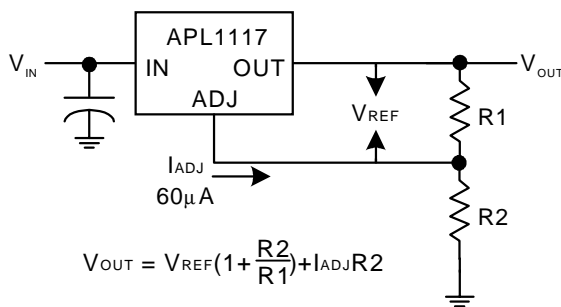

Figure 1. Basic Adjustable Regulator

Load Regulation

When the adjustable regulator is used. Load regulation will be limited by the resistance of the wire connecting the regulator to the load. The data sheet specification for load regulation is measured at the output pin of the device. Best load regulation is obtained when the top of the resistor divider (R1) is tied directly to the output pin of the device, not to the load. For fixed voltage devices the top of R1 is internally connected to the output, and the ground pin can be connected to low side of the load. If R1 were connected to the load, R_p is multiplied by the divider ratio, the effective resistance between the regulator and the load would be:

$$R_p \times \left(1 + \frac{R_2}{R_1}\right), R_p = \text{Parasitic Line Resistance}$$

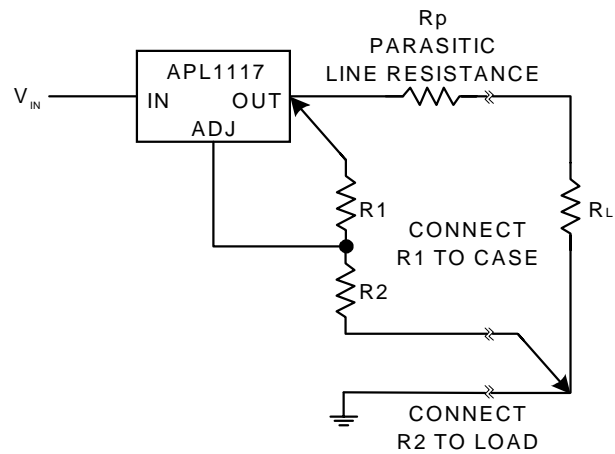

Figure 2. Connections for Best Load Regulation

Input Capacitor

An input capacitor of 10µF or greater is recommended. Tantalum, or aluminum electrolytic capacitors can be used for bypassing. Larger values will improve ripple rejection by bypassing the input to the regulator.

Output Capacitor

The APL1117 requires an output capacitor to maintain stability and improve transient response. Proper capacitor selection is important to ensure proper operation. The APL1117 output capacitor selection is dependent upon the ESR (equivalent series resistance) of the output capacitor to maintain stability. When the output capacitor is 10uF or greater, the output capacitor should have an ESR less than 1Ω. This will improve transient response as well as promote stability. A low-ESR solid tantalum capacitor works extremely well and provides good transient response and stability over temperature.

Application Information (Cont.)

Output Capacitor (Cont.)

Aluminum electrolytics can also be used, as long as the ESR of the capacitor is $<1\Omega$. The value of the output capacitor can be increased without limit. Higher capacitance values help to improve transient response and ripple rejection and reduce output noise.

Ripple Rejection

The curves for Ripple Rejection were generated using an adjustable device with the adjust pin bypassed. With a $22\mu\text{F}$ bypassing capacitor 75dB ripple rejection is obtainable at any output level. The impedance of the adjust pin capacitor, at the ripple frequency, should be $< R1$. $R1$ is normally in the range of 100Ω - 200Ω . The size of the required adjust pin capacitor is a function of the input ripple frequency. At 120Hz, with $R1=100\Omega$, the adjust pin capacitor should be $13\mu\text{F}$. For fixed voltage devices, and adjustable devices without an adjust pin capacitor, the output ripple will increase as the ratio of the output voltage to the reference voltage ($V_{\text{OUT}}/V_{\text{REF}}$).

Thermal Considerations

APL1117 has thermal protection which limits junction temperature to 150°C . However, device functionality is only guaranteed to a maximum junction temperature of $+125^\circ\text{C}$.

Both the TO-220, TO-252, TO-263 and SOT-223 packages use a copper plane on the PCB and the PCB itself as a heatsink. To optimize the heat sinking ability of the plane and PCB, solder the tab of the package to the plane.

Figure 3&4 shows for the TO-252 and SOT-223 the measured values of $\theta(J-A)$ for different copper area sizes using a 2 layers, 1.6mm, and 6Sq. cm FR-4 PCB with 2oz. copper and a ground plane layer on the backside area used for heatsinking. It can be used as a rough guideline in estimating thermal resistance.

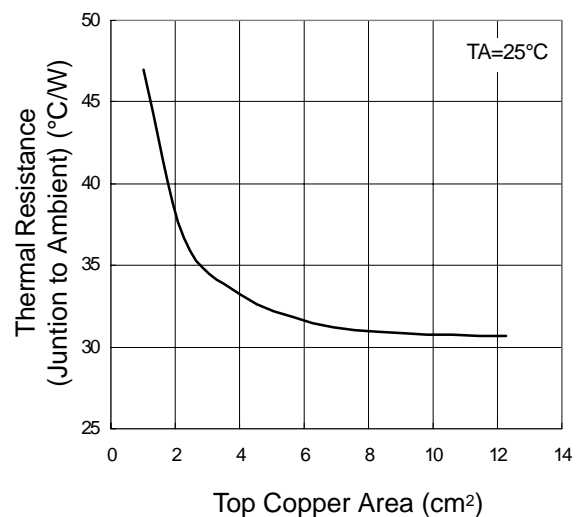

Figure 3.

$\theta(J-A)$ vs. copper area for the SOT-252 package

Application Information (Cont.)

Thermal Considerations (Cont.)

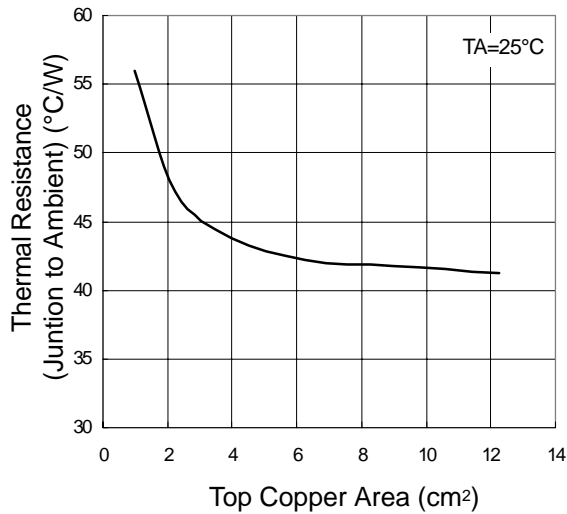

Figure 4.

$\theta(J-A)$ vs. copper area for the SOT-223 package

The thermal resistance for each application will be affected by thermal interactions with other components on the board. Some experimentation will be necessary to determine the actual value.

The power dissipation of APL1117 is equal to :

$$P_D = (V_{IN} - V_{OUT}) \times I_{OUT}$$

Maximum junction temperature is equal to :

$$T_{JUNCTION} = T_{AMBIENT} + (P_D \times \theta_{JA})$$

Note: $T_{JUNCTION}$ must not exceed 125°C

Package Information

TO-220 (Reference JEDEC Registration TO-220)

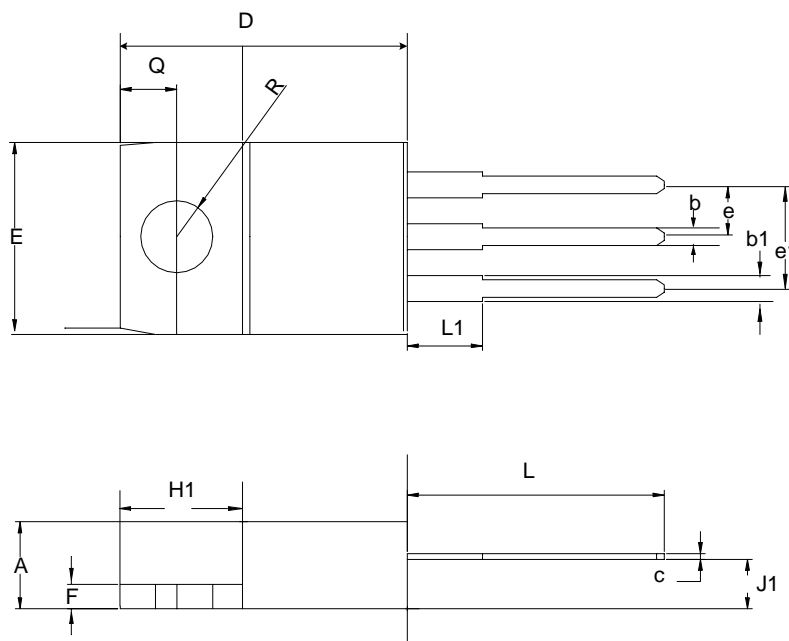

Dim	Millimeters		Inches	
	Min.	Max.	Min.	Max.
A	3.56	4.83	0.140	0.190
b1	1.14	1.78	0.045	0.070
b	0.51	1.14	0.020	0.045
c	0.31	1.14	0.012	0.045
D	14.23	16.51	0.560	0.650
e	2.29	2.79	0.090	0.110
e1	4.83	5.33	0.190	0.210
E	9.65	10.67	0.380	0.420
F	0.51	1.40	0.020	0.055
H1	5.84	6.86	0.230	0.270
J1	2.03	2.92	0.080	0.115
L	12.7	14.73	0.500	0.580
L1	3.65	6.35	0.143	0.250
R	3.53	4.09	0.139	0.161
Q	2.54	3.43	0.100	0.135

Package Informaion

TO-252(Reference JEDEC Registration TO-252)

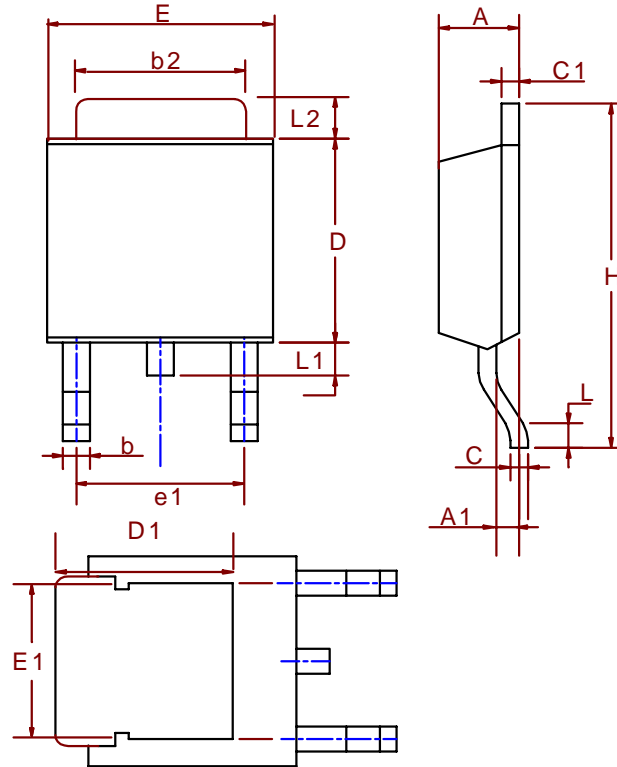

Dim	Millimeters		Inches	
	Min.	Max.	Min.	Max.
A	2.18	2.39	0.086	0.094
A1	0.89	1.27	0.035	0.050
b	0.508	0.89	0.020	0.035
b2	5.207	5.461	0.205	0.215
C	0.46	0.58	0.018	0.023
C1	0.46	0.58	0.018	0.023
D	5.334	6.22	0.210	0.245
D1	5.2 REF		0.205 REF	
E	6.35	6.73	0.250	0.265
E1	5.3 REF		0.209 REF	
e1	3.96	5.18	0.156	0.204
H	9.398	10.41	0.370	0.410
L	0.51		0.020	
L1	0.64	1.02	0.025	0.040
L2	0.89	2.032	0.035	0.080

Package Information

TO-263 (Reference JEDEC Registration TO-263)

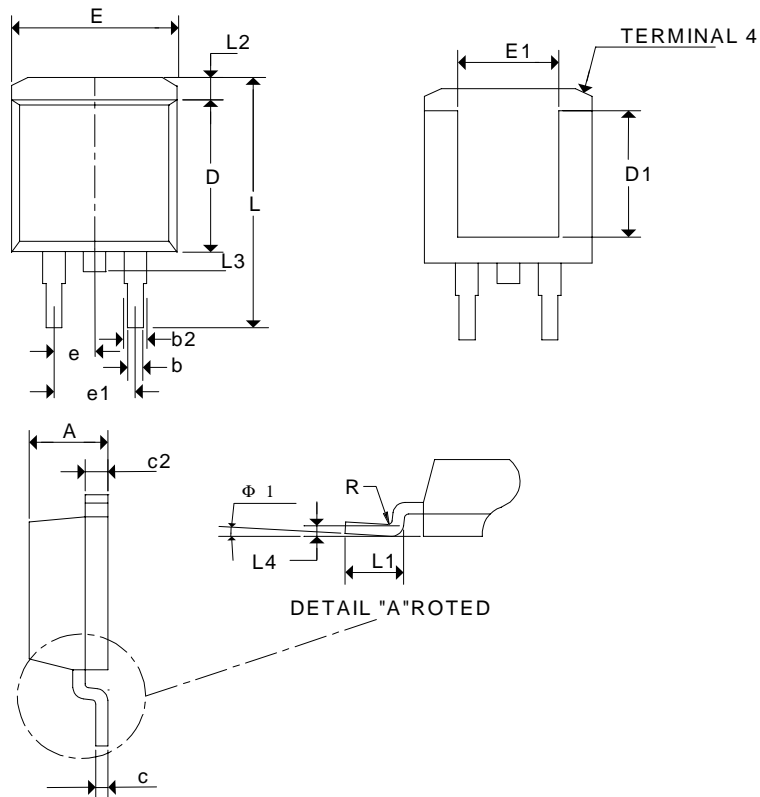

Dim	Millimeters		Inches	
	Min.	Max.	Min.	Max.
A	4.06	4.83	0.160	0.190
b	0.51	1.016	0.02	0.040
b2	1.14	1.651	0.045	0.065
c	0.38 TYP.		0.015 TYP.	
c2	1.14	1.40	0.045	0.055
D	8.64	9.65	0.340	0.380
e	9.65	10.54	0.380	0.415
e1	2.54 TYP		0.100 TYP	
L	14.60	15.88	0.575	0.625
L1	2.24	2.84	0.090	0.110
L2	1.02	2.92	0.040	0.112
L3	1.20	1.78	0.050	0.070

Package Information

SOT-223(Reference JEDEC Registration SOT-223)

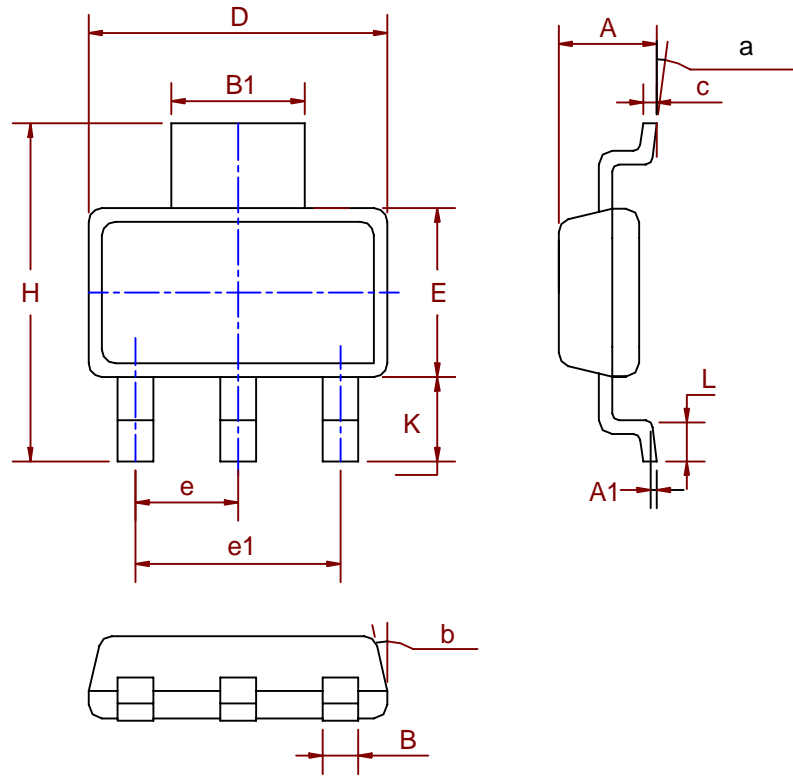

Dim	Millimeters		Inches	
	Min.	Max.	Min.	Max.
A	1.50	1.80	0.06	0.07
A1	0.02	0.08		
B	0.60	0.80	0.02	0.03
B1	2.90	3.10	0.11	0.12
c	0.28	0.32	0.01	0.01
D	6.30	6.70	0.25	0.26
E	3.30	3.70	0.13	0.15
e	2.3 BSC		0.09 BSC	
e1	4.6 BSC		0.18 BSC	
H	6.70	7.30	0.26	0.29
L	0.91	1.10	0.04	0.04
K	1.50	2.00	0.06	0.08
α	0°	10°	0°	10°
β	13°		13°	

Physical Specifications

Terminal Material	Solder-Plated Copper (Solder Material : 90/10 or 63/37 SnPb)
Lead Solderability	Meets EIA Specification RSI86-91, ANSI/J-STD-002 Category 3.
Packaging	2500 devices per reel

Reflow Condition (IR/Convection or VPR Reflow)

Reference JEDEC Standard J-STD-020A APRIL 1999

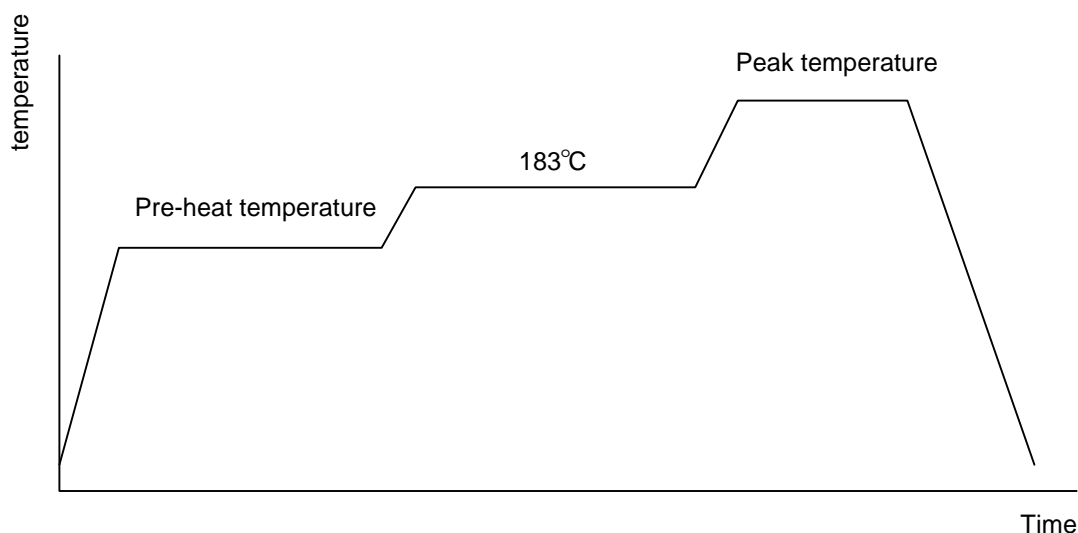

Classification Reflow Profiles

	Convection or IR/ Convection	VPR
Average ramp-up rate(183 °C to Peak)	3 °C/second max.	10 °C /second max.
Preheat temperature 125 ± 25 °C)	120 seconds max.	
Temperature maintained above 183 °C	60 ~ 150 seconds	
Time within 5 °C of actual peak temperature	10 ~ 20 seconds	60 seconds
Peak temperature range	220 +5/-0 °C or 235 +5/-0 °C	215~ 219 °C or 235 +5/-0 °C
Ramp-down rate	6 °C /second max.	10 °C /second max.
Time 25 °C to peak temperature	6 minutes max.	

Package Reflow Conditions

pkg. thickness ≥ 2.5mm and all bags	pkg. thickness < 2.5mm and pkg. volume ≥ 350 mm	pkg. thickness < 2.5mm and pkg. volume <
Convection 220 +5/-0 °C		Convection 235 +5/-0 °C
VPR 215-219 °C		VPR 235 +5/-0 °C
IR/Convection 220 +5/-0 °C		IR/Convection 235 +5/-0 °C

Reliability test program

Test item	Method	Description
SOLDERABILITY	MIL-STD-883D-2003	245°C , 5 SEC
HOLT	MIL-STD-883D-1005.7	1000 Hrs Bias @ 125 °C
PCT	JESD-22-B, A102	168 Hrs, 100 % RH , 121°C
TST	MIL-STD-883D-1011.9	-65°C ~ 150°C, 200 Cycles
ESD	MIL-STD-883D-3015.7	VHBM > 2KV, VMM > 200V
Latch-Up	JESD 78	10ms , I _{tr} > 100mA

Carrier Tape & Reel Dimension

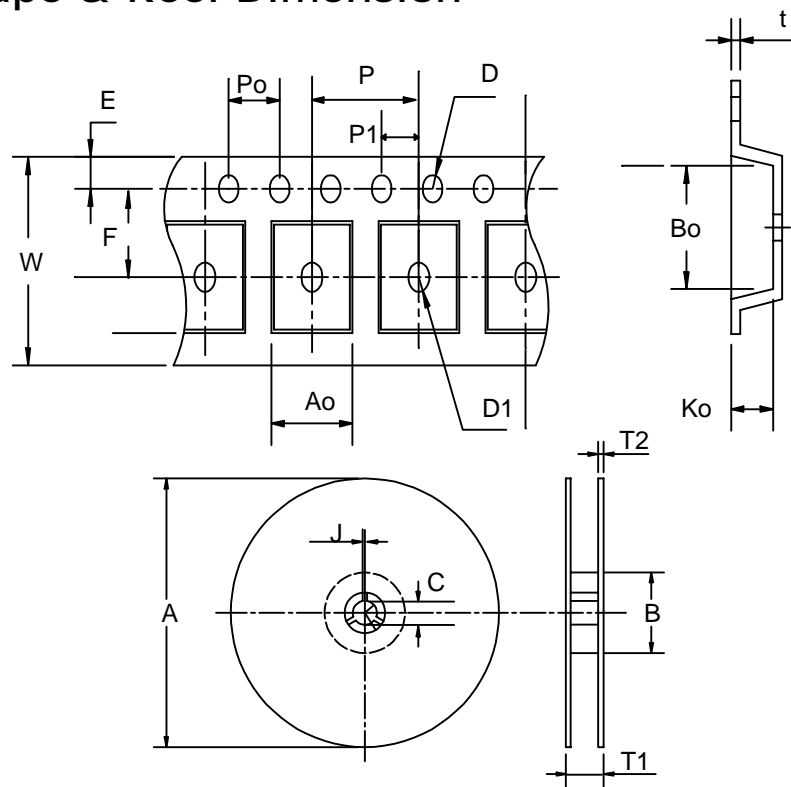

Application	A	B	C	J	T ₁	T ₂	W	P	E
TO-252	330 ± 3	100 ± 2	13 ± 0.5	2 ± 0.5	16.4 + ^{0.3} / _{-0.2}	2.5 ± 0.5	16 + ^{0.3} / _{-0.1}	8 ± 0.1	1.75 ± 0.1
	F	D	D ₁	P ₀	P ₁	A ₀	B ₀	K ₀	t
	7.5 ± 0.1	1.5 + 0.1	1.5 ± 0.25	4.0 ± 0.1	2.0 ± 0.1	6.8 ± 0.1	10.4 ± 0.1	2.5 ± 0.1	0.3 ± 0.05
Application	A	B	C	J	T ₁	T ₂	W	P	E
TO-263	380 ± 3	80 ± 2	13 ± 0.5	2 ± 0.5	24 ± 4	2 ± 0.3	24 + ^{0.3} / _{-0.1}	16 ± 0.1	1.75 ± 0.1
	F	D	D ₁	P ₀	P ₁	A ₀	B ₀	K ₀	t
	11.5 ± 0.1	1.5 + 0.1	1.5 ± 0.25	4.0 ± 0.1	2.0 ± 0.1	10.8 ± 0.1	16.1 ± 0.1	5.2 ± 0.1	0.35 ± ^{0.01} / ₃
Application	A	B	C	J	T ₁	T ₂	W	P	E
SOT-223	330 ± 1	62 ± 1.5	12.75 ± ^{0.15}	2 ± 0.6	12.4 + 0.2	2 ± 0.2	12 ± 0.3	8 ± 0.1	1.75 ± 0.1
	F	D	D ₁	P ₀	P ₁	A ₀	B ₀	K ₀	t
	5.5 ± 0.05	1.5 + 0.1	1.5 + 0.1	4.0 ± 0.1	2.0 ± 0.05	6.9 ± 0.1	7.5 ± 0.1	2.1 ± 0.1	0.3 ± 0.05

Cover Tape Dimensions

Application	Carrier Width	Cover Tape Width	Devices Per Reel
TO- 252	16	13.3	2500
TO- 263	24	21.3	1000
SOT- 223	12	9.3	2500

Customer Service

Anpec Electronics Corp.

Head Office :

5F, No. 2 Li-Hsin Road, SBIP,

Hsin-Chu, Taiwan, R.O.C.

Tel : 886-3-5642000

Fax : 886-3-5642050

Taipei Branch :

7F, No. 137, Lane 235, Pac Chiao Rd.,

Hsin Tien City, Taipei Hsien, Taiwan, R. O. C.

Tel : 886-2-89191368

Fax : 886-2-89191369