

AN7124

Dual 3.1 W Audio Power Amplifier

■ Overview

The AN7124 is a monolithic integrated circuit designed for dual audio power amplifier of portable radio cassette.

■ Features

- Audio output : 3.1 W × 2 channel
- Built-in standby and muting circuit
- Built-in thermal shut down protection circuit
- Low pop noise during standby and mute ON/OFF
- No negative feedback pin

■ Applications

- Radio-cassette

■ Block Diagram

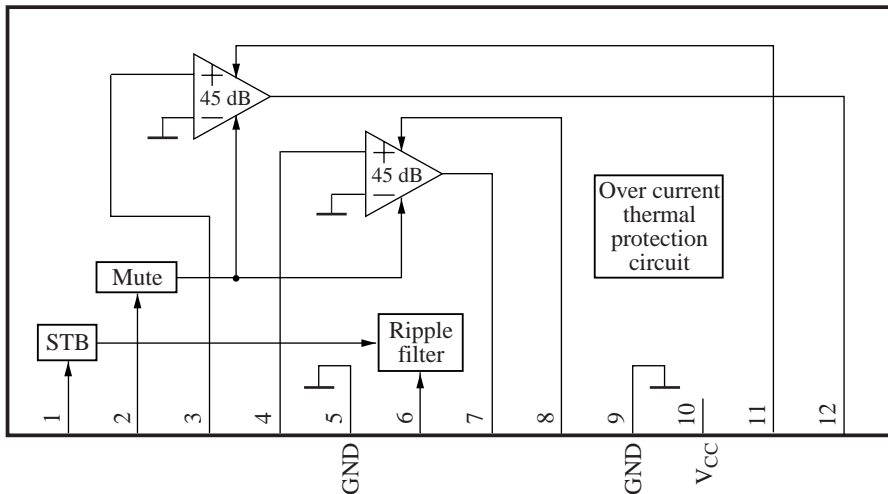

■ Pin Descriptions

Pin No.	Description	Pin No.	Description
1	Stand-by	7	ch.1 output
2	Muting	8	ch.1 bootstrap
3	ch.2 input	9	Output GND
4	ch.1 input	10	V _{CC}
5	Input GND	11	ch.2 bootstrap
6	Ripple filter	12	ch.2 output

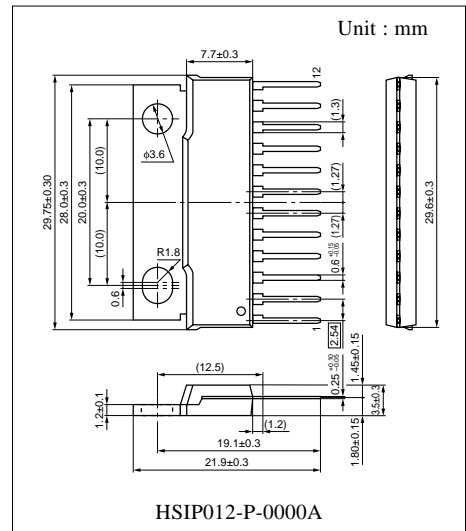

■ Absolute Maximum Ratings

Parameter	Symbol	Rating	Unit
Supply voltage	V_{CC}	24	V
Supply current	I_{CC}	4.0	A
Power dissipation	P_D	37.5	W
Operating ambient temperature	T_{opr}	-25 to +75	°C
Storage temperature	T_{stg}	-55 to +150	°C

■ Recommended Operating Range

Parameter	Symbol	Range	Unit
Supply voltage	V_{CC}	6.0 to 18.0	V

■ Electrical Characteristics at $V_{CC} = 12\text{ V}$, $R_L = 3\ \Omega$, $f = 1\text{ kHz}$, $T_a = 25\text{ °C}$

Parameter	Symbol	Conditions	Min	Typ	Max	Unit
Quiescent current	I_{CQ}	$V_{IN} = 0\text{ mV}$	12	19	26	mA
Output noise voltage *1	V_{NO}	$V_{IN} = 0\text{ mV}, P_G = 10\text{ k}\Omega$	—	0.27	0.5	mVrms
Voltage gain	G_V	$V_{IN} = 3\text{ mV}$	43	45	47	dB
Total harmonic distortion *2	THD	$V_{IN} = 3\text{ mV}$	—	0.05	0.5	%
Maximum output 1	P_{O1}	THD = 10 %	4.3	5.0	—	W
Channel balance	CB	$V_{IN} = 3\text{ mV}$	-1	0	1	dB
Ripple rejection *1	RR	$R_G = 0\ \Omega, V_R = 280\text{ mVrms}, f_R = 120\text{ Hz}$	45	50	—	dB
Standby current	I_{STB}	$V_{IN} = 0\text{ mV}$	—	1	10	μA
Muting effects *1	Mut	$V_{IN} = 10\text{ mV}$	60	80	—	dB
Maximum output 2 *3	P_{O2}	THD = 10 %, $V_{CC} = 9\text{ V}$	2.5	3.0	—	W
Crosstalk *1,*3	CT	$R_G = 10\text{ k}\Omega, V_{IN} = 10\text{ mV}, f = 1\text{ kHz}$	50	64	—	dB

Note) *1 : With a filter band from 20 Hz to 20 kHz (12 dB/OCT) used.

*2 : With a filter band from 400 Hz to 30 kHz used.

*3 : Reference data for design.

■ Application Circuit Example

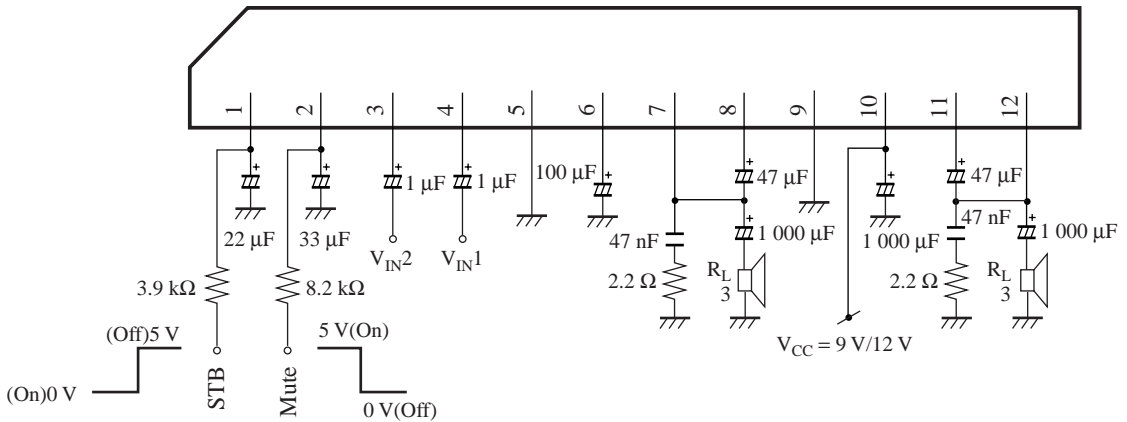

■ Characteristics Curve

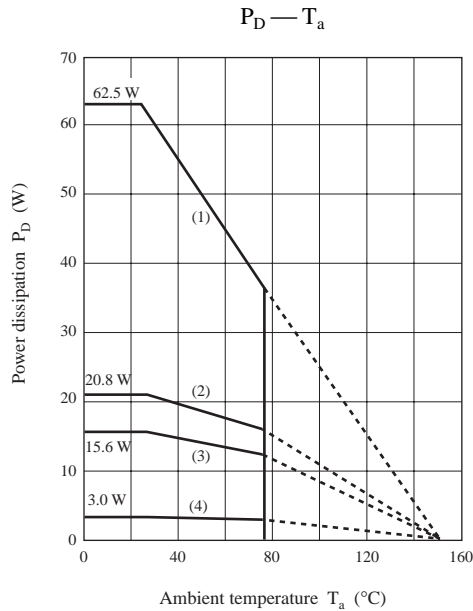

1. $T_C = T_a$ ($\theta_{j-c} = 2 \text{ }^\circ\text{C/W}$)
2. 20.83 W ($\theta_f = 4.0 \text{ }^\circ\text{C/W}$)
With a $100 \text{ cm}^2 \times 3 \text{ mm}$ Al heat sink (black colour coated) or a $200 \text{ cm}^2 \times 2 \text{ mm}$ Al heat sink (not lacquered)
3. 15.63 W ($\theta_f = 6.0 \text{ }^\circ\text{C/W}$)
With a $100 \text{ cm}^2 \times 2 \text{ mm}$ Al heat sink(not lacquered)
4. 3.0 W at $T_a = 25 \text{ }^\circ\text{C}$ ($\theta_{j-a} = 42 \text{ }^\circ\text{C/W}$)
Without heat sink

■ Application Note

1. Voltage gain

The close loop gain of AN7124 is fixed at 45 dB(typ.)

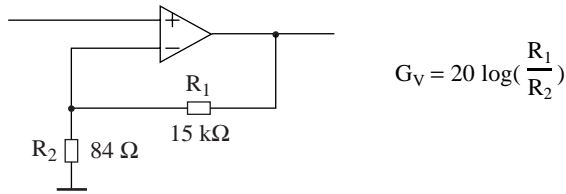

2. Standby function

Standby is ON when Pin1 is set to "L". By applying a 5 V to the standby pin, transistor Q1 will be turned ON to provide a constant current (I) for driving other parts of the circuit. The RC is to create a TIME CONSTANT for the standby pulse during charging and discharging.

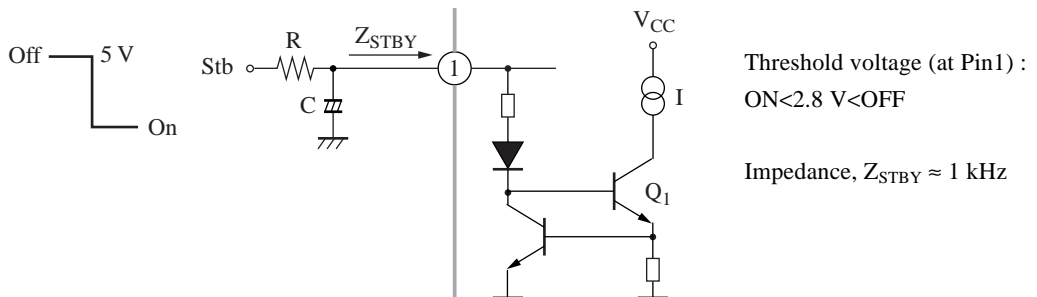

3. Muting

By controlling Pin2 from "H" to "L", the mute function is set from ON to OFF. When Pin2 is floating, DC ≈ 0.02 V. The threshold is set ≈ 2.8 V. The RC is to create a TIME CONSTANT for the mute pulse during charging and discharging.

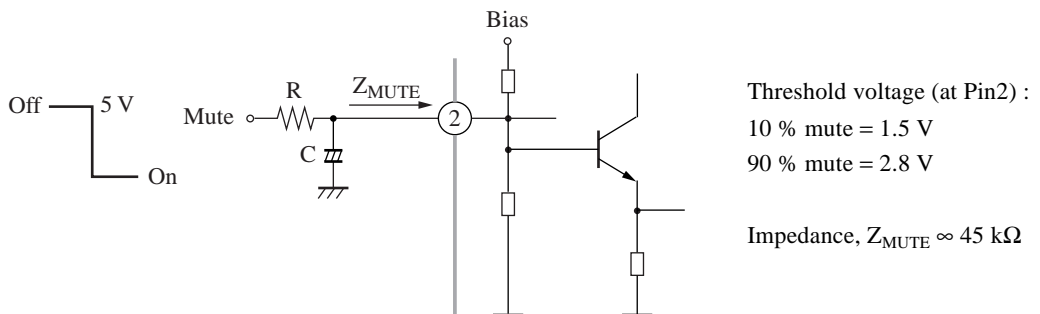

■ Application Note (continued)

4. Oscillation

To prevent oscillation, it is advisable to use C (Zobel network capacitor). Using polyester film capacitor has small characteristic fluctuation with temperature and the frequency. The resistor R connected in series with C is effective for phase correction at high frequency, as a result, it improves the oscillation allowance.

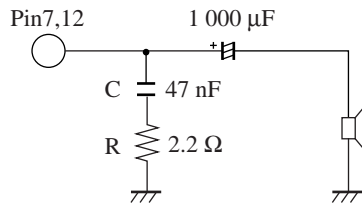

5. Bootstrap

The capacitor C connected between the output and bootstrap pin helps to increase the output dynamic range and hence increases the output power of the IC.

