

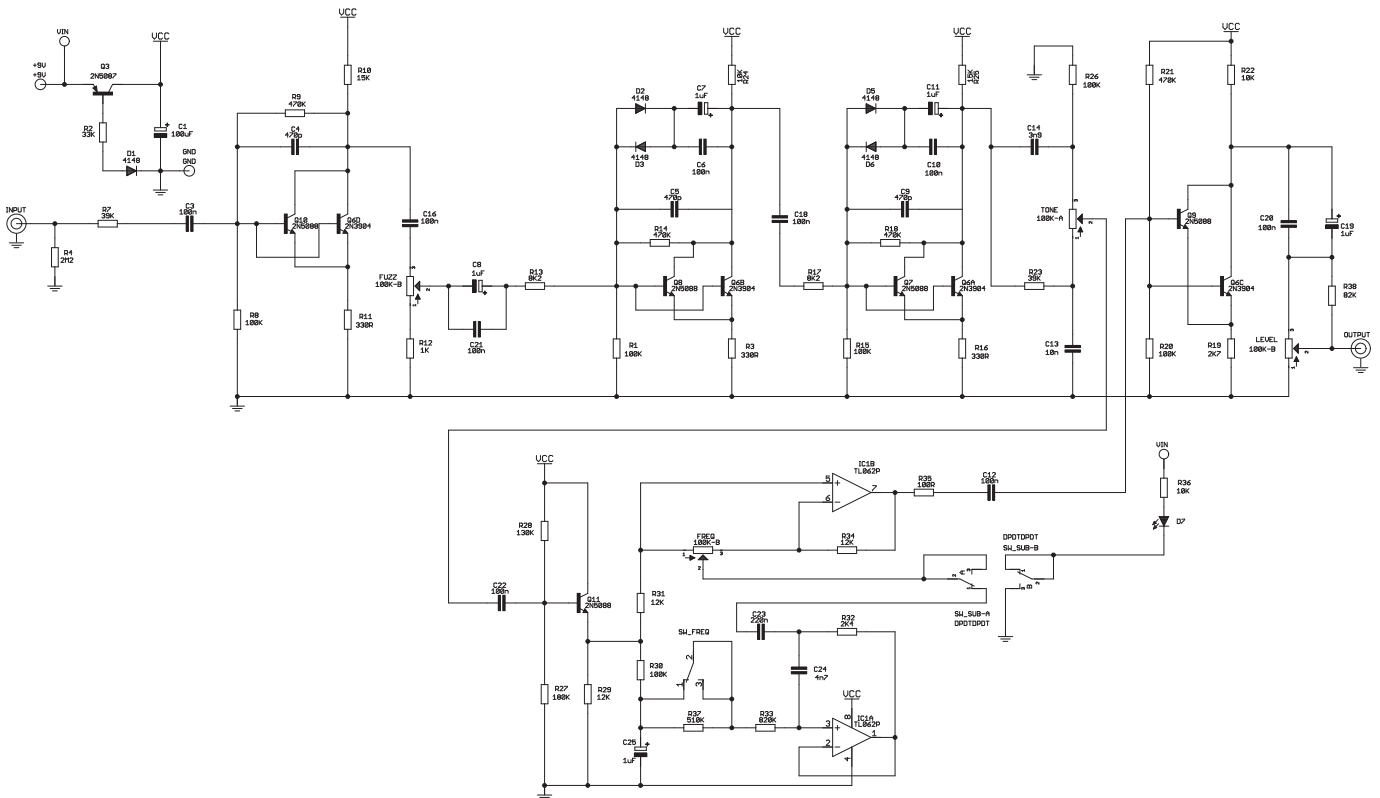

## El Grande Bass Fuzz

Layout por: Güero 2.0

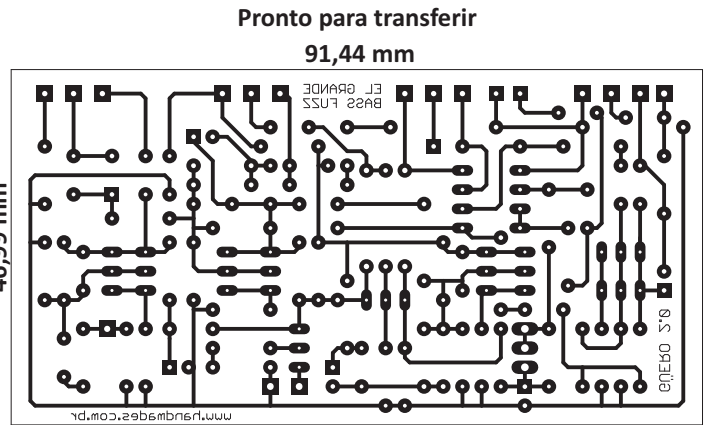

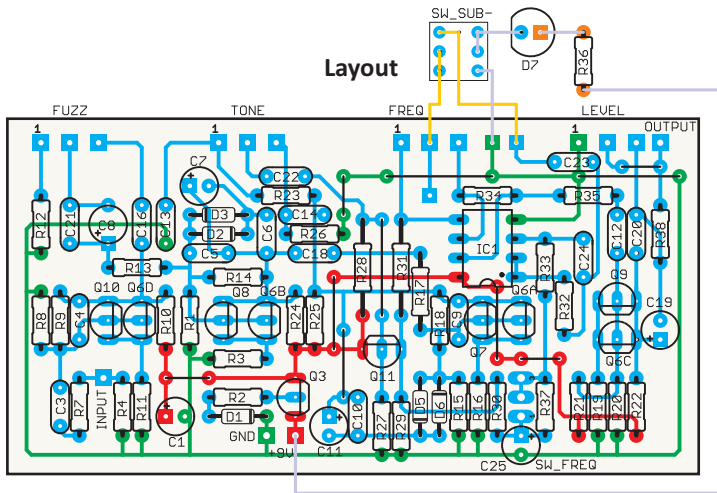

# HANDMADES

WWW.HANDMADES.COM.BR

TECNOLOGIA A FAVOR DA MÚSICA

## El Grande Bass Fuzz

Layout por: Güero 2.0

### Resistores

R1 100K  
R2 33K  
R3 330R  
R4 2M2  
R7 39K  
R8 100K  
R9 470K  
R10 15K  
R11 330R  
R12 1K  
R13 8K2  
R14 470K  
R15 100K  
R16 330R  
R17 8K2  
R18 470K  
R19 2K7  
R20 100K  
R21 470K  
R22 10K  
R23 39K  
R24 10K  
R25 15K  
R26 100K  
R27 180K  
R28 130K  
R29 12K  
R30 100K  
R31 12K  
R32 2K4  
R33 820K  
R34 12K  
R35 100R  
R36 10K  
R37 510K  
R38 82K

### Capacitores

C1 100uF  
C3 100n  
C4 470p  
C5 470p  
C6 100n  
C7 1uF  
C8 1uF  
C9 470p  
C10 100n  
C11 1uF  
C12 100n  
C13 10n  
C14 3n9  
C16 100n  
C18 100n  
C19 1uF  
C20 100n  
C21 100n  
C22 100n  
C23 220n  
C24 4n7  
C25 1uF

### Diodos

D1 4148  
D2 4148  
D3 4148  
D5 4148  
D6 4148  
D7 LED

### Pots

FREQ 100K-B  
FUZZ 100K-B  
LEVEL 100K-B  
TONE 100K-A

### Integrado

IC1 TL062

### Transistores

Q3 2N5087  
Q6A 2N3904  
Q6B 2N3904  
Q6C 2N3904  
Q6D 2N3904  
Q7 2N5088  
Q8 2N5088  
Q9 2N5088  
Q10 2N5088  
Q11 2N5088

### Chaves

SW\_FREQ SPDT  
SW\_SUB DPDT