

SANYO	No. 5066A	LC75854E, 75854W
		1/4 Duty LCD Display Drivers with Key Input Function



Overview

The LC75854E and LC75854W are 1/4 duty LCD display drivers that can directly drive up to 164 segments and can control up to four general-purpose output ports. These products also incorporate a key scan circuit that accepts input from up to 30 keys to reduce printed circuit board wiring.

Features

- Key input function for up to 30 keys (A key scan is performed only when a key is pressed.)
- 1/4 duty - 1/2 bias and 1/4 duty - 1/3 bias drive schemes can be controlled from serial data (up to 164 segments).
- Sleep mode and all segments off functions that are controlled from serial data
- Segment output port/general-purpose output port function switching that is controlled from serial data
- Serial data I/O supports CCB format communication with the system controller.
- Direct display of display data without the use of a decoder provides high generality.
- Provision of an on-chip voltage-detection type reset circuit prevents incorrect displays.
- RC oscillator circuit

- CCB is a trademark of SANYO ELECTRIC CO., LTD.
- CCB is SANYO's original bus format and all the bus addresses are controlled by SANYO.

Package Dimensions

unit: mm

3159-QFP64E

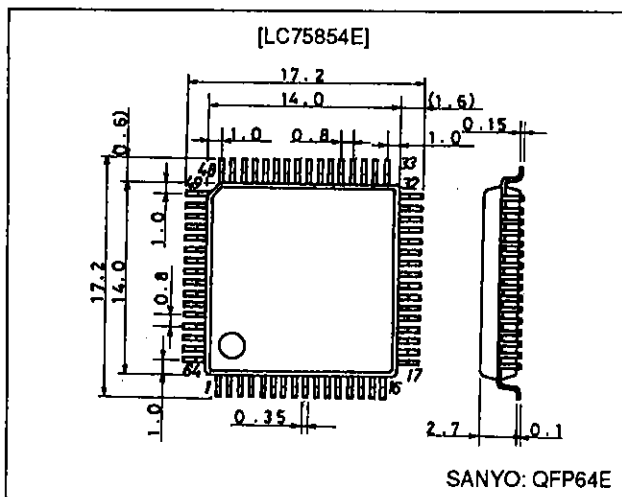

unit: mm

3190-SQFP64

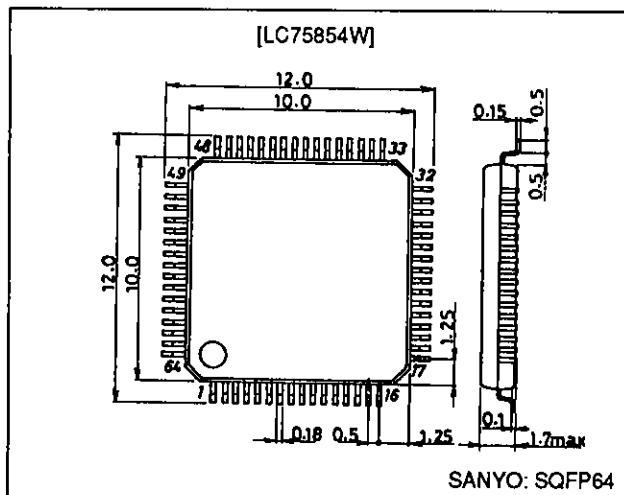

Specifications

Absolute Maximum Ratings at $T_a = 25^\circ\text{C}$, $V_{SS} = 0\text{ V}$

Parameter	Symbol	Conditions	Ratings	Unit
Maximum supply voltage	$V_{DD\text{ max}}$	V_{DD}	-0.3 to +7.0	V
Input voltage	V_{IN1}	CE, CL, DI	-0.3 to +7.0	V
	V_{IN2}	OSC, KI1 to KI5, TEST, V_{DD1} , V_{DD2}	-0.3 to $V_{DD} + 0.3$	V
Output voltage	V_{OUT1}	DO	-0.3 to +7.0	V
	V_{OUT2}	OSC, S1 to S41, COM1 to COM4, KS1 to KS6, P1 to P4	-0.3 to $V_{DD} + 0.3$	V
Output current	I_{OUT1}	S1 to S41	300	μA
	I_{OUT2}	COM1 to COM4	3	mA
	I_{OUT3}	KS1 to KS6	1	mA
	I_{OUT4}	P1 to P4	5	mA
Allowable power dissipation	$P_d\text{ max}$	$T_a = 85^\circ\text{C}$	200	mW
Operating temperature	T_{opr}		-40 to +85	$^\circ\text{C}$
Storage temperature	T_{stg}		-55 to +125	$^\circ\text{C}$

Pin Assignment

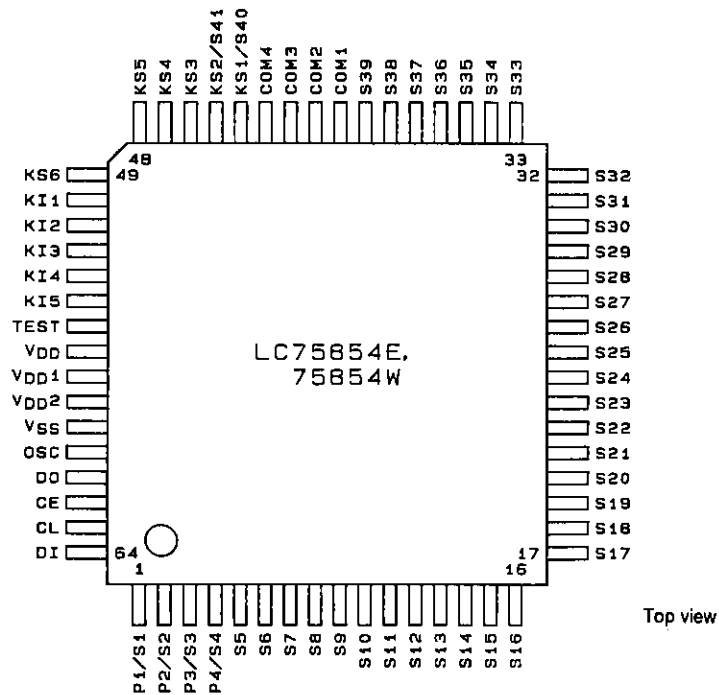

Allowable Operating Ranges at $T_a = -40$ to $+85^\circ\text{C}$, $V_{SS} = 0\text{ V}$

Parameter	Symbol	Conditions	min	typ	max	Unit
Supply voltage	V_{DD}	V_{DD}	4.5		6.0	V
Input voltage	V_{DD1}	V_{DD1}		$2/3 V_{DD}$	V_{DD}	V
	V_{DD2}	V_{DD2}		$1/3 V_{DD}$	V_{DD}	V
Input high level voltage	V_{IH1}	CE, CL, DI	$0.8 V_{DD}$		6.0	V
	V_{IH2}	KI1 to KI5	$0.6 V_{DD}$		V_{DD}	V
Input low level voltage	V_{IL}	CE, CL, DI, KI1 to KI5	0		$0.2 V_{DD}$	V
Recommended external resistance	R_{OSC}	OSC		62		$\text{k}\Omega$
Recommended external capacitance	C_{OSC}	OSC		680		pF
Guaranteed oscillation range	f_{OSC}	OSC	25	50	100	kHz
Data setup time	t_{ds}	CL, DI: Figure 2	160			ns

Continued on next page.

LC75854E, 75854W

Continued from preceding page.

Parameter	Symbol	Conditions	min	typ	max	Unit
Data hold time	t_{dh}	CL, DI: Figure 2	160			ns
CE wait time	t_{cp}	CE, CL: Figure 2	160			ns
CE setup time	t_{cs}	CE, CL: Figure 2	160			ns
CE hold time	t_{ch}	CE, CL: Figure 2	160			ns
High level clock pulse width	t_{cH}	CL: Figure 2	160			ns
Low level clock pulse width	t_{cL}	CL: Figure 2	160			ns
Rise time	t_r	CE, CL, DI: Figure 2		160		ns
Fall time	t_f	CE, CL, DI: Figure 2		160		ns
DO output delay time	t_{dc}	DO, $R_{PU} = 4.7 \text{ k}\Omega$, $C_L = 10 \text{ pF}$ *1: Figure 2			1.5	μs
DO rise time	t_{dr}	DO, $R_{PU} = 4.7 \text{ k}\Omega$, $C_L = 10 \text{ pF}$ *1: Figure 2			1.5	μs

Note: *1. Since DO is an open-drain output, these values depend on the resistance of the pull-up resistor R_{PU} and the load capacitance C_L .

Electrical Characteristics for the Allowable Operating Ranges

Parameter	Symbol	Conditions	min	typ	max	Unit
Hysteresis	V_H	CE, CL, DI		$0.1 V_{DD}$		V
Power-down detection voltage	V_{DET}		2.7	3.0	3.3	V
Input high level current	I_{IH}	CE, CL, DI: $V_I = 6.0 \text{ V}$			5.0	μA
Input low level current	I_{IL}	CE, CL, DI: $V_I = 0 \text{ V}$	-5.0			μA
Input floating voltage	V_{IF}	KI1 to KI5			$0.05 V_{DD}$	V
Pull-down resistance	R_{PD}	KI1 to KI5: $V_{DD} = 5.0 \text{ V}$	50	100	250	$\text{k}\Omega$
Output off leakage current	I_{OFFH}	DO: $V_O = 6.0 \text{ V}$			6.0	μA
Output high level voltage	V_{OH1}	KS1 to KS6: $I_O = -500 \mu\text{A}$	$V_{DD} - 1.2$	$V_{DD} - 0.5$	$V_{DD} - 0.2$	V
	V_{OH2}	P1 to P4: $I_O = -1 \text{ mA}$	$V_{DD} - 1.0$			V
	V_{OH3}	S1 to S41: $I_O = -20 \mu\text{A}$	$V_{DD} - 1.0$			V
	V_{OH4}	COM1 to COM4: $I_O = -100 \mu\text{A}$	$V_{DD} - 1.0$			V
Output low level voltage	V_{OL1}	KS1 to KS6: $I_O = 25 \mu\text{A}$	0.2	0.5	1.5	V
	V_{OL2}	P1 to P4: $I_O = 1 \text{ mA}$			1.0	V
	V_{OL3}	S1 to S41: $I_O = 20 \mu\text{A}$			1.0	V
	V_{OL4}	COM1 to COM4: $I_O = 100 \mu\text{A}$			1.0	V
	V_{OL5}	DO: $I_O = 1 \text{ mA}$		0.1	0.5	V
Output middle level voltage*2	V_{MID1}	COM1 to COM4: 1/2 bias, $I_O = \pm 100 \mu\text{A}$	$1/2 V_{DD} - 1.0$		$1/2 V_{DD} + 1.0$	V
	V_{MID2}	S1 to S41: 1/3 bias, $I_O = \pm 20 \mu\text{A}$	$2/3 V_{DD} - 1.0$		$2/3 V_{DD} + 1.0$	V
	V_{MID3}	S1 to S41: 1/3 bias, $I_O = \pm 20 \mu\text{A}$	$1/3 V_{DD} - 1.0$		$1/3 V_{DD} + 1.0$	V
	V_{MID4}	COM1 to COM4: 1/3 bias, $I_O = \pm 100 \mu\text{A}$	$2/3 V_{DD} - 1.0$		$2/3 V_{DD} + 1.0$	V
	V_{MID5}	COM1 to COM4: 1/3 bias, $I_O = \pm 100 \mu\text{A}$	$1/3 V_{DD} - 1.0$		$1/3 V_{DD} + 1.0$	V
Oscillator frequency	f_{OSC}	OSC: $R = 62 \text{ k}\Omega$, $C = 680 \text{ pF}$	40	50	60	kHz
Current drain	I_{DD1}	Sleep mode			100	μA
	I_{DD2}	$V_{DD} = 6.0 \text{ V}$, output open, 1/2 bias, $f_{OSC} = 50 \text{ kHz}$		250	500	μA
	I_{DD3}	$V_{DD} = 6.0 \text{ V}$, output open, 1/3 bias, $f_{OSC} = 50 \text{ kHz}$		200	400	μA

Note: *2. Excluding the bias voltage generation divider resistor built into V_{DD1} and V_{DD2} . (See Figure 1.)

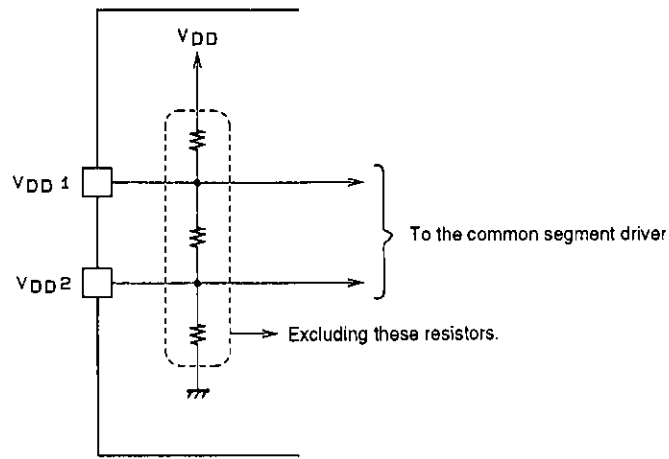
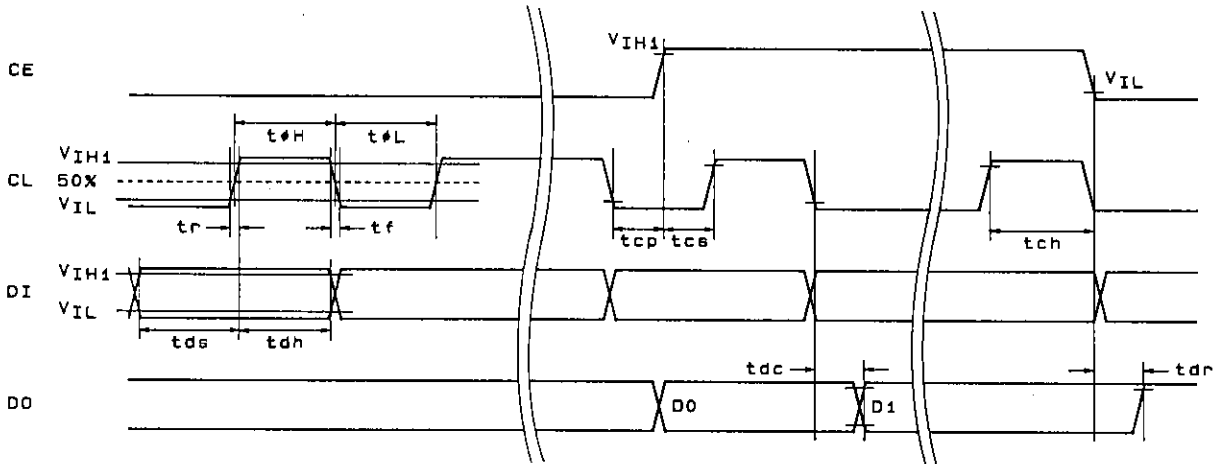

Figure 1

1. When CL is stopped at the low level



2. When CL is stopped at the high level

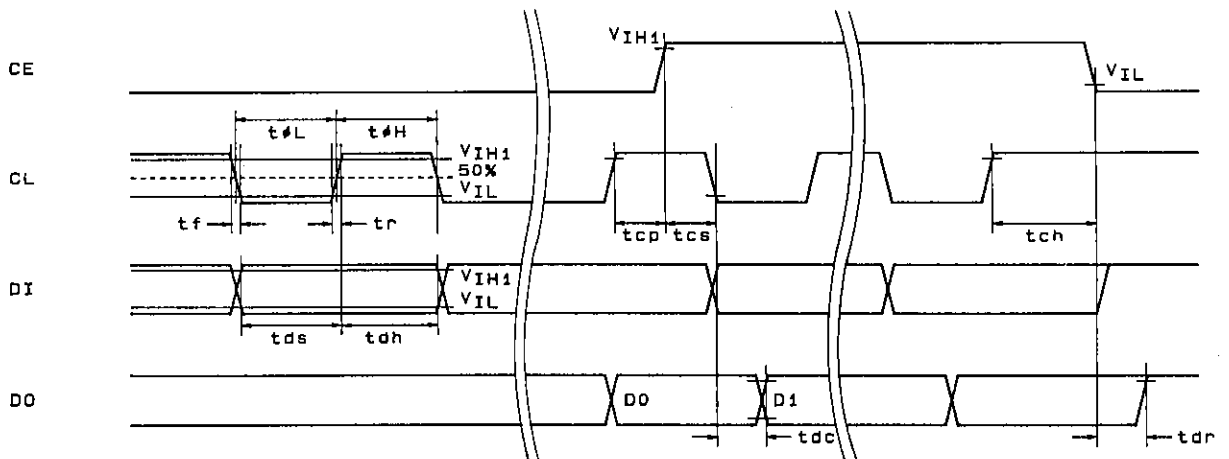
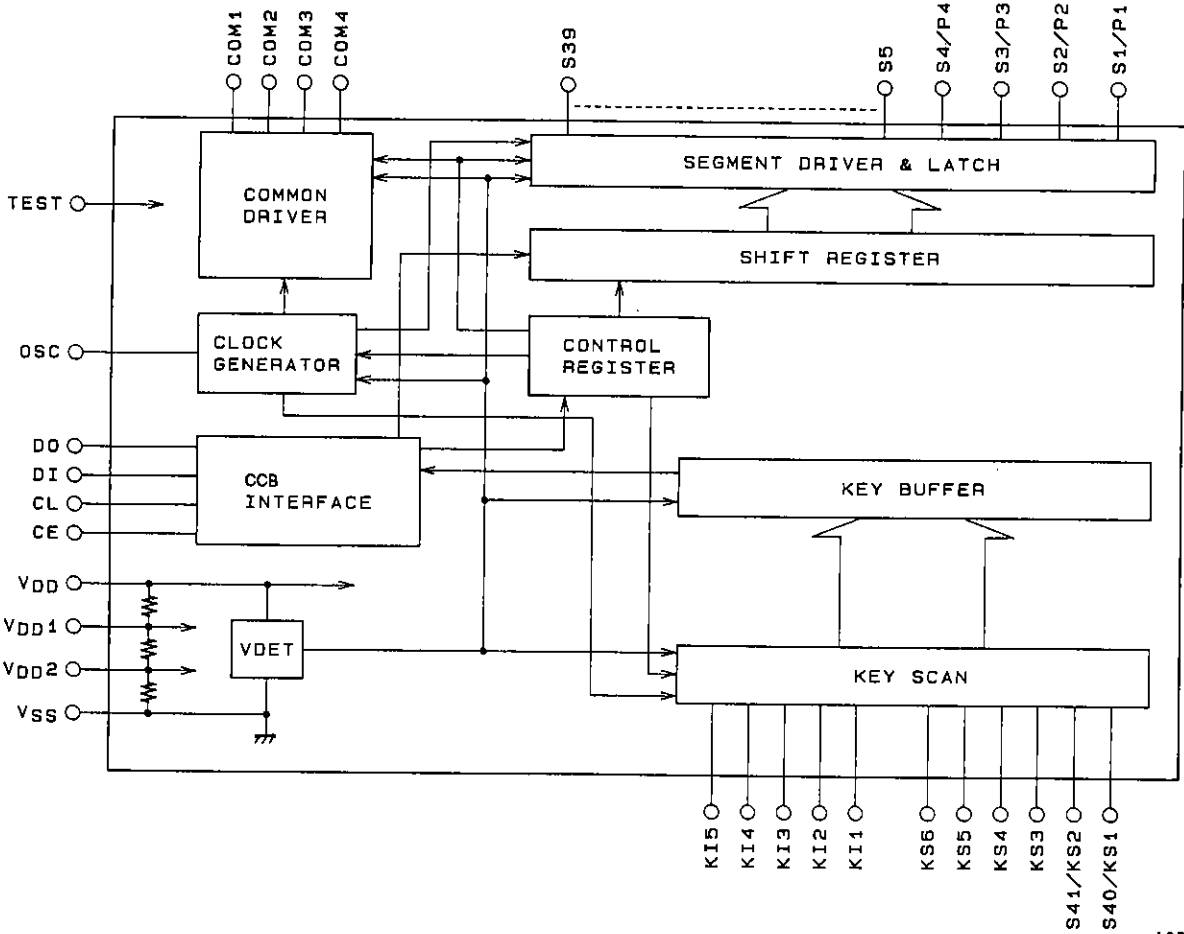



Figure 2

Block Diagram



A03701

Pin Functions

Pin	Pin No.	Function	Active	I/O	Handling when unused
S1/P1 to S4/P4 S5 to S39	1 to 4 5 to 39	Segment outputs for displaying the display data transferred by serial data input. The S1/P1 to S4/P4 pins can be used as general-purpose output ports under serial data control.	—	O	Open
COM1 COM2 COM3 COM4	40 41 42 43	Common driver outputs The frame frequency f_O is given by: $f_O = (f_{OSC}/512)$ Hz.	—	O	Open
KS1/S40, KS2/S41, KS3 to KS6	44 45 46 to 49	Key scan outputs Although normal key scan timing lines require diodes to be inserted in the timing lines to prevent shorts, since these outputs are unbalanced CMOS transistor outputs, these outputs will not be damaged by shorting when these outputs are used to form a key matrix. The KS1/S40 and KS2/S41 pins can be used as segment outputs when so specified by the control data.	—	O	Open
KI1 to KI5	50 to 54	Key scan inputs These pins have built-in pull-down resistors.	H	I	GND
OSC	60	Oscillator connection An oscillator circuit is formed by connecting an external resistor and capacitor at this pin.	—	I/O	V _{DD}
CE CL DI DO	62 63 64 61	Serial data interface connections to the controller. Note that DO, being an open-drain output, requires a pull-up resistor. CE: Chip enable CL: Synchronization clock DI: Transfer data DO: Output data	H  — —	I I I O	GND Open
TEST	55	This pin must be connected to ground.	—	I	—
V _{DD1}	57	Used for applying the LCD drive 2/3 bias voltage externally. Must be connected to V _{DD2} when a 1/2 bias drive scheme is used.	—	I	Open
V _{DD2}	58	Used for applying the LCD drive 1/3 bias voltage externally. Must be connected to V _{DD1} when a 1/2 bias drive scheme is used.	—	I	Open
V _{DD}	56	Power supply connection. Provide a voltage of between 4.5 and 6.0 V.	—	—	—
V _{SS}	59	Power supply connection. Connect to ground.	—	—	—

Serial Data Input

1. When CL is stopped at the low level

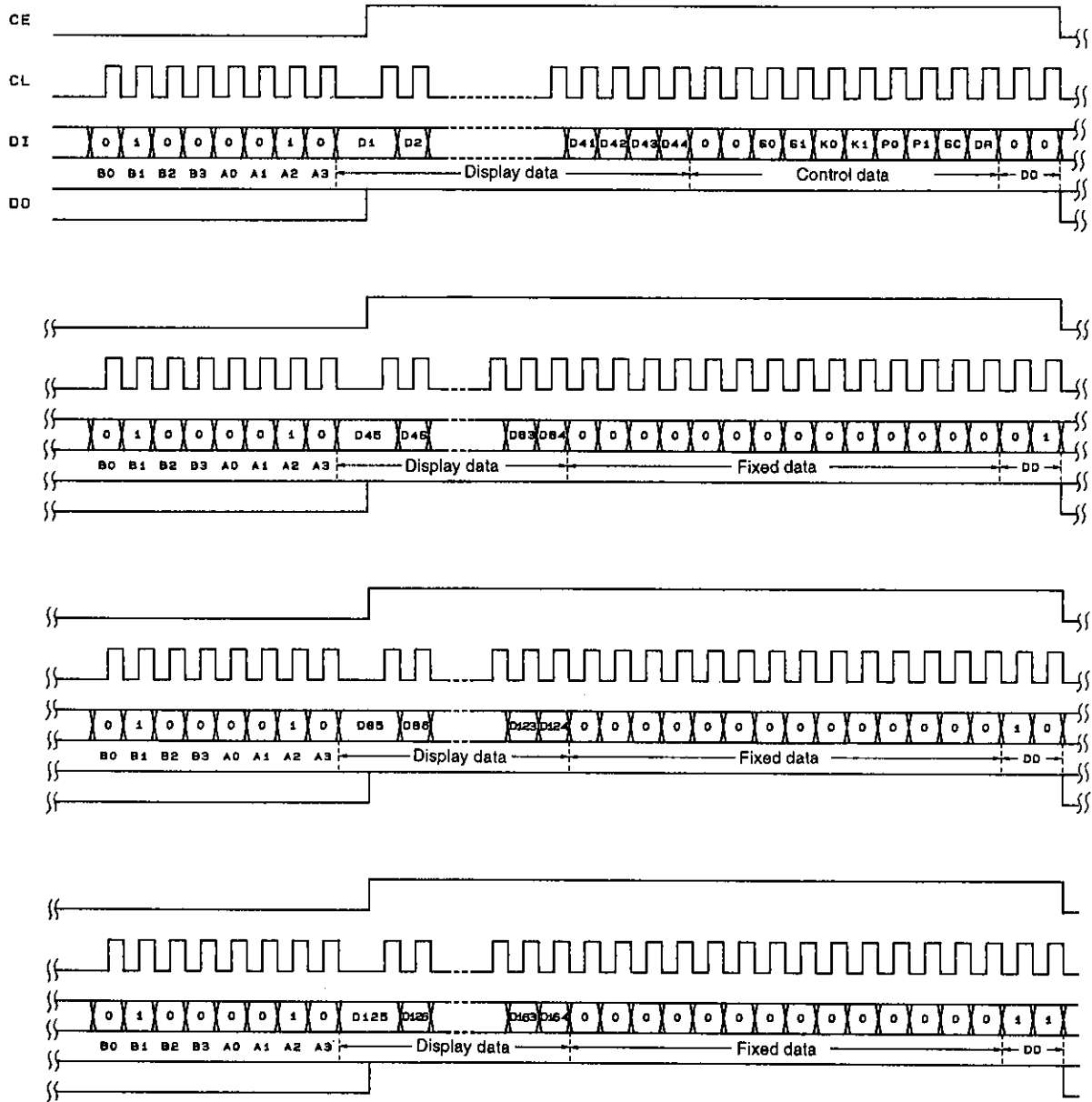

A03702

Note: DD: Direction data

2. When CL is stopped at the high level

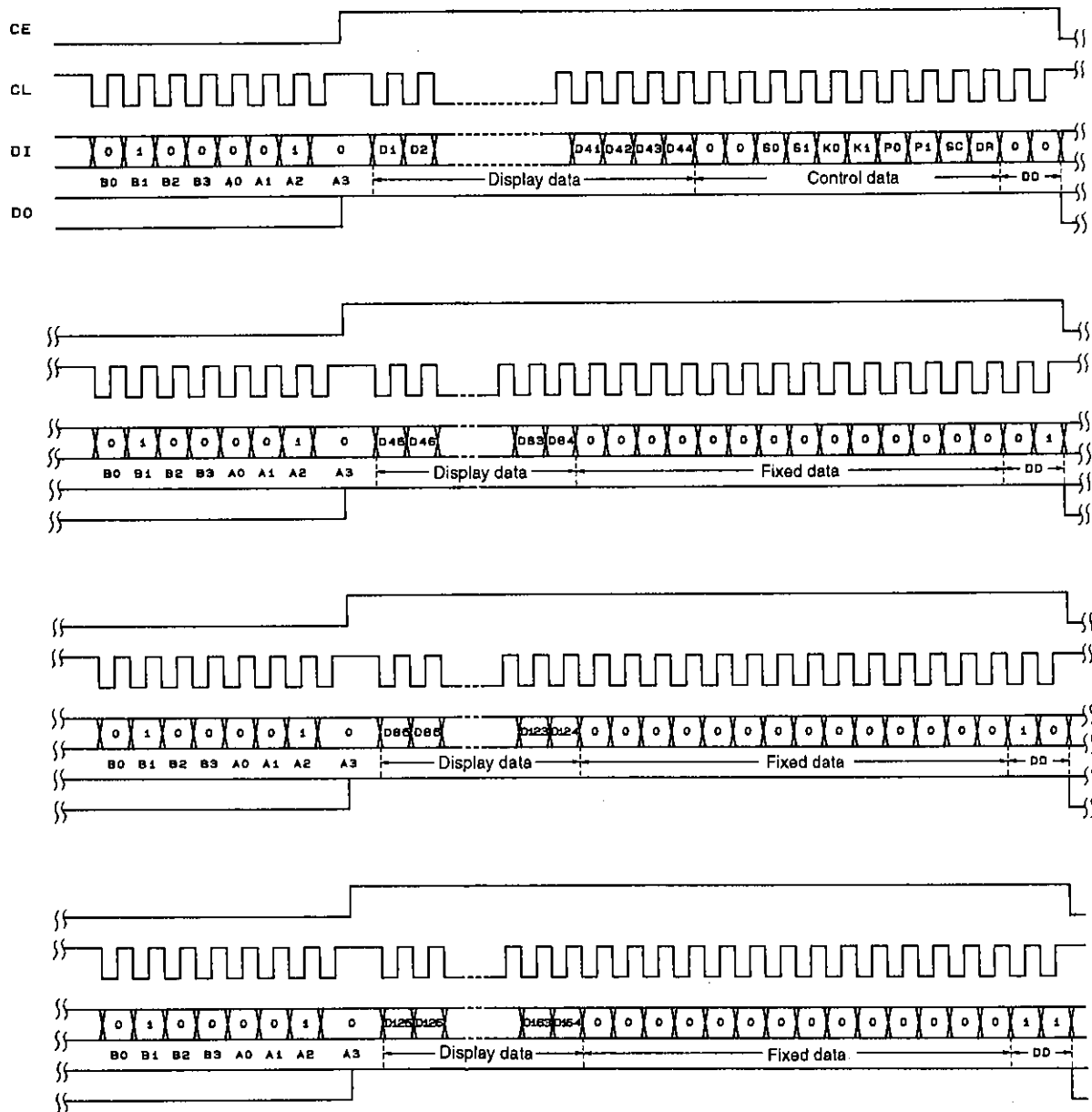

A03703

Note: DD: Direction data

- CCB address.....42H
- D1 to D164.....Display data
- S0, S1Sleep control data
- K0, K1.....Key scan output/segment output selection data
- P0, P1Segment output port/general-purpose output port selection data
- SC.....Segment on/off control data
- DR.....1/2 bias or 1/3 bias drive selection data

Control Data Functions

1. S0, S1: Sleep control data

These control data bits switch between normal mode and sleep mode and set the states of the KS1 to KS6 key scan outputs during key scan standby.

Control data		Mode	OSC oscillator	Segment outputs Common outputs	Output pin states during key scan standby					
S0	S1				KS1	KS2	KS3	KS4	KS5	KS6
0	0	Normal	Operating	Operating	H	H	H	H	H	H
0	1	Sleep	Stopped	L	L	L	L	L	L	H
1	0	Sleep	Stopped	L	L	L	L	H	H	H
1	1	Sleep	Stopped	L	H	H	H	H	H	H

Note: This assumes that the KS1/S40 and KS2/S41 output pins are selected for key scan output.

2. K0, K1: Key scan output/segment output selection data

These control data bits switch the functions of the KS1/S40 and KS2/S41 output pins between key scan output and segment output.

Control data		Output pin state		Maximum number of Input keys
K0	K1	KS1/S40	KS2/S41	
0	0	KS1	KS2	30
0	1	S40	KS2	25
1	X	S40	S41	20

X: don't care

3. P0, P1: Segment output port/general-purpose output port selection data

These control data bits switch the functions of the S1/P1 to S4/P4 output pins between the segment output port and the general-purpose output port.

Control data		Output pin state			
P0	P1	S1/P1	S2/P2	S3/P3	S4/P4
0	0	S1	S2	S3	S4
0	1	P1	P2	S3	S4
1	0	P1	P2	P3	S4
1	1	P1	P2	P3	P4

The table below lists the correspondence between the display data and the output pins when these pins are selected to be general-purpose output ports.

Output pin	Corresponding display data
S1/P1	D1
S2/P2	D5
S3/P3	D9
S4/P4	D13

For example, if the S4/P4 output pin is selected to be a general-purpose output port, the S4/P4 output pin will output a high level when the display data D13 is 1.

4. SC: Segment on/off control data

This control data bit controls the on/off state of the segments.

SC	Display state
0	On
1	Off

However, note that when the segments are turned off by setting SC to 1, the segments are turned off by outputting segment off waveforms from the segment output pins.

5. DR: 1/2 bias or 1/3 bias drive selection data

This control data bit switches between LCD 1/2 bias or 1/3 bias drive.

DR	Drive scheme
0	1/3 bias drive
1	1/2 bias drive

Display Data and Output Pin Correspondence

Output pin	COM1	COM2	COM3	COM4
S1/P1	D1	D2	D3	D4
S2/P2	D5	D6	D7	D8
S3/P3	D9	D10	D11	D12
S4/P4	D13	D14	D15	D16
S5	D17	D18	D19	D20
S6	D21	D22	D23	D24
S7	D25	D26	D27	D28
S8	D29	D30	D31	D32
S9	D33	D34	D35	D36
S10	D37	D38	D39	D40
S11	D41	D42	D43	D44
S12	D45	D46	D47	D48
S13	D49	D50	D51	D52
S14	D53	D54	D55	D56
S15	D57	D58	D59	D60
S16	D61	D62	D63	D64
S17	D65	D66	D67	D68
S18	D69	D70	D71	D72
S19	D73	D74	D75	D76
S20	D77	D78	D79	D80

Output pin	COM1	COM2	COM3	COM4
S21	D81	D82	D83	D84
S22	D85	D86	D87	D88
S23	D89	D90	D91	D92
S24	D93	D94	D95	D96
S25	D97	D98	D99	D100
S26	D101	D102	D103	D104
S27	D105	D106	D107	D108
S28	D109	D110	D111	D112
S29	D113	D114	D115	D116
S30	D117	D118	D119	D120
S31	D121	D122	D123	D124
S32	D125	D126	D127	D128
S33	D129	D130	D131	D132
S34	D133	D134	D135	D136
S35	D137	D138	D139	D140
S36	D141	D142	D143	D144
S37	D145	D146	D147	D148
S38	D149	D150	D151	D152
S39	D153	D154	D155	D156
KS1/S40	D157	D158	D159	D160
KS2/S41	D161	D162	D163	D164

For example, the table below lists the segment output states for the S11 output pin.

Display data				Output pin state
D41	D42	D43	D44	S11
0	0	0	0	The LCD segments for COM1, COM2, COM3 and COM4 are off.
0	0	0	1	The LCD segment for COM4 is on.
0	0	1	0	The LCD segment for COM3 is on.
0	0	1	1	The LCD segments for COM3 and COM4 are on.
0	1	0	0	The LCD segment for COM2 is on.
0	1	0	1	The LCD segments for COM2 and COM4 are on.
0	1	1	0	The LCD segments for COM2 and COM3 are on.
0	1	1	1	The LCD segments for COM2, COM3 and COM4 are on.
1	0	0	0	The LCD segment for COM1 is on.
1	0	0	1	The LCD segments for COM1 and COM4 are on.
1	0	1	0	The LCD segments for COM1 and COM3 are on.
1	0	1	1	The LCD segments for COM1, COM3 and COM4 are on.
1	1	0	0	The LCD segments for COM1 and COM2 are on.
1	1	0	1	The LCD segments for COM1, COM2 and COM4 are on.
1	1	1	0	The LCD segments for COM1, COM2 and COM3 are on.
1	1	1	1	The LCD segments for COM1, COM2, COM3 and COM4 are on.

Serial Data Output

1. When CL is stopped at the low level

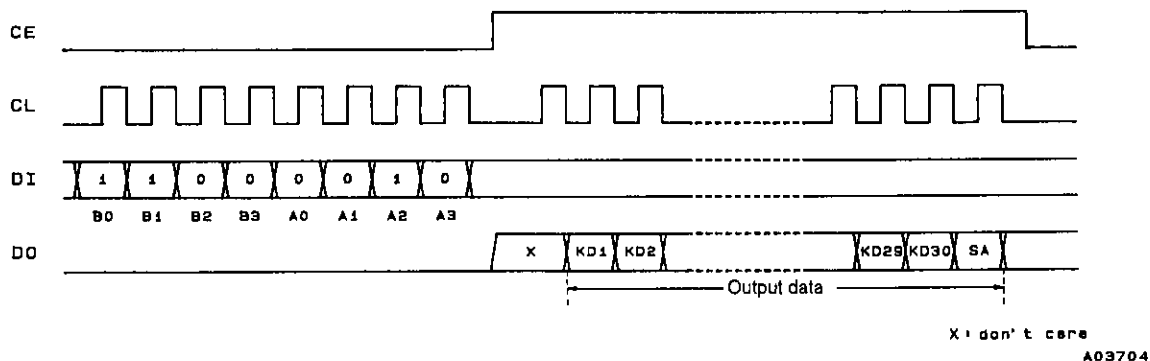

2. When CL is stopped at the high level

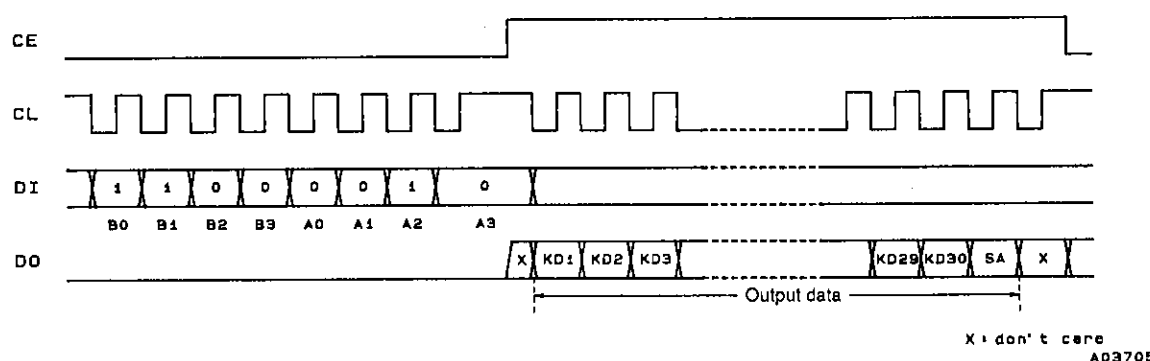

- CCB address.....43H
- KD1 to KD30.....Key data
- SA.....Sleep acknowledge data

Note: If a key data read operation is executed when DO is high, the read key data (KD1 to KD30) and sleep acknowledge data (SA) will be invalid.

Output Data

1. KD1 to KD30: Key data

When a key matrix of up to 30 keys is formed from the KS1 to KS6 output pins and the KI1 to KI5 input pins and one of those keys is pressed, the key output data corresponding to that key will be set to 1. The table shows the relationship between those pins and the key data bits.

	KI1	KI2	KI3	KI4	KI5
KS1/S40	KD1	KD2	KD3	KD4	KD5
KS2/S41	KD6	KD7	KD8	KD9	KD10
KS3	KD11	KD12	KD13	KD14	KD15
KS4	KD16	KD17	KD18	KD19	KD20
KS5	KD21	KD22	KD23	KD24	KD25
KS6	KD26	KD27	KD28	KD29	KD30

When the KS1/S40 and KS2/S41 output pins are selected to be segment outputs by control data bits K0 and K1 and a key matrix of up to 20 keys is formed using the KS3 to KS6 output pins and the KI1 to KI5 input pins, the KD1 to KD10 key data bits will be set to 0.

2. SA: Sleep acknowledge data

This output data bit is set to the state when the key was pressed. Also, while DO will be low in this case, if serial data is input and the mode is set (to normal or sleep mode) during this period, that mode will be set. SA will be 1 in sleep mode and 0 in normal mode.

Sleep Mode Functions

Sleep mode is set up by setting S0 or S1 in the control data to 1. The segment outputs will all go low and the common outputs will also go low, and the oscillator on the OSC pin will stop (it will be started by a key press). This reduces power dissipation. This mode is cleared by sending control data with both S0 and S1 set to 0. However, note that the S1/P1 to S4/P4 outputs can be used as general-purpose output ports according to the state of the P0 and P1 control data bits, even in sleep mode. (See the control data description for details.)

Key Scan Operation Functions

1. Key scan timing

The key scan period is 384 T (s). To reliably determine the on/off state of the keys, the LC75854E/W scans the keys twice and determines that a key has been pressed when the key data agrees. It outputs a key data read request (a low level on DO) 800 T (s) after starting a key scan. If the key data does not agree and a key was pressed at that point, it scans the keys again. Thus the LC75854E/W cannot detect a key press shorter than 800 T (s).

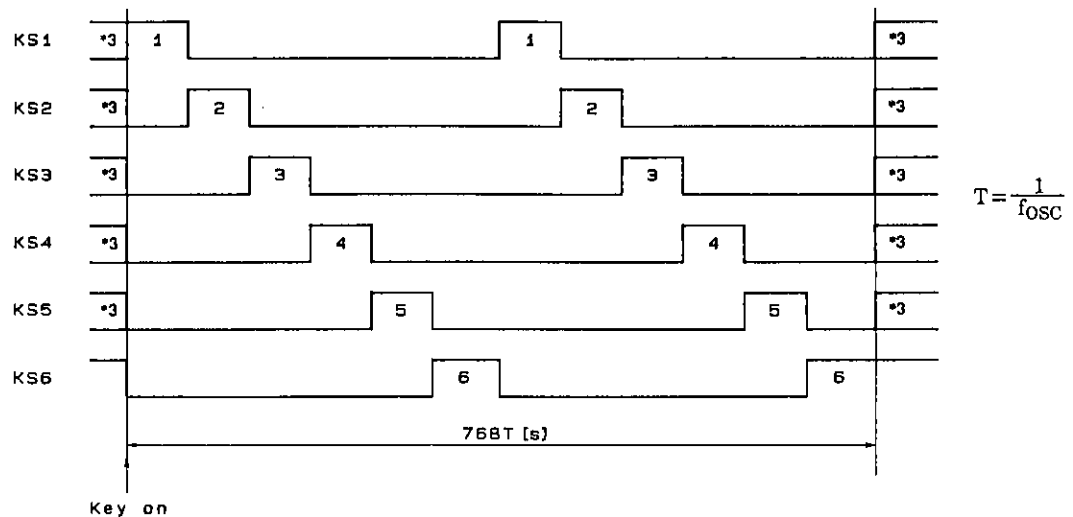

A03706

Note: *3. In sleep mode the high/low state of these pins is determined by the S0 and S1 bits in the control data. Key scan output signals are not output from pins that are set low.

2. In normal mode

- The pins KS1 to KS6 are set high
- When a key is pressed a key scan is started and the keys are scanned until all keys are released. Multiple key presses are recognized by determining whether multiple key data bits are set.
- If a key is pressed for longer than 800 T (s) (where $T = \frac{1}{f_{OSC}}$) the LC75854E/W outputs a key data read request (a low level on DO) to the controller. The controller acknowledges this request and reads the key data. However, if CE is high during a serial data transfer, DO will be set high.
- After the controller reads the key data, the key data read request is cleared (DO is set high) and the LC75854E/W performs another key scan. Also note that DO, being an open-drain output, requires a pull-up resistor (between 1 and 10 kΩ).

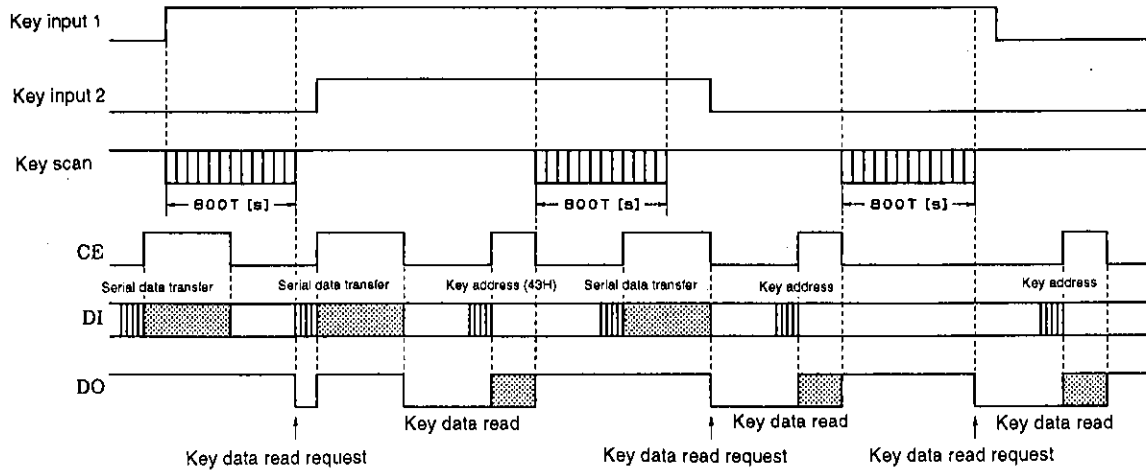

$$T = \frac{1}{f_{OSC}}$$

A03707

3. In sleep mode

- The pins KS1 to KS6 are set to high or low by the S0 and S1 bits in the control data. (See the control data description for details.)
- If a key on one of the lines corresponding to a KS1 to KS6 pin which is set high is pressed, the oscillator on the OSC pin is started and a key scan is performed. Keys are scanned until all keys are released. Multiple key presses are recognized by determining whether multiple key data bits are set.
- If a key is pressed for longer than $800 T$ (s) (where $T = \frac{1}{f_{OSC}}$) the LC75854E/W outputs a key data read request (a low level on DO) to the controller. The controller acknowledges this request and reads the key data. However, if CE is high during a serial data transfer, DO will be set high.
- After the controller reads the key data, the key data read request is cleared (DO is set high) and the LC75854E/W performs another key scan. However, this does not clear sleep mode. Also note that DO, being an open-drain output, requires a pull-up resistor (between 1 and 10 kΩ).
- Sleep mode key scan example
Example: S0 = 0, S1 = 1 (sleep with only KS6 high)

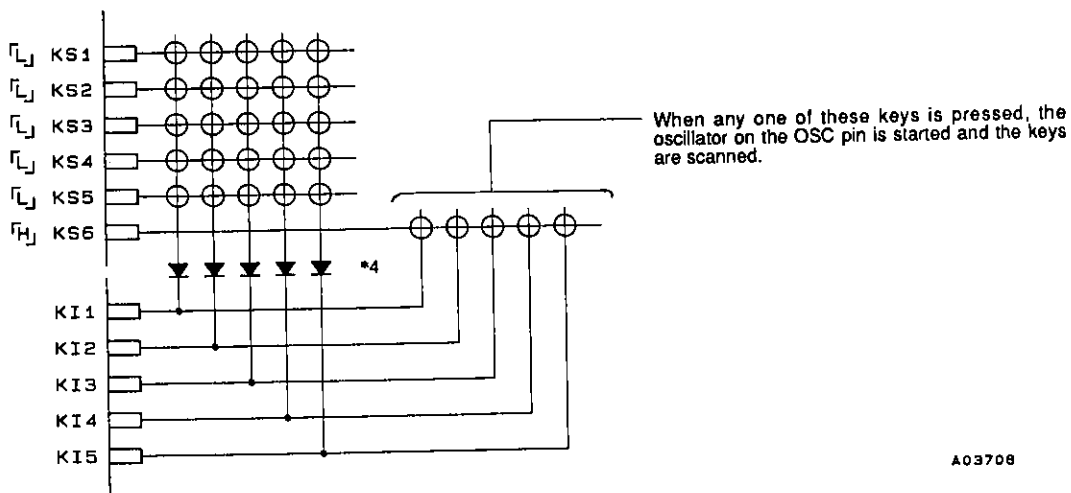

A03708

Note *4. These diodes are required to reliably recognize multiple key presses on the KS6 line when sleep mode state with only KS6 high, as in the above example. That is, these diodes prevent incorrect operations due to sneak currents in the KS6 key scan output signal when keys on the KS1 to KS5 lines are pressed at the same time.

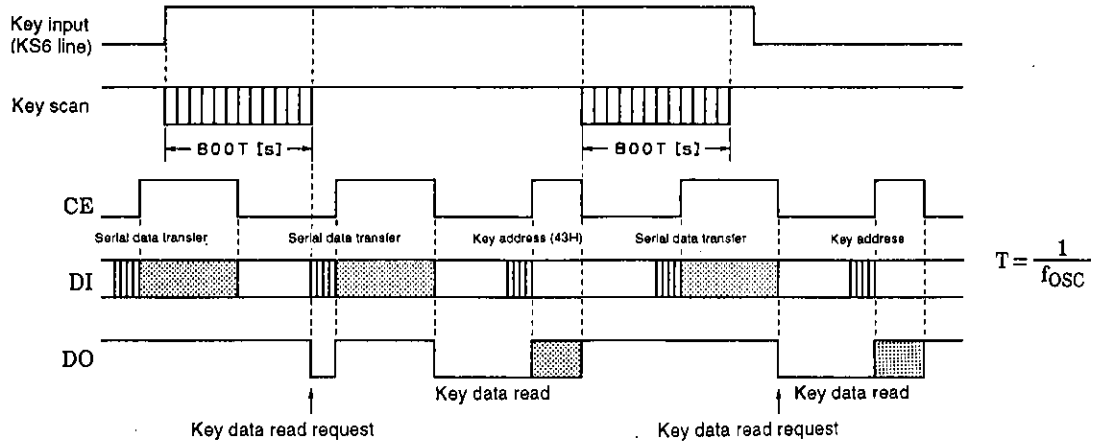

A03708

Multiple Key Presses

Although the LC75854E/W is capable of key scanning without inserting diodes for dual key presses, triple key presses on the KI1 to KI5 input pin lines, or multiple key presses on the KS1 to KS6 output pin lines, multiple presses other than these cases may result in keys that were not pressed recognized as having been pressed. Therefore, a diode must be inserted in series with each key. Applications that do not recognize multiple key presses of three or more keys should check the key data for three or more 1 bits and ignore such data.

1/4 Duty, 1/2 Bias Drive Technique

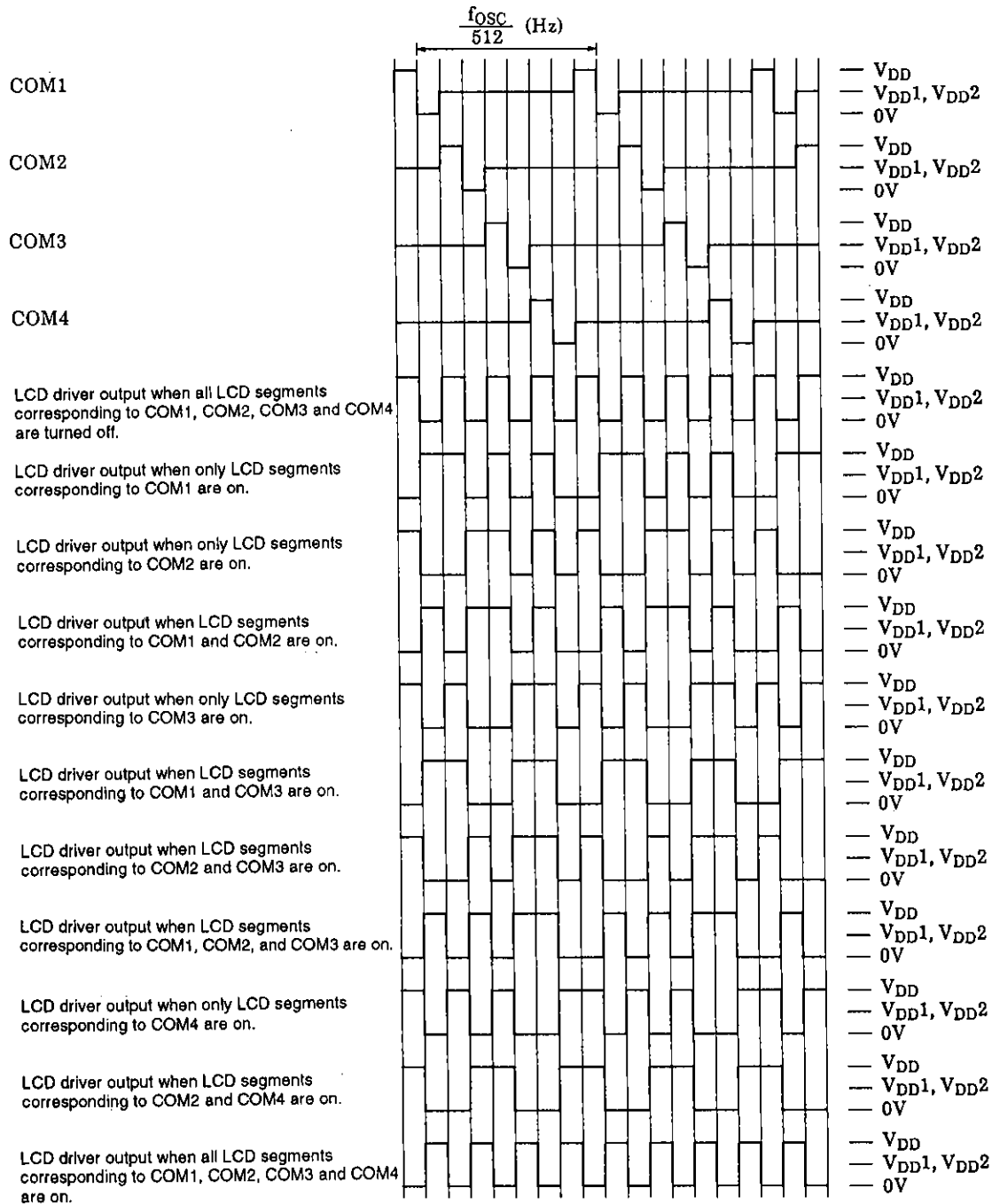

1/4 Duty, 1/2 Bias Waveforms

A03710

1/4 Duty, 1/3 Bias Drive Technique

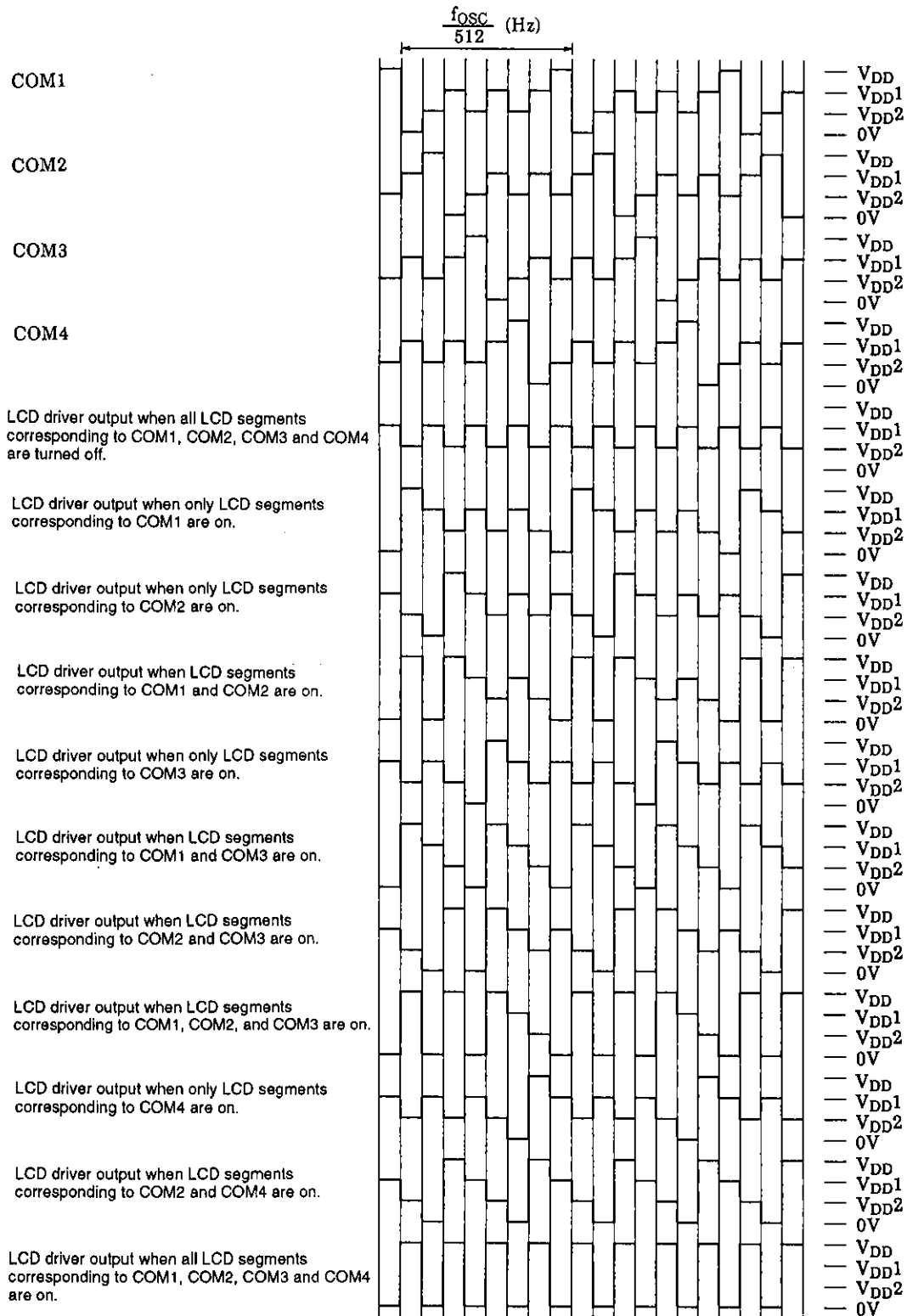

1/4 Duty, 1/3 Bias Waveforms

A03711

Voltage Detection Type Reset Circuit (VDET)

This circuit generates an output signal and resets the system when power is first applied and when the voltage drops, i.e., when the power supply voltage is less than or equal to the power down detection voltage VDET, which is 3.0 V, typical. To assure that this function operates reliably, a capacitor must be added to the power supply line so that the power supply voltage V_{DD} rise time when power is first applied and the power supply voltage V_{DD} fall time when the voltage drops are both at least 1 ms. (See Figure 3.)

System Reset

1. Reset method

If at least 1 ms is assured as the supply voltage V_{DD} rise time when power is applied, a system reset will be applied by the VDET output signal when the supply voltage is brought up. If at least 1 ms is assured as the supply voltage V_{DD} fall time when power drops, a system reset will be applied in the same manner by the VDET output signal when the supply voltage is lowered. Note that the reset is cleared at the point when all the serial data (the display data D1 to D164 and the control data) has been transferred, i.e., on the fall of the CE signal on the transfer of the last direction data, after all the direction data has been transferred. (See Figure 3.)

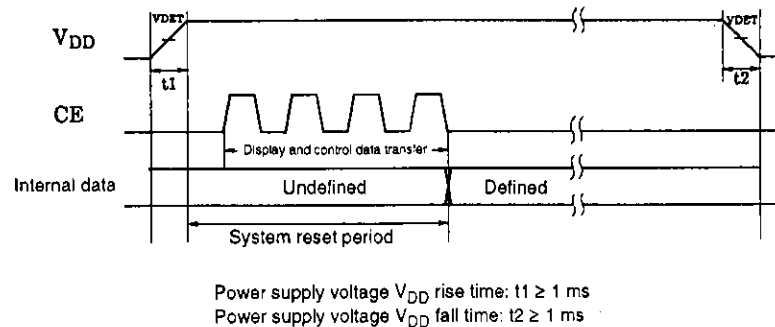

A09712

Figure 3

2. LC75854E/W internal block states during the reset period

- **CLOCK GENERATOR**
Reset is applied and the base clock is stopped. However the OSC pin state (normal or sleep mode) is determined after the S0 and S1 control data bits are transferred.
- **COMMON DRIVER, SEGMENT DRIVER & LATCH**
Reset is applied and the display is turned off. However, display data can be input to the latch circuit in this state.
- **KEY SCAN**
Reset is applied, the circuit is set to the initial state, and at the same time the key scan operation is disabled.
- **KEY BUFFER**
Reset is applied and all the key data is set to low.
- **CCB INTERFACE, CONTROL REGISTER, SHIFT REGISTER**
Since serial data transfer is possible, these circuits are not reset.

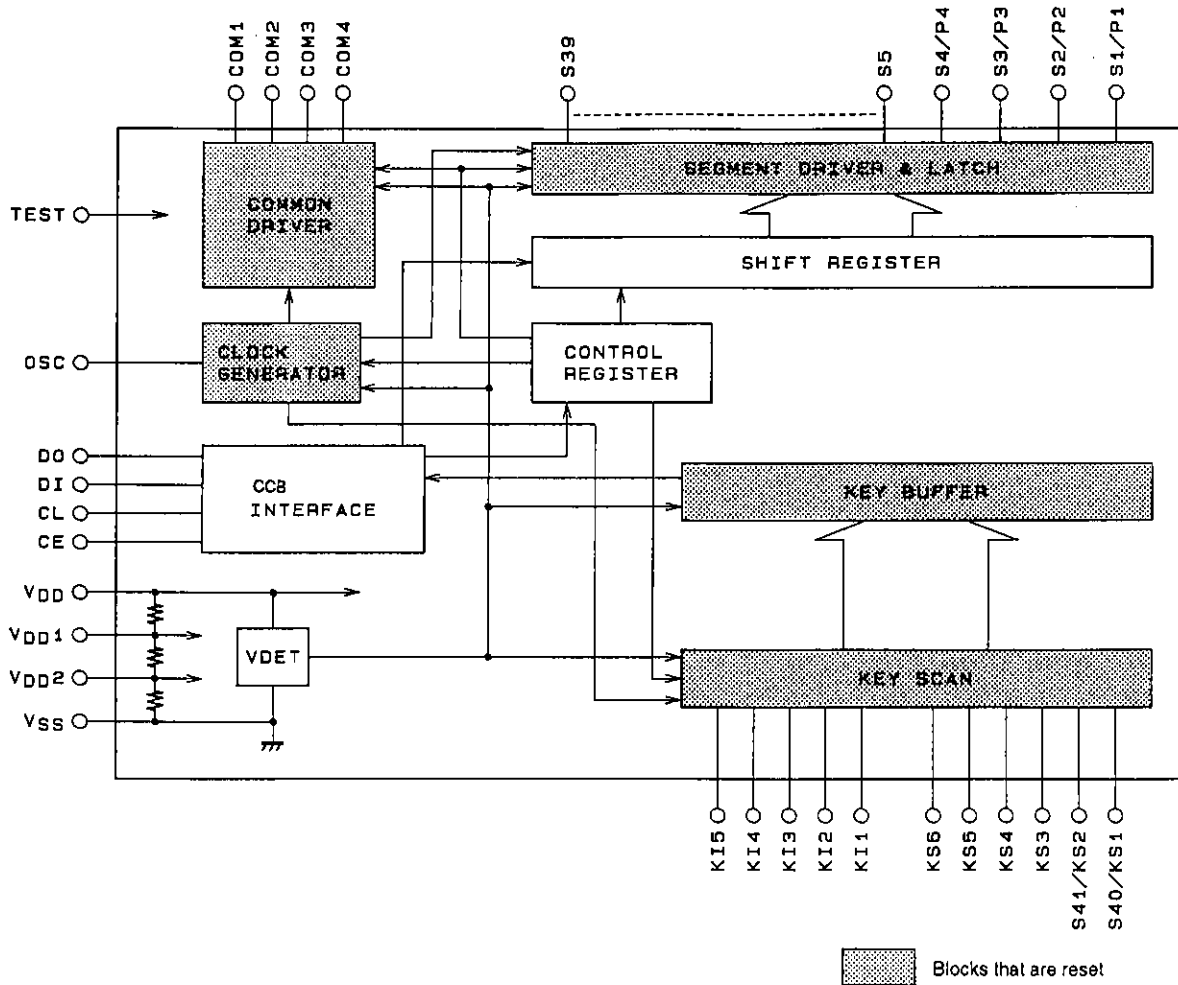

A03713

3. Output pin states during the reset period

Output pin	State during reset
S1/P1 to S4/P4	L*5
S5 to S39	L
COM1 to COM4	L
KS1/S40, KS2/S41	L*5
KS3 to KS5	X*6
KS6	H
DO	H*7

X: Don't care

Note: * 5. These output pins are forcibly set to the segment output function and held low.

* 6. When power is first applied, these output pins are undefined until the S0 and S1 control data bits have been transferred.

* 7. Since this output pin is an open-drain output, a pull-up resistor of between 1 and 10 kΩ is required. This pin remains high during the reset period even if a key data read operation is performed.

Sample Application Circuit 1

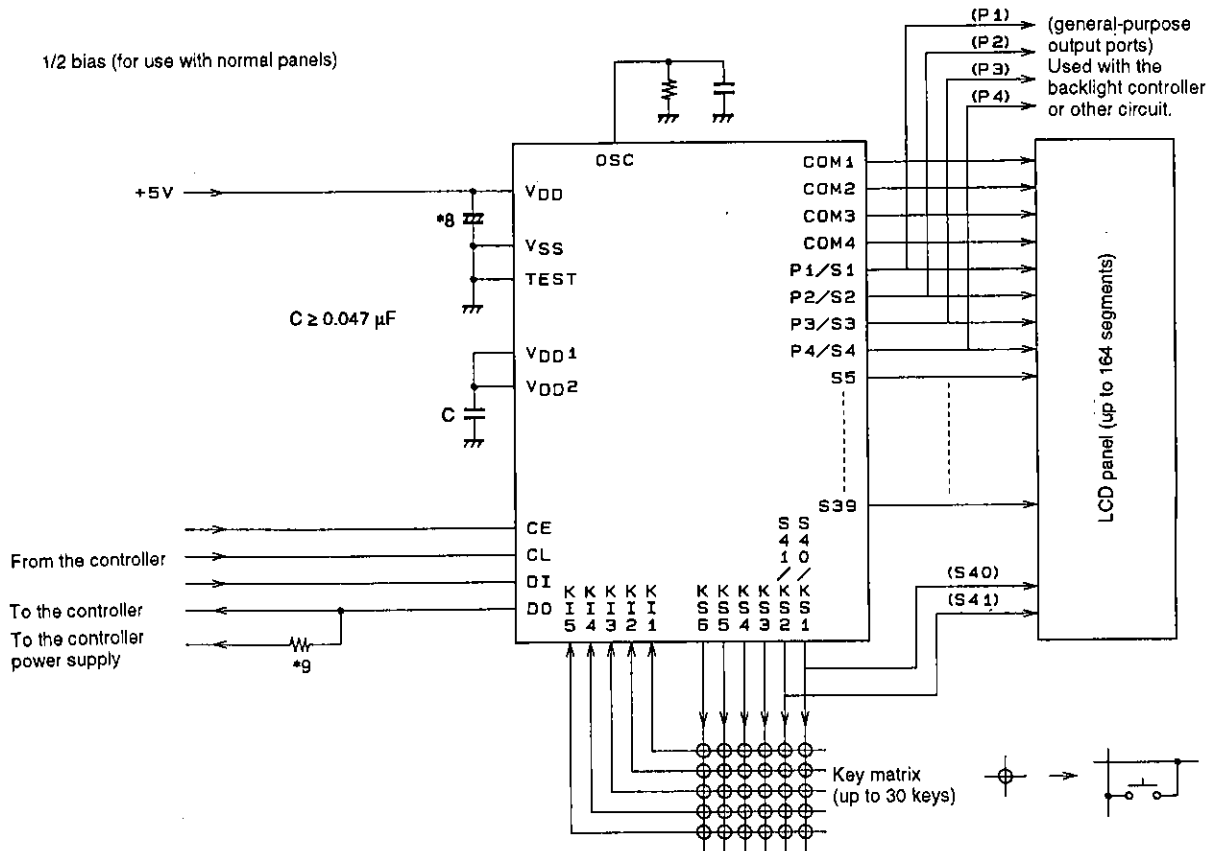

A03714

- Note: *8. Add a capacitor to the power supply line so that the power supply voltage V_{DD} rise time when power is applied and the power supply voltage V_{DD} fall time when power drops are both at least 1 ms, as the LC75854E/W is reset by the VDET.
- *9. The DO pin, being an open-drain output, requires a pull-up resistor. Select a resistance (between 1 to 10 kΩ) appropriate for the capacitance of the external wiring so that signal waveforms are not degraded.

Sample Application Circuit 2

1/3 bias (for use with normal panels)

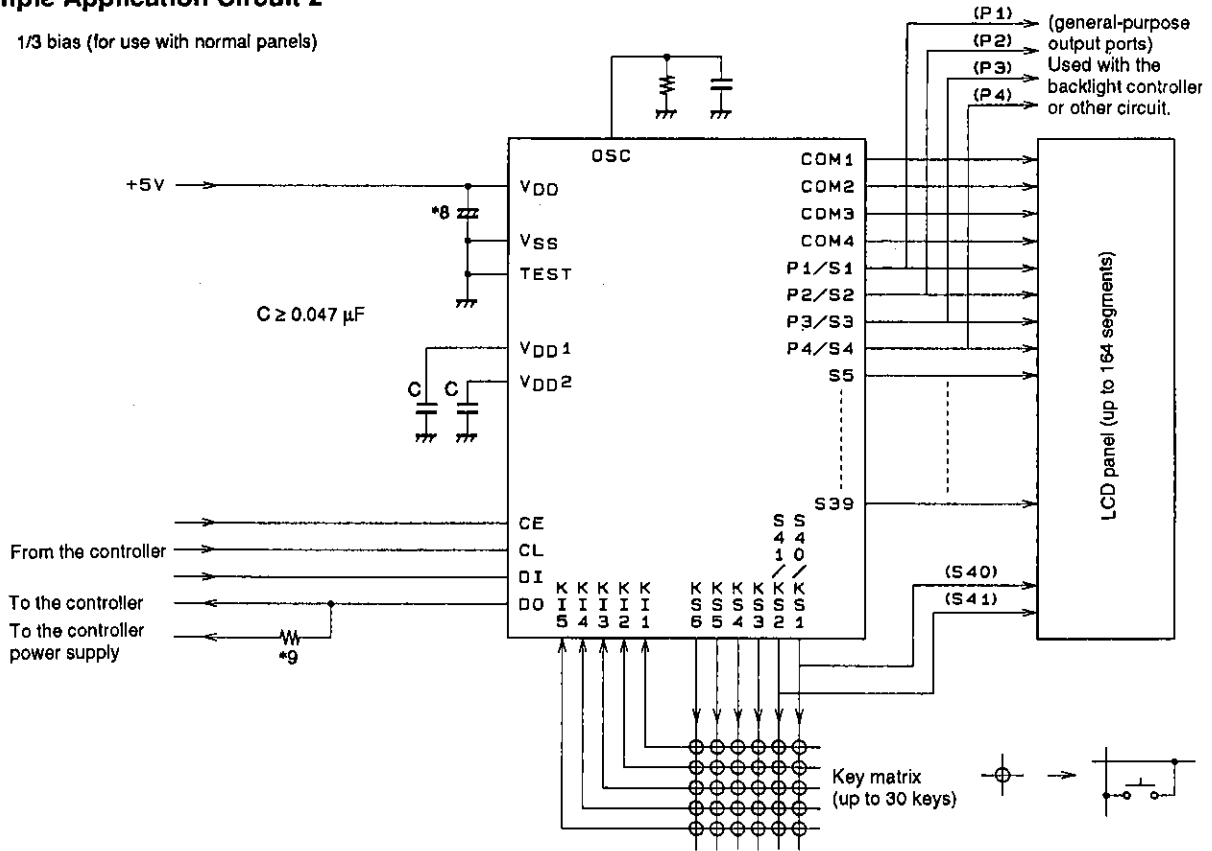

A03718

- Note: *8. Add a capacitor to the power supply line so that the power supply voltage V_{DD} rise time when power is applied and the power supply voltage V_{DD} fall time when power drops are both at least 1 ms, as the LC75854E/W is reset by the VDET.
- *9. The DO pin, being an open-drain output, requires a pull-up resistor. Select a resistance (between 1 to 10 k Ω) appropriate for the capacitance of the external wiring so that signal waveforms are not degraded.

Sample Application Circuit 3

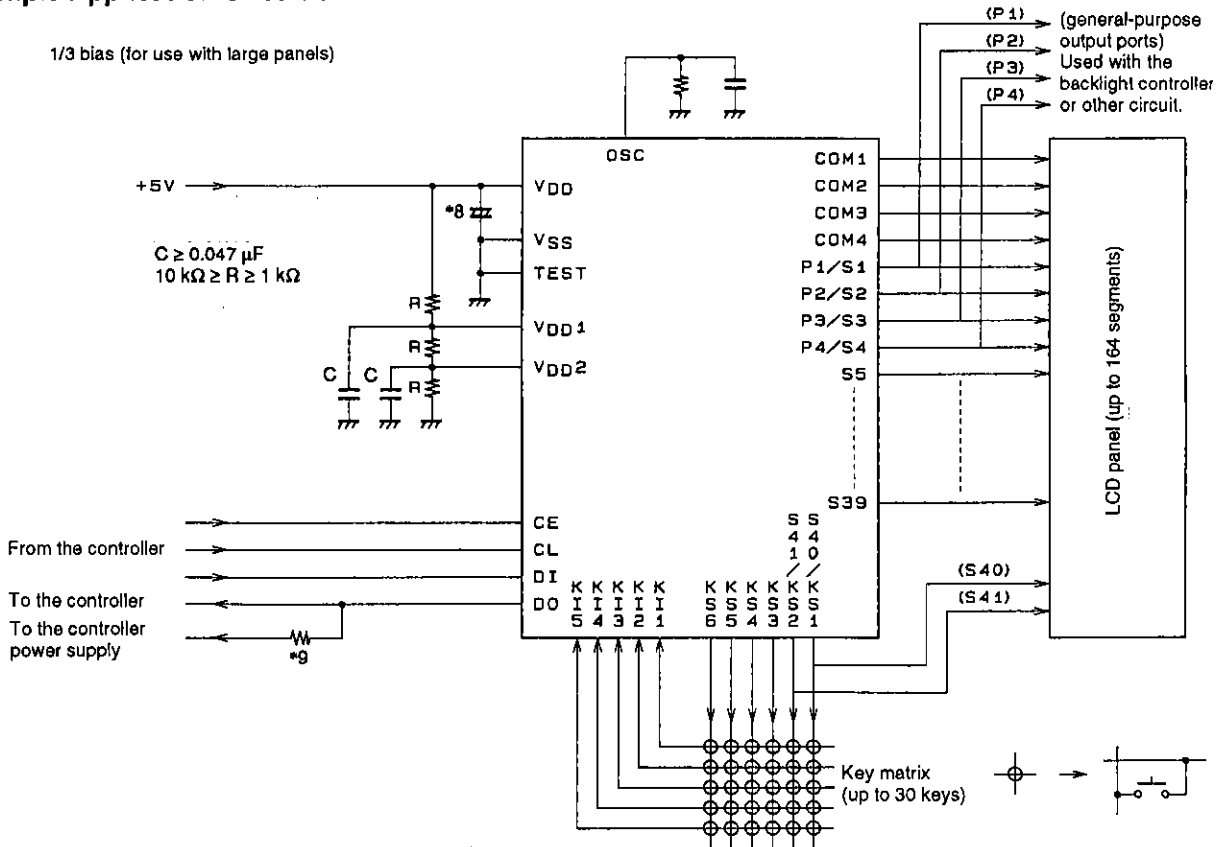

A03715

- Note: *8. Add a capacitor to the power supply line so that the power supply voltage V_{DD} rise time when power is applied and the power supply voltage V_{DD} fall time when power drops are both at least 1 ms, as the LC75854E/W is reset by the VDET.
- *9. The DO pin, being an open-drain output, requires a pull-up resistor. Select a resistance (between 1 to 10 k Ω) appropriate for the capacitance of the external wiring so that signal waveforms are not degraded.

Notes on transferring display data from the controller

The display data (D1 to D164) is transferred to the LC75854E/W in four operations. All of the display data should be transferred within 30 ms to maintain the quality of the displayed image.

Notes on the controller key data read techniques

1. Timer based key data acquisition
 - Flowchart

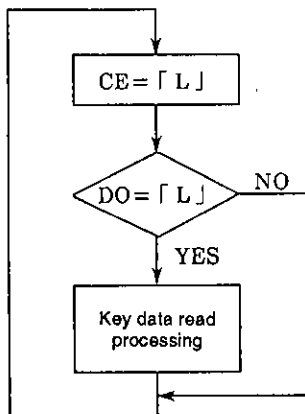

• Timing chart

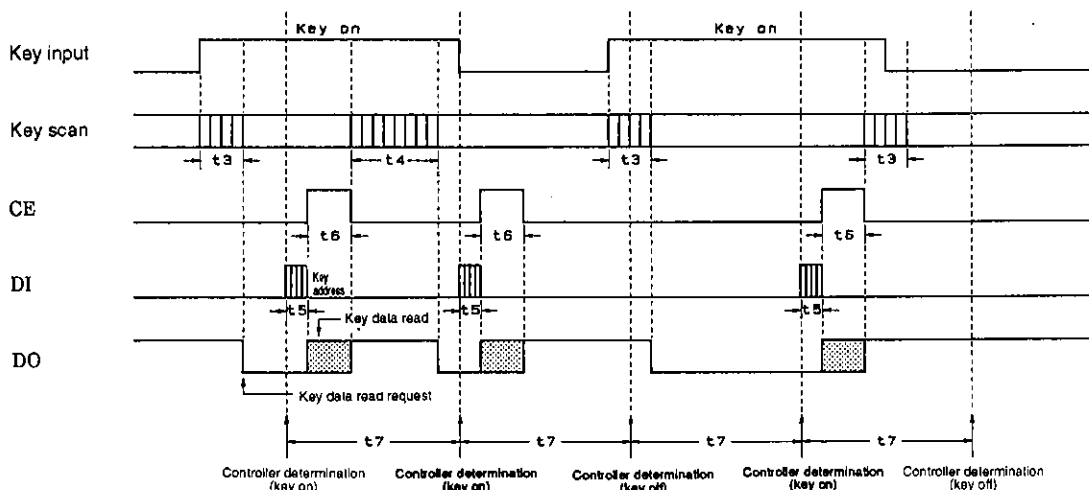

A03717

t3: Key scan execution time when the key data agreed for two key scans. (800 T (s))

t4: Key scan execution time when the key data did not agree for two key scans and the key scan was executed again. (1600 T (s))

$$T = \frac{1}{f_{OSC}}$$

t5: Key address (43H) transfer time

t6: Key data read time

• Explanation

In this technique, the controller uses a timer to determine key on/off states and read the key data. The controller must check the DO state when CE is low every t7 period without fail. If DO is low, the controller recognizes that a key has been pressed and executed the key data read operation.

The period t7 in this technique must satisfy the following condition.

$$t7 > (t5 + t6 + t4)$$

If a key data read operation is executed when DO is high, the read key data (KD1 to KD30) and sleep acknowledge data (SA) will be invalid.

2. Interrupt based key data acquisition

• Flowchart

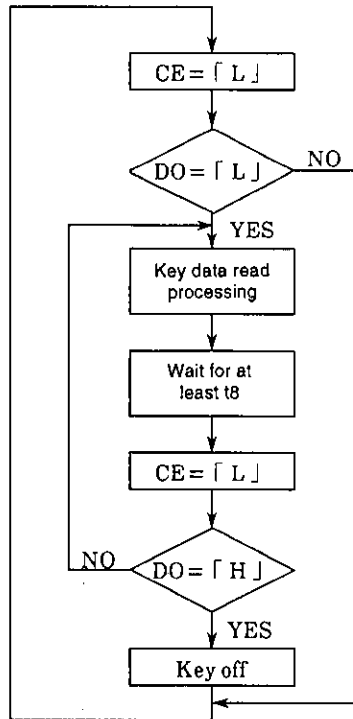

• Timing chart

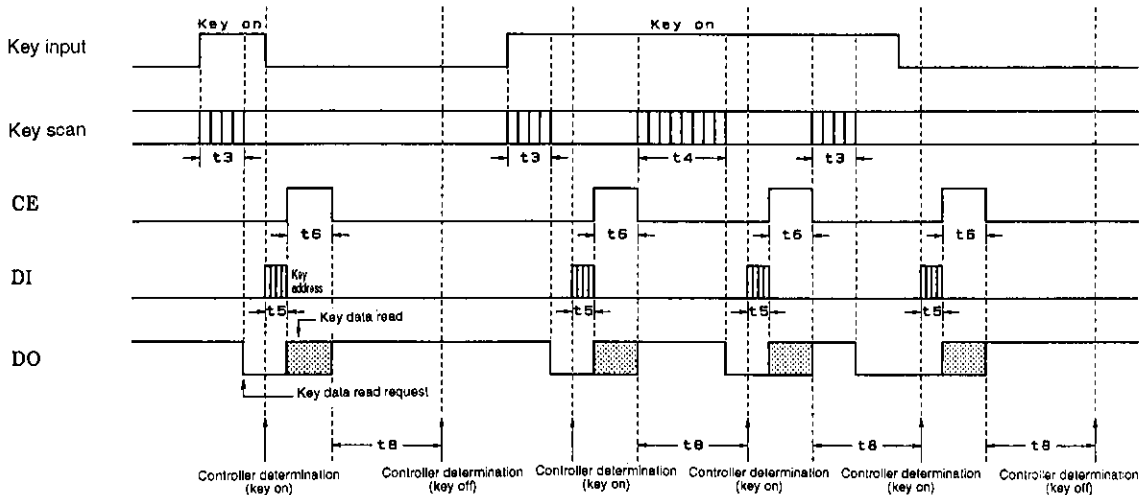

A03718

t3: Key scan execution time when the key data agreed for two key scans. (800 T (s))

t4: Key scan execution time when the key data did not agree for two key scans and the key scan was executed again. (1600 T (s))

$$T = \frac{1}{f_{OSC}}$$

t5: Key address (43H) transfer time

t6: Key data read time

- Explanation

In this technique, the controller uses interrupts to determine key on/off states and read the key data. The controller must check the DO state when CE is low. If DO is low, the controller recognizes that a key has been pressed and executes the key data read operation. After that the next key on/off determination is performed after the time t_8 has elapsed by checking the DO state when CE is low and reading the key data. The period t_8 in this technique must satisfy the following condition.

$$t_8 > t_4$$

If a key data read operation is executed when DO is high, the read key data (KD1 to KD30) and sleep acknowledge data (SA) will be invalid.

- No products described or contained herein are intended for use in surgical implants, life-support systems, aerospace equipment, nuclear power control systems, vehicles, disaster/crime-prevention equipment and the like, the failure of which may directly or indirectly cause injury, death or property loss.
- Anyone purchasing any products described or contained herein for an above-mentioned use shall:
 - ① Accept full responsibility and indemnity and defend SANYO ELECTRIC CO., LTD., its affiliates, subsidiaries and distributors and all their officers and employees, jointly and severally, against any and all claims and litigation and all damages, cost and expenses associated with such use:
 - ② Not impose any responsibility for any fault or negligence which may be cited in any such claim or litigation on SANYO ELECTRIC CO., LTD., its affiliates, subsidiaries and distributors or any of their officers and employees jointly or severally.
- Information (including circuit diagrams and circuit parameters) herein is for example only; it is not guaranteed for volume production. SANYO believes information herein is accurate and reliable, but no guarantees are made or implied regarding its use or any infringements of intellectual property rights or other rights of third parties.

This catalog provides information as of November, 1995. Specifications and information herein are subject to change without notice.