

Photon Dream Internal Document
 Not for public release! The information on this page is unofficial and not verified. Use at your own risk!

Handy CTI 678xx to DT-40 Pro cross-reference.
 The 40 Pro lacks official test points, this document details the R.E. undertaken to find the appropriate locations and labels to assist tuning the 40 Pro using standard CTI's 678xx practices.

DT4XXX / 678XX
Cross-Reference Circuit

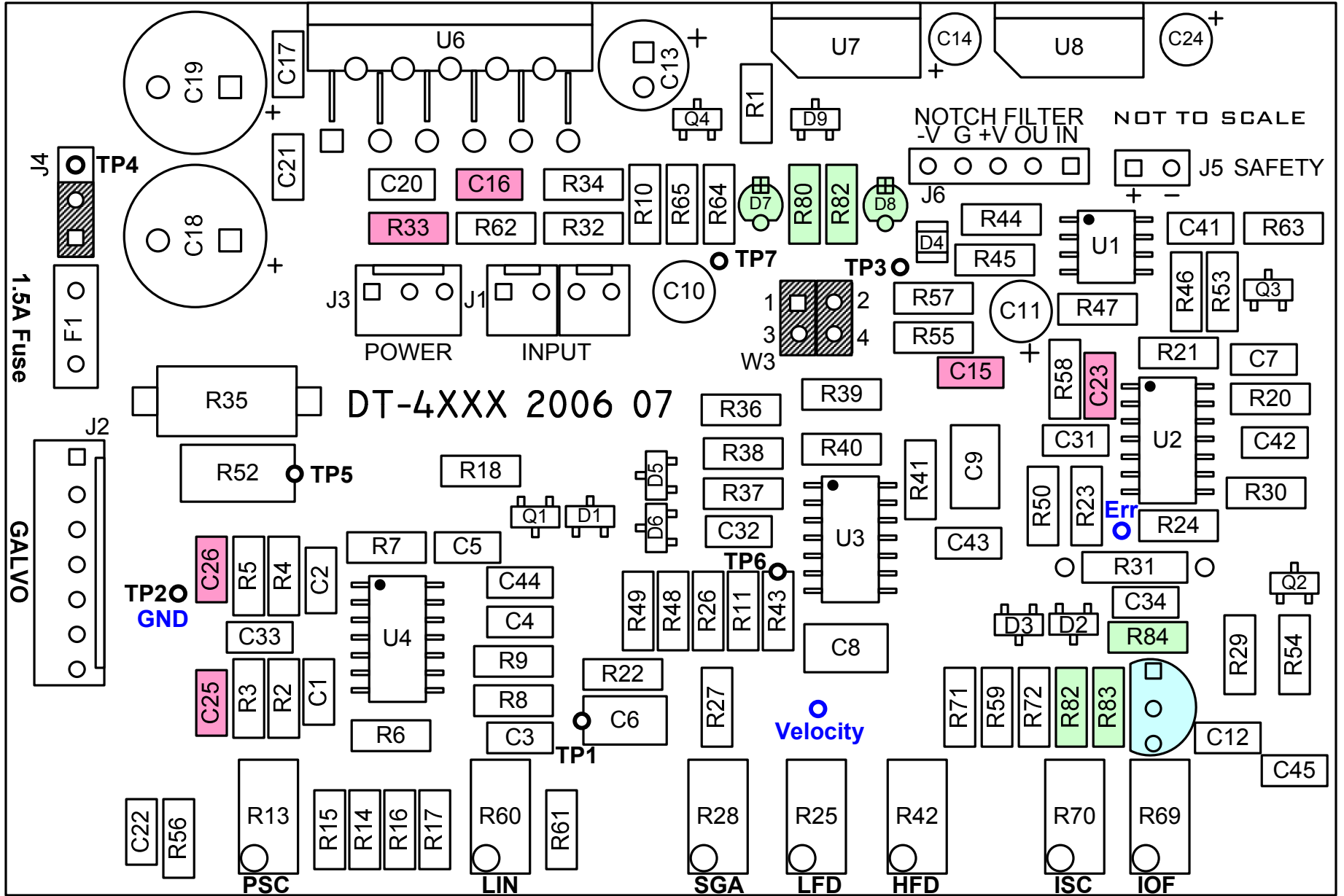

U1	RC4200 Analog Multiplier	R1	10k Ohm (103) [NEED 12k]	R53	6.2k Ohm (622) [NEED 6.04k]
U2	TL074C JFET Quad OpAmp	R2	51.0k Ohm (5102)	R54	100k Ohm (104)
U3	TL074C JFET Quad OpAmp	R3	300 Ohm (301)	R55	200k Ohm (204)
U4	TL074C JFET Quad OpAmp	R4	51.0k Ohm (5102)	R56	20k Ohm (203)
U5	TL431 Shunt Regulator	R5	300 Ohm (301) [Verify this on CT 3k?]	R57	200k Ohm (204)
U6	LM3886TF Power Amplifier	R6	6.8k Ohm (682)	R58	200k Ohm (204)
U7	7815 +15V Voltage Regulator	R7	6.8k Ohm (682)	R59	1k Ohm (102)
U8	7915 -15V Voltage Regulator	R8	10k Ohm (103)	R60	10k Ohm Pot (103)
		R9	10k Ohm (103)	R61	51k Ohm (5102)
Q1	MMBT3904L	R10	10 Ohm (100)	R62	4.7k Ohm (472)
Q2	MMBF4392L (SOT23)	R11	100k Ohm (104)	R63	7.5k (752) [NEED 7.68k Ohm]
Q3	MMBT3906L (SOT23)	R12	Need to create, 1k	R64	4.7k Ohm (472) [NEED 4.5k]
Q4	MMBT3906L (SOT23)	R13	20k Ohm Pot (203)	R65	6.2k Ohm (622) [NEED 6k]
		R14	51.0k Ohm (5102)	R66	Need to create, 6k for MUTE
C1	?	R15	10k Ohm (103)	R67	Need to create, 1k for Velocity
C2	?	R16	10k Ohm (103)	R68	Need to create, 1k for Error
C3	?	R17	10k Ohm (103)	R69	10k Ohm Pot (103)
C4	?	R18	150 Ohm (151)	R70	10k Ohm Pot (103) [NEED 1k]
C5	0.1 uF	R19	See R52	R71	4.7k Ohm (472)
C6	??	R20	10k Ohm (103)	R72	1.50k Ohm (152)
C7	?	R21	1.5k Ohm (152)	R73	Need to create, 100k Ohm for TP6
C8	??	R22	110k Ohm (114)		
C9	???	R23	100k Ohm (104)	R80	1k Ohm (102) for LEDs
C10	300 pF (331)	R24	1k Ohm (102)	R81	1k Ohm (102) for LEDs
C11	Tantalum 25V 4.7 uF (4u7-25)	R25	10k Ohm Pot (103)	R82	3k Ohm (302) for Shunt Reg
C12	0.1 uF	R26	4.7k Ohm (472)	R83	1k Ohm (102) for Shunt Reg
C13	Electrolytic 25V 47 uF [NEED 100 uF]	R27	2.2k Ohm (222)	R84	510 Ohm (511) for Shunt Reg
C14	Pol. 35V 2.2 uF	R28	10k Ohm Pot (103)	D1	MMBD914L H.S. Switching Diode
C15	Missing!	R29	10k Ohm Pot (103)	D2	MMBD914L H.S. Switching Diode
C16	Missing!	R30	10k Ohm Pot (103)	D3	MMBD914L H.S. Switching Diode
C17	0.1 uF	R31	62k Ohm (623K)	D4	RB501V-40 Schottky Barrier Diode
C18	Electrolytic 35V 470 uF	R32	15k Ohm (153)	D5	MMBD914L H.S. Switching Diode
C19	Electrolytic 35V 470 uF	R33	150k Ohm Missing! (1503)	D6	MMBD914L H.S. Switching Diode
C20	22 pF (22)	R34	33k Ohm (333)	D7	LED
C21	0.1 uF	R35	0.1 Ohm (R10)	D8	LED
C22	0.1 uF	R36	100 Ohm (101)	D9	MMBD914L H.S. Switching Diode
C23	Missing!	R37	2k Ohm (202)		
C24	Ceramic 35V 2.2 uF	R38	100 Ohm (101)	J1	Command (Differential Signal) Input
C25	Missing!	R39	2k Ohm (202)	J2	Galvanometer Output
C26	Missing!	R40	3.3k Ohm (332)	J3	Power Input
C31	0.1 uF	R41	120k Ohm (124)	J4	Motor/Fuse Bypass
C32	0.1 uF	R42	100k Ohm Pot (104) HFD	J5	Commanded Input Signal (Safety)
C33	0.1 uF	R43	3.6K Ohm (362)	J6	Notch Filter
C34	0.1 uF	R44	10k Ohm (103)	J7	Virtual Test Header (J4 on Camtech 678)
C41	0.1 uF	R45	10k Ohm (103)		
C42	0.1 uF	R46	20k Ohm (203)		
C43	0.1 uF	R47	47.5k Ohm (473)		
C44	0.1 uF	R48	2.2k Ohm (222)		
C45	0.1 uF	R49	680 Ohm (681)		
		R50	200k Ohm (204) [NEED 196K]		
F1	1.5A Fuse	R51	(see R52)		
		R52	300 Ohm (301)		

Note: On the DT-4XXX board some of the components have been substituted with approximate values. I have marked them in **RED** along with components which are absent for the purpose of cost reduction. Some of the components used for tuning are also missing, I marked those in **BLUE**.

Photon Dream Internal Document
 Not for public release! The information on this page is unofficial and not verified. Use at your own risk!

Handy CTI 678xx to DT-40 Pro cross-reference.
 The 40 Pro lacks official test points, this document details the R.E. undertaken to find the appropriate locations and labels to assist tuning the 40 Pro using standard CTI's 678xx practices.

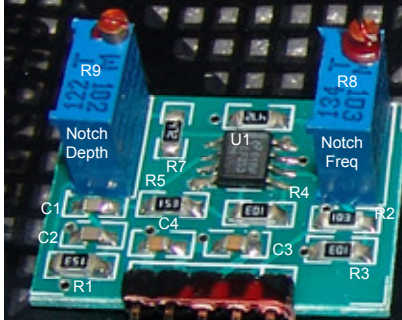

B = Bandwidth
 Wr = Resonant Frequency
 Ar = Gain at Wr

C1 = C2 = C
 Q = Wr / B
 R5 = 2 / BC
 R1 = R5 / 2Ar
 "R6" = R5 / (4Q² - 2Ar)

TP4
 Use J4 or
 Clip to Fuse

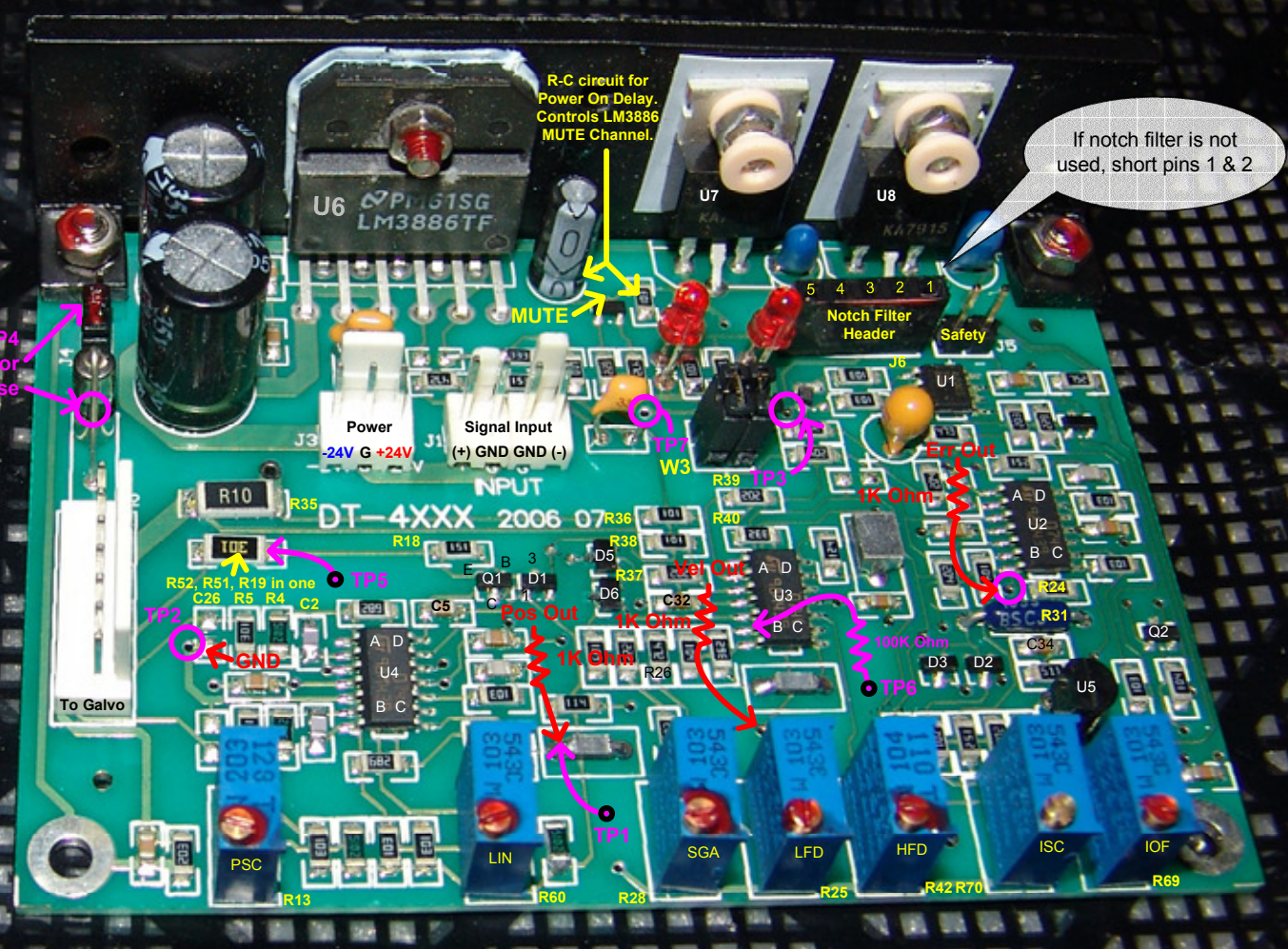

678xx EQUIV TEST POINTS

- TP1 - Position Signal, VP
- TP2 - Ground
- TP3 - Current Monitor
- TP4 - Motor Voltage, +M
- TP5 - AGC Out
- TP6 - Summing Amp Input
- TP7 - Notch Filter Output

JUMPERS

- J1 - Differential Signal Input (+, GND, GND, -)
- J2 - Galvanometer Output
- J3 - Power Input (-24V, GND, +24V)
- J4 - Fuse Bypass
- J5 - Safety (Commanded Input Signal)
- J6 - 5 Pin Notch Filter (In, Out, +15, GND, -15)
- W3 - Input Invert/NonInvert jumper pair

TUNABLE INPUTS

- PSC - Position Detect Scale Factor
- LIN - Position Detect Linearity
- SGA - Servo Gain
- LFD - Low Frequency Dampening
- HFD - High Frequency Dampening
- ISC - Input Scale Factor
- IOF - Input Position Offset