

# Ultra-Fast-Recovery Rectifier Diodes 200V

trr ①: I<sub>F</sub>/I<sub>R</sub>(=I<sub>F</sub>) 90% Recovery Point  
 (ex. I<sub>F</sub>/I<sub>R</sub> = 100mA/100mA 90% Recovery Point)  
 trr ②: I<sub>F</sub>/I<sub>R</sub>(=2 I<sub>F</sub>) 75% Recovery Point  
 (ex. I<sub>F</sub>/I<sub>R</sub> = 100mA/200mA 75% Recovery Point)

V <sub>RM</sub> (V)	Package	Part Number	I <sub>F</sub> (AV) (A)	I <sub>FSM</sub> (A)	T <sub>j</sub> (°C)	T <sub>stg</sub> (°C)	V <sub>F</sub> (V)	I <sub>F</sub> (A)	I <sub>R</sub> (μA)	I <sub>R</sub> (H) (mA)	T <sub>a</sub> (°C)	trr ① (ns)		trr ② (ns)		R <sub>th</sub> (j-ℓ) R <sub>th</sub> (j-c) (°C/W)	Mass (g)	Fig. No.	Page where characteristic curve is shown
				50Hz Half-cycle Sinewave Single Shot					V <sub>R</sub> =V <sub>RM</sub> max	V <sub>R</sub> =V <sub>RM</sub> max		I <sub>F</sub> /I <sub>FP</sub> (mA)	I <sub>F</sub> /I <sub>FP</sub> (mA)						
200	Surface Mount	SFPL-52	0.9	25	-40 to +150	0.98	1.0	10	1	150 (Tj)	50	100/100	35	100/200	20	0.072	1	63	
		SFPL-62	1.0	25	-40 to +150	0.98	1.0	10	1	150 (Tj)	50	100/100	35	100/200	20	0.072			
		SFPX-62	1.5	30	-40 to +150	0.98	1.5	10	2	150 (Tj)	30	100/100	25	100/200	20	0.072			
		SPX-G32S	3.0	50	-40 to +150	0.98	3.0	50	10	100	30	100/100	25	100/200	5.0	0.41	2	64	
		MPL-102S	10.0	65	-40 to +150	0.98	5.0	100	0.2	150	40	100/100	30	100/200	2.5	1.4	15	80	
	Surface Mount Center-tap	SPX-62S	6.0	80	-40 to +150	0.98	3.0	50	10	100	30	100/100	25	100/200	5.0	0.41	2	64	
		MP2-202S	20.0	110	-40 to +150	0.98	10.0	200	0.4	150	50	100/100	35	100/200	2.5	1.4	15	80	
	Axial	AG01Z	0.7	15	-40 to +150	1.8	0.7	100	0.5	100	100	100/100	50	100/200	22	0.13	3	64	
		EG01Z	0.7	15	-40 to +150	1.9	0.7	50	0.3	100	100	100/100	50	100/200	20	0.2	4		
		EG 1Z	0.8	15	-40 to +150	1.7	0.8	50	0.3	100	100	100/100	50	100/200	17	0.3	5	65	
		AL01Z	1.0	25	-40 to +150	0.98	1.0	100	0.5	100	50	100/100	35	100/200	22	0.13	3	64	
		EN01Z	1.0	50	-40 to +150	0.92	1.0	10	2	150 (Tj)	100	100/100	50	100/200	20	0.2	4	65	
		RG 10Z	1.2	50	-40 to +150	1.5	1.2	500	2.5	100	100	100/100	50	100/200	15	0.4	6	66	
		RG 2Z	1.2	50	-40 to +150	1.5	1.5	500	2.5	100	100	100/100	50	100/200	12	0.6	7	68	
		EL02Z	1.5	25	-40 to +150	0.98	1.5	50	0.1	100	40	100/100	30	100/200	20	0.2	4	65	
		EL 1Z	1.5	20	-40 to +150	0.98	1.5	100	0.5	100	100	100/100	50	100/200	17	0.3	5	66	
		RN 1Z	1.5	60	-40 to +150	0.92	1.5	20	3	150 (Tj)	100	100/100	50	100/200	15	0.4	6	67	
		RX 10Z *	2.0	30	-40 to +150	0.98	2.0	50	3	150 (Tj)	30	100/100	25	100/200	15	0.4		80	
		RL 10Z	2.0	30	-40 to +150	0.98	2.0	50	0.1	100	50	100/100	35	100/200	15	0.4	7	67	
		RL 2Z	2.0	30	-40 to +150	0.98	2.0	100	0.5	100	50	100/100	35	100/200	12	0.6		68	
		RN 2Z	2.0	70	-40 to +150	0.92	2.0	50	4	150 (Tj)	100	100/100	50	100/200	12	0.6	8	69	
		RN 3Z	3.0	80	-40 to +150	0.92	3.0	50	6	150 (Tj)	100	100/100	50	100/200	10	1.0		70	
		RX 3Z	3.0	80	-40 to +150	0.98	3.0	50	10	100	30	100/100	25	100/200	10	1.0	9	71	
		RG 4Z	1.0 (3.0)	80	-40 to +150	1.7	3.0	1000	5	100	100	100/100	35	100/200	8	1.2			
		RL 3Z	3.5	80	-40 to +150	0.95	3.5	50	0.2	100	50	100/100	35	100/200	10	1.0	8	69	
	RL 4Z	3.5	80	-40 to +150	0.95	3.5	150	0.5	100	50	100/100	50	100/200	8	1.2				
	RN 4Z	3.5	120	-40 to +150	0.92	3.5	50	6	150 (Tj)	100	100/100	50	100/200	8	1.2	9	71		
	Frame-2Pin	FML-G12S	5.0	65	-40 to +150	0.98	5.0	250	1	100	40	100/100	30	100/200	4.0			2.1	10
		FMN-G12S	5.0	100	-40 to +150	0.92	5.0	100	10	100	100	100/100	50	100/200	4.0	2.1			
		FMP-G12S	5.0	65	-40 to +150	1.15	5.0	50	0.5	100	150	100/100	70	100/200	4.0	2.1			
FMX-G12S		5.0	65	-40 to +150	0.98	5.0	100	20	100	30	100/100	25	100/200	4.0	2.1				
FML-G22S		10.0	150	-40 to +150	0.98	10.0	500	2	100	40	500/500	30	500/1000	4.0	2.1				
FMX-G22S		10.0	150	-40 to +150	0.98	10.0	200	50	100	30	500/500	25	500/1000	4.0	2.1				
Center-tap	FMG-12S, R	5.0	35	-40 to +150	1.8	2.5	500	1.5	100	100	100/100	50	100/200	4.0	2.1	11	74		
	FML-12S	5.0	35	-40 to +150	0.98	2.5	150	0.5	100	40	100/100	30	100/200	4.0	2.1		75		
	FMX-12S	5.0	35	-40 to +150	0.98	2.5	50	10	100	30	100/100	25	100/200	4.0	2.1		77		
	FMG-22S, R	10.0	65	-40 to +150	1.8	5.0	500	1.5	100	100	100/100	50	100/200	4.0	2.1	11	75		
	FML-22S	10.0	65	-40 to +150	0.98	5.0	250	1	100	40	100/100	30	100/200	4.0	2.1		76		
	FMX-22S	10.0	65	-40 to +150	0.98	5.0	100	20	100	30	100/100	25	100/200	4.0	2.1		11	77	
	FMX-22SL	15.0	100	-40 to +150	0.98	7.5	150	30	100	30	500/500	25	500/1000	4.0	2.1				
	FMG-32S, R	20.0	150	-40 to +150	1.8	10.0	1000	5	100	100	100/100	50	100/200	2.0	5.5	12		78	
	FML-32S	20.0	150	-40 to +150	0.98	10.0	600	2	100	40	100/100	30	100/200	2.0	5.5				
FMX-32S	20.0	150	-40 to +150	0.98	10.0	200	50	100	30	500/500	25	500/1000	2.0	5.5					
Bridge	RBV-402L	4.0	80	-40 to +150	0.98	2.0	50	0.1	100	40	100/100	30	100/200	5.0	4.05	13	79		
	RBV-602L	6.0	100	-40 to +150	1.0	3.0	250	1	100	50	100/100	35	100/200	3.0	6.45	13			

\* : Under development

# Ultra-Fast-Recovery Rectifier Diodes 200V

## External Dimensions Flammability: UL94V-0 or Equivalent (Unit: mm)

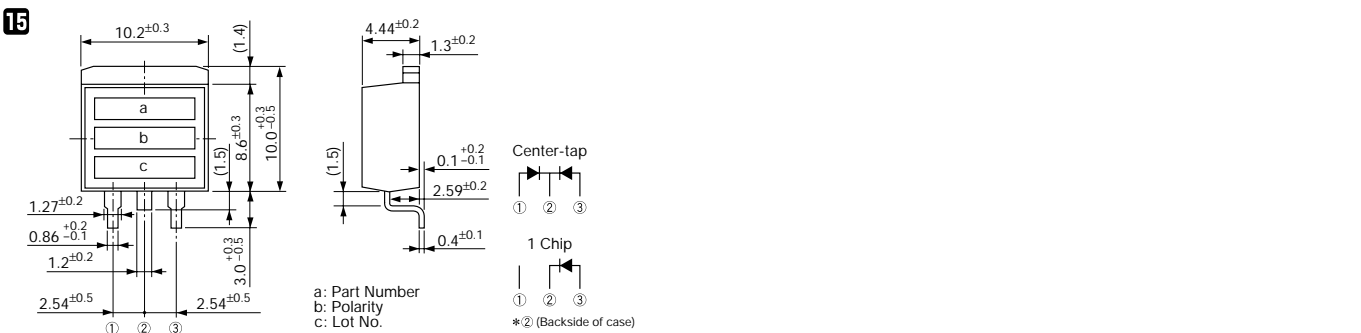
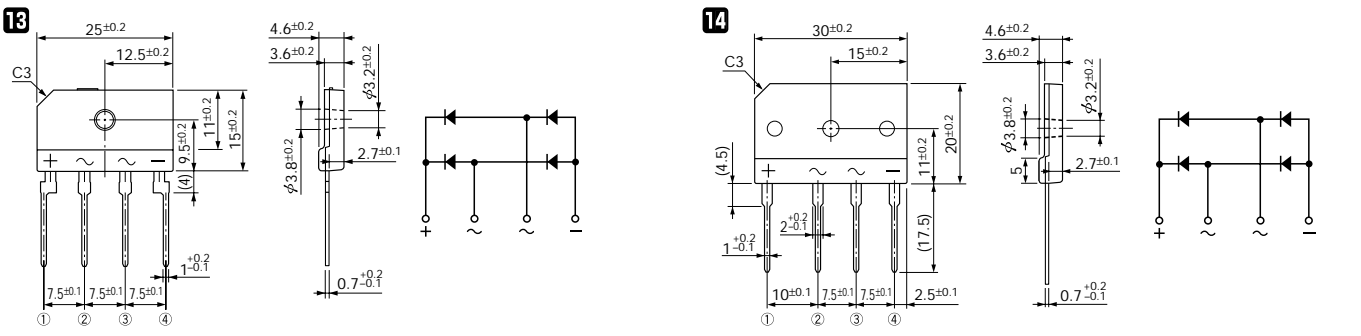
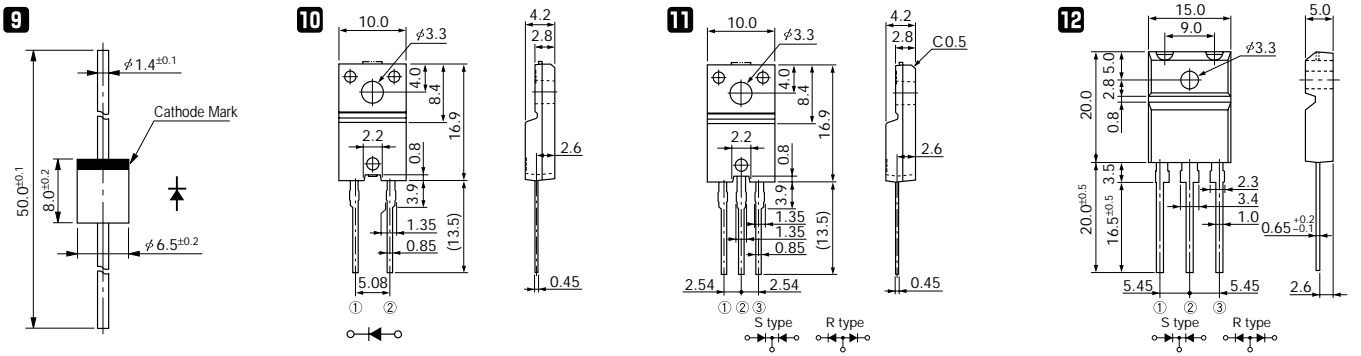
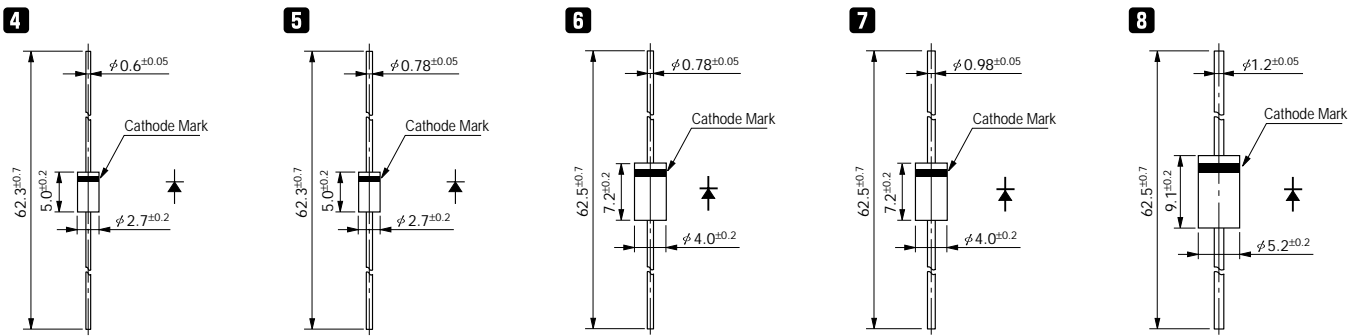
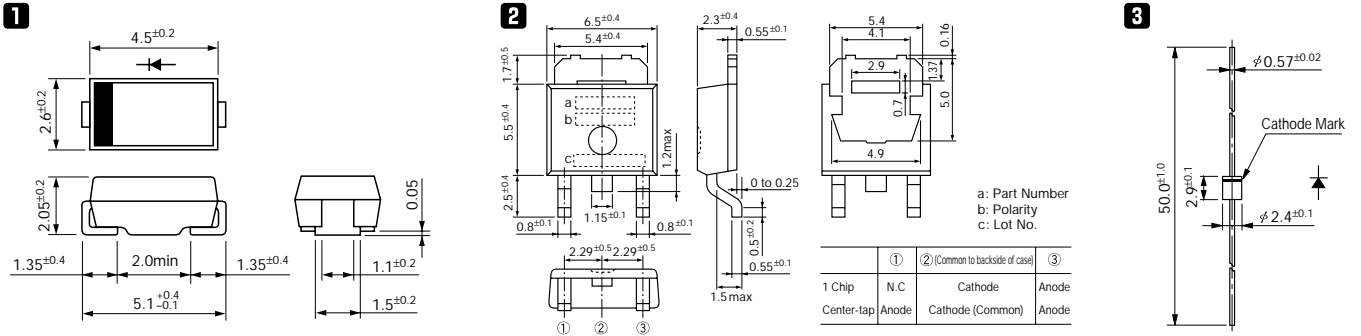

# Ultra-Fast-Recovery Rectifier Diodes

## RL 4Z

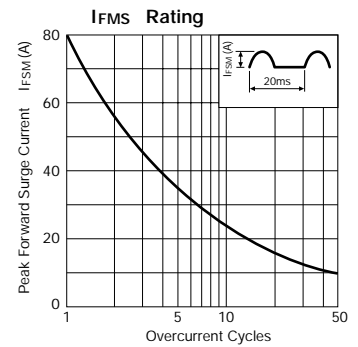
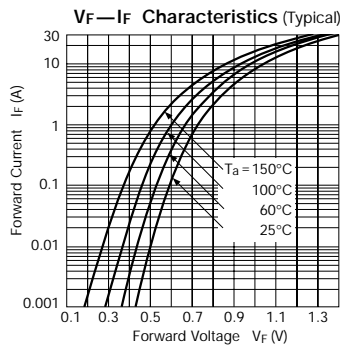
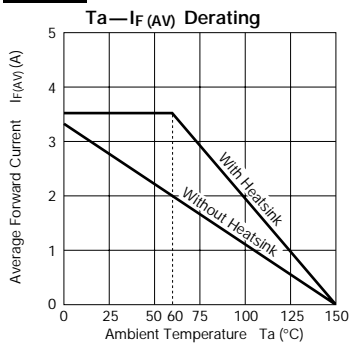

## RL 4A

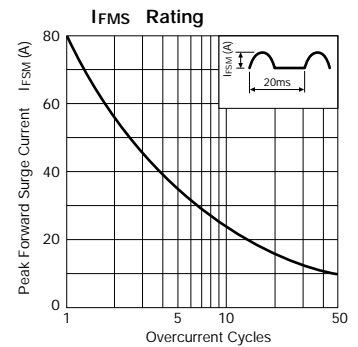
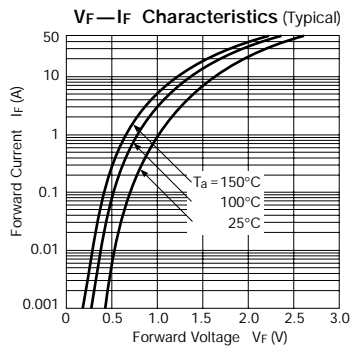
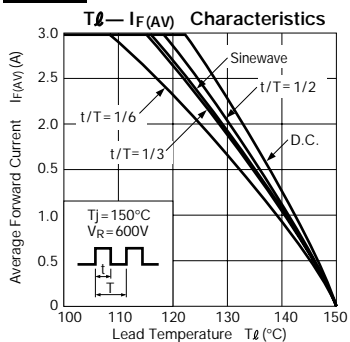

## RN 4Z

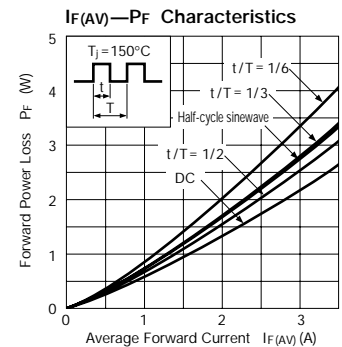
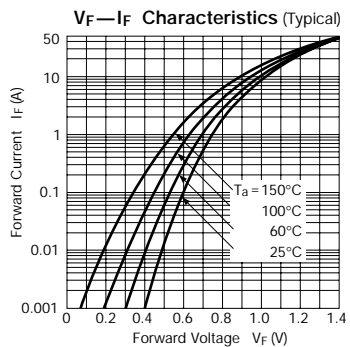
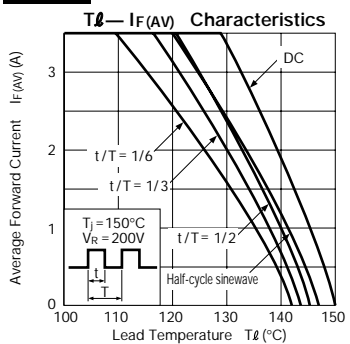

## FMC-G28S

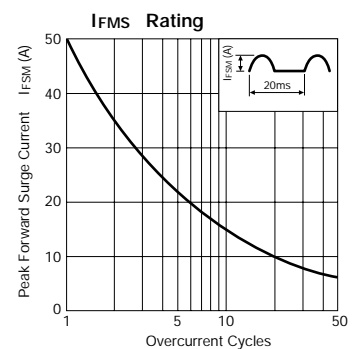
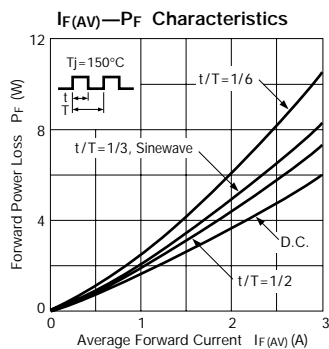
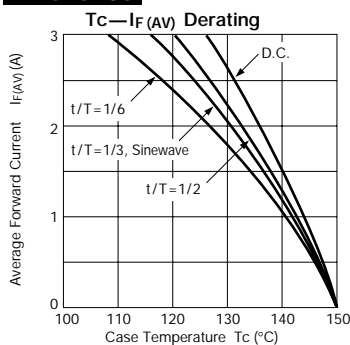

## FMC-G28SL

