

SIEMENS

SIMATIC

Statement List (STL) for S7-300 and S7-400 Programming

Reference Manual

This manual is part of the documentation
package with the order number:
6ES7810-4CA08-8BW1

Edition 03/2003
A5E00706960-01

Preface, Contents	
<hr/>	
Bit Logic Instructions	1
<hr/>	
Comparison Instructions	2
<hr/>	
Conversion Instructions	3
<hr/>	
Counter Instructions	4
<hr/>	
Data Block Instructions	5
<hr/>	
Logic Control Instructions	6
<hr/>	
Integer Math Instructions	7
<hr/>	
Floating-Point Math Instructions	8
<hr/>	
Load and Transfer Instructions	9
<hr/>	
Program Control Instructions	10
<hr/>	
Shift and Rotate Instructions	11
<hr/>	
Timer Instructions	12
<hr/>	
Word Logic Instructions	13
<hr/>	
Accumulator Instructions	14
<hr/>	
Appendices	
<hr/>	
Overview of All STL Instructions	A
<hr/>	
Programming Examples	B
<hr/>	
Parameter Transfer	C
<hr/>	
Index	

Safety Guidelines

This manual contains notices you have to observe in order to ensure your personal safety, as well as to prevent damage to property. The notices referring to your personal safety are highlighted in the manual by a safety alert symbol, notices referring to property damage only have no safety alert symbol. The notices shown below are graded according to the degree of danger.



Danger

indicates that death or severe personal injury **will** result if proper precautions are not taken.



Warning

indicates that death or severe personal injury **may** result if proper precautions are not taken.



Caution

with a safety alert symbol indicates that minor personal injury can result if proper precautions are not taken.

Caution

without a safety alert symbol indicates that property damage can result if proper precautions are not taken.

Notice

indicates that an unintended result or situation can occur if the corresponding notice is not taken into account.

If more than one degree of danger is present, the warning notice representing the highest degree of danger will be used. A notice warning of injury to persons with a safety alert symbol may also include a warning relating to property damage.

Qualified Personnel

The device/system may only be set up and used in conjunction with this documentation. Commissioning and operation of a device/system may only be performed by **qualified personnel**. Within the context of the safety notices in this documentation qualified persons are defined as persons who are authorized to commission, ground and label devices, systems and circuits in accordance with established safety practices and standards.

Prescribed Usage

Note the following:



Warning

This device and its components may only be used for the applications described in the catalog or the technical description, and only in connection with devices or components from other manufacturers which have been approved or recommended by Siemens.

Correct, reliable operation of the product requires proper transport, storage, positioning and assembly as well as careful operation and maintenance.

Trademarks

All names identified by ® are registered trademarks of the Siemens AG.

The remaining trademarks in this publication may be trademarks whose use by third parties for their own purposes could violate the rights of the owner.

Disclaimer of Liability

We have reviewed the contents of this publication to ensure consistency with the hardware and software described. Since variance cannot be precluded entirely, we cannot guarantee full consistency. However, the information in this publication is reviewed regularly and any necessary corrections are included in subsequent editions.

Preface

Purpose

This manual is your guide to creating user programs in the Statement List programming language STL.

The manual also includes a reference section that describes the syntax and functions of the language elements of STL.

Basic Knowledge Required

The manual is intended for S7 programmers, operators, and maintenance/service personnel.

In order to understand this manual, general knowledge of automation technology is required.

In addition to, computer literacy and the knowledge of other working equipment similar to the PC (e.g. programming devices) under the operating systems MS Windows 2000 Professional, XP Professional or MS Windows Server 2003 are required.

Scope of the Manual

This manual is valid for release 5.4 of the STEP 7 programming software package.

Compliance with Standards

STL corresponds to the "Instruction List" language defined in the International Electrotechnical Commission's standard IEC 1131-3, although there are substantial differences with regard to the operations. For further details, refer to the table of standards in the STEP 7 file NORM_TBL.WRI.

Requirements

To use the Statement List manual effectively, you should already be familiar with the theory behind S7 programs which is documented in the online help for STEP 7. The language packages also use the STEP 7 standard software, so you should be familiar with handling this software and have read the accompanying documentation.

This manual is part of the documentation package "STEP 7 Reference".

The following table displays an overview of the STEP 7 documentation:

Documentation	Purpose	Order Number
STEP 7 Basic Information with <ul style="list-style-type: none"> • Working with STEP 7, Getting Started Manual • Programming with STEP 7 • Configuring Hardware and Communication Connections, STEP 7 • From S5 to S7, Converter Manual 	Basic information for technical personnel describing the methods of implementing control tasks with STEP 7 and the S7-300/400 programmable controllers.	6ES7810-4CA08-8BW0
STEP 7 Reference with <ul style="list-style-type: none"> • Ladder Logic (LAD)/Function Block Diagram (FBD)/Statement List (STL) for S7-300/400 manuals • Standard and System Functions for S7-300/400 Volume 1 and Volume 2 	Provides reference information and describes the programming languages LAD, FBD, and STL, and standard and system functions extending the scope of the STEP 7 basic information.	6ES7810-4CA08-8BW1

Online Helps	Purpose	Order Number
Help on STEP 7	Basic information on programming and configuring hardware with STEP 7 in the form of an online help.	Part of the STEP 7 Standard software.
Reference helps on STL/LAD/FBD Reference help on SFBs/SFCs Reference help on Organization Blocks	Context-sensitive reference information.	Part of the STEP 7 Standard software.

Online Help

The manual is complemented by an online help which is integrated in the software. This online help is intended to provide you with detailed support when using the software.

The help system is integrated in the software via a number of interfaces:

- The context-sensitive help offers information on the current context, for example, an open dialog box or an active window. You can open the context-sensitive help via the menu command **Help > Context-Sensitive Help**, by pressing F1 or by using the question mark symbol in the toolbar.
- You can call the general Help on STEP 7 using the menu command **Help > Contents** or the "Help on STEP 7" button in the context-sensitive help window.
- You can call the glossary for all STEP 7 applications via the "Glossary" button.

This manual is an extract from the "Help on Statement List". As the manual and the online help share an identical structure, it is easy to switch between the manual and the online help.

Further Support

If you have any technical questions, please get in touch with your Siemens representative or responsible agent.

You will find your contact person at:

<http://www.siemens.com/automation/partner>

You will find a guide to the technical documentation offered for the individual SIMATIC Products and Systems here at:

<http://www.siemens.com/simatic-tech-doku-portal>

The online catalog and order system is found under:

<http://mall.automation.siemens.com/>

Training Centers

Siemens offers a number of training courses to familiarize you with the SIMATIC S7 automation system. Please contact your regional training center or our central training center in D 90327 Nuremberg, Germany for details:

Telephone: +49 (911) 895-3200.

Internet: <http://www.sitrain.com>

Technical Support

You can reach the Technical Support for all A&D products

- Via the Web formula for the Support Request
<http://www.siemens.com/automation/support-request>
- Phone: + 49 180 5050 222
- Fax: + 49 180 5050 223

Additional information about our Technical Support can be found on the Internet pages <http://www.siemens.com/automation/service>

Service & Support on the Internet

In addition to our documentation, we offer our Know-how online on the internet at:

<http://www.siemens.com/automation/service&support>

where you will find the following:

- The newsletter, which constantly provides you with up-to-date information on your products.
- The right documents via our Search function in Service & Support.
- A forum, where users and experts from all over the world exchange their experiences.
- Your local representative for Automation & Drives.
- Information on field service, repairs, spare parts and more under "Services".

Contents

1	Bit Logic Instructions	1-1
1.1	Overview of Bit Logic Instructions	1-1
1.2	A And	1-3
1.3	AN And Not.....	1-4
1.4	O Or.....	1-5
1.5	ON Or Not.....	1-6
1.6	X Exclusive Or	1-7
1.7	XN Exclusive Or Not.....	1-8
1.8	O And before Or	1-9
1.9	A(And with Nesting Open	1-10
1.10	AN(And Not with Nesting Open	1-11
1.11	O(Or with Nesting Open	1-11
1.12	ON(Or Not with Nesting Open	1-12
1.13	X(Exclusive Or with Nesting Open	1-12
1.14	XN(Exclusive Or Not with Nesting Open	1-13
1.15) Nesting Closed	1-14
1.16	= Assign	1-16
1.17	R Reset.....	1-17
1.18	S Set.....	1-18
1.19	NOT Negate RLO	1-19
1.20	SET Set RLO (=1)	1-20
1.21	CLR Clear RLO (=0).....	1-21
1.22	SAVE Save RLO in BR Register	1-22
1.23	FN Edge Negative	1-23
1.24	FP Edge Positive	1-25
2	Comparison Instructions	2-1
2.1	Overview of Comparison Instructions.....	2-1
2.2	? I Compare Integer (16-Bit).....	2-2
2.3	? D Compare Double Integer (32-Bit).....	2-3
2.4	? R Compare Floating-Point Number (32-Bit)	2-4
3	Conversion Instructions	3-1
3.1	Overview of Conversion Instructions	3-1
3.2	BTI BCD to Integer (16-Bit)	3-2
3.3	ITB Integer (16-Bit) to BCD	3-3
3.4	BTD BCD to Integer (32-Bit).....	3-4
3.5	ITD Integer (16 Bit) to Double Integer (32-Bit)	3-5
3.6	DTB Double Integer (32-Bit) to BCD	3-6
3.7	DTR Double Integer (32-Bit) to Floating-Point (32-Bit IEEE-FP)	3-7
3.8	INVI Ones Complement Integer (16-Bit).....	3-8
3.9	INVD Ones Complement Double Integer (32-Bit)	3-9
3.10	NEGI Twos Complement Integer (16-Bit).....	3-10
3.11	NEGD Twos Complement Double Integer (32-Bit).....	3-11
3.12	NEGR Negate Floating-Point Number (32-Bit, IEEE-FP).....	3-12
3.13	CAW Change Byte Sequence in ACCU 1-L (16-Bit)	3-13
3.14	CAD Change Byte Sequence in ACCU 1 (32-Bit).....	3-14
3.15	RND Round	3-15

3.16	TRUNC	Truncate	3-16
3.17	RND+	Round to Upper Double Integer	3-17
3.18	RND-	Round to Lower Double Integer	3-18
4	Counter Instructions		4-1
4.1		Overview of Counter Instructions	4-1
4.2	FR	Enable Counter (Free)	4-2
4.3	L	Load Current Counter Value into ACCU 1	4-3
4.4	LC	Load Current Counter Value into ACCU 1 as BCD	4-4
4.5	R	Reset Counter	4-5
4.6	S	Set Counter Preset Value	4-6
4.7	CU	Counter Up	4-7
4.8	CD	Counter Down	4-8
5	Data Block Instructions		5-1
5.1		Overview of Data Block Instructions	5-1
5.2	OPN	Open a Data Block	5-2
5.3	CDB	Exchange Shared DB and Instance DB	5-3
5.4	L DBLG	Load Length of Shared DB in ACCU 1	5-4
5.5	L DBNO	Load Number of Shared DB in ACCU 1	5-4
5.6	L DILG	Load Length of Instance DB in ACCU 1	5-5
5.7	L DINO	Load Number of Instance DB in ACCU 1	5-5
6	Logic Control Instructions		6-1
6.1		Overview of Logic Control Instructions	6-1
6.2	JU	Jump Unconditional	6-3
6.3	JL	Jump to Labels	6-4
6.4	JC	Jump if RLO = 1	6-5
6.5	JCN	Jump if RLO = 0	6-6
6.6	JCB	Jump if RLO = 1 with BR	6-7
6.7	JNB	Jump if RLO = 0 with BR	6-8
6.8	JBI	Jump if BR = 1	6-9
6.9	JNBI	Jump if BR = 0	6-10
6.10	JO	Jump if OV = 1	6-11
6.11	JOS	Jump if OS = 1	6-12
6.12	JZ	Jump if Zero	6-13
6.13	JN	Jump if Not Zero	6-14
6.14	JP	Jump if Plus	6-15
6.15	JM	Jump if Minus	6-16
6.16	JPZ	Jump if Plus or Zero	6-17
6.17	JMZ	Jump if Minus or Zero	6-18
6.18	JUO	Jump if Unordered	6-19
6.19	LOOP	Loop	6-20
7	Integer Math Instructions		7-1
7.1		Overview of Integer Math Instructions	7-1
7.2		Evaluating the Bits of the Status Word with Integer Math Instructions	7-2
7.3	+I	Add ACCU 1 and ACCU 2 as Integer (16-Bit)	7-3
7.4	-I	Subtract ACCU 1 from ACCU 2 as Integer (16-Bit)	7-4
7.5	*I	Multiply ACCU 1 and ACCU 2 as Integer (16-Bit)	7-5
7.6	/I	Divide ACCU 2 by ACCU 1 as Integer (16-Bit)	7-6
7.7	+	Add Integer Constant (16, 32-Bit)	7-8
7.8	+D	Add ACCU 1 and ACCU 2 as Double Integer (32-Bit)	7-10
7.9	-D	Subtract ACCU 1 from ACCU 2 as Double Integer (32-Bit)	7-11
7.10	*D	Multiply ACCU 1 and ACCU 2 as Double Integer (32-Bit)	7-12
7.11	/D	Divide ACCU 2 by ACCU 1 as Double Integer (32-Bit)	7-13
7.12	MOD	Division Remainder Double Integer (32-Bit)	7-15

8	Floating-Point Math Instructions	8-1
8.1	Overview of Floating-Point Math Instructions	8-1
8.2	Evaluating the Bits of the Status Word with Floating-Point Math Instructions..	8-2
8.3	Floating-Point Math Instructions: Basic	8-3
8.3.1	+R Add ACCU 1 and ACCU 2 as a Floating-Point Number (32-Bit IEEE-FP)	8-3
8.3.2	-R Subtract ACCU 1 from ACCU 2 as a Floating-Point Number (32-Bit IEEE-FP)	8-5
8.3.3	*R Multiply ACCU 1 and ACCU 2 as Floating-Point Numbers (32-Bit IEEE-FP)	8-7
8.3.4	/R Divide ACCU 2 by ACCU 1 as a Floating-Point Number (32-Bit IEEE-FP)	8-8
8.3.5	ABS Absolute Value of a Floating-Point Number (32-Bit IEEE-FP)	8-9
8.4	Floating-Point Math Instructions: Extended	8-10
8.4.1	SQR Generate the Square of a Floating-Point Number (32-Bit)	8-10
8.4.2	SQRT Generate the Square Root of a Floating-Point Number (32-Bit)	8-11
8.4.3	EXP Generate the Exponential Value of a Floating-Point Number (32-Bit)	8-12
8.4.4	LN Generate the Natural Logarithm of a Floating-Point Number (32-Bit)	8-13
8.4.5	SIN Generate the Sine of Angles as Floating-Point Numbers (32-Bit)	8-14
8.4.6	COS Generate the Cosine of Angles as Floating-Point Numbers (32-Bit)	8-15
8.4.7	TAN Generate the Tangent of Angles as Floating-Point Numbers (32-Bit)	8-16
8.4.8	ASIN Generate the Arc Sine of a Floating-Point Number (32-Bit)	8-17
8.4.9	ACOS Generate the Arc Cosine of a Floating-Point Number (32-Bit)	8-18
8.4.10	ATAN Generate the Arc Tangent of a Floating-Point Number (32-Bit)	8-19
9	Load and Transfer Instructions	9-1
9.1	Overview of Load and Transfer Instructions	9-1
9.2	L Load	9-2
9.3	L STW Load Status Word into ACCU 1	9-4
9.4	LAR1 Load Address Register 1 from ACCU 1	9-5
9.5	LAR1 <D> Load Address Register 1 with Double Integer (32-Bit Pointer)	9-6
9.6	LAR1 AR2 Load Address Register 1 from Address Register 2	9-7
9.7	LAR2 Load Address Register 2 from ACCU 1	9-7
9.8	LAR2 <D> Load Address Register 2 with Double Integer (32-Bit Pointer)	9-8
9.9	T Transfer	9-9
9.10	T STW Transfer ACCU 1 into Status Word	9-10
9.11	CAR Exchange Address Register 1 with Address Register 2	9-11
9.12	TAR1 Transfer Address Register 1 to ACCU 1	9-11
9.13	TAR1 <D> Transfer Address Register 1 to Destination (32-Bit Pointer)	9-12
9.14	TAR1 AR2 Transfer Address Register 1 to Address Register 2	9-13
9.15	TAR2 Transfer Address Register 2 to ACCU 1	9-13
9.16	TAR2 <D> Transfer Address Register 2 to Destination (32-Bit Pointer)	9-14
10	Program Control Instructions	10-1
10.1	Overview of Program Control Instructions	10-1
10.2	BE Block End	10-2
10.3	BEC Block End Conditional	10-3
10.4	BEU Block End Unconditional	10-4
10.5	CALL Block Call	10-5
10.6	Call FB	10-7
10.7	Call FC	10-9
10.8	Call SFB	10-11
10.9	Call SFC	10-13

10.10	Call Multiple Instance.....	10-14
10.11	Call Block from a Library.....	10-14
10.12	CC Conditional Call.....	10-15
10.13	UC Unconditional Call.....	10-16
10.14	MCR (Master Control Relay).....	10-17
10.15	Important Notes on Using MCR Functions.....	10-19
10.16	MCR(Save RLO in MCR Stack, Begin MCR.....	10-20
10.17)MCR End MCR.....	10-22
10.18	MCRA Activate MCR Area.....	10-23
10.19	MCRD Deactivate MCR Area.....	10-24
11	Shift and Rotate Instructions	11-1
11.1	Shift Instructions.....	11-1
11.1.1	Overview of Shift Instructions.....	11-1
11.1.2	SSI Shift Sign Integer (16-Bit).....	11-2
11.1.3	SSD Shift Sign Double Integer (32-Bit).....	11-4
11.1.4	SLW Shift Left Word (16-Bit).....	11-6
11.1.5	SRW Shift Right Word (16-Bit).....	11-8
11.1.6	SLD Shift Left Double Word (32-Bit).....	11-10
11.1.7	SRD Shift Right Double Word (32-Bit).....	11-12
11.2	Rotate Instructions.....	11-14
11.2.1	Overview of Rotate Instructions.....	11-14
11.2.2	RLD Rotate Left Double Word (32-Bit).....	11-15
11.2.3	RRD Rotate Right Double Word (32-Bit).....	11-17
11.2.4	RLDA Rotate ACCU 1 Left via CC 1 (32-Bit).....	11-19
11.2.5	RRDA Rotate ACCU 1 Right via CC 1 (32-Bit).....	11-20
12	Timer Instructions	12-1
12.1	Overview of Timer Instructions.....	12-1
12.2	Location of a Timer in Memory and Components of a Timer.....	12-2
12.3	FR Enable Timer (Free).....	12-5
12.4	L Load Current Timer Value into ACCU 1 as Integer.....	12-7
12.5	LC Load Current Timer Value into ACCU 1 as BCD.....	12-9
12.6	R Reset Timer.....	12-11
12.7	SP Pulse Timer.....	12-12
12.8	SE Extended Pulse Timer.....	12-14
12.9	SD On-Delay Timer.....	12-16
12.10	SS Retentive On-Delay Timer.....	12-18
12.11	SF Off-Delay Timer.....	12-20
13	Word Logic Instructions	13-1
13.1	Overview of Word Logic Instructions.....	13-1
13.2	AW AND Word (16-Bit).....	13-2
13.3	OW OR Word (16-Bit).....	13-4
13.4	XOW Exclusive OR Word (16-Bit).....	13-6
13.5	AD AND Double Word (32-Bit).....	13-8
13.6	OD OR Double Word (32-Bit).....	13-10
13.7	XOD Exclusive OR Double Word (32-Bit).....	13-12

14	Accumulator Instructions	14-1
14.1	Overview of Accumulator and Address Register Instructions	14-1
14.2	TAK Toggle ACCU 1 with ACCU 2	14-2
14.3	POP CPU with Two ACCUs	14-3
14.4	POP CPU with Four ACCUs	14-4
14.5	PUSH CPU with Two ACCUs	14-5
14.6	PUSH CPU with Four ACCUs	14-6
14.7	ENT Enter ACCU Stack	14-7
14.8	LEAVE Leave ACCU Stack	14-7
14.9	INC Increment ACCU 1-L-L	14-8
14.10	DEC Decrement ACCU 1-L-L	14-9
14.11	+AR1 Add ACCU 1 to Address Register 1	14-10
14.12	+AR2 Add ACCU 1 to Address Register 2	14-11
14.13	BLD Program Display Instruction (Null)	14-12
14.14	NOP 0 Null Instruction	14-12
14.15	NOP 1 Null Instruction	14-13
A	Overview of All STL Instructions	A-1
A.1	STL Instructions Sorted According to German Mnemonics (SIMATIC)	A-1
A.2	STL Instructions Sorted According to English Mnemonics (International)	A-7
B	Programming Examples	B-1
B.1	Overview of Programming Examples	B-1
B.2	Example: Bit Logic Instructions	B-2
B.3	Example: Timer Instructions	B-7
B.4	Example: Counter and Comparison Instructions	B-10
B.5	Example: Integer Math Instructions	B-12
B.6	Example: Word Logic Instructions	B-13
C	Parameter Transfer	C-1
Index		Index-1

1 Bit Logic Instructions

1.1 Overview of Bit Logic Instructions

Description

Bit logic instructions work with two digits, 1 and 0. These two digits form the base of a number system called the binary system. The two digits 1 and 0 are called binary digits or bits. In the world of contacts and coils, a 1 indicates activated or energized, and a 0 indicates not activated or not energized.

The bit logic instructions interpret signal states of 1 and 0 and combine them according to Boolean logic. These combinations produce a result of 1 or 0 that is called the "result of logic operation" (RLO).

Boolean bit logic applies to the following basic instructions:

- A And
- AN And Not
- O Or
- ON Or Not
- X Exclusive Or
- XN Exclusive Or Not
- O And before Or

You can use the following instructions to perform nesting expressions:

- A(And with Nesting Open
- AN(And Not with Nesting Open
- O(Or with Nesting Open
- ON(Or Not with Nesting Open
- X(Exclusive Or with Nesting Open
- XN(Exclusive Or Not with Nesting Open
-) Nesting Closed

You can terminate a Boolean bit logic string by using one of the following instructions:

- = Assign
- R Reset
- S Set

You can use one of the following instructions to change the result of logic operation (RLO):

- NOT Negate RLO
- SET Set RLO (=1)
- CLR Clear RLO (=0)
- SAVE Save RLO in BR Register

Other instructions react to a positive or negative edge transition:

- FN Edge Negative
- FP Edge Positive

1.2 A And

Format

A <Bit>

Address	Data type	Memory area
<Bit>	BOOL	I, Q, M, L, D, T, C

Description

A checks whether the state of the addressed bit is "1", and ANDs the test result with the RLO.







Status Word Bit Checks:

The **AND** instruction can also be used to directly check the status word by use of the following addresses: ==0, <>0, >0, <0, >=0, <=0, OV, OS, UO, BR.

Status word

	BR	CC 1	CC 0	OV	OS	OR	STA	RLO	/FC
writes:	-	-	-	-	-	x	x	x	1

Example

STL Program	Relay Logic
	Power rail 
A I 1.0	I 1.0 signal state 1  NO contact
A I 1.1	I 1.1 signal state 1  NC contact
= Q 4.0	Q 4.0 signal state 1  Coil
 Displays closed switch	

1.3 AN And Not

Format

N <Bit>

Address	Data type	Memory area
<Bit>	BOOL	I, Q, M, L, D, T, C

Description

AN checks whether the state of the addressed bit is "0", and ANDs the test result with the RLO.

The **AND NOT** instruction can also be used to directly check the status word by use of the following addresses: ==0, <>0, >0, <0, >=0, <=0, OV, OS, UO, BR.

Status word

	BR	CC 1	CC 0	OV	OS	OR	STA	RLO	/FC
writes:	-	-	-	-	-	x	x	x	1

Example

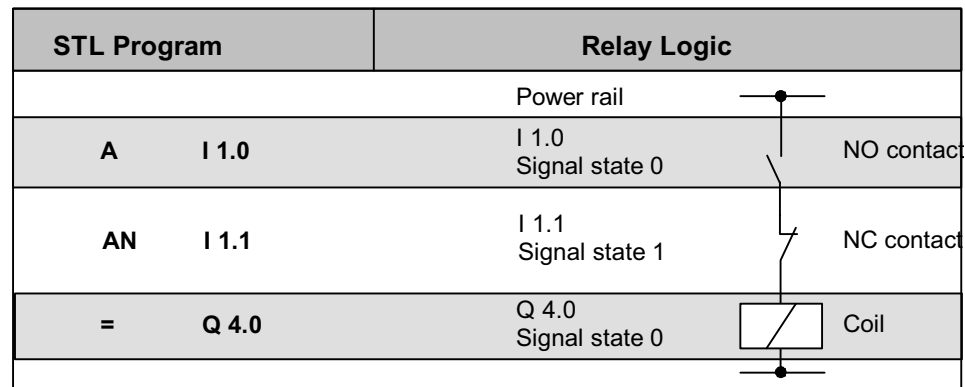

1.4 O Or

Format

O <Bit>

Address	Data type	Memory area
<Bit>	BOOL	I, Q, M, L, D, T, C

Description

O checks whether the state of the addressed bit is "1", and ORs the test result with the RLO.

Status Word Bit Checks:

The **OR** instruction can also be used to directly check the status word by use of the following addresses: ==0, <>0, >0, <0, >=0, <=0, OV, OS, UO, BR.

Status word

	BR	CC 1	CC 0	OV	OS	OR	STA	RLO	/FC
writes:	-	-	-	-	-	0	x	x	1

Example

STL Program	Relay Logic
O I 1.0	
O I 1.1	
= Q 4.0	

1.5 ON Or Not

Format

ON <Bit>

Address	Data type	Memory area
<Bit>	BOOL	I, Q, M, L, D, T, C

Description

ON checks whether the state of the addressed bit is "0", and ORs the test result with the RLO.

Status Word Bit Checks:

The **OR NOT** instruction can also be used to directly check the status word by use of the following addresses: ==0, <>0, >0, <0, >=0, <=0, OV, OS, UO, BR.

Status word

	BR	CC 1	CC 0	OV	OS	OR	STA	RLO	/FC
writes:									

Example

STL Program		Relay Logic	
		Power rail	
O	I 1.0	I 1.0 Signal state 0	NO contact
ON	I 1.1	I 1.1 Signal state 1	NC contact
=	Q 4.0	Q 4.0 Signal state 1	Coil

1.6 X Exclusive Or

Format

X <Bit>

Address	Data type	Memory area
<Bit>	BOOL	I, Q, M, L, D, T, C

Description

X checks whether the state of the addressed bit is "1", and XORs the test result with the RLO.

You can also use the **Exclusive OR** function several times. The mutual result of logic operation is then "1" if an impair number of checked addresses is "1".

Status Word Bit Checks:

The **EXCLUSIVE OR** instruction can also be used to directly check the status word by use of the following addresses: ==0, <>0, >0, <0, >=0, <=0, OV, OS, UO, BR.

Status word

	BR	CC 1	CC 0	OV	OS	OR	STA	RLO	/FC
writes:	-	-	-	-	-	0	x	x	1

Example

Statement List Program	Relay Logic
	Power rail
X I 1.0	Contact I 1.0
X I 1.1	Contact I 1.1
= Q 4.0	Q 4.0 Coil

1.7 XN Exclusive Or Not

Format

XN <Bit>

Address	Data type	Memory area
<Bit>	BOOL	I, Q, M, L, D, T, C

Description

XN checks whether the state of the addressed bit is "0", and XORs the test result with the RLO.





Status Word Bit Checks:

The **EXCLUSIVE OR NOT** instruction can also be used to directly check the status word by use of the following addresses: ==0, <>0, >0, <0, >=0, <=0, OV, OS, UO, BR.

Status word

	BR	CC 1	CC 0	OV	OS	OR	STA	RLO	/FC
writes:	-	-	-	-	-	0	x	x	1

Example

Statement List Program		Relay Logic	
		Power rail	
X	I 1.0	Contact I 1.0	
XN	I 1.1	Contact I 1.1	
=	Q 4.0	Q 4.0 Coil	

1.8 O And before Or

Format

O

Description

The **O** function performs a logical OR instruction on AND functions according to the rule: AND before OR.

Status word

	BR	CC 1	CC 0	OV	OS	OR	STA	RLO	/FC
writes:	-	-	-	-	-	x	1	-	x

Example

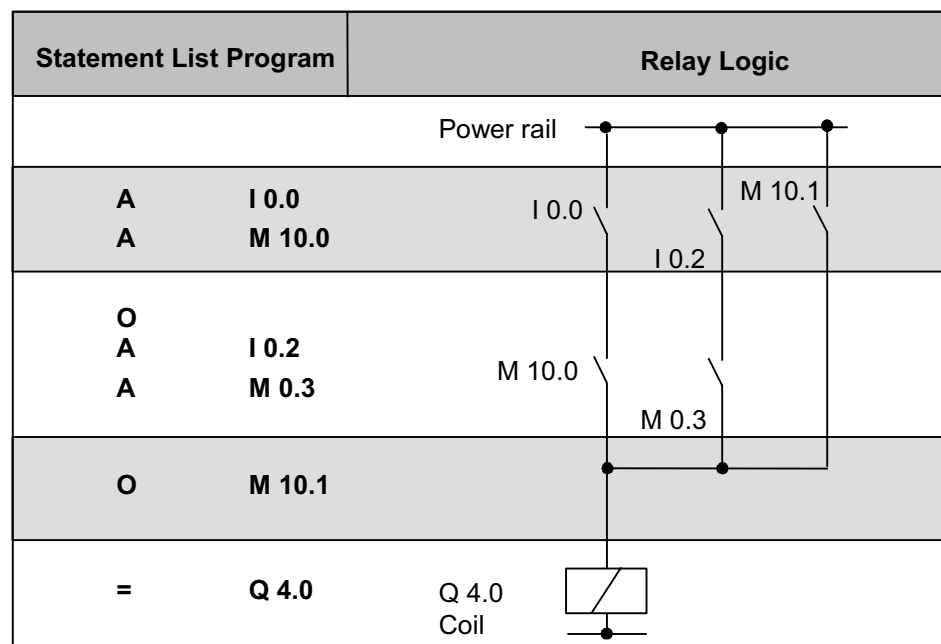

1.9 A(And with Nesting Open

Format

A(

Description

A((AND nesting open) saves the RLO and OR bits and a function code into the nesting stack. A maximum of seven nesting stack entries are possible.

Status word

	BR	CC 1	CC 0	OV	OS	OR	STA	RLO	/FC
writes:	-	-	-	-	-	0	1	-	0

Example

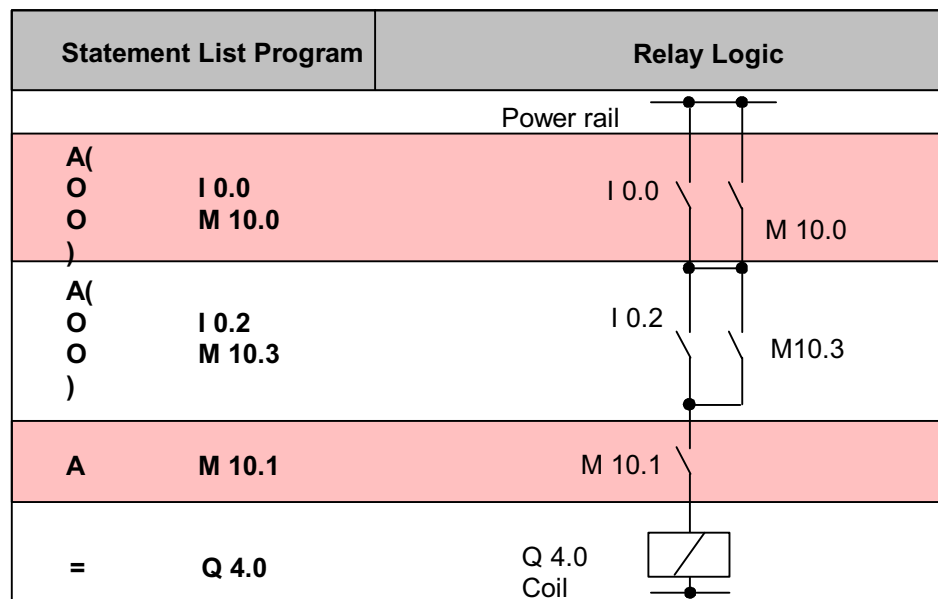

1.10 AN(And Not with Nesting Open

Format

AN(

Description

AN((AND NOT nesting open) saves the RLO and OR bits and a function code into the nesting stack. A maximum of seven nesting stack entries are possible.

Status word

	BR	CC 1	CC 0	OV	OS	OR	STA	RLO	/FC
writes:	-	-	-	-	-	0	1	-	0

1.11 O(Or with Nesting Open

Format

O(

Description

O((OR nesting open) saves the RLO and OR bits and a function code into the nesting stack. A maximum of seven nesting stack entries are possible.

Status word

	BR	CC 1	CC 0	OV	OS	OR	STA	RLO	/FC
writes:	-	-	-	-	-	0	1	-	0

1.12 ON(Or Not with Nesting Open

Format

ON(

Description

ON((OR NOT nesting open) saves the RLO and OR bits and a function code into the nesting stack. A maximum of seven nesting stack entries is possible.

Status word

	BR	CC 1	CC 0	OV	OS	OR	STA	RLO	/FC
writes:	-	-	-	-	-	0	1	-	0

1.13 X(Exclusive Or with Nesting Open

Format

X(

Description

X((XOR nesting open) saves the RLO and OR bits and a function code into the nesting stack. A maximum of seven nesting stack entries is possible.

Status word

	BR	CC 1	CC 0	OV	OS	OR	STA	RLO	/FC
writes:	-	-	-	-	-	0	1	-	0

1.14 XN(Exclusive Or Not with Nesting Open

Format

XN(

Description

XN((XOR NOT nesting open) saves the RLO and OR bits and a function code into the nesting stack. A maximum of seven nesting stack entries is possible.

Status word

	BR	CC 1	CC 0	OV	OS	OR	STA	RLO	/FC
writes:	-	-	-	-	-	0	1	-	0

1.15) Nesting Closed

Format

)

Description

) (nesting closed) removes an entry from the nesting stack, restores the OR bit, interconnects the RLO that is contained in the stack entry with the current RLO according to the function code, and assigns the result to the RLO. The OR bit is also included if the function code is "AND" or "AND NOT".

Statements which open parentheses groups:

- U(And with Nesting Open
- UN(And Not with Nesting Open
- O(Or with Nesting Open
- ON(Or Not with Nesting Open
- X(Exclusive Or with Nesting Open
- XN(Exclusive Or Not with Nesting Open

Status word

	BR	CC 1	CC 0	OV	OS	OR	STA	RLO	/FC
writes:	-	-	-	-	-	x	1	x	1

Example

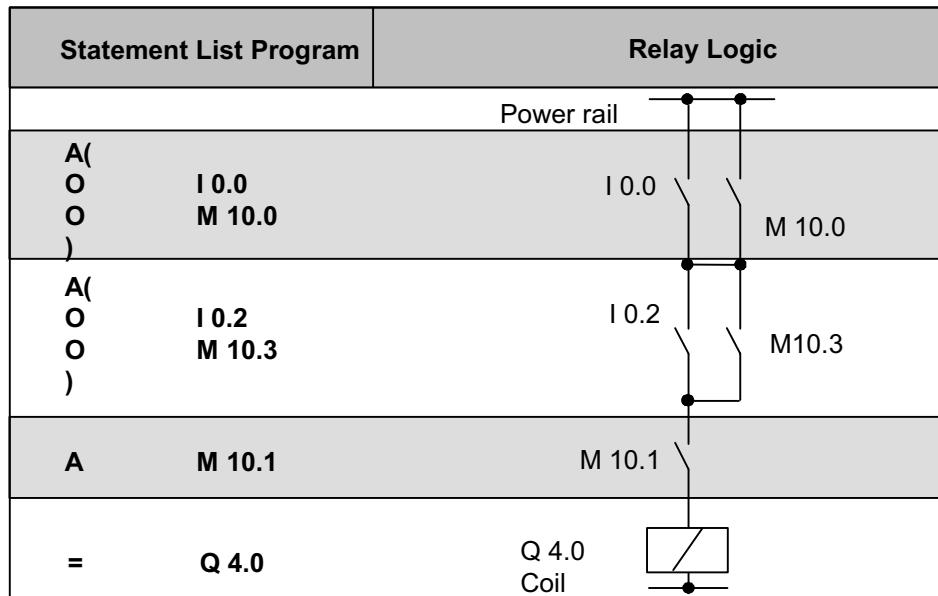

1.16 = Assign

Format

<Bit>

Address	Data type	Memory area
<Bit>	BOOL	I, Q, M, L, D

Description

= <Bit> writes the RLO into the addressed bit for a switched on master control relay if MCR = 1. If MCR = 0, then the value 0 is written to the addressed bit instead of RLO.

Status word

	BR	CC 1	CC 0	OV	OS	OR	STA	RLO	/FC
writes:	-	-	-	-	-	0	x	-	0

Example

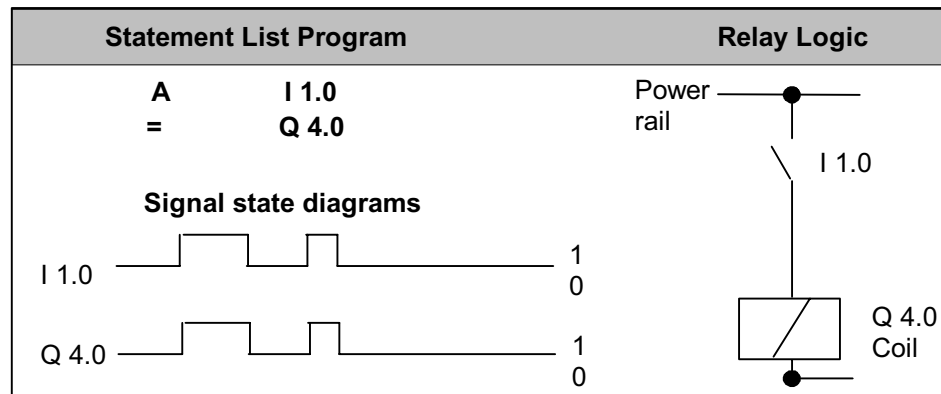

1.17 R Reset

Format

R <Bit>

Address	Data type	Memory area
<Bit>	BOOL	I, Q, M, L, D

Description

R (reset bit) places a "0" in the addressed bit if RLO = 1 and master control relay MCR = 1. If MCR = 0, then the addressed bit will not be changed.

Status word

	BR	CC 1	CC 0	OV	OS	OR	STA	RLO	/FC
writes:	-	-	-	-	-	0	x	-	0

Example

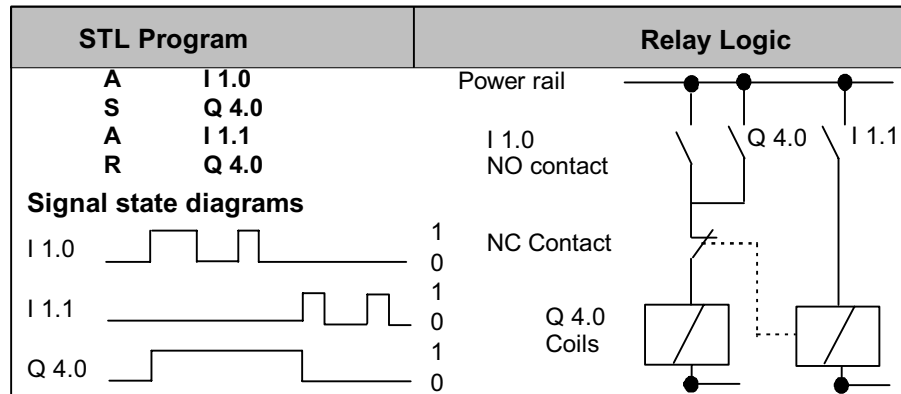

1.18 S Set

Format

S <Bit>

Address	Data type	Memory area
<Bit>	BOOL	I, Q, M, L, D

Description of instruction

S (set bit) places a "1" in the addressed bit if RLO = 1 and the switched on master control relay MCR = 1. If MCR = 0, the addressed bit does not change.

Status word

	BR	CC 1	CC 0	OV	OS	OR	STA	RLO	/FC
writes:	-	-	-	-	-	0	x	-	0

Example

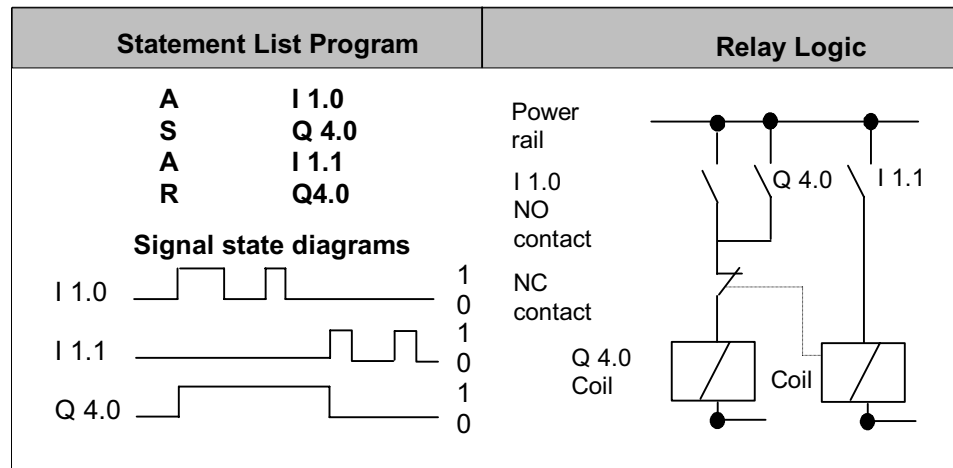

1.19 NOT Negate RLO

Format

NOT

Description

NOT negates the RLO.

Status word

	BR	CC 1	CC 0	OV	OS	OR	STA	RLO	/FC
writes:	-	-	-	-	-	-	1	x	-

1.20 SET Set RLO (=1)

Format

SET

Description

SET sets the RLO to signal state "1".

Status word

	BR	CC 1	CC 0	OV	OS	OR	STA	RLO	/FC
writes:	-	-	-	-	-	0	1	1	0

Example

STL Program	Signal State	Result of Logic Operation (RLO)
SET		1
= M 10.0	1	←
= M 15.1	1	
= M 16.0	1	
CLR		0
= M 10.1	0	←
= M 10.2	0	

1.21 CLR Clear RLO (=0)

Format

CLR

Description

CLR sets the RLO to signal state "0".

Status word

	BR	CC 1	CC 0	OV	OS	OR	STA	RLO	/FC
writes:	-	-	-	-	-	0	0	0	0

Example

Statement List	Signal State	Result of Logic Operation (RLO)
SET		1
= M 10.0	1	←
= M 15.1	1	
= M 16.0	1	
CLR		0
= M 10.1	0	←
= M 10.2	0	

1.22 **SAVE** Save RLO in BR Register

Format

SAVE

Description of instruction

SAVE saves the RLO into the BR bit. The first check bit /FC is not reset. For this reason, the status of the BR bit is included in the AND logic operation in the next network.

The use of **SAVE** and a subsequent query of the BR bit in the same block or in secondary blocks is not recommended because the BR bit can be changed by numerous instructions between the two. It makes sense to use the **SAVE** instruction before exiting a block because this sets the ENO output (= BR bit) to the value of the RLO bit and you can then add error handling of the block to this.

Status word

	BR	CC 1	CC 0	OV	OS	OR	STA	RLO	/FC
writes:	x	-	-	-	-	-	-	-	-

1.23 FN Edge Negative

Format

FN <Bit>

Address	Data type	Memory area	Description
<Bit>	BOOL	I, Q, M, L, D	Edge flag, stores the previous signal state of RLO.

Description

FN <Bit> (Negative RLO edge) detects a falling edge when the RLO transitions from "1" to "0", and indicates this by RLO = 1.

During each program scan cycle, the signal state of the RLO bit is compared with that obtained in the previous cycle to see if there has been a state change. The previous RLO state must be stored in the edge flag address (<Bit>) to make the comparison. If there is a difference between current and previous RLO "1" state (detection of falling edge), the RLO bit will be "1" after this instruction.

Note

The instruction has no point if the bit you want to monitor is in the process image because the local data for a block are only valid during the block's runtime.

Status word

	BR	CC 1	CC 0	OV	OS	OR	STA	RLO	/FC
writes:	-	-	-	-	-	0	x	x	1

Definition

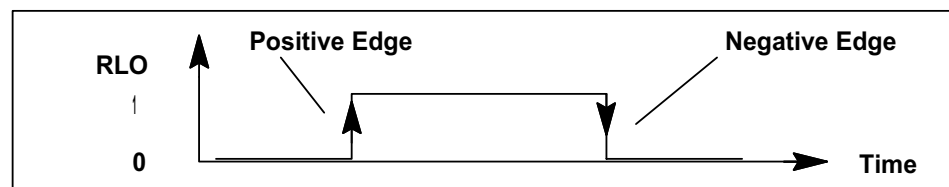

Example

If the programmable logic controller detects a negative edge at contact I 1.0, it energizes the coil at Q 4.0 for one OB1 scan cycle.

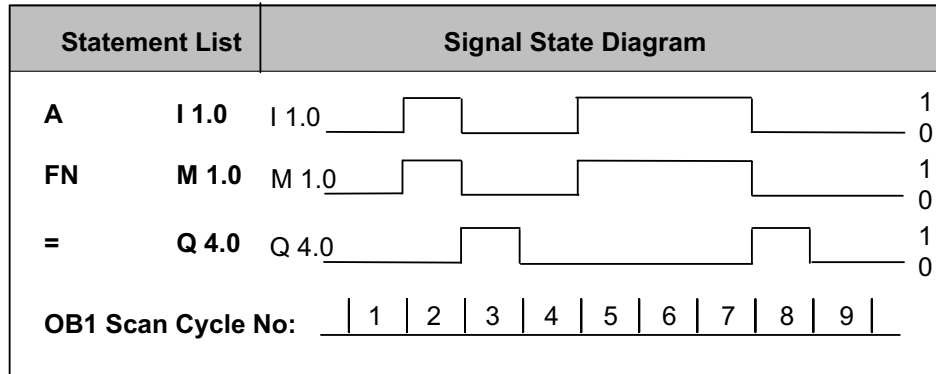

1.24 FP Edge Positive

Format

FP <Bit>

Address	Data type	Memory area	Description
<Bit>	BOOL	I, Q, M, L, D	Edge flag, stores the previous signal state of RLO.

Description

FP <Bit> (Positive RLO edge) detects a rising edge when the RLO transitions from "0" to "1" and indicates this by RLO = 1.

During each program scan cycle, the signal state of the RLO bit is compared with that obtained in the previous cycle to see if there has been a state change. The previous RLO state must be stored in the edge flag address (<Bit>) to make the comparison. If there is a difference between current and previous RLO "0" state (detection of rising edge), the RLO bit will be "1" after this instruction.

Note

The instruction has no point if the bit you want to monitor is in the process image because the local data for a block are only valid during the block's runtime.

Status word

	BR	CC 1	CC 0	OV	OS	OR	STA	RLO	/FC
writes:	-	-	-	-	-	0	x	x	1

Definition

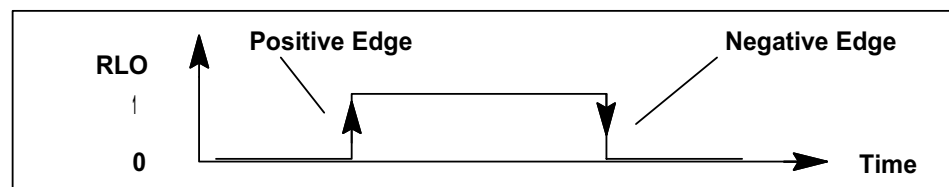

Example

If the programmable logic controller detects a positive edge at contact I 1.0, it energizes the coil at Q 4.0 for one OB1 scan cycle.

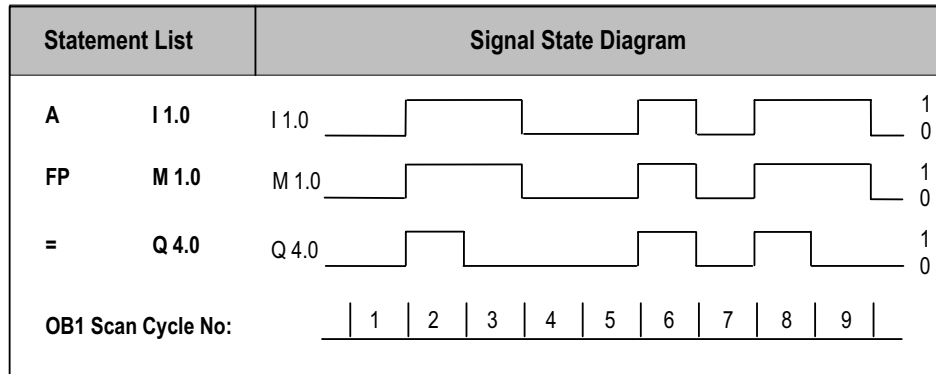

2 Comparison Instructions

2.1 Overview of Comparison Instructions

Description

ACCU1 and ACCU2 are compared according to the type of comparison you choose:

- == ACCU1 is equal to ACCU2
- <> ACCU1 is not equal to ACCU2
- > ACCU1 is greater than ACCU2
- < ACCU1 is less than ACCU2
- >= ACCU1 is greater than or equal to ACCU2
- <= ACCU1 is less than or equal to ACCU2

If the comparison is true, the RLO of the function is "1". The status word bits CC 1 and CC 0 indicate the relations "less," "equal," or "greater."

There are comparison instructions to perform the following functions:

- ? I Compare Integer (16-Bit)
- ? D Compare Double Integer (32-Bit)
- ? R Compare Floating-Point Number (32-Bit)

2.2 ? I Compare Integer (16-Bit)

Format

==I, <>I, >I, <I, >=I, <=I

Description of instruction

The Compare Integer (16-bit) instructions compare the contents of ACCU 2-L with the contents of ACCU 1-L. The contents of ACCU 2-L and ACCU 1-L are interpreted as 16-bit integer numbers. The result of the comparison is indicated by the RLO and the setting of the relevant status word bits. RLO = 1 indicates that the result of the comparison is true; RLO = 0 indicates that the result of the comparison is false. The status word bits CC 1 and CC 0 indicate the relations "less," "equal," or "greater."

Status word

	BR	CC 1	CC 0	OV	OS	OR	STA	RLO	/FC
writes:	-	x	x	0	-	0	x	x	1

RLO values

Comparison instruction executed	RLO Result if ACCU 2 > ACCU 1	RLO Result if ACCU 2 = ACCU 1	RLO Result if ACCU 2 < ACCU 1
==I	0	1	0
<>I	1	0	1
>I	1	0	0
<I	0	0	1
>=I	1	1	0
<=I	0	1	1

Example

STL	Explanation
L MW10	//Load contents of MW10 (16-bit integer).
L IW24	//Load contents of IW24 (16-bit integer).
>I	//Compare if ACCU 2-L (MW10) is greater (>) than ACCU 1- L (IW24).
= M 2.0	//RLO = 1 if MW10 > IW24.

2.3 ? D Compare Double Integer (32-Bit)

Format

==D, <>D, >D, <D, >=D, <=D

Description of instruction

The Compare Double Integer (32-bit) instructions compare the contents of ACCU 2 with the contents of ACCU 1. The contents of ACCU 2 and ACCU 1 are interpreted as 32-bit integer numbers. The result of the comparison is indicated by the RLO and the setting of the relevant status word bits. RLO = 1 indicates that the result of the comparison is true; RLO = 0 indicates that the result of the comparison is false. The status word bits CC 1 and CC 0 indicate the relations "less," "equal," or "greater."

Status word

	BR	CC 1	CC 0	OV	OS	OR	STA	RLO	/FC
writes:	-	x	x	0	-	0	x	x	1

RLO values

Comparison instruction executed	RLO Result if ACCU 2 > ACCU 1	RLO Result if ACCU 2 = ACCU 1	RLO Result if ACCU 2 < ACCU 1
==D	0	1	0
<>D	1	0	1
>D	1	0	0
<D	0	0	1
>=D	1	1	0
<=D	0	1	1

Example

STL	Explanation
L MD10	//Load contents of MD10 (double integer, 32 bits).
L ID24	//Load contents of ID24 (double integer, 32 bits).
>D	//Compare if ACCU 2 (MD10) is greater (>) than ACCU 1 (ID24).
= M 2.0	//RLO = 1 if MD10 > ID24

2.4 ? R Compare Floating-Point Number (32-Bit)

Format

==R, <>R, >R, <R, >=R, <=R

Description of instruction

The Compare Floating Point Number (32-bit, IEEE-FP) instructions compare the contents of ACCU 2 with the contents of ACCU 1. The contents of ACCU 1 and ACCU 2 are interpreted as floating-point numbers (32-bit, IEEE-FP). The result of the comparison is indicated by the RLO and the setting of the relevant status word bits. RLO = 1 indicates that the result of the comparison is true; RLO = 0 indicates that the result of the comparison is false. The status word bits CC 1 and CC 0 indicate the relations "less," "equal," or "greater."

Status word

	BR	CC 1	CC 0	OV	OS	OR	STA	RLO	/FC
writes:	-	x	x	x	x	0	x	x	1

RLO values

Comparison instruction executed	RLO Result if ACCU 2 > ACCU 1	RLO Result if ACCU 2 = ACCU 1	RLO Result if ACCU 2 < ACCU 1
==R	0	1	0
<>R	1	0	1
>R	1	0	0
<R	0	0	1
>=R	1	1	0
<=R	0	1	1

Example

STL	Explanation
L MD10	//Load contents of MD10 (floating-point number).
L 1.359E+02	//Load the constant 1.359E+02.
>R	//Compare if ACCU 2 (MD10) is greater (>) than ACCU 1 (1.359-E+02).
= M 2.0	//RLO = 1 if MD10 > 1.359E+02.

3 Conversion Instructions

3.1 Overview of Conversion Instructions

Description

You can use the following instructions to convert binary coded decimal numbers and integers to other types of numbers:

- BTI BCD to Integer (16-Bit)
- ITB Integer (16-Bit) to BCD
- BTD BCD to Integer (32-Bit)
- ITD Integer (16-Bit) to Double Integer (32-Bit)
- DTB Double Integer (32-Bit) to BCD
- DTR Double Integer (32-Bit) to Floating-Point (32-Bit IEEE-FP)

You can use one of the following instructions to form the complement of an integer or to invert the sign of a floating-point number:

- INVI Ones Complement Integer (16-Bit)
- INVD Ones Complement Double Integer (32-Bit)
- NEGI Twos Complement Integer (16-Bit)
- NEGD Twos Complement Double Integer (32-Bit)
- NEGR Negate Floating-Point Number (32-Bit, IEEE-FP)

You can use the following Change Bit Sequence in Accumulator 1 instructions to reverse the order of bytes in the low word of accumulator 1 or in the entire accumulator:

- CAW Change Byte Sequence in ACCU 1-L (16-Bit)
- CAD Change Byte Sequence in ACCU 1 (32-Bit)

You can use any of the following instructions to convert a 32-bit IEEE floating-point number in accumulator 1 to a 32-bit integer (double integer). The individual instructions differ in their method of rounding:

- RND Round
- TRUNC Truncate
- RND+ Round to Upper Double Integer
- RND- Round to Lower Double Integer

3.2 BTI BCD to Integer (16-Bit)

Format

BTI

Description

BTI (decimal to binary conversion of a 3-digit BCD number) interprets the contents of ACCU 1-L as a three-digit binary coded decimal number (BCD) and converts it to a 16-bit integer. The result is stored in the low word of accumulator 1. The high word of accumulator 1 and accumulator 2 remain unchanged.

BCD number in ACCU 1-L: The permissible value range for the BCD number is from "-999" to "+999". Bit 0 to bit 11 are interpreted as the value and bit 15 as the sign (0 = positive, 1= negative) of the BCD number. Bit 12 to bit 14 are not used in the conversion. If a decimal (4 bits) of the BCD number is in the invalid range of 10 to 15, a BCDF error occurs during attempted conversion. In general, the CPU will go into STOP. However, you may design another error response by programming OB121 to handle this synchronous programming error.

Status word

	BR	CC 1	CC 0	OV	OS	OR	STA	RLO	/FC
writes:	-	-	-	-	-	-	-	-	-

Example

STL	Explanation
L MW10	//Load the BCD number into ACCU 1-L.
BTI	//Convert from BCD to integer; store result in ACCU 1-L.
T MW20	//Transfer result (integer number) to MW20.

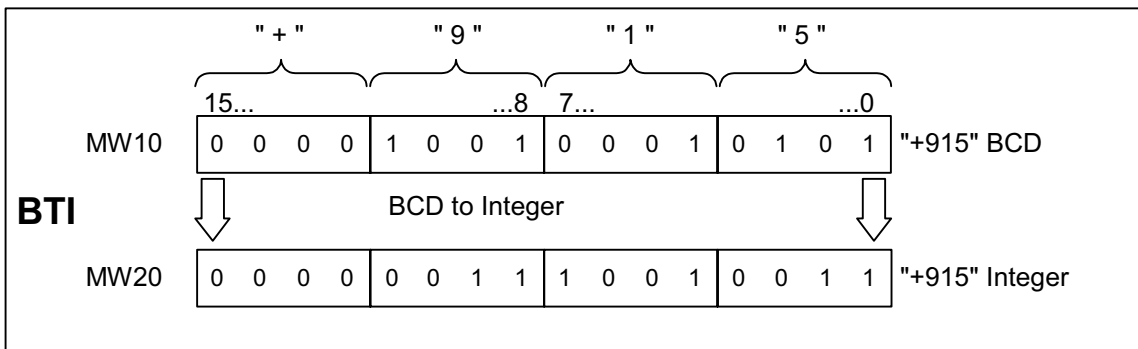

3.3 ITB Integer (16-Bit) to BCD

Format

ITB

Description

ITB (binary to decimal conversion of a 16-bit integer number) interprets the contents of ACCU 1-L as a 16-bit integer and converts it to a three-digit binary coded decimal number (BCD). The result is stored in the low word of accumulator 1. Bit 0 to bit 11 contain the value of the BCD number. Bit 12 to bit 15 are set to the state of the sign (0000 = positive, 1111= negative) of the BCD number. The high word of accumulator 1 and accumulator 2 remain unchanged.

The BCD number can be in the range of "-999" to "+999." If the number is out of the permissible range, then the status bits OV and OS are set to 1.

The instruction is executed without regard to, and without affecting, the RLO.

Status word

	BR	CC 1	CC 0	OV	OS	OR	STA	RLO	/FC
writes:	-	-	-	x	x	-	-	-	-

Example

STL	Explanation
L MW10	//Load the integer number into ACCU 1-L.
ITB	//Convert from integer to BCD (16-bit); store result in ACCU 1-L.
T MW20	//Transfer result (BCD number) to MW20.

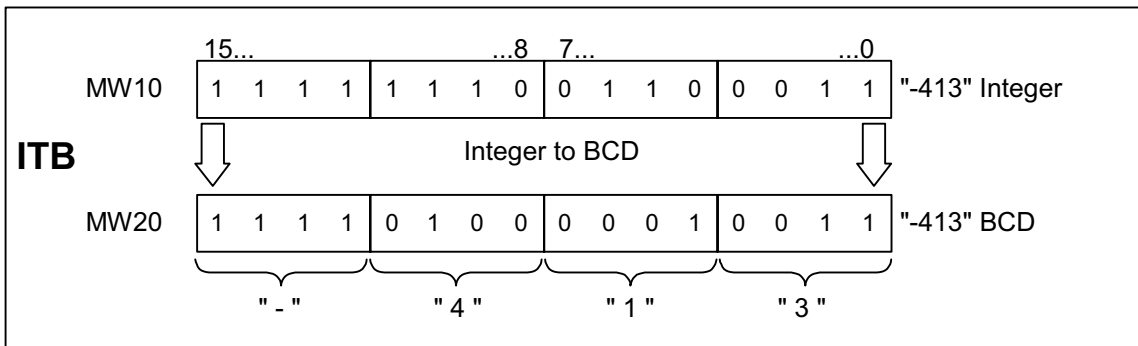

3.4 BT D BCD to Integer (32-Bit)

Format

BT D

Description

BT D (decimal to binary conversion of a 7-digit BCD number) interprets the contents of ACCU 1 as a seven digit binary coded decimal number (BCD) and converts it to a 32-bit double integer. The result is stored in accumulator 1. Accumulator 2 remains unchanged.

BCD number in ACCU 1: The permissible value range for the BCD number is from "-9,999,999" to "+9,999,999". Bit 0 to bit 27 are interpreted as the value and bit 31 as the sign (0 = positive, 1= negative) of the BCD number. Bit 28 to bit 30 are not used in the conversion.

If any decimal digit (a 4-bit tetrad of the BCD coding) is in the invalid range of 10 to 15, a BCDF error occurs during attempted conversion. In general, the CPU will go into STOP. However, you may design another error response by programming OB121 to handle this synchronous programming error.

Status word

	BR	CC 1	CC 0	OV	OS	OR	STA	RLO	/FC
writes:	-	-	-	-	-	-	-	-	-

Example

STL	Explanation
L MD10	//Load the BCD number into ACCU 1.
BT D	//Convert from BCD to integer; store result in ACCU 1.
T MD20	//Transfer result (double integer number) to MD20.

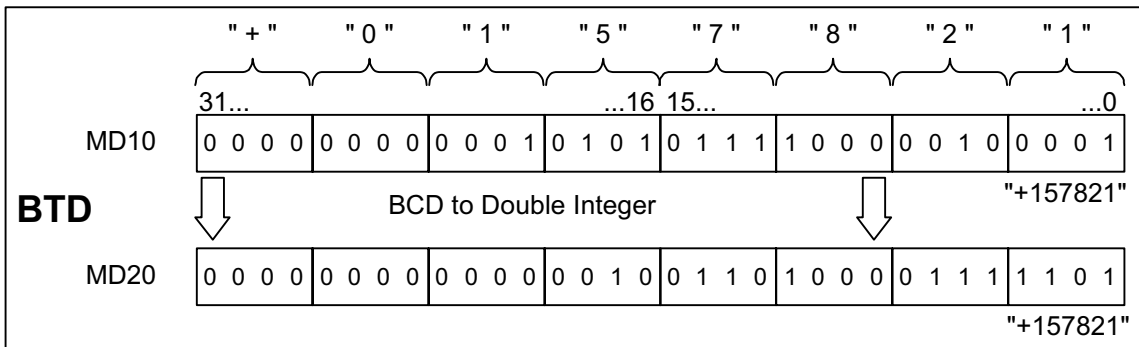

3.5 ITD Integer (16 Bit) to Double Integer (32-Bit)

Format

ITD

Description

ITD (conversion of a 16-bit integer number to a 32-bit integer number) interprets the contents of ACCU 1-L as a 16-bit integer and converts it to a 32-bit double integer. The result is stored in accumulator 1. Accumulator 2 remains unchanged.

Status word

	BR	CC 1	CC 0	OV	OS	OR	STA	RLO	/FC
writes:	-	-	-	-	-	-	-	-	-

Example

STL	Explanation
L MW12	//Load the integer number into ACCU 1.
ITD	//Convert from integer (16-bit) to double integer (32-bit); store result in ACCU 1.
T MD20	//Transfer result (double integer) to MD20.

Example: MW12 = "-10" (Integer, 16-bit)

Contents	ACCU1-H				ACCU1-L			
Bit	31...16	15...0
before execution of ITD	XXXX	XXX X	XXX X	XXX X	1111	1111	1111	0110
after execution of ITD	1111	1111	1111	1111	1111	1111	1111	0110
	(X = 0 or 1, bits are not used for conversion)							

3.6 DTB Double Integer (32-Bit) to BCD

Format

DTB

Description

DTB (binary to decimal conversion of a 32-bit integer number) interprets the content of ACCU 1 as a 32-bit double integer and converts it to a seven-digit binary coded decimal number (BCD). The result is stored in accumulator 1. Bit 0 to bit 27 contain the value of the BCD number. Bit 28 to bit 31 are set to the state of the sign of the BCD number (0000 = positive, 1111 = negative). Accumulator 2 remains unchanged.

The BCD number can be in the range of "-9,999,999" to "+9,999,999". If the number is out of the permissible range, then the status bits OV and OS are set to 1.

Status word

	BR	CC 1	CC 0	OV	OS	OR	STA	RLO	/FC
writes:	-	-	-	x	x	-	-	-	-

Example

STL	Explanation
L MD10	//Load the 32-bit integer into ACCU 1.
DTB	//Convert from integer (32-bit) to BCD, store result in ACCU 1.
T MD20	//Transfer result (BCD number) to MD20.

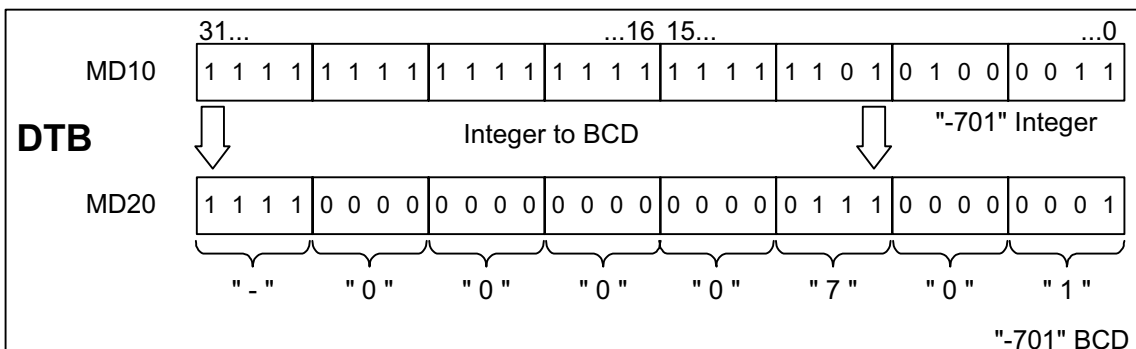

3.7 DTR Double Integer (32-Bit) to Floating-Point (32-Bit IEEE-FP)

Format

DTR

Description

DTR (conversion of a 32-bit integer number to a 32-bit IEEE floating point number) interprets the content of ACCU 1 as a 32-bit double integer and converts it to a 32-bit IEEE floating point number. If necessary, the instruction rounds the result. (A 32-bit integer has a higher accuracy than a 32-bit floating point number). The result is stored in accumulator 1.

Status word

	BR	CC 1	CC 0	OV	OS	OR	STA	RLO	/FC
writes:	-	-	-	-	-	-	-	-	-

Example

STL	Explanation
L MD10	//Load the 32-bit integer into ACCU 1.
DTR	//Convert from double integer to floating point (32-bit IEEE FP); store result in ACCU 1.
T MD20	//Transfer result (BCD number) to MD20.

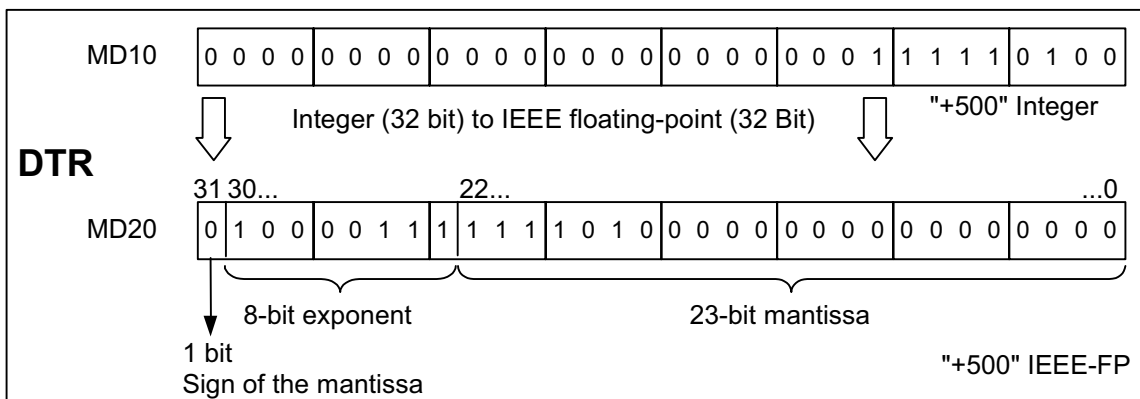

3.8 INVI Ones Complement Integer (16-Bit)

Format

INVI

Description

INVI (ones complement integer) forms the ones complement of the 16-bit value in ACCU 1-L. Forming the ones complement inverts the value bit by bit, that is, zeros replace ones and ones replace zeros. The result is stored in the low word of accumulator 1.

Status word

	BR	CC 1	CC 0	OV	OS	OR	STA	RLO	/FC
writes:	-	-	-	-	-	-	-	-	-

Example

STL	Explanation
L IW8	//Load value into ACCU 1-L.
INVI	//Form ones complement 16-bit.
T MW10	//Transfer result to MW10.

Contents	ACCU1-L			
Bit	15 0
before execution of INVI	0110	0011	1010	1110
after execution of INVI	1001	1100	0101	0001

3.9 INVD Ones Complement Double Integer (32-Bit)

Format

INVD

Description

INVD (ones complement double integer) forms the ones complement of the 32-bit value in ACCU 1. Forming the ones complement inverts the value bit by bit, that is, zeros replace ones, and ones replace zeros. The result is stored in accumulator 1.

Status word

	BR	CC 1	CC 0	OV	OS	OR	STA	RLO	/FC
writes:	-	-	-	-	-	-	-	-	-

Example

STL	Explanation
L ID8	//Load value into ACCU 1.
INVD	//Form ones complement (32-bit).
T MD10	//Transfer result to MD10.

Contents	ACCU1-H				ACCU1-L			
Bit	31 16	150
before execution of INVD	0110	1111	1000	1100	0110	0011	1010	1110
after execution of INVD	1001	0000	0111	0011	1001	1100	0101	0001

3.10 NEGI Twos Complement Integer (16-Bit)

Format

NEGI

Description

NEGI (twos complement integer) forms the twos complement of the 16-bit value in ACCU 1-L. Forming the twos complement inverts the value bit by bit, that is, zeros replace ones and ones replace zeros; then a "1" is added. The result is stored in the low word of accumulator 1. The twos complement instruction is equivalent to multiplication by "-1." The status bits CC 1, CC 0, OS, and OV are set as a function of the result of the operation.

Status word

	BR	CC 1	CC 0	OV	OS	OR	STA	RLO	/FC
writes:	-	x	x	x	x	-	-	-	-

Status word generation	CC 1	CC 0	OV	OS
Result = 0	0	0	0	-
-32768 <= Result <= -1	0	1	0	-
32767 >= Result >= 1	1	0	0	-
Result = 2768	0	1	1	1

Example

STL	Explanation
L IW8	//Load value into ACCU 1-L.
NEGI	//Form twos complement 16-bit.
T MW10	//Transfer result to MW10.

Contents	ACCU1-L			
Bit	15 0
before execution of NEGI	0101	1101	0011	1000
after execution of NEGI	1010	0010	1100	1000

3.11 NEGD Twos Complement Double Integer (32-Bit)

Format

NEGD

Description

NEGD (twos complement double integer) forms the twos complement of the 32-bit value in ACCU 1. Forming the twos complement inverts the value bit by bit, that is, zeros replace ones and ones replace zeros; then a "1" is added. The result is stored in accumulator 1. The twos complement instruction is equivalent to a multiplication by "-1". The instruction is executed without regard to, and without affecting, the RLO. The status bits CC 1, CC 0, OS, and OV are set as a function of the result of the operation.

Status word

	BR	CC 1	CC 0	OV	OS	OR	STA	RLO	/FC
writes:	-	x	x	x	x	-	-	-	-

Status word generation	CC 1	CC 0	OV	OS
Result = 0	0	0	0	-
-2.147.483.648 <= Result <= -1	0	1	0	-
2.147.483.647 >= Result >= 1	1	0	0	-
Result = 2 147 483 648	0	1	1	1

Example

STL	Explanation
L ID8	//Load value into ACCU 1.
NEGD	//Generate twos complement (32-bit).
T MD10	//Transfer result to MD10.

Contents	ACCU1-H				ACCU1-L			
Bit	31 16	15 0
before execution of NEGD	0101	1111	0110	0100	0101	1101	0011	1000
after execution of NEGD	1010	0000	1001	1011	1010	0010	1100	1000

3.12 NEGR Negate Floating-Point Number (32-Bit, IEEE-FP)

Format

NEGR

Description of instruction

NEGR (negate 32-bit IEEE floating-point number) negates the floating-point number (32-bit, IEEE-FP) in ACCU 1. The instruction inverts the state of bit 31 in ACCU 1 (sign of the mantissa). The result is stored in accumulator 1.

Status word

	BR	CC 1	CC 0	OV	OS	OR	STA	RLO	/FC
writes:	-	-	-	-	-	-	-	-	-

Example

STL	Explanation
L ID8	//Load value into ACCU 1 (example: ID 8 = 1.5E+02).
NEGR	//Negate floating-point number (32-bit, IEEE-FP); stores the result in ACCU 1.
T MD10	//Transfer result to MD10 (example: result = -1.5E+02).

3.13 CAW Change Byte Sequence in ACCU 1-L (16-Bit)

Format

CAW

Description

CAW reverses the sequence of bytes in ACCU 1-L. The result is stored in the low word of accumulator 1. The high word of accumulator 1 and accumulator 2 remain unchanged.

Status word

	BR	CC 1	CC 0	OV	OS	OR	STA	RLO	/FC
writes:	-	-	-	-	-	-	-	-	-

Example

STL	Explanation
L MW10	//Load the value of MW10 into ACCU 1.
CAW	//Reverse the sequence of bytes in ACCU 1-L.
T MW20	//Transfer the result to MW20.

Contents	ACCU1-H-H	ACCU1-H-L	ACCU1-L-H	ACCU1-L-L
before execution of CAW	value A	value B	value C	value D
after execution of CAW	value A	value B	value D	value C

3.14 CAD Change Byte Sequence in ACCU 1 (32-Bit)

Format

CAD

Description

CAD reverses the sequence of bytes in ACCU 1. The result is stored in accumulator 1. Accumulator 2 remains unchanged.

Status word

	BR	CC 1	CC 0	OV	OS	OR	STA	RLO	/FC
writes:	-	-	-	-	-	-	-	-	-

Example

STL	Explanation
L MD10	//Load the value of MD10 into ACCU 1.
CAD	//Reverse the sequence of bytes in ACCU 1.
T MD20	//Transfer the results to MD20.

Contents	ACCU1-H-H	ACCU1-H-L	ACCU1-L-H	ACCU1-L-L
before execution of CAD	value A	value B	value C	value D
after execution of CAD	value D	value C	value B	value A

3.15 RND Round

Format

RND

Description

RND (conversion of a 32-bit IEEE floating-point number to 32-bit integer) interprets the contents of ACCU 1 as a 32-bit IEEE floating-point number (32-bit, IEEE-FP). The instruction converts the 32-bit IEEE floating-point number to a 32-bit integer (double integer) and rounds the result to the nearest whole number. If the fractional part of the converted number is midway between an even and an odd result, the instruction chooses the even result. If the number is out of the permissible range, then the status bits OV and OS are set to 1. The result is stored in accumulator 1.

Conversion is not performed and an overflow indicated in the event of a fault (utilization of a NaN or a floating-point number that cannot be represented as a 32-bit integer number).

Status word

	BR	CC 1	CC 0	OV	OS	OR	STA	RLO	/FC
writes:	-	-	-	x	x	-	-	-	-

Example

STL	Explanation
L MD10	//Load the floating-point number into ACCU 1-L.
RND	//Convert the floating-point number (32-bit, IEEE-FP) into an integer (32-bit) and round off the result.
T MD20	//Transfer result (double integer number) to MD20.

Value before conversion		Value after conversion
MD10 = "100.5"	=> RND =>	MD20 = "+100"
MD10 = "-100.5"	=> RND =>	MD20 = "-100"

3.16 TRUNC Truncate

Format

TRUNC

Description

TRUNC (conversion of a 32-bit IEEE floating-point number to 32-bit integer) interprets the contents of ACCU 1 as a 32-bit IEEE floating-point number. The instruction converts the 32-bit IEEE floating-point number to a 32-bit integer (double integer). The result is the whole number part of the floating-point number to be converted (IEEE rounding mode "round to zero"). If the number is out of the permissible range, then the status bits OV and OS are set to 1. The result is stored in accumulator 1.

Conversion is not performed and an overflow indicated in the event of a fault (utilization of a NaN or a floating-point number that cannot be represented as a 32-bit integer number).

Status word

	BR	CC 1	CC 0	OV	OS	OR	STA	RLO	/FC
writes:	-	-	-	x	x	-	-	-	-

Example

STL	Explanation
L MD10	//Load the floating-point number into ACCU 1-L.
TRUNC	//Convert the floating-point number (32-bit, IEEE-FP) to an integer (32-bit) and round result. Store the result in ACCU 1.
T MD20	//Transfer result (double integer number) to MD20.

Value before conversion		Value after conversion
MD10 = "100.5"	=> TRUNC =>	MD20 = "+100"
MD10 = "-100.5"	=> TRUNC =>	MD20 = "-100"

3.17 RND+ Round to Upper Double Integer

Format

RND+

Description

RND+ (conversion of a 32-bit IEEE floating-point number to 32-bit integer) interprets the contents of ACCU 1 as a 32-bit IEEE floating-point number. The instruction converts the 32-bit IEEE floating-point number to a 32-bit integer (double integer) and rounds the result to the smallest whole number greater than or equal to the floating-point number that is converted (IEEE rounding mode "round to +infinity"). If the number is out of the permissible range, then the status bits OV and OS are set to 1. The result is stored in accumulator 1.

Conversion is not performed and an overflow is indicated in the event of a fault (utilization of a NaN or a floating-point number that cannot be represented as a 32-bit integer number.)

Status word

	BR	CC 1	CC 0	OV	OS	OR	STA	RLO	/FC
writes:	-	-	-	x	x	-	-	-	-

Example

STL	Explanation
L MD10	//Load the floating-point number (32-bit, IEEE-FP) into ACCU 1-L.
RND+	//Convert the floating-point number (32-bit, IEEE-FP) to an integer (32-bit) and round result. Store output in ACCU 1.
T MD20	//Transfer result (double integer number) to MD20.

Value before conversion		Value after conversion
MD10 = "100.5"	=> RND+ =>	MD20 = "+100"
MD10 = "-100.5"	=> RND+ =>	MD20 = "-100"

3.18 RND- Round to Lower Double Integer

Format

RND-

Description

RND- (conversion of a 32-bit IEEE floating-point number to 32-bit integer) interprets the contents of ACCU 1 as 32-bit IEEE floating-point number. The instruction converts the 32-bit IEEE floating-point number to a 32-bit integer (double integer) and rounds the result to the largest whole number less than or equal to the floating-point number that is converted (IEEE rounding mode "round to -infinity"). If the number is out of the permissible range, then the status bits OV and OS are set to 1. The result is stored in accumulator 1.

Conversion is not performed and an overflow indicated in the event of a fault (utilization of a NaN or a floating-point number that cannot be represented as a 32-bit integer number.)

Status word

	BR	CC 1	CC 0	OV	OS	OR	STA	RLO	/FC
writes:	-	-	-	x	x	-	-	-	-

Example

STL	Explanation
L MD10	//Load the floating-point number into ACCU 1-L.
RND-	//Convert the floating-point number (32-bit, IEEE-FP) to an integer (32-bit) and round result. Store result in ACCU 1.
T MD20	//Transfer result (double integer number) to MD20.

Value before conversion		Value after conversion
MD10 = "100.5"	=> RND- =>	MD20 = "+100"
MD10 = "-100.5"	=> RND- =>	MD20 = "-100"

4 Counter Instructions

4.1 Overview of Counter Instructions

Description

A counter is a function element of the STEP 7 programming language that counts. Counters have an area reserved for them in the memory of your CPU. This memory area reserves one 16-bit word for each counter. The statement list instruction set supports 256 counters. To find out how many counters are available in your CPU, please refer to the CPU technical data.

Counter instructions are the only functions with access to the memory area.

You can vary the count value within this range by using the following Counter instructions:

- FR Enable Counter (Free)
- L Load Current Counter Value into ACCU 1
- LC Load Current Counter Value into ACCU 1 as BCD
- R Reset Counter
- S Set Counter Preset Value
- CU Counter Up
- CD Counter Down

4.2 FR Enable Counter (Free)

Format

FR <counter>

Address	Data type	Memory area	Description
<counter>	COUNTER	C	Counter, range depends on CPU.

Description

When RLO transitions from "0" to "1", FR <counter> clears the edge-detecting flag that is used for setting and selecting upwards or downwards count of the addressed counter. Enable counter is not required to set a counter or for normal counting. This means that in spite of a constant RLO of 1 for the Set Counter Preset Value, Counter Up, or Counter Down, these instructions are not executed again after the enable.

Status word

	BR	CC 1	CC 0	OV	OS	OR	STA	RLO	/FC
writes:	-	-	-	-	-	0	-	-	0

Example

STL	Explanation
A I 2.0	//Check signal state at input I 2.0.
FR C3	//Enable counter C3 when RLO transitions from 0 to 1.

4.3 L Load Current Counter Value into ACCU 1

Format

L <counter>

Address	Data type	Memory area	Description
<counter>	COUNTER	C	Counter, range depends on CPU.

Description

L <counter> loads the current count of the addressed counter as an integer into ACCU 1-L after the contents of ACCU 1 have been saved into ACCU 2.

Status word

	BR	CC 1	CC 0	OV	OS	OR	STA	RLO	/FC
writes:	-	-	-	-	-	-	-	-	-

Example

STL	Explanation
L C3	//Load ACCU 1-L with the count value of counter C3 in binary format.

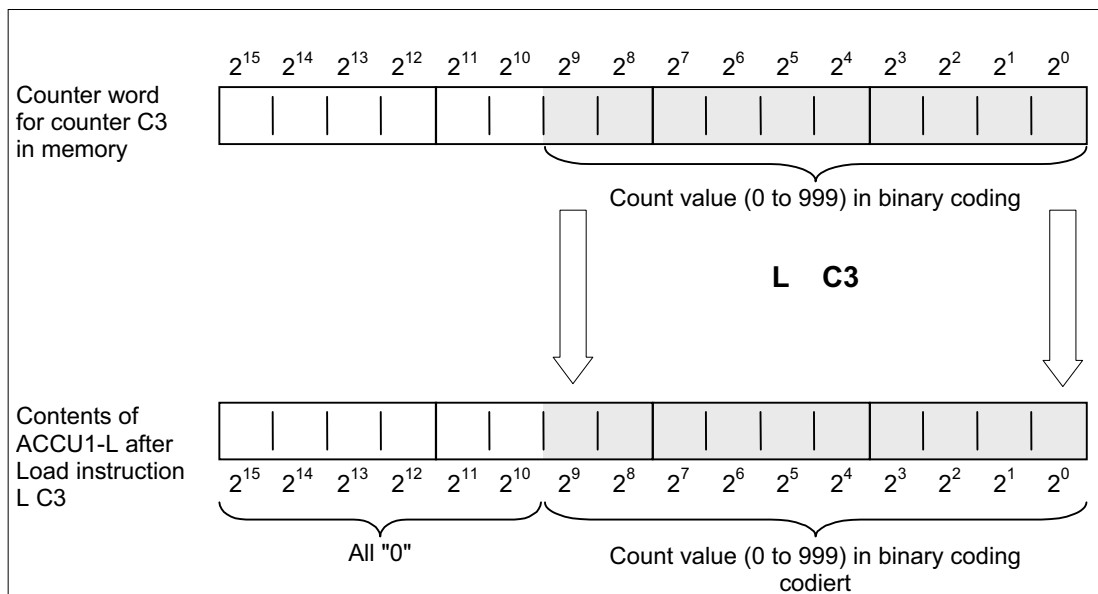

4.4 LC Load Current Counter Value into ACCU 1 as BCD

Format

LC <counter>

Address	Data type	Memory area	Description
<counter>	COUNTER	C	Counter, range depends on CPU.

Description

LC <counter> loads the count of the addressed counter as a BCD number into ACCU 1 after the old contents of ACCU 1 have been saved into ACCU 2.

Status word

	BR	CC 1	CC 0	OV	OS	OR	STA	RLO	/FC
writes:	-	-	-	-	-	-	-	-	-

Example

STL	Explanation
LC C3	//Load ACCU 1-L with the count value of counter C3 in binary coded decimal format.

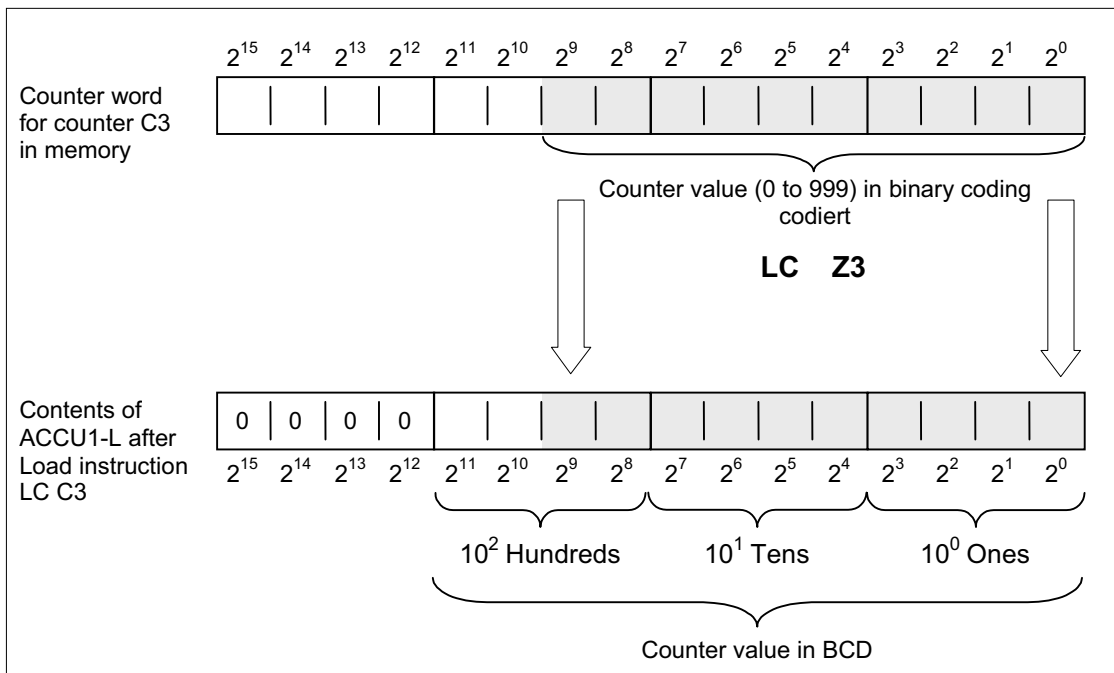

4.5 R Reset Counter

Format

R <counter>

Address	Data type	Memory area	Description
<Counter>	COUNTER	C	Counter to be preset, range depends on CPU.

Description

R <counter> loads the addressed counter with "0" if RLO=1.

Status word

	BR	CC 1	CC 0	OV	OS	OR	STA	RLO	/FC
writes:	-	-	-	-	-	0	-	-	0

Example

STL	Explanation
A I 2.3	//Check signal state at input I 2.3.
R C3	//Reset counter C3 to a value of 0 if RLO transitions from 0 to 1.

4.6 S Set Counter Preset Value

Format

S <counter>

Address	Data type	Memory area	Description
<Counter>	COUNTER	C	Counter to be preset, range depends on CPU.

Description

S <counter> loads the count from ACCU 1-L into the addressed counter when the RLO transitions from "0" to "1". The count in ACCU 1 must be a BCD number between "0" and "999".

Status word

	BR	CC 1	CC 0	OV	OS	OR	STA	RLO	/FC
writes:	-	-	-	-	-	0	-	-	0

Example

STL	Explanation
A I 2.3	//Check signal state at input I 2.3.
L C#3	//Load count value 3 into ACCU 1-L.
S C1	//Set counter C1 to count value if RLO transitions from 0 to 1.

4.7 CU Counter Up

Format

CU <counter>

Address	Data type	Memory area	Description
<counter>	COUNTER	C	Counter, range depends on CPU.

Description

CU <counter> increments the count of the addressed counter by 1 when RLO transitions from "0" to "1" and the count is less than "999". When the count reaches its upper limit of "999", incrementing stops. Additional transitions of RLO have no effect and overflow OV bit is not set.

Status word

	BR	CC 1	CC 0	OV	OS	OR	STA	RLO	/FC
writes:	-	-	-	-	-	0	-	-	0

Example

STL	Explanation
A I 2.1	//If there is a positive edge change at input I 2.1.
CU C3	//Counter C3 is incremented by 1 when RLO transitions from 0 to 1.

4.8 CD Counter Down

Format

CD <counter>

Address	Data type	Memory area	Description
<counter>	COUNTER	C	Counter, range depends on CPU.

Description

CD <counter> decrements the count of the addressed counter by 1 when RLO transitions from "0" to "1" and the count is greater than 0. When the count reaches its lower limit of "0", decrementing stops. Additional transitions of RLO have no effect as the counter will not count with negative values.

Status word

	BR	CC 1	CC 0	OV	OS	OR	STA	RLO	/FC
writes:	-	-	-	-	-	0	-	-	0

Example

STL	Explanation
L C#14	//Counter preset value.
A I 0.1	//Preset counter after detection of rising edge of I 0.1.
S C1	//Load counter 1 preset if enabled.
A I 0.0	//One count down per rising edge of I 0.0.
CD C1	//Decrement counter C1 by 1 when RLO transitions from 0 to 1 depending on input I 0.0.
AN C1	//Zero detection using the C1 bit.
= Q 0.0	//Q 0.0 = 1 if counter 1 value is zero.

5 Data Block Instructions

5.1 Overview of Data Block Instructions

Description

You can use the Open a Data Block (OPN) instruction to open a data block as a shared data block or as an instance data block. The program itself can accommodate one open shared data block and one open instance data block at the same time.

The following Data Block instructions are available:

- OPN Open a Data Block
- CDB Exchange Shared DB and Instance DB
- L DBLG Load Length of Shared DB in ACCU 1
- L DBNO Load Number of Shared DB in ACCU 1
- L DILG Load Length of Instance DB in ACCU 1
- L DINO Load Number of Instance DB in ACCU 1

5.2 OPN Open a Data Block

Format

OPN <data block>

Address	Data block type	Source address
<data block>	DB, DI	1 to 65535

Description of instruction

OPN <data block> opens a data block as a shared data block or as an instance data block. One shared data block and one instance data block can be open at the same time.

Status word

	BR	CC 1	CC 0	OV	OS	OR	STA	RLO	/FC
writes:	-	-	-	-	-	-	-	-	-

Example

STL	Explanation
OPN DB10	//Open data block DB10 as a shared data block.
L DBW35	//Load data word 35 of the opened data block into ACCU 1-L.
T MW22	//Transfer the content of ACCU 1-L into MW22.
OPN DI20	//Open data block DB20 as an instance data block.
L DIB12	//Load data byte 12 of the opened instance data block into ACCU 1-L.
T DBB37	//Transfer the content of ACCU 1-L to data byte 37 of the opened shared data block.

5.3 CDB Exchange Shared DB and Instance DB

Format

CDB

Description of instruction

CDB is used to exchange the shared data block and instance data block. The instruction swaps the data block registers. A shared data block becomes an instance data block and vice-versa.

Status word

	BR	CC 1	CC 0	OV	OS	OR	STA	RLO	/FC
writes:	-	-	-	-	-	-	-	-	-

5.4 L DBLG Load Length of Shared DB in ACCU 1

Format

L DBLG

Description of instruction

L DBLG (load length of shared data block) loads the length of the shared data block into ACCU 1 after the contents of ACCU 1 have been saved into ACCU 2.

Status word

	BR	CC 1	CC 0	OV	OS	OR	STA	RLO	/FC
writes:	-	-	-	-	-	-	-	-	-

Example

STL	Explanation	
OPN DB10	//Open data block DB10 as shared data block.	
L DBLG	//Load length of shared data block (length of DB10).	
L MD10	//Value for comparison if data block is long enough.	
<D		
JC ERRO	//Jump to ERRO jump label if length is less than value in MD10.	

5.5 L DBNO Load Number of Shared DB in ACCU 1

Format

L DBNO

Description of instruction

L DBNO (load number of shared data block) loads the number of the shared open data block into ACCU 1-L after the content of ACCU 1 has been saved into ACCU 2.

Status word

	BR	CC 1	CC 0	OV	OS	OR	STA	RLO	/FC
writes:	-	-	-	-	-	-	-	-	-

5.6 L DILG Load Length of Instance DB in ACCU 1

Format

L DILG

Description of instruction

L DILG (load length of instance data block) loads the length of the instance data block into ACCU 1-L after the content of ACCU 1 has been saved into ACCU 2.

Status word

	BR	CC 1	CC 0	OV	OS	OR	STA	RLO	/FC
writes:	-	-	-	-	-	-	-	-	-

Example

STL	Explanation
OPN D120	//Open data block DB20 as an instance data block.
L DILG	//Load length of instance data block (length of DB20).
L MW10	//Value for comparison if data block is long enough.
<1	
JC	//Jump to ERRO jump label if length is less than value in MW10.

5.7 L DINO Load Number of Instance DB in ACCU 1

Format

L DINO

Description of instruction

L DINO (load number of instance data block) loads the number of the opened instance data block into ACCU 1 after the content of ACCU 1 has been saved into ACCU 2.

Status word

	BR	CC 1	CC 0	OV	OS	OR	STA	RLO	/FC
writes:	-	-	-	-	-	-	-	-	-

6 Logic Control Instructions

6.1 Overview of Logic Control Instructions

Description

You can use the Jump instructions to control the flow of logic, enabling your program to interrupt its linear flow to resume scanning at a different point. You can use the LOOP instruction to call a program segment multiple times.

The address of a Jump or Loop instruction is a label. A jump label may be as many as four characters, and the first character must be a letter. Jump labels are followed with a mandatory colon ":" and must precede the program statement in a line.

Note

Please note for S7– 300 CPU programs that the jump destination always (not for 318– 2) forms the **beginning** of a Boolean logic string in the case of jump instructions. The jump destination must not be included in the logic string.

You can use the following jump instructions to interrupt the normal flow of your program unconditionally:

- JU Jump Unconditional
- JL Jump to Labels

The following jump instructions interrupt the flow of logic in your program based on the result of logic operation (RLO) produced by the previous instruction statement:

- JC Jump if RLO = 1
- JCN Jump if RLO = 0
- JCB Jump if RLO = 1 with BR
- JNB Jump if RLO = 0 with BR

The following jump instructions interrupt the flow of logic in your program based on the signal state of a bit in the status word:

- JBI Jump if BR = 1
- JNBI Jump if BR = 0
- JO Jump if OV = 1
- JOS Jump if OS = 1

The following jump instructions interrupt the flow of logic in your program based on the result of a calculation:

- JZ Jump if Zero
- JN Jump if Not Zero
- JP Jump if Plus
- JM Jump if Minus
- JPZ Jump if Plus or Zero
- JMZ Jump if Minus or Zero
- JUO Jump if Unordered

6.2 JU Jump Unconditional

Format

JU <jump label>

Address	Description
<jump label >	Symbolic name of jump destination.

Description

JU <jump label> interrupts the linear program scan and jumps to a jump destination, regardless of the status word contents. The linear program scan resumes at the jump destination. The jump destination is specified by a jump label. Both forward and backward jumps are possible. Jumps may be executed only within a block, that is, the jump instruction and the jump destination must lie within one and the same block. The jump destination must be unique within this block. The maximum jump distance is -32768 or +32767 words of program code. The actual maximum number of statements you can jump over depends on the mix of the statements used in your program (one-, two-, or three word statements).

Status word

	BR	CC 1	CC 0	OV	OS	OR	STA	RLO	/FC
writes:	-	-	-	-	-	-	-	-	-

Example

STL	Explanation	
A	I 1.0	
A	I 1.2	
JC	DELE	//Jump if RLO=1 to jump label DELE.
L	MB10	
INC	1	
T	MB10	
JU	FORW	//Jump unconditionally to jump label FORW.
DELE:	L 0	
	T MB10	
FORW:	A I 2.1	//Program scan resumes here after jump to jump label FORW.

6.3 JL Jump to Labels

Format

JL <jump label>

Address	Description
<jump label >	Symbolic name of jump destination.

Description

JL <jump label> (jump via jump to list) enables multiple jumps to be programmed. The jump target list, with a maximum of 255 entries, begins on the next line after the **JL** instruction and ends on the line before the jump label referenced in the **JL** address. Each jump destination consists of one **JU** instruction. The number of jump destinations (0 to 255) is taken from ACCU 1-L-L.

The **JL** instruction jumps to one of the **JU** instructions as long as the contents of the ACCU is smaller than the number of jump destinations between the **JL** instruction and the jump label. The first **JU** instruction is jumped to if ACCU 1-L-L=0. The second **JU** instruction is jumped to if ACCU 1-L-L=1, etc. The **JL** instruction jumps to the first instruction after the last **JU** instruction in the destination list if the number of jump destinations is too large.

The jump destination list must consist of **JU** instructions which precede the jump label referenced in the address of the **JL** instruction. Any other instruction within the jump list is illegal.

Status word

	BR	CC 1	CC 0	OV	OS	OR	STA	RLO	/FC
writes:	-	-	-	-	-	-	-	-	-

Example

STL	Explanation
L MB0	//Load jump destination number into ACCU 1-L-L.
JL LSTX	//Jump destination if ACCU 1-L-L > 3.
JU SEG0	//Jump destination if ACCU 1-L-L = 0.
JU SEG1	//Jump destination if ACCU 1-L-L = 1.
JU COMM	//Jump destination if ACCU 1-L-L = 2.
JU SEG3	//Jump destination if ACCU 1-L-L = 3.
LSTX: JU	COMM
SEG0: *	//Permitted instruction
*	
JU	COMM
SEG1: *	//Permitted instruction
*	
JU	COMM
SEG3: *	//Permitted instruction.
*	
JU	COMM
COMM: *	
*	

6.4 JC Jump if RLO = 1

Format

JC <jump label>

Address	Description
<jump label >	Symbolic name of jump destination.

Description

If the result of logic operation is 1, **JC <jump label>** interrupts the linear program scan and jumps to a jump destination. The linear program scan resumes at the jump destination. The jump destination is specified a jump label. Both forward and backward jumps are possible. Jumps may be executed only within a block, that is, the jump instruction and the jump destination must lie within one and the same block. The jump destination must be unique within this block. The maximum jump distance is -32768 or +32767 words of program code. The actual maximum number of statements you can jump over depends on the mix of the statements used in your program (one-, two-, or three word statements).

If the result of logic operation is 0, the jump is not executed. The RLO is set to 1, and the program scan continues with the next statement.

Status word

	BR	CC 1	CC 0	OV	OS	OR	STA	RLO	/FC
writes:	-	-	-	-	-	0	1	1	0

Example

STL	Explanation	
A	I 1.0	
A	I 1.2	
JC	JOVR	//Jump if RLO=1 to jump label JOVR.
L	IW8	//Program scan continues here if jump is not executed.
T	MW22	
JOVR:	A I 2.1	//Program scan resumes here after jump to jump label JOVR.

6.5 JCN Jump if RLO = 0

Format

JCN <jump label>

Address	Description
<jump label >	Symbolic name of jump destination.

Description

If the result of logic operation is 0, **JCN <jump label>** interrupts the linear program scan and jumps to a jump destination. The linear program scan resumes at the jump destination. The jump destination is specified by a jump label. Both forward and backward jumps are possible. Jumps may be executed only within a block, that is, the jump instruction and the jump destination must lie within one and the same block. The jump destination must be unique within this block. The maximum jump distance is -32768 or +32767 words of program code. The actual maximum number of statements you can jump over depends on the mix of the statements used in your program (one-, two-, or three word statements).

If the result of logic operation is 1, the jump is not executed. The program scan continues with the next statement.

Status word

	BR	CC 1	CC 0	OV	OS	OR	STA	RLO	/FC
writes:	-	-	-	-	-	0	1	1	0

Example

STL	Explanation
A I 1.0	
A I 1.2	
JCN JOVR	//Jump if RLO = 0 to jump label JOVR.
L IW8	//Program scan continues here if jump is not executed.
T MW22	
JOVR: A I 2.1	//Program scan resumes here after jump to jump label JOVR.

6.6 JCB Jump if RLO = 1 with BR

Format

JCB <jump label>

Address	Description
<jump label >	Symbolic name of jump destination.

Description

If the result of logic operation is 1, **JCB <jump label>** interrupts the linear program scan and jumps to a jump destination. The linear program scan resumes at the jump destination. The jump destination is specified by a jump label. Both forward and backward jumps are possible. Jumps may be executed only within a block, that is, the jump instruction and the jump destination must lie within one and the same block. The jump destination must be unique within this block. The maximum jump distance is -32768 or +32767 words of program code. The actual maximum number of statements you can jump over depends on the mix of the statements used in your program (one-, two-, or three word statements).

If the result of logic operation is 0, the jump is not executed. The RLO is set to 1, and the program scan continues with the next statement.

Independent of the RLO, the RLO is copied into the BR for the **JCB <jump label>** instruction.

Status word

	BR	CC 1	CC 0	OV	OS	OR	STA	RLO	/FC
writes:	x	-	-	-	-	0	1	1	0

Example

STL	Explanation
A I 1.0	
A I 1.2	
JCB JOVR	//Jump if RLO = 1 to jump label JOVR. Copy the contents of the RLO bit into the BR bit.
L IW8	//Program scan continues here if jump is not executed.
T MW22	
JOVR: A I 2.1	//Program scan resumes here after jump to jump label JOVR.

6.7 JNB Jump if RLO = 0 with BR

Format

JNB <jump label>

Address	Description
<jump label >	Symbolic name of jump destination.

Description

If the result of logic operation is 0, **JNB <jump label>** interrupts the linear program scan and jumps to a jump destination. The linear program scan resumes at the jump destination. The jump destination is specified by a jump label. Both forward and backward jumps are possible. Jumps may be executed only within a block, that is, the jump instruction and the jump destination must lie within one and the same block. The jump destination must be unique within this block. The maximum jump distance is -32768 or +32767 words of program code. The actual maximum number of statements you can jump over depends on the mix of the statements used in your program (one-, two-, or three word statements).

If the result of logic operation is 1, the jump is not executed. The RLO is set to 1 and the program scan continues with the next statement.

Independent of the RLO, the RLO is copied into the BR when there is a **JNB <jump label>** instruction.

Status word

	BR	CC 1	CC 0	OV	OS	OR	STA	RLO	/FC
writes:	x	-	-	-	-	0	1	1	0

Example

STL	Explanation
A I 1.0	
A I 1.2	
JNB JOVR	//Jump if RLO = 0 to jump label JOVR. Copy RLO bit contents into the BR bit.
L IW8	//Program scan continues here if jump is not executed.
T MW22	
JOVR: A I 2.1	//Program scan resumes here after jump to jump label JOVR.

6.8 JBI Jump if BR = 1

Format

JBI <jump label>

Address	Description
<jump label >	Symbolic name of jump destination.

Description

If status bit BR is 1, **JBI <jump label>** interrupts the linear program scan and jumps to a jump destination. The linear program scan resumes at the jump destination. The jump destination is specified by a jump label. A jump label may be as many as four characters, and the first character must be a letter. Jump labels are followed with a mandatory colon ":" and must precede the program statement in a line. Both forward and backward jumps are possible. Jumps may be executed only within a block, that is, the jump instruction and the jump destination must lie within one and the same block. The jump destination must be unique within this block. The maximum jump distance is -32768 or +32767 words of program code. The actual maximum number of statements you can jump over depends on the mix of the statements used in your program (one-, two-, or three word statements).

Status word

	BR	CC 1	CC 0	OV	OS	OR	STA	RLO	/FC
writes:	-	-	-	-	-	0	1	-	0

6.9 JNBI Jump if BR = 0

Format

JNBI <jump label>

Address	Description
<jump label >	Symbolic name of jump destination.

Description

If status bit BR is 0, **JNBI <jump label>** interrupts the linear program scan and jumps to a jump destination. The linear program scan resumes at the jump destination. The jump destination is specified by a jump label. Both forward and backward jumps are possible. Jumps may be executed only within a block, that is, the jump instruction and the jump destination must lie within one and the same block. The jump destination must be unique within this block. The maximum jump distance is -32768 or +32767 words of program code. The actual maximum number of statements you can jump over depends on the mix of the statements used in your program (one-, two-, or three word statements).

Status word

	BR	CC 1	CC 0	OV	OS	OR	STA	RLO	/FC
writes:	-	-	-	-	-	0	1	-	0

6.10 JO Jump if OV = 1

Format

JO <jump label>

Address	Description
<jump label >	Symbolic name of jump destination.

Description

If status bit OV is 1, **JO <jump label>** interrupts the linear program scan and jumps to a jump destination. The linear program scan resumes at the jump destination. The jump destination is specified by a jump label. Both forward and backward jumps are possible. Jumps may be executed only within a block, that is, the jump instruction and the jump destination must lie within one and the same block. The jump destination must be unique within this block. The maximum jump distance is -32768 or +32767 words of program code. The actual maximum number of statements you can jump over depends on the mix of the statements used in your program (one-, two-, or three word statements). In a combined math instruction, check for overflow after each separate math instruction to ensure that each intermediate result is within the permissible range, or use instruction **JOS**.

Status word

	BR	CC 1	CC 0	OV	OS	OR	STA	RLO	/FC
writes:	-	-	-	-	-	-	-	-	-

Example

STL	Explanation
L MW10	
L 3	
*I	//Multiply contents of MW10 by "3".
JO OVER	//Jump if result exceeds maximum range (OV=1).
T MW10	//Program scan continues here if jump is not executed.
A M 4.0	
R M 4.0	
JU NEXT	
OVER: AN M 4.0	//Program scan resumes here after jump to jump label OVER.
S M 4.0	
NEXT: NOP 0	//Program scan resumes here after jump to jump label NEXT.

6.11 JOS Jump if OS = 1

Format

JOS <jump label>

Address	Description
<jump label >	Symbolic name of jump destination.

Description

If status bit OS is 1, **JOS <jump label>** interrupts the linear program scan and jumps to a jump destination. The linear program scan resumes at the jump destination. The jump destination is specified by a jump label. Both forward and backward jumps are possible. Jumps may be executed only within a block, that is, the jump instruction and the jump destination must lie within one and the same block. The jump destination must be unique within this block. The maximum jump distance is -32768 or +32767 words of program code. The actual maximum number of statements you can jump over depends on the mix of the statements used in your program (one-, two-, or three word statements).

Status word

	BR	CC 1	CC 0	OV	OS	OR	STA	RLO	/FC
writes:	-	-	-	-	0	-	-	-	-

Example

STL	Explanation
L IW10	
L MW12	
*I	
L DBW25	
+I	
L MW14	
-I	
JOS OVER	//Jump if overflow in one of the three instructions during calculation OS=1. (See Note).
T MW16	//Program scan continues here if jump is not executed.
A M 4.0	
R M 4.0	
JU NEXT	
OVER: AN M 4.0	//Program scan resumes here after jump to jump label OVER.
S M 4.0	
NEXT: NOP 0	//Program scan resumes here after jump to jump label NEXT.

Note

In this case do not use the **JO** instruction. The **JO** instruction would only check the previous -I instruction if an overflow occurred.

6.12 JZ Jump if Zero

Format

JZ <jump label>

Address	Description
<jump label >	Symbolic name of jump destination.

Description

If status bits CC 1 = 0 and CC 0 = 0, **JZ <jump label>** (jump if result = 0) interrupts the linear program scan and jumps to a jump destination. The linear program scan resumes at the jump destination. The jump destination is specified by a jump label. Both forward and backward jumps are possible. Jumps may be executed only within a block, that is, the jump instruction and the jump destination must lie within one and the same block. The jump destination must be unique within this block. The maximum jump distance is -32768 or +32767 words of program code. The actual maximum number of statements you can jump over depends on the mix of the statements used in your program (one-, two-, or three word statements).

Status word

	BR	CC 1	CC 0	OV	OS	OR	STA	RLO	/FC
writes:	-	-	-	-	-	-	-	-	-

Example

STL	Explanation
L MW10	
SRW 1	
JZ ZERO	//Jump to jump label ZERO if bit that has been shifted out = 0.
L MW2	//Program scan continues here if jump is not executed.
INC 1	
T MW2	
JU NEXT	
ZERO: L MW4	//Program scan resumes here after jump to jump label ZERO.
INC 1	
T MW4	
NEXT: NOP 0	//Program scan resumes here after jump to jump label NEXT.

6.13 JN Jump if Not Zero

Format

JN <jump label>

Address	Description
<jump label >	Symbolic name of jump destination.

Description

If the result indicated by the status bits CC 1 and CC 0 is greater or less than zero (CC 1=0/CC 0=1 or CC 1=1/CC 0=0), **JN <jump label>** (jump if result \neq 0) interrupts the linear program scan and jumps to a jump destination. The linear program scan resumes at the jump destination. The jump destination is specified by a jump label. Both forward and backward jumps are possible. Jumps may be executed only within a block, that is, the jump instruction and the jump destination must lie within one and the same block. The jump destination must be unique within this block. The maximum jump distance is -32768 or +32767 words of program code. The actual maximum number of statements you can jump over depends on the mix of the statements used in your program (one-, two-, or three word statements).

Status word

	BR	CC 1	CC 0	OV	OS	OR	STA	RLO	/FC
writes:	-	-	-	-	-	-	-	-	-

Example

STL	Explanation
L IW8	
L MW12	
XOW	
JN NOZE	//Jump if the contents of ACCU 1-L are not equal to zero.
AN M 4.0	//Program scan continues here if jump is not executed.
S M 4.0	
JU NEXT	
NOZE: AN M 4.1	//Program scan resumes here after jump to jump label NOZE.
S M 4.1	
NEXT: NOP 0	//Program scan resumes here after jump to jump label NEXT.

6.14 JP Jump if Plus

Format

JP <jump label>

Address	Description
<jump label >	Symbolic name of jump destination.

Description

If status bits CC 1 = 1 and CC 0 = 0, **JP <jump label>** (jump if result < 0) interrupts the linear program scan and jumps to a jump destination. The linear program scan resumes at the jump destination. The jump destination is specified by a jump label. Both forward and backward jumps are possible. Jumps may be executed only within a block, that is, the jump instruction and the jump destination must lie within one and the same block. The jump destination must be unique within this block. The maximum jump distance is -32768 or +32767 words of program code. The actual maximum number of statements you can jump over depends on the mix of the statements used in your program (one-, two-, or three word statements).

Status word

	BR	CC 1	CC 0	OV	OS	OR	STA	RLO	/FC
writes:	-	-	-	-	-	-	-	-	-

Example

STL	Explanation	
L	IW8	
L	MW12	
-I		//Subtract contents of MW12 from contents of IW8.
JP	POS	//Jump if result >0 (that is, ACCU 1 > 0).
AN	M 4.0	//Program scan continues here if jump is not executed.
S	M 4.0	
JU	NEXT	
POS:	AN	M 4.1 //Program scan resumes here after jump to jump label POS.
	S	M 4.1
NEXT:	NOP 0	//Program scan resumes here after jump to jump label NEXT.

6.15 JM Jump if Minus

Format

JM <jump label>

Address	Description
<jump label >	Symbolic name of jump destination.

Description

If status bits CC 1 = 0 and CC 0 = 1, **JM <jump label>** (jump if result < 0) interrupts the linear program scan and jumps to a jump destination. The linear program scan resumes at the jump destination. The jump destination is specified by a jump label. Both forward and backward jumps are possible. Jumps may be executed only within a block, that is, the jump instruction and the jump destination must lie within one and the same block. The jump destination must be unique within this block. The maximum jump distance is -32768 or +32767 words of program code. The actual maximum number of statements you can jump over depends on the mix of the statements used in your program (one-, two-, or three word statements).

Status word

	BR	CC 1	CC 0	OV	OS	OR	STA	RLO	/FC
writes:	-	-	-	-	-	-	-	-	-

Example

STL	Explanation
L IW8	
L MW12	
-I	//Subtract contents of MW12 from contents of IW8.
JM NEG	//Jump if result < 0 (that is, contents of ACCU 1 < 0).
AN M 4.0	//Program scan continues here if jump is not executed.
S M 4.0	
JU NEXT	
NEG: AN M 4.1	//Program scan resumes here after jump to jump label NEG.
S M 4.1	
NEXT: NOP 0	//Program scan resumes here after jump to jump label NEXT.

6.16 JPZ Jump if Plus or Zero

Format

JPZ <jump label>

Address	Description
<jump label >	Symbolic name of jump destination.

Description

If the result indicated by the status bits CC 1 and CC 0 is greater than or equal to zero (CC 1=0/CC 0=0 or CC 1=1/CC 0=0), **JPZ <jump label>** (jump if result ≥ 0) interrupts the linear program scan and jumps to a jump destination. The linear program scan resumes at the jump destination. The jump destination is specified by a jump label. Both forward and backward jumps are possible. Jumps may be executed only within a block, that is, the jump instruction and the jump destination must lie within one and the same block. The jump destination must be unique within this block. The maximum jump distance is -32768 or +32767 words of program code. The actual maximum number of statements you can jump over depends on the mix of the statements used in your program (one-, two-, or three word statements).

Status word

	BR	CC 1	CC 0	OV	OS	OR	STA	RLO	/FC
writes:	-	-	-	-	-	-	-	-	

Example

STL	Explanation
L IW8	
L MW12	
-I	//Subtract contents of MW12 from contents of IW8.
JPZ REG0	//Jump if result ≥ 0 (that is, contents of ACCU 1 ≥ 0).
AN M 4.0	//Program scan continues here if jump is not executed.
S M 4.0	
JU NEXT	
REG0: AN M 4.1	//Program scan resumes here after jump to jump label REG0.
S M 4.1	
NEXT: NOP 0	//Program scan resumes here after jump to jump label NEXT.

6.17 JMZ Jump if Minus or Zero

Format

JMZ <jump label>

Address	Description
<jump label >	Symbolic name of jump destination.

Description

If the result indicated by the status bits CC 1 and CC 0 is less than or equal to zero (CC 1=0/CC 0=0 or CC 1=0/CC 0=1), **JMZ <jump label>** (jump if result ≤ 0) interrupts the linear program scan and jumps to a jump destination. The linear program scan resumes at the jump destination. The jump destination is specified by a jump label. Both forward and backward jumps are possible. Jumps may be executed only within a block, that is, the jump instruction and the jump destination must lie within one and the same block. The jump destination must be unique within this block. The maximum jump distance is -32768 or +32767 words of program code. The actual maximum number of statements you can jump over depends on the mix of the statements used in your program (one-, two-, or three word statements).

Status word

	BR	CC 1	CC 0	OV	OS	OR	STA	RLO	/FC
writes:	-	-	-	-	-	-	-	-	-

Example

STL	Explanation
L IW8	
L MW12	
-I	//Subtract contents of MW12 from contents of IW8.
JMZ RGE0	//Jump if result ≤ 0 (that is, contents of ACCU 1 ≤ 0).
AN M 4.0	//Program scan continues here if jump is not executed.
S M 4.0	
JU NEXT	
RGE0: AN M 4.1	//Program scan resumes here after jump to jump label RGE0.
S M 4.1	
NEXT: NOP 0	//Program scan resumes here after jump to jump label NEXT.

6.18 JUO Jump if Unordered

Format

JUO <jump label>

Address	Description
<jump label >	Symbolic name of jump destination.

Description

If status bits CC 1 = 1 and CC 0 = 1, **JUO <jump label>** interrupts the linear program scan and jumps to a jump destination. The linear program scan resumes at the jump destination. The jump destination is specified by a jump label. Both forward and backward jumps are possible. Jumps may be executed only within a block, that is, the jump instruction and the jump destination must lie within one and the same block. The jump destination must be unique within this block. The maximum jump distance is -32768 or +32767 words of program code. The actual maximum number of statements you can jump over depends on the mix of the statements used in your program (one-, two-, or three word statements).

Status bits CC 1 = 1 and CC 0 = 1 when

- A division by zero occurred
- An illegal instruction was used
- The result of a floating-point comparison is "unordered," that is, when a invalid format was used.

Status word

	BR	CC 1	CC 0	OV	OS	OR	STA	RLO	/FC
writes:	-	-	-	-	-	-	-	-	-

Example

STL	Explanation
L MD10	
L ID2	
/D	//Divide contents of MD10 by contents of ID2.
JUO ERRO	//Jump if division by zero (that is, ID2 = 0).
T MD14	//Program scan continues here if jump is not executed.
A M 4.0	
R M 4.0	
JU NEXT	
ERRO: AN M 4.0	//Program scan resumes here after jump to jump label ERRO.
S M 4.0	
NEXT: NOP 0	//Program scan resumes here after jump to jump label NEXT.

6.19 LOOP Loop

Format

LOOP <jump label>

Address	Description
<jump label >	Symbolic name of jump destination.

Description

LOOP <jump label> (decrement ACCU 1-L and jump if ACCU 1-L \neq 0) simplifies loop programming. The loop counter is accommodated in ACCU 1-L. The instruction jumps to the specified jump destination. The jump is executed as long as the content of ACCU 1-L is not equal to 0. The linear program scan resumes at the jump destination. The jump destination is specified by a jump label. Both forward and backward jumps are possible. Jumps may be executed only within a block, that is, the jump instruction and the jump destination must lie within one and the same block. The jump destination must be unique within this block. The maximum jump distance is -32768 or +32767 words of program code. The actual maximum number of statements you can jump over depends on the mix of the statements used in your program (one-, two-, or three word statements).

Status word

	BR	CC 1	CC 0	OV	OS	OR	STA	RLO	/FC
writes:	-	-	-	-	-	-	-	-	-

Example for calculating the factor of 5

STL	Explanation
L L#1	//Load the integer constant (32 bit) into ACCU 1.
T MD20	//Transfer the contents from ACCU 1 into MD20 (initialization).
L 5	//Load number of loop cycles into ACCU 1-L.
NEXT: T MW10	//Jump label = loop start / transfer ACCU 1-L to loop counter.
L MD20	
* D	//Multiply current contents of MD20 by the current contents of MB10.
T MD20	//Transfer the multiplication result to MD20.
L MW10	//Load contents of loop counter into ACCU 1.
LOOP NEXT	//Decrement the contents of ACCU 1 and jump to the NEXT jump label if ACCU 1-L > 0.
L MW24	//Program scan resumes here after loop is finished.
L 200	
>I	

7 Integer Math Instructions

7.1 Overview of Integer Math Instructions

Description

The math operations combine the contents of accumulators 1 and 2. In the case of CPUs with two accumulators, the contents of accumulator 2 remains unchanged.

In the case of CPUs with four accumulators, the contents of accumulator 3 is then copied into accumulator 2 and the contents of accumulator 4 into accumulator 3. The old contents of accumulator 4 remains unchanged.

Using integer math, you can carry out the following operations with **two integer numbers** (16 and 32 bits):

- +I Add ACCU 1 and ACCU 2 as Integer (16-Bit)
- -I Subtract ACCU 1 from ACCU 2 as Integer (16-Bit)
- *I Multiply ACCU 1 and ACCU 2 as Integer (16-Bit)
- /I Divide ACCU 2 by ACCU 1 as Integer (16-Bit)
- + Add Integer Constant (16, 32 Bit)
- +D Add ACCU 1 and ACCU 2 as Double Integer (32-Bit)
- -D Subtract ACCU 1 from ACCU 2 as Double Integer (32-Bit)
- *D Multiply ACCU 1 and ACCU 2 as Double Integer (32-Bit)
- /D Divide ACCU 2 by ACCU 1 as Double Integer (32-Bit)
- MOD Division Remainder Double Integer (32-Bit)

7.2 Evaluating the Bits of the Status Word with Integer Math Instructions

Description

The integer math instructions influence the following bits in the Status word: CC1 and CC0, OV and OS.

The following tables show the signal state of the bits in the status word for the results of instructions with Integers (16 and 32 bits):

Valid Range for the Result	CC 1	CC 0	OV	OS
0 (zero)	0	0	0	*
16 bits: $-32\,768 \leq \text{result} < 0$ (negative number) 32 bits: $-2\,147\,483\,648 \leq \text{result} < 0$ (negative number)	0	1	0	*
16 bits: $32\,767 \geq \text{result} > 0$ (positive number) 32 bits: $2\,147\,483\,647 \geq \text{result} > 0$ (positive number)	1	0	0	*

* The OS bit is not affected by the result of the instruction.

Invalid Range for the Result	A1	A0	OV	OS
Underflow (addition) 16 bits: result = -65536 32 bits: result = -4 294 967 296	0	0	1	1
Underflow (multiplication) 16 bits: result < -32 768 (negative number) 32 bits: result < -2 147 483 648 (negative number)	0	1	1	1
Overflow (addition, subtraction) 16 bits: result > 32 767 (positive number) 32 bits: result > 2 147 483 647 (positive number)	0	1	1	1
Overflow (multiplication, division) 16 bits: result > 32 767 (positive number) 32 bits: result > 2 147 483 647 (positive number)	1	0	1	1
Underflow (addition, subtraction) 16 bits: result < -32. 768 (negative number) 32 bits: result < -2 147 483 648 (negative number)	1	0	1	1
Division by 0	1	1	1	1

Operation	A1	A0	OV	OS
+D: result = -4 294 967 296	0	0	1	1
/D or MOD: division by 0	1	1	1	1

7.3 +I Add ACCU 1 and ACCU 2 as Integer (16-Bit)

Format

+I

Description

+I (add 16-bit integer numbers) adds the contents of ACCU 1-L to the contents of ACCU 2-L and stores the result in ACCU 1-L. The contents of ACCU 1-L and ACCU 2-L are interpreted as 16-bit integer numbers. The instruction is executed without regard to, and without affecting, the RLO. The status word bits CC 1, CC 0, OS, and OV are set as a function of the result of the instruction. The instruction produces a 16-bit integer number instead of an 32-bit integer number in the event of an overflow/underflow.

The contents of accumulator 2 remain unchanged for CPUs with two ACCUs.

The contents of accumulator 3 are copied into accumulator 2, and the contents of accumulator 4 are copied into accumulator 3 for CPUs with four ACCUs. The contents of accumulator 4 remain unchanged.

See also Evaluating the Bits of the Status Word with Integer Math Instructions.

Status word

	BR	CC 1	CC 0	OV	OS	OR	STA	RLO	/FC
writes:	-	x	x	x	x	-	-	-	-

Status bit generation	CC 1	CC 0	OV	OS
Sum = 0	0	0	0	-
-32768 <= Sum < 0	0	1	0	-
32767 >= Sum > 0	1	0	0	-
Sum = -65536	0	0	1	1
65534 >= Sum > 32767	0	1	1	1
-65535 <= Sum < -32768	1	0	1	1

Example

STL	Explanation
L IW10	//Load the value of IW10 into ACCU 1-L.
L MW14	//Load the contents of ACCU 1-L into ACCU 2-L. Load the value of MW14 into ACCU 1-L.
+I	//Add ACCU 2-L and ACCU 1-L; store the result in ACCU 1-L.
T DB1.DBW25	//The contents of ACCU 1-L (result) are transferred to DBW25 of DB1.

7.4 -I Subtract ACCU 1 from ACCU 2 as Integer (16-Bit)

Format

-I

Description

-I (subtract 16-bit integer numbers) subtracts the contents of ACCU 1-L from the contents of ACCU 2-L and stores the result in ACCU 1-L. The contents of ACCU 1-L and ACCU 2-L are interpreted as 16-bit integer numbers. The instruction is executed without regard to, and without affecting, the RLO. The status word bits CC 1, CC 0, OS, and OV are set as a function of the result of the instruction. The instruction produces a 16-bit integer number instead of a 32-bit integer number in the event of an overflow/underflow.

The contents of accumulator 2 remain unchanged for CPUs with two ACCUs.

The contents of accumulator 3 are copied into accumulator 2, and the contents of accumulator 4 are copied into accumulator 3 for CPUs with four ACCUs. The contents of accumulator 4 remain unchanged.

See also Evaluating the Bits of the Status Word with Integer Math Instructions.

Status word

	BR	CC 1	CC 0	OV	OS	OR	STA	RLO	/FC
writes:	-	x	x	x	x	-	-	-	-

Status bit generation	CC 1	CC 0	OV	OS
Difference = 0	0	0	0	-
-32768 <= Difference < 0	0	1	0	-
32767 >= Difference > 0	1	0	0	-
65535 >= Difference > 32767	0	1	1	1
-65535 <= Difference < -32768	1	0	1	1

Example

STL	Explanation
L IW10	//Load the value of IW10 into ACCU 1-L.
L MW14	//Load the contents of ACCU 1-L into ACCU 2-L. Load the value of MW14 into ACCU 1-L.
-I	//Subtract ACCU 1-L from ACCU 2-L; store the result in ACCU 1-L.
T DB1.DBW25	//The contents of ACCU 1-L (result) are transferred to DBW25 of DB1.

7.5 *I Multiply ACCU 1 and ACCU 2 as Integer (16-Bit)

Format

*I

Description

*I (multiply 16-bit integer numbers) multiplies the contents of ACCU 2-L by the contents of ACCU 1-L. The contents of ACCU 1-L and ACCU 2-L are interpreted as 16-bit integer numbers. The result is stored in accumulator 1 as a 32-bit integer number. If the status word bits are $OV1 = 1$ and $OS = 1$, the result is outside the range of a 16-bit integer number.

The instruction is executed without regard to, and without affecting, the RLO. The status word bits CC 1, CC 0, OS, and OV are set as a function of the result of the instruction.

The contents of accumulator 2 remain unchanged for CPUs with two ACCUs.

The contents of accumulator 3 are copied into accumulator 2, and the contents of accumulator 4 are copied into accumulator 3 for CPUs with four ACCUs.

See also Evaluating the Bits of the Status Word with Integer Math Instructions.

Status word

	BR	CC 1	CC 0	OV	OS	OR	STA	RLO	/FC
writes:	-	x	x	x	x	-	-	-	-

Status bit generation	CC 1	CC 0	OV	OS
Product = 0	0	0	0	-
$-32768 \leq \text{Product} < 0$	0	1	0	-
$32767 \geq \text{Product} > 0$	1	0	0	-
$1073741824 \geq \text{Product} > 32767$	1	0	1	1
$-1073709056 \leq \text{Product} < -32768$	0	1	1	1

Example

STL	Explanation
L IW10	//Load the value of IW10 into ACCU 1-L.
L MW14	//Load contents of ACCU 1-L into ACCU 2-L. Load contents of MW14 into ACCU 1-L.
*I	//Multiply ACCU 2-L and ACCU 1-L, store result in ACCU 1.
T DB1.DB25	//The contents of ACCU 1 (result) are transferred to DB25 in DB1.

7.6 /I Divide ACCU 2 by ACCU 1 as Integer (16-Bit)

Format

/I

Description

/I (divide 16-bit integer numbers) divides the contents of ACCU 2-L by the contents of ACCU 1-L. The contents of ACCU 1-L and ACCU 2-L are interpreted as 16-bit integer numbers. The result is stored in accumulator 1 and consists of two 16-bit integer numbers, the quotient, and the remainder. The quotient is stored in ACCU 1-L and the remainder in ACCU 1-H. The instruction is executed without regard to, and without affecting, the RLO. The status word bits CC 1, CC 0, OS, and OV are set as a function of the result of the instruction.

The contents of accumulator 2 remain unchanged for CPUs with two ACCUs.

The contents of accumulator 3 are copied into accumulator 2, and the contents of accumulator 4 are copied into accumulator 3 for CPUs with four ACCUs. The contents of accumulator 4 remain unchanged.

See also Evaluating the Bits of the Status Word with Integer Math Instructions.

Status word

	BR	CC 1	CC 0	OV	OS	OR	STA	RLO	/FC
writes:	-	x	x	x	x	-	-	-	-

Status bit generation	CC 1	CC 0	OV	OS
Quotient = 0	0	0	0	-
-32768 <= Quotient < 0	0	1	0	-
32767 >= Quotient > 0	1	0	0	-
Quotient = 32768	1	0	1	1
Division by zero	1	1	1	1

Example

STL	Explanation
L IW10	//Load the value of IW10 into ACCU 1-L.
L MW14	//Load the contents of ACCU 1-L into ACCU 2-L. Load the value of MW14 into ACCU 1-L.
/I	//Divide ACCU 2-L by ACCU 1-L; store the result in ACCU 1: ACCU 1-L: quotient, ACCU 1-H: remainder
T MD20	//The contents of ACCU 1 (result) are transferred to MD20.

Example: 13 divided by 4

Contents of ACCU 2-L before instruction (IW10):	"13"
Contents of ACCU 1-L before instruction (MW14):	"4"
Instruction /I (ACCU 2-L / ACCU 1-L):	"13/4"
Contents of ACCU 1-L after instruction (quotient):	"3"
Contents of ACCU 1-H after instruction (remainder):	"1"

7.7 + Add Integer Constant (16, 32-Bit)

Format

+ <integer constant>

Address	Data type	Description
<integer constant>	(16, or 32-bit integer)	Constant to be added

Description

+ <integer constant> adds the integer constant to the contents of ACCU 1 and stores the result in ACCU 1. The instruction is executed without regard to, and without affecting, the status word bits.

+ <16-bit integer constant>: Adds a 16-bit integer constant (in the range of -32768 to +32767) to the contents of ACCU 1-L and stores the result in ACCU 1-L.

+ <32-bit integer constant>: Adds a 32-bit integer constant (in the range of -2,147,483,648 to 2,147,483,647) to the contents of ACCU 1 and stores the result in ACCU 1.

Status word

	BR	CC 1	CC 0	OV	OS	OR	STA	RLO	/FC
writes:	-	-	-	-	-	-	-	-	-

Example 1

STL	Explanation
L IW10	//Load the value of IW10 into ACCU 1-L.
L MW14	//Load the contents of ACCU 1-L to ACCU 2-L. Load the value of MW14 into ACCU 1-L.
+I	//Add ACCU 2-L and ACCU 1-L; store the result in ACCU 1-L.
+ 25	//Add ACCU 1-L and 25; store the result in ACCU 1-L.
T DB1.DBW25	//Transfer the contents of ACCU 1-L (result) to DBW25 of DB1.

Example 2

STL	Explanation
L IW12	
L IW14	
+ 100	//Add ACCU 1-L and 100; store the result in ACCU 1-L.
>I	//If ACCU 2 > ACCU 1, or IW12 > (IW14 + 100)
JC NEXT	//then conditional jump to jump label NEXT.

Example 3

STL	Explanation
L MD20	
L MD24	
+D	//Add ACCU 1and ACCU 2; store the result in ACCU 1.
+ L#-200	//Add ACCU 1 and -200; store the result in ACCU 1.
T MD28	

7.8 +D Add ACCU 1 and ACCU 2 as Double Integer (32-Bit)

Format

+D

Description

+D (add 32-bit integer numbers) adds the contents of ACCU 1 to the contents of ACCU 2 and stores the result in ACCU 1. The contents of ACCU 1 and ACCU 2 are interpreted as 32-bit integer numbers. The instruction is executed without regard to, and without affecting, the RLO. The status word bits CC 1, CC 0, OS, and OV are set as a function of the result of the instruction.

The contents of accumulator 2 remain unchanged for CPUs with two ACCUs.

The contents of accumulator 3 are copied into accumulator 2, and the contents of accumulator 4 are copied into accumulator 3 for CPUs with four ACCUs. The contents of accumulator 4 remain unchanged.

See also Evaluating the Bits of the Status Word with Integer Math Instructions.

Status word

	BR	CC 1	CC 0	OV	OS	OR	STA	RLO	/FC
writes:	-	x	x	x	x	-	-	-	-

Status bit generation	CC 1	CC 0	OV	OS
Sum = 0	0	0	0	-
-2147483648 <= Sum < 0	0	1	0	-
2147483647 >= Sum > 0	1	0	0	-
Sum = -4294967296	0	0	1	1
4294967294 >= Sum > 2147483647	0	1	1	1
-4294967295 <= Sum < -2147483648	1	0	1	1

Example

STL	Explanation
L ID10	//Load the value of ID10 into ACCU 1.
L MD14	//Load the contents of ACCU 1 to ACCU 2. Load the value of MD14 into ACCU 1.
+D	//Add ACCU 2 and ACCU 1; store the result in ACCU 1.
T DB1.DBD25	//The contents of ACCU 1 (result) are transferred to DBD25 of DB1.

7.9 -D Subtract ACCU 1 from ACCU 2 as Double Integer (32-Bit)

Format

-D

Description

-D (subtract 32-bit integer numbers) subtracts the contents of ACCU 1 from the contents of ACCU 2 and stores the result in ACCU 1. The contents of ACCU 1 and ACCU 2 are interpreted as 32-bit integer numbers. The instruction is executed without regard to, and without affecting, the RLO. The status word bits CC 1, CC 0, OS, and OV are set as a function of the result of the instruction.

The contents of accumulator 2 remain unchanged for CPUs with two ACCUs.

The contents of accumulator 3 are copied into accumulator 2, and the contents of accumulator 4 are copied into accumulator 3 for CPUs with four ACCUs. The contents of accumulator 4 remain unchanged.

See also Evaluating the Bits of the Status Word with Integer Math Instructions.

Status word

	BR	CC 1	CC 0	OV	OS	OR	STA	RLO	/FC
writes:	-	x	x	x	x	-	-	-	-

Status bit generation	CC 1	CC 0	OV	OS
Difference = 0	0	0	0	-
-2147483648 <= Difference < 0	0	1	0	-
2147483647 >= Difference > 0	1	0	0	-
4294967295 >= Difference > 2147483647	0	1	1	1
-4294967295 <= Difference < -2147483648	1	0	1	1

Example

STL	Explanation
L ID10	//Load the value of ID10 into ACCU 1.
L MD14	//Load the contents of ACCU 1 into ACCU 2. Load the value of MD14 into ACCU 1.
-D	//Subtract ACCU 1 from ACCU 2; store the result in ACCU 1.
T DB1.DB25	//The contents of ACCU 1 (result) are transferred to DB25 of DB1.

7.10 *D Multiply ACCU 1 and ACCU 2 as Double Integer (32-Bit)

Format

*D

Description

***D** (multiply 32-bit integer numbers) multiplies the contents of ACCU 2 by the contents of ACCU 1. The contents of ACCU 1 and ACCU 2 are interpreted as 32-bit integer numbers. The result is stored in accumulator 1 as a 32-bit integer number. If the status word bits are $OV1 = 1$ and $OS = 1$, the result is outside the range of a 32-bit integer number.

The instruction is executed without regard to, and without affecting, the RLO. The status word bits CC 1, CC 0, OS, and OV are set as a function of the result of the instruction.

The contents of accumulator 2 remain unchanged for CPUs with two ACCUs.

The contents of accumulator 3 are copied into accumulator 2, and the contents of accumulator 4 are copied into accumulator 3 for CPUs with four ACCUs. The contents of accumulator 4 remain unchanged.

See also Evaluating the Bits of the Status Word with Integer Math Instructions.

Status word

	BR	CC 1	CC 0	OV	OS	OR	STA	RLO	/FC
writes:	-	x	x	x	x	-	-	-	-

Status bit generation	CC 1	CC 0	OV	OS
Product = 0	0	0	0	-
$-2147483648 \leq \text{Product} < 0$	0	1	0	-
$2147483647 \geq \text{Product} > 0$	1	0	0	-
Product > 2147483647	1	0	1	1
Product < -2147483648	0	1	1	1

Example

STL	Explanation
L ID10	//Load the value of ID10 into ACCU 1.
L MD14	//Load contents of ACCU 1 into ACCU 2. Load contents of MD14 into ACCU 1.
*D	//Multiply ACCU 2 and ACCU 1; store the result in ACCU 1.
T DB1.DB25	//The contents of ACCU 1 (result) are transferred to DB25 in DB1.

7.11 /D Divide ACCU 2 by ACCU 1 as Double Integer (32-Bit)

Format

/D

Description

/D (divide 32-bit integer numbers) divides the contents of ACCU 2 by the contents of ACCU 1. The contents of ACCU 1 and ACCU 2 are interpreted as 32-bit integer numbers. The result of the instruction is stored in accumulator 1. The result gives only the quotient and not the remainder. (The instruction MOD can be used to get the remainder.)

The instruction is executed without regard to, and without affecting, the RLO. The status word bits CC 1, CC 0, OS, and OV are set as a function of the result of the instruction.

The contents of accumulator 2 remain unchanged for CPUs with two ACCUs.

The contents of accumulator 3 are copied into accumulator 2, and the contents of accumulator 4 are copied into accumulator 3 for CPUs with four ACCUs. The contents of accumulator 4 remain unchanged.

See also Evaluating the Bits of the Status Word with Integer Math Instructions.

Status word

	BR	CC 1	CC 0	OV	OS	OR	STA	RLO	/FC
writes:	-	x	x	x	x	-	-	-	-

Status bit generation	CC 1	CC 0	OV	OS
Quotient = 0	0	0	0	-
-2147483648 <= Quotient < 0	0	1	0	-
2147483647 >= Quotient > 0	1	0	0	-
Quotient = 2147483648	1	0	1	1
Division by zero	1	1	1	1

Example

STL		Explanation
L	ID10	//Load the value of ID10 into ACCU 1.
L	MD14	//Load the contents of ACCU 1 into ACCU 2. Load the value of MD14 into ACCU 1.
/D		//Divide ACCU 2 by ACCU 1; store the result (quotient) in ACCU 1.
T	MD20	//The contents of ACCU 1 (result) are transferred to MD20.

Example: 13 divided by 4

Contents of ACCU 2 before instruction (ID10):	"13"
Contents of ACCU 1 before instruction (MD14):	"4"
Instruction /D (ACCU 2 / ACCU 1):	"13/4"
Contents of ACCU 1 after instruction (quotient):	"3"

7.12 MOD Division Remainder Double Integer (32-Bit)

Format

MOD

Description

MOD (remainder of the division of 32-bit integer numbers) divides the contents of ACCU 2 by the contents of ACCU 1. The contents of ACCU 1 and ACCU 2 are interpreted as 32-bit integer numbers. The result of the instruction is stored in accumulator 1. The result gives only the division remainder, and not the quotient. (The instruction /D can be used to get the quotient.)

The instruction is executed without regard to, and without affecting, the RLO. The status word bits CC 1, CC 0, OS, and OV are set as a function of the result of the instruction.

The contents of accumulator 2 remain unchanged for CPUs with two ACCUs.

The contents of accumulator 3 are copied into accumulator 2, and the contents of accumulator 4 are copied into accumulator 3 for CPUs with four ACCUs. The contents of accumulator 4 remain unchanged.

Status word

	BR	CC 1	CC 0	OV	OS	OR	STA	RLO	/FC
writes:	-	x	x	x	x	-	-	-	-

Status bit generation	CC 1	CC 0	OV	OS
Remainder = 0	0	0	0	-
-2147483648 <= Remainder < 0	0	1	0	-
2147483647 >= Remainder > 0	1	0	0	-
Division by zero	1	1	1	1

Example

STL		Explanation
L	ID10	//Load the value of ID10 into ACCU 1.
L	MD14	//Load the contents of ACCU 1 into ACCU 2. Load the value of MD14 into ACCU 1.
MOD		//Divide ACCU 2 by ACCU 1, store the result (remainder) in ACCU 1.
T	MD20	//The contents of ACCU 1 (result) are transferred to MD20.

Example: 13 divided by 4

Contents of ACCU 2 before instruction (ID10):	"13"
Contents of ACCU 1 before instruction (MD14):	"4"
Instruction MOD (ACCU 2 / ACCU 1):	"13/4"
Contents of ACCU 1 after instruction (remainder):	"1"

8 Floating-Point Math Instructions

8.1 Overview of Floating-Point Math Instructions

Description

The math instructions combine the contents of accumulators 1 and 2. In the case of CPUs with two accumulators, the contents of accumulator 2 remains unchanged.

In the case of CPUs with four accumulators, the contents of accumulator 3 is copied into accumulator 2 and the contents of accumulator 4 into accumulator 3. The old contents of accumulator 4 remains unchanged.

The IEEE 32-bit floating-point numbers belong to the data type called REAL. You can use the floating-point math instructions to perform the following math instructions using **two 32-bit IEEE floating-point numbers**:

- +R Add ACCU 1 and ACCU
- -R Subtract ACCU 1 from ACCU 2
- *R Multiply ACCU 1 and ACCU 2
- /R Divide ACCU 2 by ACCU 1

Using floating-point math, you can carry out the following operations with **one 32-bit IEEE floating-point number**:

- ABS Absolute Value
- SQR Generate the Square
- SQRT Generate the Square Root
- EXP Generate the Exponential Value
- LN Generate the Natural Logarithm
- SIN Generate the Sine of Angles
- COS Generate the Cosine of Angles
- TAN Generate the Tangent of Angles
- ASIN Generate the Arc Sine
- ACOS Generate the Arc Cosine
- ATAN Generate the Arc Tangent

8.2 Evaluating the Bits of the Status Word with Floating-Point Math Instructions

Description

The basic arithmetic types influence the following bits in the Status word: CC 1 and CC 0, OV and OS.

The following tables show the signal state of the bits in the status word for the results of instructions with floating-point numbers (32 bits):

Valid Area for a Result	CC 1	CC 0	OV	OS
+0, -0 (Null)	0	0	0	*
$-3.402823E+38 < \text{result} < -1.175494E-38$ (negative number)	0	1	0	*
$+1.175494E-38 < \text{result} < 3.402824E+38$ (positive number)	1	0	0	*

* The OS bit is not affected by the result of the instruction.

Invalid Area for a Result	CC 1	CC 0	OV	OS
Underflow $-1.175494E-38 < \text{result} < -1.401298E-45$ (negative number)	0	0	1	1
Underflow $+1.401298E-45 < \text{result} < +1.175494E-38$ (positive number)	0	0	1	1
Overflow Result $< -3.402823E+38$ (negative number)	0	1	1	1
Overflow Result $> 3.402823E+38$ (positive number)	1	0	1	1
Not a valid floating-point number or illegal instruction (input value outside the valid range)	1	1	1	1

8.3 Floating-Point Math Instructions: Basic

8.3.1 +R Add ACCU 1 and ACCU 2 as a Floating-Point Number (32-Bit IEEE-FP)

Format

+R

Description of instruction

+R (add 32-bit IEEE floating-point numbers) adds the contents of accumulator 1 to the contents of accumulator 2 and stores the result in accumulator 1. The contents of accumulator 1 and accumulator 2 are interpreted as 32-bit IEEE floating-point numbers. The instruction is executed without regard to, and without affecting, the RLO. The status bits CC 1, CC 0, OS, and OV are set as a function of the result of the instruction.

The contents of accumulator 2 remain unchanged for CPUs with two ACCUs.

The contents of accumulator 3 are copied into accumulator 2, and the contents of accumulator 4 are copied into accumulator 3 for CPUs with four ACCUs. The contents of accumulator 4 remain unchanged.

Result

The result in ACCU 1 is	CC 1	CC 0	OV	OS	Note
+qNaN	1	1	1	1	
+infinite	1	0	1	1	Overflow
+normalized	1	0	0	-	
+denormalized	0	0	1	1	Underflow
+zero	0	0	0	-	
-zero	0	0	0	-	
-denormalized	0	0	1	1	Underflow
-normalized	0	1	0	-	
-infinite	0	1	1	1	Overflow
-qNaN	1	1	1	1	

Status word

	BR	CC 1	CC 0	OV	OS	OR	STA	RLO	/FC
writes:	-	x	x	x	x	-	-	-	-

Example

STL	Explanation
OPN DB10	
L ID10	//Load the value of ID10 into ACCU 1.
L MD14	//Load the value of ACCU 1 into ACCU 2. Load the value of MD14 into ACCU 1.
+R	//Add ACCU 2 and ACCU 1; store the result in ACCU 1.
T DBD25	//The content of ACCU 1 (result) is transferred to DBD25 in DB10.

8.3.2 -R Subtract ACCU 1 from ACCU 2 as a Floating-Point Number (32-Bit IEEE-FP)

Format

-R

Description

-R (subtract 32-bit IEEE floating-point numbers) subtracts the contents of accumulator 1 from the contents of accumulator 2 and stores the result in accumulator 1. The contents of accumulator 1 and accumulator 2 are interpreted as 32-bit IEEE floating-point numbers. The result is stored in accumulator 1. The instruction is executed without regard to, and without affecting, the RLO. The status bits CC 1, CC 0, OS, and OV are set as a function of the result of the instruction.

The contents of accumulator 2 remain unchanged for CPUs with two ACCUs.

The contents of accumulator 3 are copied into accumulator 2, and the contents of accumulator 4 are copied into accumulator 3 for CPUs with four ACCUs. The contents of accumulator 4 remain unchanged.

Result

The result in ACCU 1 is	CC 1	CC 0	OV	OS	Note
+qNaN	1	1	1	1	
+infinite	1	0	1	1	Overflow
+normalized	1	0	0	-	
+denormalized	0	0	1	1	Underflow
+zero	0	0	0	-	
-zero	0	0	0	-	
-denormalized	0	0	1	1	Underflow
-normalized	0	1	0	-	
-infinite	0	1	1	1	Overflow
-qNaN	1	1	1	1	

Status word

	BR	CC 1	CC 0	OV	OS	OR	STA	RLO	/FC
writes:	-	x	x	x	x	-	-	-	-

Example

STL		Explanation
OPN	DB10	
L	ID10	//Load the value of ID10 into ACCU 1.
L	MD14	//Load the value of ACCU 1 into ACCU 2. Load the value of MD14 into ACCU 1.
-R		//Subtract ACCU 1 from ACCU 2; store the result in ACCU 1.
T	DBD25	//The content of ACCU 1 (result) is transferred to DBD25 in DB10.

8.3.3 *R Multiply ACCU 1 and ACCU 2 as Floating-Point Numbers (32-Bit IEEE-FP)

Format

*R

Description of instruction

*R (multiply 32-bit IEEE floating-point numbers) multiplies the contents of accumulator 2 by the contents of accumulator 1. The contents of accumulator 1 and accumulator 2 are interpreted as 32-bit IEEE floating-point numbers. The result is stored in accumulator 1 as a 32-bit IEEE floating-point number. The instruction is executed without regard to, and without affecting, the RLO. The status bits CC 1, CC 0, OS, and OV are set as a result of the instruction.

The contents of accumulator 2 remain unchanged for CPUs with two ACCUs.

The contents of accumulator 3 are copied into accumulator 2, and the contents of accumulator 4 are copied into accumulator 3 for CPUs with four ACCUs. The contents of accumulator 4 remain unchanged.

Result

The result in ACCU 1 is	CC 1	CC 0	OV	OS	Note
+qNaN	1	1	1	1	
+infinite	1	0	1	1	Overflow
+normalized	1	0	0	-	
+denormalized	0	0	1	1	Underflow
+zero	0	0	0	-	
-zero	0	0	0	-	
-denormalized	0	0	1	1	Underflow
-normalized	0	1	0	-	
-infinite	0	1	1	1	Overflow
-qNaN	1	1	1	1	

Status word

	BR	CC 1	CC 0	OV	OS	OR	STA	RLO	/FC
writes:	-	x	x	x	x	-	-	-	-

Example

STL	Explanation
OPN DB10	
L ID10	//Load the value of ID10 into ACCU 1.
L MD14	//Load the value of ACCU 1 into ACCU 2. Load the value of MD14 into ACCU 1.
*R	//Multiply ACCU 2 and ACCU 1; store the result in ACCU 1.
T DBD25	//The content of ACCU 1 (result) is transferred to DBD25 in DB10.

8.3.4 /R Divide ACCU 2 by ACCU 1 as a Floating-Point Number (32-Bit IEEE-FP)

Format

/R

Description of instruction

/R (divide 32-bit IEEE floating-point numbers) divides the contents of accumulator 2 by the contents of accumulator 1. The contents of accumulator 1 and accumulator 2 are interpreted as 32-bit IEEE floating-point numbers. The instruction is executed without regard to, and without affecting, the RLO. The status bits CC 1, CC 0, OS, and OV are set as a function of the result of the instruction.

The contents of accumulator 2 remain unchanged for CPUs with two ACCUs.

The contents of accumulator 3 are copied into accumulator 2, and the contents of accumulator 4 are copied into accumulator 3 for CPUs with four ACCUs.

Result

The result in ACCU 1 is	CC 1	CC 0	OV	OS	Note
+qNaN	1	1	1	1	
+infinite	1	0	1	1	Overflow
+normalized	1	0	0	-	
+denormalized	0	0	1	1	Underflow
+zero	0	0	0	-	
-zero	0	0	0	-	
-denormalized	0	0	1	1	Underflow
-normalized	0	1	0	-	
-infinite	0	1	1	1	Overflow
-qNaN	1	1	1	1	

Status word

	BR	CC 1	CC 0	OV	OS	OR	STA	RLO	/FC
writes:	-	x	x	x	x	-	-	-	-

Example

STL	Explanation
OPN DB10	
L ID10	//Load the value of ID10 into ACCU 1.
L MD14	//Load the contents of ACCU 1 into ACCU 2. Load the value of MD14 into ACCU 1.
/R	//Divide ACCU 2 by ACCU 1; store the result in ACCU 1.
T DBD20	//The content of ACCU 1 (result) is transferred to DBD20 in DB10.

8.3.5 ABS Absolute Value of a Floating-Point Number (32-Bit IEEE-FP)

Format

ABS

Description

ABS (absolute value of a 32-bit IEEE FP) produces the absolute value of a floating-point number (32-bit IEEE floating-point number) in ACCU 1. The result is stored in accumulator 1. The instruction is executed without regard to, and without affecting, the status bits.

Status word

	BR	CC 1	CC 0	OV	OS	OR	STA	RLO	/FC
writes:	-	-	-	-	-	-	-	-	-

Example

STL	Explanation
L ID8	//Load value into ACCU 1 (example: ID8 = -1.5E+02).
ABS	//Form the absolute value; store the result in ACCU 1.
T MD10	//Transfer result to MD10 (example: result = 1.5E+02).

8.4 Floating-Point Math Instructions: Extended

8.4.1 SQR Generate the Square of a Floating-Point Number (32-Bit)

Format

SQR

Description of instruction

SQR (generate the square of an IEEE-FP 32-bit floating-point number) calculates the square of a floating-point number (32-bit, IEEE-FP) in ACCU 1. The result is stored in accumulator 1. The instruction influences the CC 1, CC 0, OV, and OS status word bits.

The contents of accumulator 2 (and also the contents of accumulator 3 and accumulator 4 for CPUs with four ACCUs) remain unchanged.

Result

The result in ACCU 1 is	CC 1	CC 0	OV	OS	Note
+qNaN	1	1	1	1	
+infinite	1	0	1	1	Overflow
+normalized	1	0	0	-	
+denormalized	0	0	1	1	Underflow
+zero	0	0	0	-	
-qNaN	1	1	1	1	

Example

STL	Explanation
OPN DB17	//Open data block DB17.
L DBD0	//The value from data double word DBD0 is loaded into ACCU 1. (This value must be in the floating-point format.)
SQR	//Calculate the square of the floating-point number (32-bit, IEEE-FP) in ACCU 1. Store the result in ACCU 1.
AN OV	//Scan the OV bit in the status word for "0."
JC OK	//If no error occurred during the SQR instruction, jump to the OK jump label.
BEU	//Block end unconditional, if an error occurred during the SQR instruction.
OK: T DBD4	//Transfer the result from ACCU 1 to data double word DBD4.

8.4.2 SQRT Generate the Square Root of a Floating-Point Number (32-Bit)

Format

SQRT

Description of instruction

SQRT (generate the square root of a 32-bit, IEEE-FP floating-point number) calculates the square root of a floating-point number (32-bit, IEEE-FP) in ACCU 1. The result is stored in accumulator 1. The input value must be greater than or equal to zero. The result is then positive. Only exception the square root of -0 is -0. The instruction influences the CC 1, CC 0, OV, and OS status word bits.

The contents of accumulator 2 (and also the contents of accumulator 3 and accumulator 4 for CPUs with four ACCUs) remain unchanged.

Result

The result in ACCU 1 is	CC 1	CC 0	OV	OS	Note
+qNaN	1	1	1	1	
+infinite	1	0	1	1	Overflow
+normalized	1	0	0	-	
+denormalized	0	0	1	1	Underflow
+zero	0	0	0	-	
-zero	0	0	0	-	
-qNaN	1	1	1	1	

Example

STL		Explanation
L	MD10	//The value from memory double word MD10 is loaded into ACCU 1. (This value must be in the floating-point format.)
SQRT		//Calculate the square root of the floating-point number (32-bit, IEEE-FP) in ACCU 1. Store the result in ACCU 1.
AN	OV	//Scan the OV bit in the status word for "0."
JC	OK	//If no error occurred during the SQRT instruction, jump to the OK jump label.
BEU		//Block end unconditional, if an error occurred during the SQRT instruction.
OK:	T MD20	//Transfer the result from ACCU 1 to memory double word MD20.

8.4.3 EXP Generate the Exponential Value of a Floating-Point Number (32-Bit)

Format

EXP

Description of instruction

EXP (generate the exponential value of a floating-point number, 32-bit, IEEE-FP) calculates the exponential value (exponential value for base e) of a floating-point number (32-bit, IEEE-FP) in ACCU 1. The result is stored in accumulator 1. The instruction influences the CC 1, CC 0, OV, and OS status word bits.

The contents of accumulator 2 (and also the contents of accumulator 3 and accumulator 4 for CPUs with four ACCUs) remain unchanged.

Result

The result in ACCU 1 is	CC 1	CC 0	OV	OS	Note
+qNaN	1	1	1	1	
+infinite	1	0	1	1	Overflow
+normalized	1	0	0	-	
+denormalized	0	0	1	1	Underflow
+zero	0	0	0	-	
-qNaN	1	1	1	1	

Example

STL	Explanation
L MD10	//The value from memory double word MD10 is loaded into ACCU 1. (This value must be in the floating-point format.)
EXP	//Calculate the exponential value of the floating-point number (32-bit, IEEE-FP) in ACCU 1 at base e . Store the result in ACCU 1.
AN OV	//Scan the OV bit in the status word for "0."
JC OK	//If no error occurred during the EXP instruction, jump to the OK jump label.
BEU	//Block end unconditional, if an error occurred during the EXP instruction.
OK: T MD20	//Transfer the result from ACCU 1 to memory double word MD20.

8.4.4 LN Generate the Natural Logarithm of a Floating-Point Number (32-Bit)

Format

LN

Description of instruction

LN (generate the natural logarithm of an IEEE-FP 32-bit floating-point number) calculates the natural logarithm (logarithm to base *e*) of a floating-point number (32-bit, IEEE-FP) in ACCU 1. The result is stored in accumulator 1. The input value must be greater than zero. The instruction influences the CC 1, CC 0, UO, and OV status word bits.

The contents of accumulator 2 (and also the contents of accumulator 3 and accumulator 4 for CPUs with four ACCUs) remain unchanged.

Result

The result in ACCU 1 is	CC 1	CC 0	OV	OS	Note
+qNaN	1	1	1	1	
+infinite	1	0	1	1	Overflow
+normalized	1	0	0	-	
+denormalized	0	0	1	1	Underflow
+zero	0	0	0	-	
-zero	0	0	0	-	
-denormalized	0	0	1	1	Underflow
-normalized	0	1	0	-	
-infinite	0	1	1	1	Overflow
-qNaN	1	1	1	1	

Example

STL	Explanation
L MD10	//The value from memory double word MD10 is loaded into ACCU 1. (This value must be in the floating-point format.)
LN	//Calculate the natural logarithm of the floating-point number (32-bit, IEEE-FP) in ACCU 1. Store the result in ACCU 1.
AN OV	//Scan the OV bit in the status word for "0."
JC OK	//If no error occurred during the instruction, jump to the OK jump label.
BEU	//Block end unconditional, if an error occurred during the instruction.
OK: T MD20	//Transfer the result from ACCU 1 to memory double word MD20.

8.4.5 SIN Generate the Sine of Angles as Floating-Point Numbers (32-Bit)

Format

SIN

Description of instruction

SIN (generate the sine of angles as floating-point numbers, 32-bit, IEEE-FP) calculates the sine of an angle specified as a radian measure. The angle must be present as a floating-point number in ACCU 1. The result is stored in accumulator 1. The instruction influences the CC 1, CC 0, OV, and OS status word bits.

The contents of accumulator 2 (and the contents of accumulator 3 and accumulator 4 for CPUs with four ACCUs) remain unchanged.

Result

The result in ACCU 1 is	CC 1	CC 0	OV	OS	Note
+qNaN	1	1	1	1	
+normalized	1	0	0	-	
+denormalized	0	0	1	1	Overflow
+zero	0	0	0	-	
-zero	0	0	0	-	
-denormalized	0	0	1	1	Underflow
-normalized	0	1	0	-	
-qNaN	1	1	1	1	

Example

STL	Explanation
L MD10	//The value from memory double word MD10 is loaded into ACCU 1. (This value must be in the floating-point format.)
SIN	//Calculate the sine of the floating-point number (32-bit, IEEE-FP) in ACCU 1. Store the result in ACCU 1.
T MD20	//Transfer the result from ACCU 1 to the memory double word MD20.

8.4.6 COS Generate the Cosine of Angles as Floating-Point Numbers (32-Bit)

Format

COS

Description of instruction

COS (generate the cosine of angles as floating-point numbers, 32-bit, IEEE-FP) calculates the cosine of an angle specified as a radian measure. The angle must be present as a floating-point number in ACCU 1. The result is stored in accumulator 1. The instruction influences the CC 1, CC 0, OV, and OS status word bits.

The contents of accumulator 2 (and the contents of accumulator 3 and accumulator 4 for CPUs with four ACCUs) remain unchanged.

Result

The result in ACCU 1 is	CC 1	CC 0	OV	OS	Note
+qNaN	1	1	1	1	
+normalized	1	0	0	-	
+denormalized	0	0	1	1	Overflow
+zero	0	0	0	-	
-zero	0	0	0	-	
-denormalized	0	0	1	1	Underflow
-normalized	0	1	0	-	
-qNaN	1	1	1	1	

Example

STL	Explanation
L MD10	//The value from memory double word MD10 is loaded into ACCU 1. (This value must be in the floating-point format.)
COS	//Calculate the cosine of the floating-point number (32-bit, IEEE-FP) in ACCU 1. Store the result in ACCU 1.
T MD20	//Transfer the result from ACCU 1 to memory double word MD20.

8.4.7 TAN Generate the Tangent of Angles as Floating-Point Numbers (32-Bit)

Format

TAN

Description of instruction

TAN (generate the tangent of angles as floating-point numbers, 32-bit, IEEE-FP) calculates the tangent of an angle specified as a radian measure. The angle must be present as a floating-point number in ACCU 1. The result is stored in accumulator 1. The instruction influences the CC 1, CC 0, OV, and OS status word bits.

The contents of accumulator 2 (and the contents of accumulator 3 and accumulator 4 for CPUs with four ACCUs) remain unchanged.

Result

The result in ACCU 1 is	CC 1	CC 0	OV	OS	Note
+qNaN	1	1	1	1	
+infinite	1	0	1	1	Overflow
+normalized	1	0	0	-	
+denormalized	0	0	1	1	Underflow
+zero	0	0	0	-	
-zero	0	0	0	-	
-denormalized	0	0	1	1	Underflow
-normalized	0	1	0	-	
-infinite	0	1	1	1	Overflow
-qNaN	1	1	1	1	

Example

STL	Explanation
L MD10	//The value from memory double word MD10 is loaded into ACCU 1. (This value must be in the floating-point format.)
TAN	//Calculate the tangent of the floating-point number (32-bit, IEEE-FP) in ACCU 1. Store the result in ACCU 1.
AN OV	//Scan the OV bit in the status word for "0."
JC OK	//If no error occurred during the TAN instruction, jump to the OK jump label.
BEU	//Block end unconditional, if an error occurred during the TAN instruction.
OK: T MD20	//Transfer the result from ACCU 1 to memory double word MD20.

8.4.8 ASIN Generate the Arc Sine of a Floating-Point Number (32-Bit)

Format

ASIN

Description of instruction

ASIN (generate the arc sine of a floating-point number, 32-bit, IEEE-FP) calculates the arc sine of a floating-point number in ACCU 1. Permissible value range for the input value

$$-1 \leq \text{input value} \leq +1$$

The result is an angle specified as a radian measure. The value is in the following range

$$-\pi / 2 \leq \text{arc sine (ACCU1)} \leq +\pi / 2, \text{ with } \pi = 3.14159\dots$$

The instruction influences the CC 1, CC 0, OV, and OS status word bits.

The contents of accumulator 2 (and also the contents of accumulator 3 and accumulator 4 for CPUs with four ACCUs) remain unchanged.

Result

The result in ACCU 1 is	CC 1	CC 0	OV	OS	Note
+qNaN	1	1	1	1	
+normalized	1	0	0	-	
+denormalized	0	0	1	1	Overflow
+zero	0	0	0	-	
-zero	0	0	0	-	
-denormalized	0	0	1	1	Underflow
-normalized	0	1	0	-	
-qNaN	1	1	1	1	

Example

STL	Explanation
L MD10	//The value from memory double word MD10 is loaded into ACCU 1. (This value must be in the floating-point format.)
ASIN	//Calculate the arc sine of the floating-point number (32-bit, IEEE-FP) in ACCU 1. Store the result in ACCU 1.
AN OV	//Scan the OV bit in the status word for "0."
JC OK	//If no error occurred during the ASIN instruction, jump to the OK jump label.
BEU	//Block end unconditional, if an error occurred during the ASIN instruction.
OK: T MD20	//Transfer the result from ACCU 1 to the memory double word MD20.

8.4.9 ACOS Generate the Arc Cosine of a Floating-Point Number (32-Bit)

Format

ACOS

Description of instruction

ACOS (generate the arc cosine of a floating-point number, 32-bit, IEEE-FP) calculates the arc cosine of a floating-point number in ACCU 1. Permissible value range for the input value
 $-1 \leq \text{input value} \leq +1$

The result is an angle specified in a radian measure. The value is located in the following range

$$0 \leq \text{arc cosine (ACCU1)} \leq \pi, \text{ with } \pi = 3.14159\dots$$

The instruction influences the CC 1, CC 0, OV, and OS status word bits.

The contents of accumulator 2 (and the contents of accumulator 3 and accumulator 4 for CPUs with four ACCUs) remain unchanged.

Result

The result in ACCU 1 is	CC 1	CC 0	OV	OS	Note
+qNaN	1	1	1	1	
+normalized	1	0	0	-	
+denormalized	0	0	1	1	Overflow
+zero	0	0	0	-	
-zero	0	0	0	-	
-denormalized	0	0	1	1	Underflow
-normalized	0	1	0	-	
-qNaN	1	1	1	1	

Example

STL	Explanation
L MD10	//The value from memory double word MD10 is loaded into ACCU 1. (This value must be in the floating-point format.)
ACOS	//Calculate the arc cosine of the floating-point number (32-bit, IEEE-FP) in ACCU 1. Store the result in ACCU 1.
AN OV	//Scan the OV bit in the status word for "0."
JC OK	//If no error occurred during the ACOS instruction, jump to the OK jump label.
BEU	//Block end unconditional, if an error occurred during the ACOS instruction.
OK: T MD20	//Transfer the result from ACCU 1 to memory double word MD20.

8.4.10 ATAN Generate the Arc Tangent of a Floating-Point Number (32-Bit)

Format

ATAN

Description of instruction

ATAN (generate the arc tangent of a floating-point number, 32-bit, IEEE-FP) calculates the arc tangent of a floating-point number in ACCU 1. The result is an angle specified in a radian measure. The value is in the following range

$$-\pi / 2 \leq \text{arc tangent (ACCU1)} \leq +\pi / 2, \text{ with } \pi = 3.14159\dots$$

The instruction influences the CC 1, CC 0, OV, and OS status word bits.

The contents of accumulator 2 (and also the contents of accumulator 3 and accumulator 4 for CPUs with four ACCUs) remain unchanged.

Result

The result in ACCU 1 is	CC 1	CC 0	OV	OS	Note
+qNaN	1	1	1	1	
+normalized	1	0	0	-	
+denormalized	0	0	1	1	Overflow
+zero	0	0	0	-	
-zero	0	0	0	-	
-denormalized	0	0	1	1	Underflow
-normalized	0	1	0	-	
-qNaN	1	1	1	1	

Example

STL	Explanation
L MD10	//The value from memory double word MD10 is loaded into ACCU 1. (This value must be in the floating-point format.)
ATAN	//Calculate the arc tangent of the floating-point number (32-bit, IEEE-FP) in ACCU 1. Store the result in ACCU 1.
AN OV	//Scan the OV bit in the status word for "0,"
JC OK	//If no error occurred during the ATAN instruction, jump to the OK jump label.
BEU	//Block end unconditional, if an error occurred during the ATAN instruction
OK: T MD20	//Transfer the result from ACCU 1 to memory double word MD20.

9 Load and Transfer Instructions

9.1 Overview of Load and Transfer Instructions

Description

The Load (L) and Transfer (T) instructions enable you to program an interchange of information between input or output modules and memory areas, or between memory areas. The CPU executes these instructions in each scan cycle as unconditional instructions, that is, they are not affected by the result of logic operation of a statement.

The following Load and Transfer instructions are available:

- L Load
- L STW Load Status Word into ACCU 1
- LAR1 AR2 Load Address Register 1 from Address Register 2
- LAR1 <D> Load Address Register 1 with Double Integer (32-Bit Pointer)
- LAR1 Load Address Register 1 from ACCU 1
- LAR2 <D> Load Address Register 2 with Double Integer (32-Bit Pointer)
- LAR2 Load Address Register 2 from ACCU 1

- T Transfer
- T STW Transfer ACCU 1 into Status Word
- TAR1 AR2 Transfer Address Register 1 to Address Register 2
- TAR1 <D> Transfer Address Register 1 to Destination (32-Bit Pointer)
- TAR2 <D> Transfer Address Register 2 to Destination (32-Bit Pointer)
- TAR1 Transfer Address Register 1 to ACCU 1
- TAR2 Transfer Address Register 2 to ACCU 1
- CAR Exchange Address Register 1 with Address Register 2

9.2 L Load

Format

L <address>

Address	Data type	Memory area	Source address
<address>	BYTE	E, A, PE, M, L, D,	0...65535
	WORD	Pointer, Parameter	0...65534
	DWORD		0...65532

Description

L <address> loads the addressed byte, word, or double word into ACCU 1 after the old contents of ACCU 1 have been saved into ACCU 2, and ACCU 1 is reset to "0".

Status word

	BR	CC 1	CC 0	OV	OS	OR	STA	RLO	/FC
writes:	-	-	-	-	-	-	-	-	-

Examples

STL	Explanation
L IB10	//Load input byte IB10 into ACCU 1-L-L.
L MB120	//Load memory byte MB120 into ACCU 1-L-L.
L DBB12	//Load data byte DBB12 into ACCU 1-L-L.
L DIW15	//Load instance data word DIW15 into ACCU 1-L.
L LD252	//Load local data double word LD252 ACCU 1.
L P# I 8.7	//Load the pointer into ACCU 1.
L OTTO	//Load the parameter "OTTO" into ACCU 1.
L P# ANNA	//Load the pointer to the specified parameter in ACCU 1. (This instruction loads the relative address offset of the specified parameter. To calculate the absolute offset in the instance data block in multiple instance FBs, the contents of the AR2 register must be added to this value.

Contents of ACCU 1

Contents of ACCU 1	ACCU1-H-H	ACCU1-H-L	ACCU1-L-H	ACCU1-L-L
before execution of load instruction	XXXXXXXX	XXXXXXXX	XXXXXXXX	XXXXXXXX
after execution of L MB10 (L <Byte>)	00000000	00000000	00000000	<MB10>
after execution of L MW10 (L <word>)	00000000	00000000	<MB10>	<MB11>
after execution of L MD10 (L <double word>)	<MB10>	<MB11>	<MB12>	<MB13>
after execution of L P# ANNA (in FB)	<86>	<Bit offset of ANNA relative to the FB start>. To calculate the absolute offset in the instance data block in multiple instance FBs, the contents of the AR2 register must be added to this value.		
after execution of L P# ANNA (in FC)	<An area-crossing address of the data which is transferred to ANNA>			
	X = "1" or "0"			

9.3 L STW Load Status Word into ACCU 1

Format

L STW

Description

L STW (instruction L with the address STW) loads ACCU 1 with the contents of the status word. The instruction is executed without regard to, and without affecting, the status bits.

Note

For the S7-300 series CPUs, the statement **L STW** does not load the FC, STA, and OR bits of the status word. Only bits 1, 4, 5, 6, 7, and 8 are loaded into the corresponding bit positions of the low word of accumulator 1.

Status word

	BR	CC 1	CC 0	OV	OS	OR	STA	RLO	/FC
writes:	-	-	-	-	-	-	-	-	-

Example

STL	Explanation
L STW	//Load contents of status word into ACCU 1.

The contents of ACCU 1 after the execution of **L STW** is:

Bit	31-9	8	7	6	5	4	3	2	1	0
Content:	0	BR	CC 1	CC 0	OV	OS	OR	STA	RLO	/FC

9.4 LAR1 Load Address Register 1 from ACCU 1

Format

LAR1

Description

LAR1 loads address register AR1 with the contents of ACCU 1 (32-bit pointer). ACCU 1 and ACCU 2 remain unchanged. The instruction is executed without regard to, and without affecting, the status bits.

Status word

	BR	CC 1	CC 0	OV	OS	OR	STA	RLO	/FC
writes:	-	-	-	-	-	-	-	-	-

9.5 LAR1 <D> Load Address Register 1 with Double Integer (32-Bit Pointer)

Format

LAR1 <D>

Address	Data type	Memory area	Source address
<D>	DWORD pointer constant	D, M, L	0..65532

Description

LAR1 <D> loads address register AR1 with the contents of the addressed double word <D> or a pointer constant. ACCU 1 and ACCU 2 remain unchanged. The instruction is executed without regard to, and without affecting, the status bits.

Status word

	BR	CC 1	CC 0	OV	OS	OR	STA	RLO	/FC
writes:	-	-	-	-	-	-	-	-	-

Example: Direct addresses

STL	Explanation
LAR1 DBD20	//Load AR1 with the pointer in data double word DBD20.
LAR1 DID30	//Load AR1 with the pointer in instance data double word DID30.
LAR1 LD180	//Load AR1 with the pointer in local data double word LD180.
LAR1 MD24	//Load AR1 with the contents of memory double word MD24.

Example: Pointer constant

STL	Explanation
LAR1 P#M100.0	//Load AR1 with a 32-bit pointer constant.

9.6 LAR1 AR2 Load Address Register 1 from Address Register 2

Format

LAR1 AR2

Description

LAR1 AR2 (instruction LAR1 with the address AR2) loads address register AR1 with the contents of address register AR2. ACCU 1 and ACCU 2 remain unchanged. The instruction is executed without regard to, and without affecting, the status bits.

Status word

	BR	CC 1	CC 0	OV	OS	OR	STA	RLO	/FC
writes:	-	-	-	-	-	-	-	-	-

9.7 LAR2 Load Address Register 2 from ACCU 1

Format

LAR2

Description

LAR2 loads address register AR2 with the contents ACCU 1 (32-bit pointer).

ACCU 1 and ACCU 2 remain unchanged. The instruction is executed without regard to, and without affecting, the status bits.

Status word

	BR	CC 1	CC 0	OV	OS	OR	STA	RLO	/FC
writes:	-	-	-	-	-	-	-	-	-

9.8 LAR2 <D> Load Address Register 2 with Double Integer (32-Bit Pointer)

Format

LAR2 <D>

Address	Data type	Memory area	Source address
<D>	DWORD pointer constant	D, M, L	0..65532

Description

LAR2 <D> loads address register AR2 with the contents of the addressed double word <D> or a pointer constant. ACCU 1 and ACCU 2 remain unchanged. The instruction is executed without regard to, and without affecting, the status bits.

Status word

	BR	CC 1	CC 0	OV	OS	OR	STA	RLO	/FC
writes:	-	-	-	-	-	-	-	-	-

Example: Direct addresses

STL	Explanation
LAR2 DBD 20	//Load AR2 with the pointer in data double word DBD20.
LAR2 DID 30	//Load AR2 with the pointer in instance data double word DID30.
LAR2 LD 180	//Load AR2 with the pointer in local data double word LD180.
LAR2 MD 24	//Load AR2 with the pointer in memory double word MD24.

Example: Pointer constant

STL	Explanation
LAR2 P#M100.0	//Load AR2 with a 32-bit pointer constant.

9.9 T Transfer

Format

T <address>

Address	Data type	Memory area	Source address
<address>	BYTE	I, Q, PQ, M, L, D	0...65535
	WORD		0...65534
	DWORD		0...65532

Description

T <address> transfers (copies) the contents of ACCU 1 to the destination address if the Master Control Relay is switched on (MCR = 1). If MCR = 0, then the destination address is written with 0. The number of bytes copied from ACCU 1 depends on the size expressed in the destination address. ACCU 1 also saves the data after the transfer procedure. A transfer to the direct I/O area (memory type PQ) also transfers the contents of ACCU 1 or "0" (if MCR=0) to the corresponding address of the process image output table (memory type Q). The instruction is executed without regard to, and without affecting, the status bits.

Status word

	BR	CC 1	CC 0	OV	OS	OR	STA	RLO	/FC
writes:	-	-	-	-	-	-	-	-	-

Examples

STL	Explanation
T QB10	//Transfers contents of ACCU 1-L-L to output byte QB10.
T MW14	//Transfers contents of ACCU 1-L to memory word MW14.
T DBD2	//Transfers contents of ACCU 1 to data double word DBD2.

9.10 T STW Transfer ACCU 1 into Status Word

Format

T STW

Description

T STW (instruction T with the address STW) transfers bit 0 to bit 8 of ACCU 1 into the status word.

The instruction is executed without regard to the status bits.

Status word

	BR	CC 1	CC 0	OV	OS	OR	STA	RLO	/FC
writes:	x	x	x	x	x	x	x	x	x

Example

STL	Explanation
T STW	//Transfer bit 0 to bit 8 from ACCU 1 to the status word.

The bits in ACCU 1 contain the following status bits:

Bit	31-9	8	7	6	5	4	3	2	1	0
Content:	*)	BR	CC 1	CC 0	OV	OS	OR	STA	RLO	/FC

*) bits are not transferred.

9.11 CAR Exchange Address Register 1 with Address Register 2

Format

CAR

Description

CAR (swap address register) exchanges the contents of address registers AR1 and AR2. The instruction is executed without regard to, and without affecting, the status bits.

The contents of address register AR1 are moved to address register AR2 and the contents of address register AR2 are moved to address register AR1.

Status word

	BR	CC 1	CC 0	OV	OS	OR	STA	RLO	/FC
writes:	-	-	-	-	-	-	-	-	-

9.12 TAR1 Transfer Address Register 1 to ACCU 1

Format

TAR1

Description

TAR1 transfers the contents of address register AR1 into ACCU 1 (32-bit pointer). The previous contents of ACCU 1 are saved into ACCU 2. The instruction is executed without regard to, and without affecting, the status bits.

Status word

	BR	CC 1	CC 0	OV	OS	OR	STA	RLO	/FC
writes:	-	-	-	-	-	-	-	-	-

9.13 TAR1 <D> Transfer Address Register 1 to Destination (32-Bit Pointer)

Format

TAR1 <D>

Address	Data type	Memory area	Source address
<D>	DWORD	D, M, L	0..65532

Description

TAR1 <D> transfers the contents of address register AR1 into the addressed double word <D>. Possible destination areas are memory double words (MD), local data double words (LD), data double words (DBD), and instance data words (DID).

ACCU 1 and ACCU 2 remain unchanged. The instruction is executed without regard to, and without affecting, the status bits.

Status word

	BR	CC 1	CC 0	OV	OS	OR	STA	RLO	/FC
writes:	-	-	-	-	-	-	-	-	-

Examples

STL	Explanation
TAR1 DBD20	//Transfer the contents of AR1 into data double word DBD20.
TAR1 DID30	//Transfer the contents of AR1 into instance data double word DID30.
TAR1 LD18	//Transfer the contents of AR1 into local data double word LD18.
TAR1 MD24	//Transfer the contents of AR1 into memory double word MD24.

9.14 TAR1 AR2 Transfer Address Register 1 to Address Register 2

Format

TAR1 AR2

Description

TAR1 AR2 (instruction TAR1 with the address AR2) transfers the contents of address register AR1 to address register AR2.

ACCU 1 and ACCU 2 remain unchanged. The instruction is executed without regard to, and without affecting, the status bits.

Status word

	BR	CC 1	CC 0	OV	OS	OR	STA	RLO	/FC
writes:	-	-	-	-	-	-	-	-	-

9.15 TAR2 Transfer Address Register 2 to ACCU 1

Format

TAR2

Description

TAR2 transfers the contents of address register AR2 into ACCU 1 (32-bit pointer). The contents of ACCU 1 were previously saved into ACCU 2. The instruction is executed without regard to, and without affecting, the status bits.

Status word

	BR	CC 1	CC 0	OV	OS	OR	STA	RLO	/FC
writes:	-	-	-	-	-	-	-	-	-

9.16 TAR2 <D> Transfer Address Register 2 to Destination (32-Bit Pointer)

Format

TAR2 <D>

Address	Data type	Memory area	Source address
<D>	DWORD	D, M, L	0..65532

Description

TAR2 <D> transfers the contents of address register AR2 to the addressed double word <D>. Possible destination areas are memory double words (MD), local data double words (LD), data double words (DBD), and instance double words (DID).

ACCU 1 and ACCU 2 remain unchanged. The instruction is executed without regard to, and without affecting, the status bits.

Status word

	BR	CC 1	CC 0	OV	OS	OR	STA	RLO	/FC
writes:	-	-	-	-	-	-	-	-	-

Examples

STL	Explanation
TAR2 DBD20	//Transfer the contents of AR2 to data double word DBD20.
TAR2 DID30	//Transfer the contents of AR2 to instance double word DID30.
TAR2 LD18	//Transfer the contents of AR2 into local data double word LD18.
TAR2 MD24	//Transfer the contents of AR2 into memory double word MD24.

10 Program Control Instructions

10.1 Overview of Program Control Instructions

Description

The following instructions are available for performing program control instructions:

- BE Block End
- BEC Block End Conditional
- BEU Block End Unconditional
- CALL Block Call
- CC Conditional Call
- UC Unconditional Call

- Call FB
- Call FC
- Call SFB
- Call SFC
- Call Multiple Instance
- Call Block from a Library

- MCR (Master Control Relay)
- Important Notes on Using MCR Functions
- MCR(Save RLO in MCR Stack, Begin MCR
-)MCR End MCR
- MCRA Activate MCR Area
- MCRD Deactivate MCR Area

10.2 BE Block End

Format

BE

Description

BE (block end) terminates the program scan in the current block and causes a jump to the block that called the current block. The program scan resumes with the first instruction that follows the block call statement in the calling program. The current local data area is released and the previous local data area becomes the current local data area. The data blocks that were opened when the block was called are re-opened. In addition, the MCR dependency of the calling block is restored and the RLO is carried over from the current block to the block that called the current block. BE is not dependent on any conditions. However, if the BE instruction is jumped over, the current program scan does not end and will continue starting at the jump destination within the block.

The BE instruction is not identical to the S5 software. The instruction has the same function as BEU when used on S7 hardware.

Status word

	BR	CC 1	CC 0	OV	OS	OR	STA	RLO	/FC
writes:	-	-	-	-	0	0	1	-	0

Example

STL	Explanation
A I 1.0	
JC NEXT	//Jump to NEXT jump label if RLO = 1 (I 1.0 = 1).
L IW4	//Continue here if no jump is executed.
T IW10	
A I 6.0	
A I 6.1	
S M 12.0	
BE	//Block end
NEXT: NOP	//Continue here if jump is executed.
0	

10.3 BEC Block End Conditional

Format

BEC

Description

If RLO = 1, then **BEC** (block end conditional) interrupts the program scan in the current block and causes a jump to the block that called the current block. The program scan resumes with the first instruction that follows the block call. The current local data area is released and the previous local data area becomes the current local data area. The data blocks that were current data blocks when the block was called are re-opened. The MCR dependency of the calling block is restored.

The RLO (= 1) is carried over from the terminated block to the block that called. If RLO = 0, then BEC is not executed. The RLO is set to 1 and the program scan continues with the instruction following BEC.

Status word

	BR	CC 1	CC 0	OV	OS	OR	STA	RLO	/FC
writes:	-	-	-	-	x	0	1	1	0

Example

STL	Explanation
A I 1.0	//Update RLO.
BEC	//End block if RLO = 1.
L IW4	//Continue here if BEC is not executed, RLO = 0.
T MW10	

10.4 BEU Block End Unconditional

Format

BEU

Description

BEU (block end unconditional) terminates the program scan in the current block and causes a jump to the block that called the current block. The program scan resumes with the first instruction that follows the block call. The current local data area is released and the previous local data area becomes the current local data area. The data blocks that were opened when the block was called are re-opened. In addition, the MCR dependency of the calling block is restored and the RLO is carried over from the current block to the block that called the current block. BEU is not dependent on any conditions. However, if the BEU instruction is jumped over, the current program scan does not end and will continue starting at the jump destination within the block.

Status word

	BR	CC 1	CC 0	OV	OS	OR	STA	RLO	/FC
writes:	-	-	-	-	0	0	1	-	0

Example

STL	Explanation
A I 1.0	
JC NEXT	//Jump to NEXT jump label if RLO = 1 (I 1.0 = 1).
L IW4	//Continue here if no jump is executed.
T IW10	
A I 6.0	
A I 6.1	
S M 12.0	
BEU	//Block end unconditional.
NEXT: NOP 0	//Continue here if jump is executed.

10.5 CALL Block Call

Format

CALL <logic block identifier>

Description

CALL <logic block identifier> is used to call functions (FCs) or function blocks (FBs), system functions (SFCs) or system function blocks (SFBs) or to call the standard pre-programmed blocks shipped by Siemens. The CALL instruction calls the FC and SFC or the FB and SFB that you input as an address, independent of the RLO or any other condition. If you call an FB or SFB with CALL, you must provide the block with an associated instance DB. The calling block program continues logic processing after the called block is processed. The address for the logic block can be specified absolutely or symbolically. Register contents are restored after an SFB/SFC call.

Example: CALL FB1, DB1 or CALL FILLVAT1, RECIPE1

Logic Block	Block Type	Absolute Address Call Syntax
FC	Function	CALL FCn
SFC	System function	CALL SFCn
FB	Function block	CALL FBn1,DBn2
SFB	System function block	CALL SFBn1,DBn2

Note

When you use the STL Editor, the references (n, n1, and n2) in the table above must refer to valid existing blocks. Likewise, symbolic names must be defined prior to use.

Passing parameters (incremental edit mode)

The calling block can exchange parameters with the called block via a variable list. The variable list is extended automatically in your STL program when you enter a valid CALL statement.

If you call an FB, SFB, FC or SFC and the variable declaration table of the called block has IN, OUT, and IN_OUT declarations, these variables are added in the calling block as a formal parameter list.

When FCs and SFCs are called, you must assign actual parameters from the calling logic block to the formal parameters.

When you call FBs and SFBs, you must specify only the actual parameters that must be changed from the previous call. After the FB is processed, the actual parameters are stored in the instance DB. If the actual parameter is a data block, the complete, absolute address must be specified, for example DB1, DBW2.

The IN parameters can be specified as constants or as absolute or symbolic addresses. The OUT and IN_OUT parameters must be specified as absolute or symbolic addresses. You must ensure that all addresses and constants are compatible with the data types to be transferred.

CALL saves the return address (selector and relative address), the selectors of the two current data blocks, as well as the MA bit in the B (block) stack. In addition, CALL deactivates the MCR dependency, and then creates the local data area of the block to be called.

Status word

	BR	CC 1	CC 0	OV	OS	OR	STA	RLO	/FC
writes:	-	-	-	-	0	0	1	-	0

Example 1: Assigning parameters to the FC6 call

```
CALL    FC6
        Formal parameter   Actual parameter
        NO OF TOOL        := MW100
        TIME OUT          := MW110
        FOUND              := Q 0.1
        ERROR             := Q 100.0
```

Example 2: Calling an SFC without parameters

STL	Explanation
CALL SFC43	//Call SFC43 to re-trigger watchdog timer (no parameters).

Example 3: Calling FB99 with instance data block DB1

```
CALL    | FB99,DB1
        Formal parameter   Actual parameter
        MAX_RPM            := #RPM1_MAX
        MIN_RPM            := #RPM1
        MAX_POWER          := #POWER1
        MAX_TEMP           := #TEMP1
```

Example 4: Calling FB99 with instance data block DB2

```
CALL    FB99,DB2
        Formal parameter   Actual parameter
        MAX_RPM            := #RPM2_MAX
        MIN_RPM            := #RPM2
        MAX_POWER          := #POWER2
        MAX_TEMP           := #TEMP2
```

Note

Every FB or SFB CALL must have an instance data block. In the example above, the blocks DB1 and DB2 must already exist before the call.

10.6 Call FB

Format

CALL FB n1, DB n1

Description

This instruction is intended to call user-defined function blocks (FBs). The CALL instruction calls the function block you entered as address, independent of the RLO or other conditions. If you call a function block with CALL, you must provide it with an instance data block. After processing the called block, processing continues with the program for the calling block. The address for the logic block can be specified absolutely or symbolically.

Passing parameters (incremental edit mode)

The calling block can exchange parameters with the called block via the variable list. The variable list is extended automatically in your Statement List program when you enter a valid CALL instruction.

If you call a function block and the variable declaration table of the called block has IN, OUT, and IN_OUT declarations, these variables are added in the program for the calling block as a list of formal parameters.

When calling the function block, you only need to specify the actual parameters that must be changed from the previous call because the actual parameters are saved in the instance data block after the function block is processed. If the actual parameter is a data block, the complete, absolute address must be specified, for example DB1, DBW2.

The IN parameters can be specified as constants or as absolute or symbolic addresses. The OUT and IN_OUT parameters must be specified as absolute or symbolic addresses. You must ensure that all addresses and constants are compatible with the data types to be transferred.

CALL saves the return address (selector and relative address), the selectors of the two open data blocks, and the MA bit in the B (block) stack. In addition, CALL deactivates the MCR dependency, and then creates the local data area of the block to be called.

Status word

	BR	CC 1	CC 0	OV	OS	OR	STA	RLO	/FC
writes:	-	-	-	-	0	0	1	-	0

Example 1: FB99 call with instance data block DB1

```
CALL    FB99,DB1
        Formal parameter   Actual parameter
MAX_RPM := #RPM1_MAX
MIN_RPM := #RPM1
MAX_POWER := #POWER1
MAX_TEMP := #TEMP1
```

Example 2: FB99 call with instance data block DB2

```
CALL    FB99,DB2
        Formal parameter   Actual parameter
MAX_RPM := #RPM2_MAX
MIN_RPM := #RPM2
MAX_POWER := #POWER2
MAX_TEMP := #TEMP2
```

Note

Every function block CALL must have an instance data block. In the example above, the blocks DB1 and DB2 must already exist before the call.

10.7 Call FC

Format

CALL FC n

Note

If you are working in the STL Editor, the reference (n) must relate to existing valid blocks. You must also define the symbolic names prior to use.

Description

This instruction is intended to call functions (FCs). The CALL instruction calls the FC that you entered as address, independent of the RLO or other conditions. After processing the called block, processing continues with the program for the calling block. The address for the logic block can be specified absolutely or symbolically.

Passing parameters (incremental edit mode)

The calling block can exchange parameters with the called block via the variable list. The variable list is extended automatically in your Statement List program when you enter a valid CALL instruction.

If you call a function and the variable declaration table of the called block has IN, OUT, and IN_OUT declarations, these variables are added in the program for the calling block as a list of formal parameters.

When calling the function, you must assign actual parameters in the calling logic block to the formal parameters.

The IN parameters can be specified as constants or as absolute or symbolic addresses. The OUT and IN_OUT parameters must be specified as absolute or symbolic addresses. You must ensure that all addresses and constants are compatible with the data types to be transferred.

CALL saves the return address (selector and relative address), the selectors of the two open data blocks, and the MA bit in the B (block) stack. In addition, CALL deactivates the MCR dependency, and then creates the local data area of the block to be called.

Status word

	BR	CC 1	CC 0	OV	OS	OR	STA	RLO	/FC
writes:	-	-	-	-	0	0	1	-	0

Example: Assigning parameters to the FC6 call

```
CALL    FC6
        Formal parameter   Actual parameter
NO OF TOOL      := MW100
TIME OUT       := MW110
FOUND          := Q0.1
ERROR          := Q100.0
```

10.8 Call SFB

Format

CALL SFB n1, DB n2

Description

This instruction is intended to call the standard function blocks (SFBs) supplied by Siemens. The CALL instruction calls the SFB that you entered as address, independent of the RLO or other conditions. If you call a system function block with CALL, you must provide it with an instance data block. After processing the called block, processing continues with the program for the calling block. The address for the logic block can be specified absolutely or symbolically.

Passing parameters (incremental edit mode)

The calling block can exchange parameters with the called block via the variable list. The variable list is extended automatically in your Statement List program when you enter a valid CALL instruction.

If you call a system function block and the variable declaration table of the called block has IN, OUT, and IN_OUT declarations, these variables are added in the program for the calling block as a list of formal parameters.

When calling the system function block, you only need to specify the actual parameters that must be changed from the previous call because the actual parameters are saved in the instance data block after the system function block is processed. If the actual parameter is a data block, the complete, absolute address must be specified, for example DB1, DBW2.

The IN parameters can be specified as constants or as absolute or symbolic addresses. The OUT and IN_OUT parameters must be specified as absolute or symbolic addresses. You must ensure that all addresses and constants are compatible with the data types to be transferred.

CALL saves the return address (selector and relative address), the selectors of the two open data blocks, and the MA bit in the B (block) stack. In addition, CALL deactivates the MCR dependency, and then creates the local data area of the block to be called.

Status word

	BR	CC 1	CC 0	OV	OS	OR	STA	RLO	/FC
writes:	-	-	-	-	0	0	1	-	0

Example

```
CALL    SFB4, DB4
        Formal parameter   Actual parameter
IN:     I0.1
PT:     T#20s
Q:      M0.0
ET:     MW10
```

Note

Every system function block CALL must have an instance data block. In the example above, the blocks SFB4 and DB4 must already exist before the call.

10.9 Call SFC

Format

CALL SFC n

Note

If you are working in the STL Editor, the reference (n) must relate to existing valid blocks. You must also define the symbolic names prior to use.

Description

This instruction is intended to call the standard functions (SFCs) supplied by Siemens. The CALL instruction calls the SFC that you entered as address, independent of the RLO or other conditions. After processing the called block, processing continues with the program for the calling block. The address for the logic block can be specified absolutely or symbolically.

Passing parameters (incremental edit mode)

The calling block can exchange parameters with the called block via the variable list. The variable list is extended automatically in your Statement List program when you enter a valid CALL instruction.

If you call a system function and the variable declaration table of the called block has IN, OUT, and IN_OUT declarations, these variables are added in the program for the calling block as a list of formal parameters.

When calling the system function, you must assign actual parameters in the calling logic block to the formal parameters.

The IN parameters can be specified as constants or as absolute or symbolic addresses. The OUT and IN_OUT parameters must be specified as absolute or symbolic addresses. You must ensure that all addresses and constants are compatible with the data types to be transferred.

CALL saves the return address (selector and relative address), the selectors of the two open data blocks, and the MA bit in the B (block) stack. In addition, CALL deactivates the MCR dependency, and then creates the local data area of the block to be called.

Status word

	BR	CC 1	CC 0	OV	OS	OR	STA	RLO	/FC
writes:	-	-	-	-	0	0	1	-	0

Example: Calling an SFC without parameters

STL	Explanation
CALL SFC43	//Call SFC43 to re-trigger watchdog timer (no parameters).

10.10 Call Multiple Instance

Format

CALL # variable name

Description

A multiple instance is created by declaring a static variable with the data type of a function block. Only multiple instances that have already been declared are included in the program element catalog.

Status word

	BR	CC 1	CC 0	OV	OS	OR	STA	RLO	/FC
writes:	-	-	-	-	0	0	x	x	x

10.11 Call Block from a Library

The libraries available in the SIMATIC Manager can be used here to select a block that

- Is integrated in your CPU operating system ("Standard Library")
- You saved in a library in order to use it again.

10.12 CC Conditional Call

Format

CC <logic block identifier>

Description

CC <logic block identifier> (conditional block call) calls a logic block if RLO=1. CC is used to call logic blocks of the FC or FB type without parameters. CC is used in the same way as the **CALL** instruction except that you cannot transfer parameters with the calling program. The instruction saves the return address (selector and relative address), the selectors of the two current data blocks, as well as the MA bit into the B (block) stack, deactivates the MCR dependency, creates the local data area of the block to be called, and begins executing the called code. The address for the logic block can be specified absolutely or symbolically.

Status word

	BR	CC 1	CC 0	OV	OS	OR	STA	RLO	/FC
writes:	-	-	-	-	0	0	1	1	0

Example

STL	Explanation
A I 2.0	//Check signal state at input I 2.0.
CC FC6	//Call function FC6 if I 2.0 is "1".
A M 3.0	//Executed upon return from called function (I 2.0 = 1) or directly after A I 2.0 statement if I 2.0 = 0.

Note

If the **CALL** instruction calls a function block (FB) or a system function block (SFB), an instance data block (DB no.) must be specified in the statement. For a call with the **CC** instruction, you cannot assign a data block to the address in the statement.

Depending on the network you are working with, the Program Editor either generates the **UC** instruction or the **CC** instruction during conversion from the Ladder Logic programming language to the Statement List programming language. You should attempt to use the **CALL** instruction instead to avoid errors occurring in your programs.

10.13 UC Unconditional Call

Format

UC <logic block identifier>

Description

UC <logic block identifier> (unconditional block call) calls a logic block of the FC or SFC type. UC is like the CALL instruction, except that you cannot transfer parameters with the called block. The instruction saves the return address (selector and relative address) selectors of the two current data blocks, as well as the MA bit into the B (block) stack, deactivates the MCR dependency, creates the local data area of the block to be called, and begins executing the called code.

Status word

	BR	CC 1	CC 0	OV	OS	OR	STA	RLO	/FC
writes:	-	-	-	-	0	0	1	-	0

Example 1

STL	Explanation
UC FC6	//Call function FC6 (without parameters).

Example 2

STL	Explanation
UC SFC43	//Call system function SFC43 (without parameters).

Note

When the **CALL** instruction is used for a function block (FB) or system function block (SFB) an instance data block (DB no.) is expressed explicitly in the instruction. For a call made with the **UC** instruction, you cannot associate a data block in the UC address

Depending on the network you are working with, the Program Editor either generates the **UC** instruction or the **CC** instruction during conversion from the Ladder Logic programming language to the Statement List programming language. You should attempt to use the **CALL** instruction instead to avoid errors occurring in your programs.

10.14 MCR (Master Control Relay)

Important Notes on Using MCR Functions



Warning

To prevent personal injury or property damage, never use the MCR to replace a hard-wired mechanical master control relay for an emergency stop function.

Description

The Master Control Relay (MCR) is a relay ladder logic master switch for energizing and de-energizing power flow. Instructions triggered by the following bit logic and transfer instructions are dependent on the MCR:

- = <bit>
- S <bit>
- R <bit>
- T <byte>, T <word>, T <double word>

The **T** instruction, used with byte, word, and double word, writes a 0 to the memory if the MCR is 0. The **S** and **R** instructions leave the existing value unchanged. The instruction = writes "0" in the addressed bit.

Instructions dependent on MCR and their reactions to the signal state of the MCR

Signal State of MCR	= <bit>	S <bit>, R <bit>	T <byte>, T <word> T <double word>
0 ("OFF")	Writes 0. (Imitates a relay that falls to its quiet state when voltage is removed.)	Does not write. (Imitates a relay that remains in its current state when voltage is removed.)	Writes 0. (Imitates a component that produces a value of 0 when voltage is removed.)
1 ("ON")	Normal processing	Normal processing	Normal processing

MCR(- Begin MCR Area,)MCR - End MCR Area

The MCR is controlled by a stack one bit wide and eight bits deep. The MCR is energized as long as all eight entries are equal to 1. The MCR(instruction copies the RLO bit into the MCR stack. The)MCR instruction removes the last entry from the stack and sets the vacated position to 1. MCR(and)MCR instructions must always be used in pairs. A fault, that is, if there are more than eight consecutive MCR(instructions or an attempt is made to execute an)MCR instruction when the MCR stack is empty, triggers the MCRF error message.

MCRA - Activate MCR Area, MCRD - Deactivate MCR Area

MCRA and MCRD must always be used in pairs. Instructions programmed between MCRA and MCRD are dependent on the state of the MCR bit. The instructions that are programmed outside a MCRA-MCRD sequence are not dependent on the MCR bit state.

You must program the MCR dependency of functions (FCs) and function blocks (FBs) in the blocks themselves by using the MCRA instruction in the called block.

10.15 Important Notes on Using MCR Functions



Take care with blocks in which the Master Control Relay was activated with MCRA

- If the MCR is deactivated, the value 0 is written by all assignments (T, =) in program segments between **MCR(** and **)MCR**.
- The MCR is deactivated if the RLO was = 0 before an **MCR(** instruction.



Danger: PLC in STOP or undefined runtime characteristics!

The compiler also uses write access to local data behind the temporary variables defined in VAR_TEMP for calculating addresses. This means the following command sequences will set the PLC to STOP or lead to undefined runtime characteristics:

Formal parameter access

- Access to components of complex FC parameters of the type STRUCT, UDT, ARRAY, STRING
- Access to components of complex FB parameters of the type STRUCT, UDT, ARRAY, STRING from the IN_OUT area in a block with multiple instance capability (version 2 block).
- Access to parameters of a function block with multiple instance capability (version 2 block) if its address is greater than 8180.0.
- Access in a function block with multiple instance capability (version 2 block) to a parameter of the type BLOCK_DB opens DB0. Any subsequent data access sets the CPU to STOP. T 0, C 0, FC0, or FB0 are also always used for TIMER, COUNTER, BLOCK_FC, and BLOCK_FB.

Parameter passing

- Calls in which parameters are passed.

LAD/FBD

- T branches and midline outputs in Ladder or FBD starting with RLO = 0.

Remedy

Free the above commands from their dependence on the MCR:

1. Deactivate the Master Control Relay using the MCRD instruction before the statement or network in question.
2. Activate the Master Control Relay again using the MCRA instruction after the statement or network in question.

10.16 MCR(Save RLO in MCR Stack, Begin MCR

Important Notes on Using MCR Functions

Format

MCR(

Description

MCR((open an MCR area) saves the RLO on the MCR stack and opens a MCR area. The MCR area is the instructions between the instruction **MCR(** and the corresponding instruction **)MCR**. The instruction **MCR(** must always be used in combination with the instruction **)MCR**.

If RLO=1, then the MCR is "on." The MCR-dependent instructions within this MCR zone execute normally.

If RLO=0, then the MCR is "off."

The MCR-dependent instructions within this MCR zone execute according to the table below.

Instructions dependent on MCR Bit State

Signal State of MCR	= <bit>	S <bit>, R <bit>	T <byte>, T <word> T <double word>
0 ("OFF")	Writes 0. (Imitates a relay that falls to its quiet state when voltage is removed.)	Does not write. (Imitates a relay that remains in its current state when voltage is removed.)	Writes 0. (Imitates a component that produces a value of 0 when voltage is removed.)
1 ("ON")	Normal processing	Normal processing	Normal processing

The MCR(and)MCR instructions can be nested. The maximum nesting depth is eight instructions. The maximum number of possible stack entries is eight. Execution of MCR(with the stack full produces a MCR Stack Fault (MCRF).

Status word

	BR	CC 1	CC 0	OV	OS	OR	STA	RLO	/FC
writes:	-	-	-	-	-	0	1	-	0

Example

STL	Explanation
MCRA	//Activate MCR area.
A I 1.0	
MCR (//Save RLO in MCR stack, open MCR area. MCR = "on" when RLO=1 (I 1.0 ="1"); MCR = "off" when RLO=0 (I 1.0 ="0")
A I 4.0	
= Q 8.0	//If MCR = "off", then Q 8.0 is set to "0" regardless of I 4.0.
L MW20	
T QW10	//If MCR = "off", then "0" is transferred to QW10.
)MCR	//End MCR area.
MCRD	//Deactivate MCR area.
A I 1.1	
= Q 8.1	//These instructions are outside of the MCR area and are not dependent upon the MCR bit.

10.17)MCR End MCR

Important Notes on Using MCR Functions

Format

)MCR

Description

)MCR (end an MCR area) removes an entry from the MCR stack and ends an MCR area. The last MCR stack location is freed up and set to 1. The instruction MCR(must always be used in combination with the instruction)MCR. Execution of an)MCR instruction with the stack empty produces a MCR Stack Fault (MCRF).

Status word

	BR	CC 1	CC 0	OV	OS	OR	STA	RLO	/FC
writes:	-	-	-	-	-	0	1	-	0

Example

STL	Explanation
MCRA	//Activate MCR area.
A I 1.0	
MCR(//Save RLO in MCR stack; open MCR area. MCR = "on" when RLO=1 (I 1.0 ="1"); MCR = "off" when RLO=0 (I 1.0 ="0").
A I 4.0	
= Q 8.0	//If MCR = "off", then Q 8.0 is set to "0" regardless of I 4.0.
L MW20	
T QW10	//If MCR = "off", then "0" is transferred to QW10.
)MCR	//End MCR area.
MCRD	//Deactivate MCR area.
A I 1.1	
= Q 8.1	//These instructions are outside of the MCR area and are not dependent upon the MCR bit.

10.18 MCRA Activate MCR Area

Important Notes on Using MCR Functions

Format

MCRA

Description

MCRA (Master Control Relay Activation) energizes the MCR dependency for the instructions following after it. The instruction MCRA must always be used in combination with the instruction MCRD (Master Control Relay Deactivation). The instructions programmed between MCRA and MCRD are dependent upon the signal state of the MCR bit.

The instruction is executed without regard to, and without affecting, the status word bits.

Status word

	BR	CC 1	CC 0	OV	OS	OR	STA	RLO	/FC
writes:	-	-	-	-	-	-	-	-	-

Example

STL	Explanation
MCRA	//Activate MCR area.
A I 1.0	
MCR(//Save RLO in MCR stack, open MCR area. MCR = "on" when RLO=1 (I 1.0 ="1"); MCR = "off" when RLO=0 (I 1.0 ="0")
A I 4.0	
= Q 8.0	//If MCR = "off," then Q 8.0 is set to "0" regardless of I 4.0.
L MW20	
T QW10	//If MCR = "off," then "0" is transferred to QW10.
)MCR	//End MCR area.
MCRD	//Deactivate MCR area.
A I 1.1	
= Q 8.1	//These instructions are outside of the MCR area and are not dependent upon the MCR bit.

10.19 MCRD Deactivate MCR Area

Important Notes on Using MCR Functions

Format

MCRD

Description

MCRD (Master Control Relay Deactivation) de-energizes the MCR dependency for the instructions following after it. The instruction MCRA (Master Control Relay Activation) must always be used in combination with the instruction MCRD (Master Control Relay Deactivation). The instructions that are programmed between MCRA and MCRD are dependent upon the signal state of the MCR bit.

The instruction is executed without regard to, and without affecting, the status word bits.

Status word

	BR	CC 1	CC 0	OV	OS	OR	STA	RLO	/FC
writes:	-	-	-	-	-	-	-	-	-

Example

STL	Explanation
MCRA	//Activate MCR area.
A I 1.0	
MCR(//Save RLO in MCR stack, open MCR area. MCR = "on" when RLO=1 (I 1.0 ="1");
	MCR = "off" when RLO=0 (I 1.0 ="0")
A I 4.0	
= Q 8.0	//If MCR = "off", then Q 8.0 is set to "0" regardless of I 4.0.
L MW20	
T QW10	//If MCR = "off", then "0" is transferred to QW10.
)MCR	//End MCR area.
MCRD	//Deactivate MCR area.
A I 1.1	
= Q 8.1	//These instructions are outside of the MCR area and are not dependent upon the MCR bit.

11 Shift and Rotate Instructions

11.1 Shift Instructions

11.1.1 Overview of Shift Instructions

Description

You can use the Shift instructions to move the contents of the low word of accumulator 1 or the contents of the whole accumulator bit by bit to the left or the right (see also CPU Registers). Shifting by n bits to the left multiplies the contents of the accumulator by 2^n ; shifting by n bits to the right divides the contents of the accumulator by 2^n . For example, if you shift the binary equivalent of the decimal value 3 to the left by 3 bits, you end up with the binary equivalent of the decimal value 24 in the accumulator. If you shift the binary equivalent of the decimal value 16 to the right by 2 bits, you end up with the binary equivalent of the decimal value 4 in the accumulator.

The number that follows the shift instruction or a value in the low byte of the low word of accumulator 2 indicates the number of bits by which to shift. The bit places that are vacated by the shift instruction are either filled with zeros or with the signal state of the sign bit (a 0 stands for positive and a 1 stands for negative). The bit that is shifted last is loaded into the CC 1 bit of the status word. The CC 0 and OV bits of the status word are reset to 0. You can use jump instructions to evaluate the CC 1 bit. The shift operations are unconditional, that is, their execution does not depend on any special conditions. They do not affect the result of logic operation.

The following Shift instructions are available:

- SSI Shift Sign Integer (16-Bit)
- SSD Shift Sign Double Integer (32-Bit)
- SLW Shift Left Word (16-Bit)
- SRW Shift Right Word (16-Bit)
- SLD Shift Left Double Word (32-Bit)
- SRD Shift Right Double Word (32-Bit)

11.1.2 SSI Shift Sign Integer (16-Bit)

Formate

SSI
SSI <number>

Address	Data type	Description
<number>	integer, unsigned	number of bit positions to be shifted, range from 0 to 15

Description

SSI (shift right with sign integer) shifts only the contents of ACCU 1- L to the right bit by bit. The bit places that are vacated by the shift instruction are filled with the signal state of the sign bit (bit 15). The bit that is shifted out last is loaded into the status word bit CC 1. The number of bit positions to be shifted is specified either by the address <number> or by a value in ACCU 2-L-L.

SSI <number>: The number of shifts is specified by the address <number>. The permissible value range is from 0 to 15. The CC 0 and OV status word bits are reset to 0 if <number> is greater than zero. If <number> is equal to zero, the shift instruction is regarded as a **NOP** operation.

SSI: The number of shifts is specified by the value in ACCU 2- L- L. The possible value range is from 0 to 255. A shift number >16 always produces the same result (ACCU 1 = 16#0000, CC 1 = 0, or ACCU 1 = 16#FFFF, CC 1 = 1). If the shift number is greater than 0, the status word bits CC 0 and OV are reset to 0. If the shift number is zero, then the shift instruction is regarded as a **NOP** operation.

Status word

	BR	CC 1	CC 0	OV	OS	OR	STA	RLO	/FC
writes:	-	x	x	x	-	-	-	-	-

Examples

Contents	ACCU1-H				ACCU1-L			
	31 16	15 0
before execution of SSI 6	0101	1111	0110	0100	1001	1101	0011	1011
after execution of SSI 6	0101	1111	0110	0100	1111	1110	0111	0100

Example 1

STL		Explanation
L	MW4	//Load value into ACCU 1.
SRW	6	//Shift bits with sign in ACCU 1 six places to the right.
T	MW8	//Transfer result to MW8.

Example 2

STL		Explanation
L	+3	//Load value +3 into ACCU 1.
L	MW20	//Load contents of ACCU 1 into ACCU 2. Load value of MW20 into ACCU 1.
SRW		//Shift number is value of ACCU 2- L- L => Shift bits with sign in ACCU 1-L three places to the right; fill free places with state of sign bit.
JP	NEXT	//Jump to NEXT jump label if the bit shifted out last (CC 1) = 1.

11.1.3 SSD Shift Sign Double Integer (32-Bit)

Formate

SSD
SSD <number>

Address	Data type	Description
<number>	integer, unsigned	number of bit positions to be shifted, range from 0 to 32

Description

SSD (shift right with sign double integer) shifts the entire contents of ACCU 1 to the right bit by bit. The bit places that are vacated by the shift instruction are filled with the signal state of the sign bit. The bit that is shifted out last is loaded into the status word bit CC 1. The number of bit positions to be shifted is specified either by the address <number> or by a value in ACCU 2-L-L.

SSD <number>: The number of shifts is specified by the address <number>. The permissible value range is from 0 to 32. The CC 0 and OV status word bits are reset to 0 if <number> is greater than 0. If <number> is equal to 0, the shift instruction is regarded as a **NOP** operation.

SSD: The number of shifts is specified by the value in ACCU 2- L- L. The possible value range is from 0 to 255. A shift number > 32 always produces the same result (ACCU 1 = 32#00000000, CC 1 = 0 or ACCU 1 = 32#FFFFFFFF, CC 1 = 1). If the shift number is greater than 0, the status word bits CC 0 and OV are reset to 0. If the shift number is zero, then the shift instruction is regarded as an **NOP** operation.

Status word

	BR	CC 1	CC 0	OV	OS	OR	STA	RLO	/FC
writes:	-	x	x	x	-	-	-	-	-

Examples

Contents	ACCU1-H				ACCU1-L			
	31 16	15 0
before execution of SSD 7	1000	1111	0110	0100	0101	1101	0011	1011
after execution of SSD 7	1111	1111	0001	1110	1100	1000	1011	1010

Example 1

STL	Explanation	
L MD4	//Load value into ACCU 1.	
SSD 7	//Shift bits in ACCU 1 seven places to the right, according to the sign.	
T MD8	//Transfer result to MD8.	

Example 2

STL	Explanation	
L +3	//Load value +3 into ACCU 1.	
L MD20	//Load contents of ACCU 1 into ACCU 2. Load value of MD20 into ACCU 1.	
SSD	//Shift number is value of ACCU 2- L- L => Shift bits with sign in ACCU 1 three places to the right, fill free places with state of sign bit.	
JP NEXT	//Jump to NEXT jump label if the bit shifted out last (CC 1) = 1.	

11.1.4 SLW Shift Left Word (16-Bit)

Formate

SLW
SLW <number>

Address	Data type	Description
<number>	integer, unsigned	number of bit positions to be shifted, range from 0 to 15

Description

SLW (shift left word) shifts only the contents of ACCU 1- L to the left bit by bit. The bit places that are vacated by the shift instruction are filled with zeros. The bit that is shifted out last is loaded into the status word bit CC 1. The number of bit positions to be shifted is specified either by the address <number> or by a value in ACCU 2-L-L.

SLW <number>: The number of shifts is specified by the address <number>. The permissible value range is from 0 to 15. The status word bits CC 0 and OV are reset to zero if <number> is greater than zero. If <number> is equal to zero, then the shift instruction is regarded as a **NOP** operation.

SLW: The number of shifts is specified by the value in ACCU 2- L- L. The possible value range is from 0 to 255. A shift number >16 always produces the same result: ACCU 1- L = 0, CC 1 = 0, CC 0 = 0, and OV = 0. If 0 < shift number <= 16, the status word bits CC 0 and OV are reset to 0. If the shift number is zero, then the shift instruction is regarded as a **NOP** operation.

Status word

	BR	CC 1	CC 0	OV	OS	OR	STA	RLO	/FC
writes:	-	X	X	X	-	-	-	-	-

Examples

Contents	ACCU1-H				ACCU1-L			
Bit	31 16	15 0
before execution of SLW 5	0101	1111	0110	0100	0101	1101	0011	1011
after execution of SLW 5	0101	1111	0110	0100	1010	0111	0110	0000

Example 1

STL	Explanation	
L MW4	//Load value into ACCU 1.	
SLW 5	//Shift the bits in ACCU 1 five places to the left.	
T MW8	//Transfer result to MW8.	

Example 2

STL	Explanation	
L +3	//Load value +3 into ACCU 1.	
L MW20	//Load contents of ACCU 1 into ACCU 2. Load value of MW20 into ACCU 1.	
SLW	//Shift number is value of ACCU 2- L- L => Shift bits in ACCU 1-L three places to the left.	
JP NEXT	//Jump to NEXT jump label if the bit shifted out last (CC 1) = 1.	

11.1.5 SRW Shift Right Word (16-Bit)

Formate

SRW
SRW <number>

Address	Data type	Description
<number>	integer, unsigned	number of bit positions to be shifted, range from 0 to 15

Description

SRW (shift right word) shifts only the contents of ACCU 1- L to the right bit by bit. The bit places that are vacated by the shift instruction are filled with zeros. The bit that is shifted out last is loaded into the status bit CC 1. The number of bit positions to be shifted is specified either by the address <number> or by a value in ACCU 2-L-L.

SRW <number>: The number of shifts is specified by the address <number>. The permissible value range is from 0 to 15. The status word bits CC 0 and OV are reset to 0 if <number> is greater than zero. If <number> is equal to 0, the shift instruction is regarded as a **NOP** operation.

SRW: The number of shifts is specified by the value in ACCU 2- L- L. The possible value range is from 0 to 255. A shift number >16 always produces the same result: ACCU 1- L = 0, CC 1 = 0, CC 0 = 0, and OV = 0. If 0 < shift number <= 16, the status word bits CC 0 and OV are reset to 0. If the shift number is zero, then the shift instruction is regarded as a **NOP** operation.

Status word

	BR	CC 1	CC 0	OV	OS	OR	STA	RLO	/FC
writes:	-	X	X	X	-	-	-	-	-

Examples

Contents	ACCU1-H				ACCU1-L			
	31 16	15 0
before execution of SRW 6	0101	1111	0110	0100	0101	1101	0011	1011
after execution of SRW 6	0101	1111	0110	0100	0000	0001	0111	0100

Example 1

STL	Explanation	
L MW4	//Load value into ACCU 1.	
SRW 6	//Shift bits in ACCU 1-L six places to the right.	
T MW8	//Transfer result to MW8.	

Example 2

STL	Explanation	
L +3	//Load value +3 into ACCU 1.	
L MW20	//Load contents of ACCU 1 into ACCU 2. Load value of MW20 into ACCU 1.	
SRW	//Shift number is value of ACCU 2- L- L => Shift bits in ACCU 1-L three places to the right.	
SPP NEXT	//Jump to NEXT jump label if the bit shifted out last (CC 1) = 1.	

11.1.6 SLD Shift Left Double Word (32-Bit)

Format

SLD
SLD <number>

Address	Data type	Description
<number>	integer, unsigned	number of bit positions to be shifted, range from 0 to 32

Description

SLD (shift left double word) shifts the entire contents of ACCU 1 to the left bit by bit. The bit places that are vacated by the shift instruction are filled with zeros. The bit that is shifted out last is loaded into the status word bit CC 1. The number of bit positions to be shifted is specified either by the address <number> or by a value in ACCU 2-L-L.

SLD <number>: The number of shifts is specified by the address <number>. The permissible value range is from 0 to 32. The status word bits CC 0 and OV are reset to zero if <number> is greater than zero. If <number> is equal to zero, then the shift instruction is regarded as a **NOP** operation.

SLD: The number of shifts is specified by the value in ACCU 2- L- L. The possible value range is from 0 to 255. A shift number >32 always produces the same result: ACCU 1 = 0, CC 1 = 0, CC 0 = 0, and OV = 0. If 0 < shift number <= 32, the status word bits CC 0 and OV are reset to 0. If the shift number is zero, then the shift instruction is regarded as a **NOP** operation.

Status word

	BR	CC 1	CC 0	OV	OS	OR	STA	RLO	/FC
writes:	-	x	x	x	-	-	-	-	-

Examples

Contents	ACCU1-H				ACCU1-L			
	31 16	15 0
before execution of SLD 5	0101	1111	0110	0100	0101	1101	0011	1011
after execution of SLD 5	1110	1100	1000	1011	1010	0111	0110	0000

Example 1

STL	Explanation	
L MD4	//Load value into ACCU 1.	
SLD 5	//Shift bits in ACCU 1 five places to the left.	
T MD8	//Transfer result to MD8.	

Example 2

STL	Explanation	
L +3	//Load value +3 into ACCU 1.	
L MD20	//Load the contents of ACCU 1 into ACCU 2. Load value of MD20 into ACCU 1.	
SLD	//Shift number is value of ACCU 2- L- L => Shift bits in ACCU 1 three places to the left.	
JP NEXT	//Jump to NEXT jump label if the bit shifted out last (CC 1) = 1.	

11.1.7 SRD Shift Right Double Word (32-Bit)

Formate

SRD
SRD <number>

Address	Data type	Description
<number>	integer, unsigned	number of bit positions to be shifted, range from 0 to 32

Description

SRD (shift right double word) shifts the entire contents of ACCU 1 to the right bit by bit. The bit places that are vacated by the shift instruction are filled with zeros. The bit that is shifted out last is loaded into the status word bit CC 1. The number of bit positions to be shifted is specified either by the address <number> or by a value in ACCU 2-L-L.

SRD <number>: The number of shifts is specified by the address <number>. The permissible value range is from 0 to 32. The status word bits CC 0 and OV are reset to 0 if <number> is greater than zero. If <number> is equal to 0, the shift instruction is regarded as a **NOP** operation.

SRD: The number of shifts is specified by the value in ACCU 2- L- L. The possible value range is from 0 to 255. A shift number >32 always produces the same result: ACCU 1 = 0, CC 1 = 0, CC 0 = 0, and OV = 0. If 0 < shift number <= 32, the status word bits CC 0 and OV are reset to 0. If the shift number is zero, then the shift instruction is regarded as a **NOP** operation.

Status word

	BR	CC 1	CC 0	OV	OS	OR	STA	RLO	/FC
writes:	-	X	X	X	-	-	-	-	-

Examples

Contents	ACCU1-H				ACCU1-L			
	31 16	15 0
before execution of SRD 7	0101	1111	0110	0100	0101	1101	0011	1011
after execution of SRD 7	0000	0000	1011	1110	1100	1000	1011	1010

Example 1

STL	Explanation	
L MD4	//Load value into ACCU 1.	
SRD 7	//Shift bits in ACCU 1 seven places to the right.	
T MD8	//Transfer result to MD8.	

Example 2

STL	Explanation	
L +3	//Load value +3 into ACCU 1.	
L MD20	//Load contents of ACCU 1 into ACCU 2. Load value of MD20 into ACCU 1.	
SRD	//Shift number is value of ACCU 2- L- L => Shift bits in ACCU 1 three places to the right.	
JP NEXT	//Jump to NEXT jump label if the bit shifted out last (CC 1) =1.	

11.2 Rotate Instructions

11.2.1 Overview of Rotate Instructions

Description

You can use the Rotate instructions to rotate the entire contents of accumulator 1 bit by bit to the left or to the right (see also CPU Registers). The Rotate instructions trigger functions that are similar to the shift functions described in Section 14.1. However, the vacated bit places are filled with the signal states of the bits that are shifted out of the accumulator.

The number that follows the rotate instruction or a value in the low byte of the low word of accumulator 2 indicates the number of bits by which to rotate. Depending on the instruction, rotation takes place via the CC 1 bit of the status word. The CC 0 bit of the status word is reset to 0.

The following Rotate instructions are available:

- RLD Rotate Left Double Word (32-Bit)
- RRD Rotate Right Double Word (32-Bit)
- RLDA Rotate ACCU 1 Left via CC 1 (32-Bit)
- RRDA Rotate ACCU 1 Right via CC 1 (32-Bit)

11.2.2 RLD Rotate Left Double Word (32-Bit)

Format

RLD
RLD <number>

Address	Data type	Description
<number>	integer, unsigned	number of bit positions to be rotated, range from 0 to 32

Description

RLD (rotate left double word) rotates the entire contents of ACCU1 to the left bit by bit. The bit places that are vacated by the rotate instruction are filled with the signal states of the bits that are shifted out of ACCU 1. The bit that is rotated last is loaded into the status bit CC 1. The number of bit positions to be rotated is specified either by the address <number> or by a value in ACCU 2-L-L.

RLD <number>: The number of rotations is specified by the address <number>. The permissible value range is from 0 to 32. The status word bits CC 0 and OV are reset to 0 if <number> is greater than zero. If <number> is equal to 0, the rotate instruction is regarded as a **NOP** operation.

RLD: The number of rotations is specified by the value in ACCU 2- L- L. The possible value range is from 0 to 255. The status word bits CC 0 and OV are reset to 0 if the contents of ACCU 2-L-L are greater than zero. If the rotation number is zero, then the rotate instruction is regarded as an **NOP** operation.

Status word

	BR	CC 1	CC 0	OV	OS	OR	STA	RLO	/FC
writes:	-	x	x	x	-	-	-	-	-

Examples

Contents	ACCU1-H				ACCU1-L			
	31 16	15 0
before execution of RLD 4	0101	1111	0110	0100	0101	1101	0011	1011
after execution of RLD 4	1111	0110	0100	0101	1101	0011	1011	0101

Example 1

STL	Explanation	
L MD2	//Load value into ACCU 1.	
RLD 4	//Rotate bits in ACCU 1 four places to the left.	
T MD8	//Transfer result to MD8.	

Example 2

STL	Explanation	
L +3	//Load value +3 into ACCU 1.	
L MD20	//Load contents of ACCU 1 into ACCU 2. Load value of MD20 into ACCU 1.	
RLD	//Rotation number is value of ACCU 2- L- L => Rotate bits in ACCU 1 three places to the left.	
JP NEXT	//Jump to NEXT jump label if the bit rotated out last (CC 1) = 1.	

11.2.3 RRD Rotate Right Double Word (32-Bit)

Format

RRD
RRD <number>

Address	Data type	Description
<number>	integer, unsigned	number of bit positions to be rotated, range from 0 to 32

Description

RRD (rotate right double word) rotates the entire contents of ACCU 1 to the right bit by bit. The bit places that are vacated by the rotate instruction are filled with the signal states of the bits that are shifted out of ACCU 1. The bit that is rotated last is loaded into the status bit CC 1. The number of bit positions to be rotated is specified either by the address <number> or by a value in ACCU 2-L-L.

RRD <number>: The number of rotations is specified by the address <number>. The permissible value range is from 0 to 32. The status word bits CC 0 and OV are reset to 0 if <number> is greater than zero. If <number> equals zero, then the rotate instruction is regarded as a **NOP** operation.

RRD: The number of rotations is specified by the value in ACCU 2- L- L. The possible value range is from 0 to 255. The status word bits are reset to 0 if the contents of ACCU 2-L-L are greater than zero.

Status word

	BR	CC 1	CC 0	OV	OS	OR	STA	RLO	/FC
writes:	-	X	X	X	-	-	-	-	-

Examples

Contents	ACCU1-H				ACCU1-L			
	31 16	15 0
before execution of RRD 4	0101	1111	0110	0100	0101	1101	0011	1011
after execution of RRD 4	1011	0101	1111	0110	0100	0101	1101	0011

Example 1

STL	Explanation	
L MD2	//Load value into ACCU 1.	
RRD 4	//Rotate bits in ACCU 1 four places to the right.	
T MD8	//Transfer result to MD8.	

Example 2

STL	Explanation	
L +3	//Load value +3 into ACCU 1.	
L MD20	//Load contents of ACCU 1 into ACCU 2. Load value of MD20 into ACCU 1.	
RRD	//Rotation number is value of ACCU 2- L- L => Rotate bits in ACCU 1 three places to the right.	
JP NEXT	//Jump to NEXT jump label if the bit rotated out last (CC 1) = 1.	

11.2.4 RLDA Rotate ACCU 1 Left via CC 1 (32-Bit)

Format

RLDA

Description

RLDA (rotate left double word via CC 1) rotates the entire contents of ACCU 1 to the left by one bit position via CC 1. The status word bits CC 0 and OV are reset to 0.

Status word

	BR	CC 1	CC 0	OV	OS	OR	STA	RLO	/FC
writes:	-	x	0	0	-	-	-	-	-

Examples

Contents	CC 1	ACCU1-H				ACCU1-L			
Bit		31... 16	15... 0
before execution of RLDA	X	0101	1111	0110	0100	0101	1101	0011	1011
after execution of RLDA	0	1011	1110	1100	1000	1011	1010	0111	011 X
	(X = 0 or 1, previous signal state of CC 1)								

STL	Explanation
L MD2	//Load value of MD2 into ACCU 1.
RLDA	//Rotate bits in ACCU 1 one place to the left via CC 1.
JP NEXT	//Jump to NEXT jump label if the bit rotated out last (CC 1) = 1.

11.2.5 RRDA Rotate ACCU 1 Right via CC 1 (32-Bit)

Format

RRDA

Description

RRDA (rotate right double word via CC 1) rotates the entire contents of ACCU 1 to the right by one bit position. The status word bits CC 0 and OV are reset to 0.

Status word

	BR	CC 1	CC 0	OV	OS	OR	STA	RLO	/FC
writes:	-	x	0	0	-	-	-	-	-

Examples

Contents	CC 1	ACCU1-H				ACCU1-L			
Bit		31...16	15...0
before execution of RRDA	X	0101	1111	0110	0100	0101	1101	0011	1011
after execution of RRDA	1	X010	1111	1011	0010	0010	1110	1001	1101
	(X = 0 or 1, previous signal state of CC 1)								

STL	Explanation
L MD2	//Load value of MD2 into ACCU 1.
RRDA	//Rotate bits in ACCU 1 one place to the right via CC 1.
JP NEXT	//Jump to NEXT jump label if the bit rotated out last (CC 1) = 1.

12 Timer Instructions

12.1 Overview of Timer Instructions

Description

You can find information for setting and selecting the correct time under Location of a Timer in Memory and components of a Timer.

The following timer instructions are available:

- FR Enable Timer (Free)
- L Load Current Timer Value into ACCU 1 as Integer
- LC Load Current Timer Value into ACCU 1 as BCD
- R Reset Timer
- SD On-Delay Timer
- SE Extended Pulse Timer
- SF Off-Delay Timer
- SP Pulse Timer
- SS Retentive On-Delay Timer

12.2 Location of a Timer in Memory and Components of a Timer

Area in Memory

Timers have an area reserved for them in the memory of your CPU. This memory area reserves one 16-bit word for each timer address. The ladderlogic instruction set supports 256 timers. Please refer to your CPU's technical information to establish the number of timer words available.

The following functions have access to the timer memory area:

- Timer instructions
- Updating of timer words by means of clock timing. This function of your CPU in the RUN mode decrements a given time value by one unit at the interval designated by the time base until the time value is equal to zero.

Time Value

Bits 0 through 9 of the timer word contain the time value in binary code. The time value specifies a number of units. Time updating decrements the time value by one unit at an interval designated by the time base. Decrementing continues until the time value is equal to zero. You can load a time value into the low word of accumulator 1 in binary, hexadecimal, or binary coded decimal (BCD) format.

You can pre-load a time value using either of the following formats:

- **W#16#txyz**
 - Where t = the time base (that is, the time interval or resolution)
 - Where xyz = the time value in binary coded decimal format
- **S5T#aH_bM_cS_dMS**
 - Where H = hours, M = minutes, S = seconds, and MS = milliseconds; user variables are: a, b, c, d
 - The time base is selected automatically, and the value is rounded to the next lower number with that time base.

The maximum time value that you can enter is 9,990 seconds, or 2H_46M_30S.

Time Base

Bits 12 and 13 of the timer word contain the time base in binary code. The time base defines the interval at which the time value is decremented by one unit. The smallest time base is 10 ms; the largest is 10 s.

Time Base	Binary Code for the Time Base
10 ms	00
100 ms	01
1 s	10
10 s	11

Values that exceed 2h46m30s are not accepted. A value whose resolution is too high for the range limits (for example, 2h10ms) is truncated down to a valid resolution. The general format for S5TIME has limits to range and resolution as shown below:

Resolution	Range
0.01 second	10MS to 9S_990MS
0.1 second	100MS to 1M_39S_900MS
1 second	1S to 16M_39S
10 seconds	10S to 2H_46M_30S

Bit Configuration in ACCU 1

When a timer is started, the contents of ACCU1 are used as the time value. Bits 0 through 11 of the ACCU1-L hold the time value in binary coded decimal format (BCD format: each set of four bits contains the binary code for one decimal value). Bits 12 and 13 hold the time base in binary code.

The following figure shows the contents of ACCU1-L loaded with timer value 127 and a time base of 1 second:

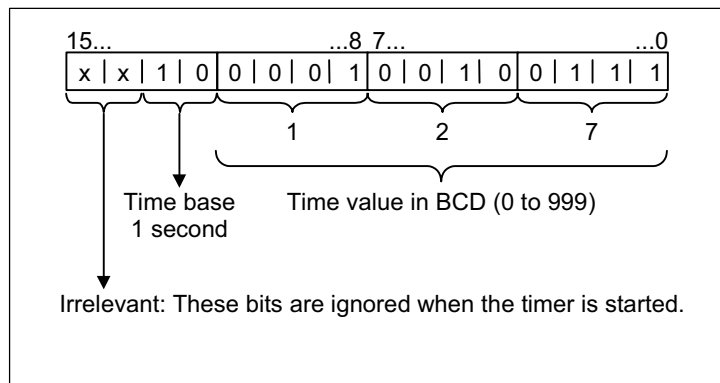

Choosing the right Timer

This overview is intended to help you choose the right timer for your timing job.

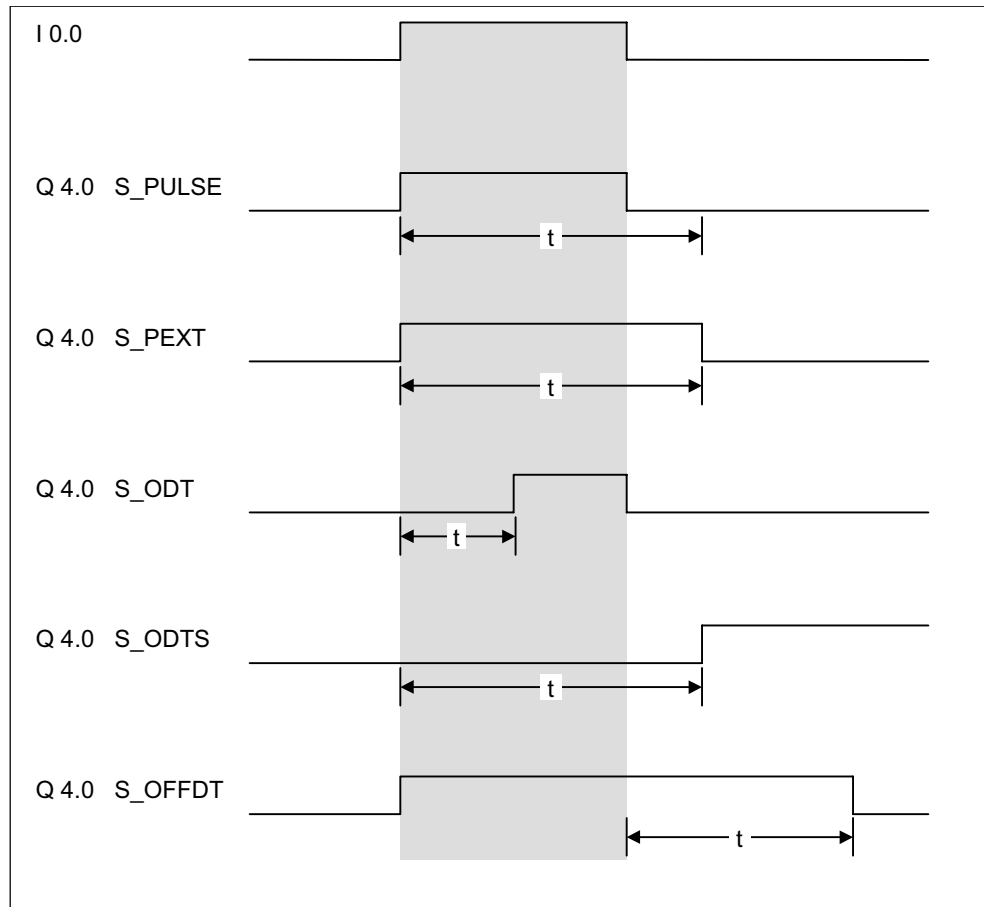

Timer	Description
S_PULSE Pulse timer	The maximum time that the output signal remains at 1 is the same as the programmed time value t. The output signal stays at 1 for a shorter period if the input signal changes to 0.
S_PEXT Extended pulse timer	The output signal remains at 1 for the programmed length of time, regardless of how long the input signal stays at 1.
S_ODT On-delay timer	The output signal changes to 1 only when the programmed time has elapsed and the input signal is still 1.
S_ODTS Retentive on-delay timer	The output signal changes from 0 to 1 only when the programmed time has elapsed, regardless of how long the input signal stays at 1.
S_OFFDT Off-delay timer	The output signal changes to 1 when the input signal changes to 1 or while the timer is running. The time is started when the input signal changes from 1 to 0.

12.3 FR Enable Timer (Free)

Format

FR <timer>

Address	Data type	Memory area	Description
<timer>	TIMER	T	Timer number, range depends on CPU

Description of instruction

When the RLO transitions from "0" to "1", **FR <timer>** clears the edge-detecting flag that is used for starting the addressed timer. A change in the RLO bit from 0 to 1 in front of an enable instruction (FR) enables a timer.

Timer enable is not required to start a timer, nor is it required for normal timer instruction. An enable is used only to re-trigger a running timer, that is, to restart a timer. The restarting is possible only when the start instruction continues to be processed with RLO = 1.

Status word

	BR	CC 1	CC 0	OV	OS	OR	STA	RLO	/FC
writes:	-	-	-	-	-	0	-	-	0

Example

STL	Explanation
A I 2.0	
FR T1	//Enable timer T1.
A I 2.1	
L S5T#10s	//Preset 10 seconds into ACCU 1.
SI T1	//Start timer T1 as a pulse timer.
A I 2.2	
R T1	//Reset timer T1.
A T1	//Check signal state of timer T1.
= Q 4.0	
L T1	//Load current time value of timer T1 as a binary number.
T MW10	

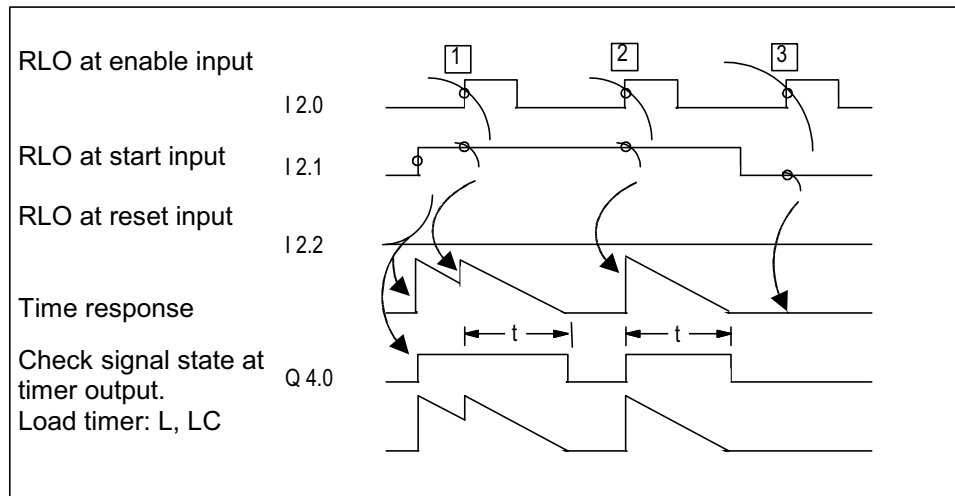

t = programmed time interval

- (1) A change in the RLO from 0 to 1 at the enable input while the timer is running completely restarts the timer. The programmed time is used as the current time for the restart. A change in the RLO from 1 to 0 at the enable input has no effect.
- (2) If the RLO changes from 0 to 1 at the enable input while the timer is not running and there is still an RLO of 1 at the start input, the timer will also be started as a pulse with the time programmed.
- (3) A change in the RLO from 0 to 1 at the enable input while there is still an RLO of 1 at the start input has no effect on the timer.

12.4 L Load Current Timer Value into ACCU 1 as Integer

Format

L <timer>

Address	Data type	Memory area	Description
<timer>	TIMER	T	Timer number, range depends on CPU

Description of instruction

L <timer> loads the current timer value from the addressed timer word without a time base as a binary integer into ACCU 1-L after the contents of ACCU 1 have been saved into ACCU 2.

Status word

	BR	CC 1	CC 0	OV	OS	OR	STA	RLO	/FC
writes:	-	-	-	-	-	-	-	-	-

Example

STL	Explanation
L T1	//Load ACCU 1-L with the current timer value of timer T1 in binary code.

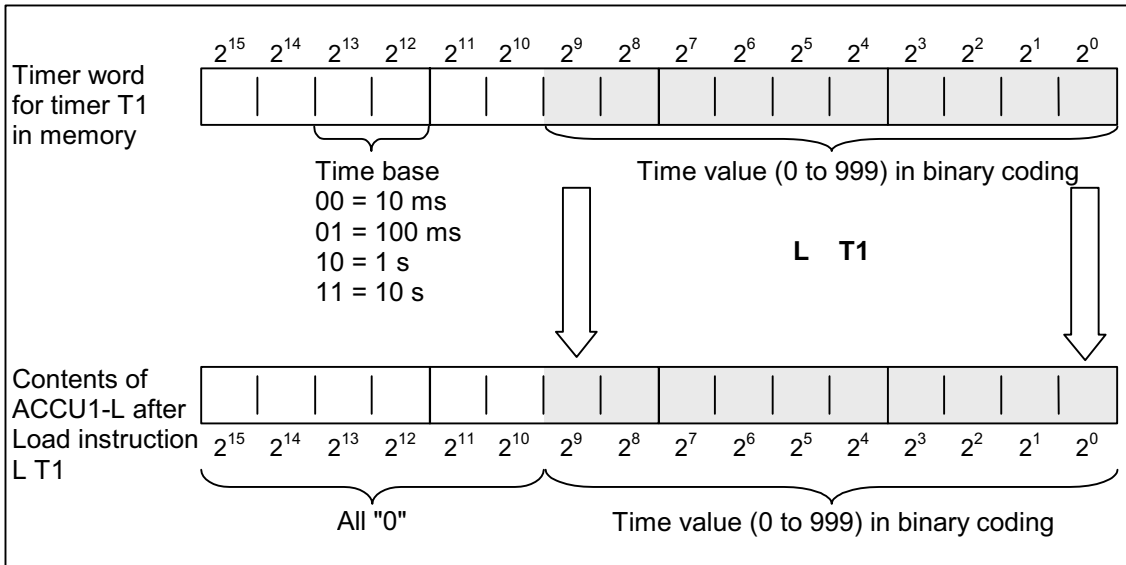

Note

L <timer> loads only the binary code of the current timer value into ACCU1-L, and not the time base. The time loaded is the initial value minus the time elapsed since the timer was started.

12.5 LC Load Current Timer Value into ACCU 1 as BCD

Format

LC <timer>

Address	Data type	Memory area	Description
<timer>	TIMER	T	Timer number, range depends on CPU

Description of instruction

LC <timer> loads the current timer value and time base from the addressed timer word as a Binary Coded Decimal (BCD) number into ACCU 1 after the content of ACCU 1 has been saved into ACCU 2.

Status word

	BR	CC 1	CC 0	OV	OS	OR	STA	RLO	/FC
writes:	-	-	-	-	-	-	-	-	-

Example

STL	Explanation
LC T1	//Load ACCU 1-L with the time base and current timer value of timer T1 in binary coded decimal (BCD) format.

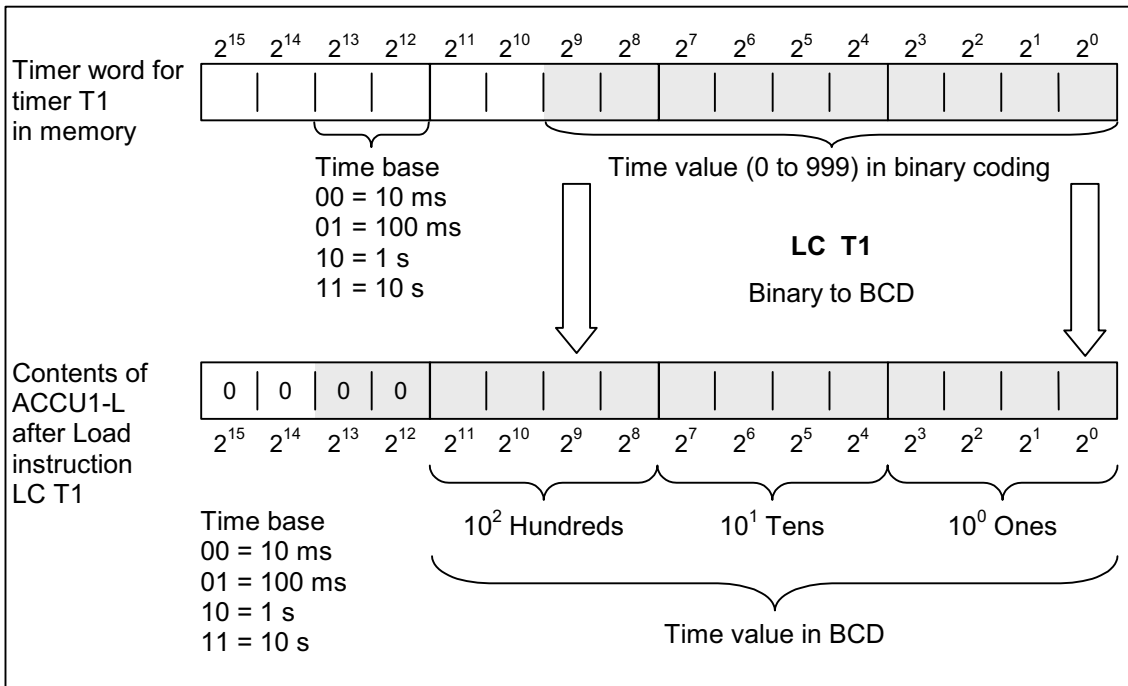

12.6 R Reset Timer

Format

R <timer>

Address	Data type	Memory area	Description
<timer>	TIMER	T	Timer number, range depends on CPU

Description of instruction

R <timer> stops the current timing function and clears the timer value and the time base of the addressed timer word if the RLO transitions from 0 to 1.

Status word

	BIE	A1	A0	OV	OS	OR	STA	VKE	/ER
writes:	-	-	-	-	-	0	-	-	0

Example

STL	Explanation
A I 2.1	
R T1	//Check the signal state of input I 2.1 If RLO transitioned from 0 = 1, then reset timer T1.

12.7 SP Pulse Timer

Format

SP <timer>

Address	Data type	Memory area	Description
<timer>	TIMER	T	Timer number, range depends on CPU

Description of instruction

SP <timer> starts the addressed timer when the RLO transitions from "0" to "1". The programmed time elapses as long as RLO = 1. The timer is stopped if RLO transitions to "0" before the programmed time interval has expired. This timer start command expects the time value and the time base to be stored as a BCD number in ACCU 1-L.

See also Location of a Timer in Memory and Components of a Timer.

Status word

	BIE	A1	A0	OV	OS	OR	STA	VKE	/ER
writes:	-	-	-	-	-	0	-	-	0

Example

STL	Explanation
A I 2.0	
FR T1	//Enable timer T1.
A I 2.1	
L S5T#10s	//Preset 10 seconds into ACCU 1.
SP T1	//Start timer T1 as a pulse timer.
A I 2.2	
R T1	//Reset timer T1.
A T1	//Check signal state of timer T1.
= Q 4.0	
L T1	//Load current time value of timer T1 as binary.
T MW10	
LC T1	//Load current time value of timer T1 as BCD.
T MW12	

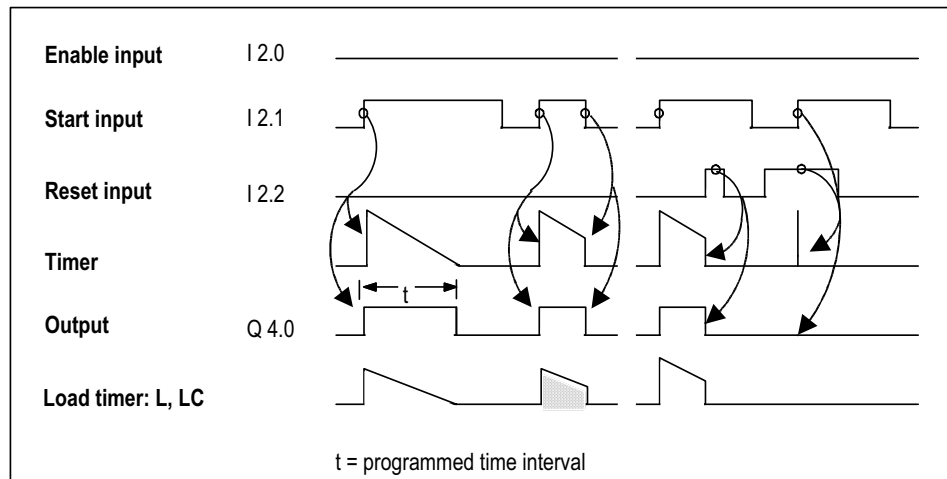

12.8 SE Extended Pulse Timer

Format

SE <timer>

Address	Data type	Memory area	Description
<timer>	TIMER	T	Timer number, range depends on CPU

Description of instruction

SE <timer> starts the addressed timer when the RLO transitions from "0" to "1". The programmed time interval elapses, even if the RLO transitions to "0" in the meantime. The programmed time interval is started again if RLO transitions from "0" to "1" before the programmed time has expired. This timer start command expects the time value and the time base to be stored as a BCD number in ACCU 1-L.

See also Location of a Timer in Memory and Components of a Timer.

Status word

	BIE	A1	A0	OV	OS	OR	STA	VKE	/ER
writes:	-	-	-	-	-	0	-	-	0

Example

STL	Explanation
A I 2.0	
FR T1	//Enable timer T1.
A I 2.1	
L S5T#10s	//Preset 10 seconds into ACCU 1.
SE T1	//Start timer T1 as an extended pulse timer.
A I 2.2	
R T1	//Reset timer T1.
A T1	//Check signal state of timer T1.
= Q 4.0	
L T1	//Load current timer value of timer T1 as binary.
T MW10	
LC T1	//Load current timer value of timer T1 as BCD.
T MW12	

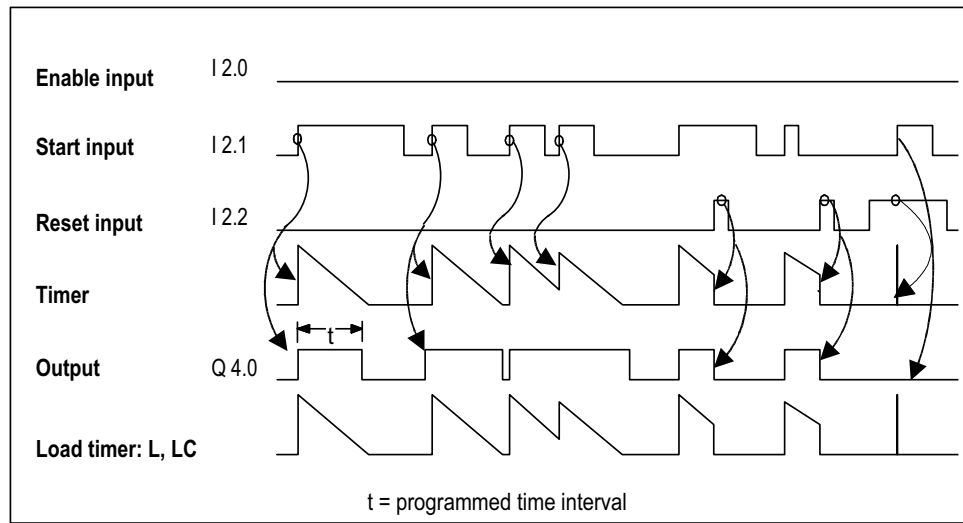

12.9 SD On-Delay Timer

Format

SD <timer>

Address	Data type	Memory area	Description
<timer>	TIMER	T	Timer number, range depends on CPU

Description of instruction

SD <timer> starts the addressed timer when the RLO transitions from "0" to "1". The programmed time interval elapses as long as RLO = 1. The time is stopped if RLO transitions to "0" before the programmed time interval has expired. This timer start instruction expects the time value and the time base to be stored as a BCD number in ACCU 1-L.

See also Location of a Timer in Memory and Components of a Timer.

Status word

	BIE	A1	A0	OV	OS	OR	STA	VKE	/ER
writes:	-	-	-	-	-	0	-	-	0

Example

STL	Explanation
A I 2.0	
FR T1	//Enable timer T1.
A I 2.1	
L S5T#10s	//Preset 10 seconds into ACCU 1.
SD T1	//Start timer T1 as an on-delay timer.
A I 2.2	
R T1	//Reset timer T1.
A T1	//Check signal state of timer T1.
= Q 4.0	
L T1	//Load current timer value of timer T1 as binary.
T MW10	
LC T1	//Load current timer value of timer T1 as BCD.
T MW12	

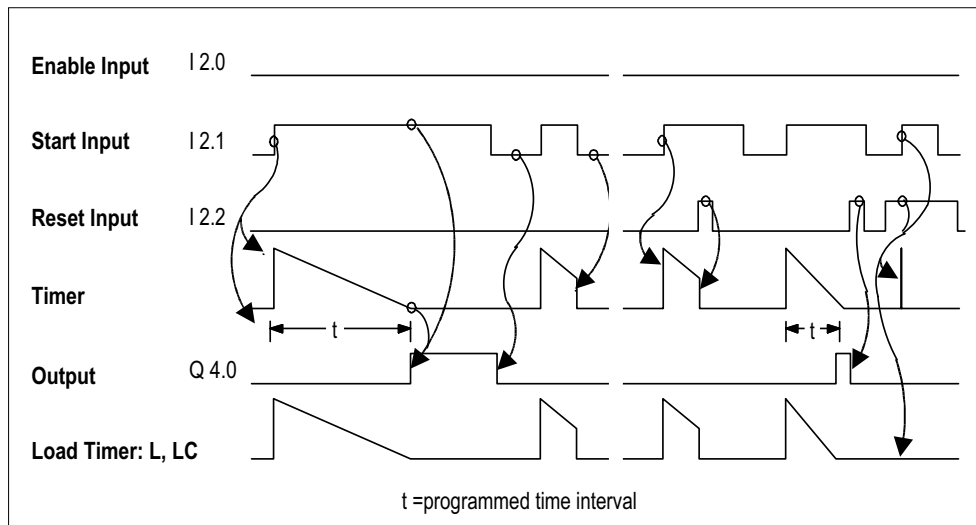

12.10 SS Retentive On-Delay Timer

Format

SS <timer>

Address	Data type	Memory area	Description
<timer>	TIMER	T	Timer number, range depends on CPU

Description of instruction

SS <timer> (start timer as a retentive ON timer) starts the addressed timer when the RLO transitions from "0" to "1". The full programmed time interval elapses, even if the RLO transitions to "0" in the meantime. The programmed time interval is re-triggered (started again) if RLO transitions from "0" to "1" before the programmed time has expired. This timer start command expects the time value and the time base to be stored as a BCD number in ACCU 1-L.

See also Location of a Timer in Memory and Components of a Timer.

Status word

	BIE	A1	A0	OV	OS	OR	STA	VKE	/ER
writes:	-	-	-	-	-	0	-	-	0

Example

STL	Explanation
A I 2.0	
FR T1	//Enable timer T1.
A I 2.1	
L S5T#10s	//Preset 10 seconds into ACCU 1.
SS T1	//Start timer T1 as a retentive on-delay timer.
A I 2.2	
R T1	//Reset timer T1.
A T1	//Check signal state of timer T1.
= Q 4.0	
L T1	//Load current time value of timer T1 as binary.
T MW10	
LC T1	//Load current time value of timer T1 as BCD.
T MW12	

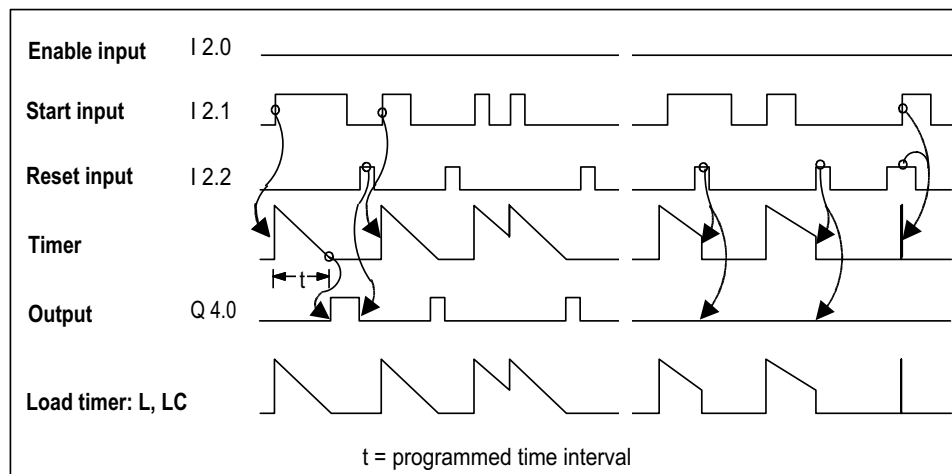

12.11 SF Off-Delay Timer

Format

SF <timer>

Address	Data type	Memory area	Description
<timer>	TIMER	T	Timer number, range depends on CPU

Description of instruction

SF <timer> starts the addressed timer when the RLO transitions from "1" to "0". The programmed time elapses as long as RLO = 0. The time is stopped if RLO transitions to "1" before the programmed time interval has expired. This timer start command expects the time value and the time base to be stored as a BCD number in ACCU 1-L.

See also Location of a Timer in Memory and Components of a Timer.

Status word

	BIE	A1	A0	OV	OS	OR	STA	VKE	/ER
writes:	-	-	-	-	-	0	-	-	0

Example

STL	Explanation
A I 2.0	
FR T1	//Enable timer T1.
A I 2.1	
L S5T#10s	//Preset 10 seconds into ACCU 1.
SF T1	//Start timer T1 as an off-delay timer.
A I 2.2	
R T1	//Reset timer T1.
A T1	//Check signal state of timer T1.
= Q 4.0	
L T1	//Load current timer value of timer T1 as binary.
T MW10	
LC T1	//Load current timer value of timer T1 as BCD.
T MW12	

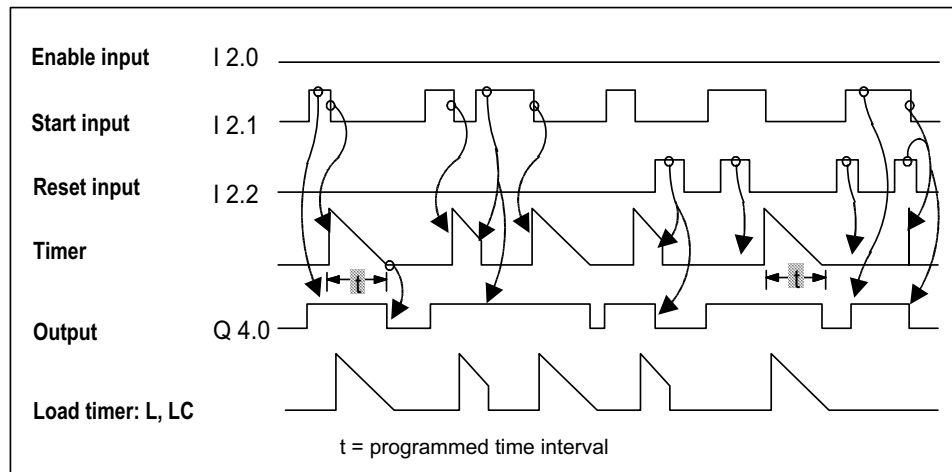

13 Word Logic Instructions

13.1 Overview of Word Logic Instructions

Description

Word logic instructions compare pairs of words (16 bits) and double words (32 bits) bit by bit, according to Boolean logic. Each word or double word must be in one of the two accumulators.

For words, the contents of the low word of accumulator 2 is combined with the contents of the low word of accumulator 1. The result of the combination is stored in the low word of accumulator 1, overwriting the old contents.

For double words, the contents of accumulator 2 is combined with the contents of accumulator 1. The result of the combination is stored in accumulator 1, overwriting the old contents.

If the result does not equal 0, bit CC 1 of the status word is set to "1". If the result does equal 0, bit CC 1 of the status word is set to "0".

The following instructions are available for performing Word Logic operations:

- AW AND Word (16-Bit)
- OW OR Word (16-Bit)
- XOW Exclusive OR Word (16-Bit)
- AD AND Double Word (32-Bit)
- OD OR Double Word (32-Bit)
- XOD Exclusive OR Double Word (32-Bit)

13.2 AW AND Word (16-Bit)

Format

AW
AW <constant>

Address	Data type	Description
<constant>	WORD, 16-bit constant	Bit pattern to be combined with ACCU 1-L by AND

Description of instruction

AW (AND word) combines the contents of ACCU 1-L with ACCU 2-L or a 16 bit-constant bit by bit according to the Boolean logic operation AND. A bit in the result word is "1" only when the corresponding bits of both words combined in the logic operation are "1". The result is stored in ACCU 1-L. ACCU 1-H and ACCU 2 (and ACCU 3 and ACCU 4 for CPUs with four ACCUs) remain unchanged. The status bit CC 1 is set as a result of the operation (CC 1 = 1 if result is unequal to zero). The status word bits CC 0 and OV are reset to 0.

AW: Combines ACCU 1-L with ACCU 2-L.

AW <constant>: Combines ACCU 1 with a 16-bit constant.

Status word

	BR	CC 1	CC 0	OV	OS	OR	STA	RLO	/FC
writes:	-	x	0	0	-	-	-	-	-

Examples

Bit	15...0
ACCU 1-L before execution of AW	0101	1001	0011	1011
ACCU 2-L or 16-bit constant:	1111	0110	1011	0101
Result (ACCU 1-L) after execution of AW	0101	0000	0011	0001

Example 1

STL	Explanation
L IW20	//Load contents of IW20 into ACCU 1-L.
L IW22	//Load contents of ACCU 1 into ACCU 2. Load contents of IW22 into ACCU 1-L.
AW	//Combine bits from ACCU 1-L with ACCU 2-L bits by AND; store result in ACCU 1-L.
T MW 8	//Transfer result to MW8.

Example 2

STL	Explanation
L IW20	//Load contents of IW20 into ACCU 1-L.
AW W#16#0FFF	//Combine bits of ACCU 1-L with bit pattern of 16-bit constant (0000_1111_1111_1111) by AND; store result in ACCU 1-L.
JP NEXT	//Jump to NEXT jump label if result is unequal to zero, (CC 1 = 1).

13.3 OW OR Word (16-Bit)

Format

OW
OW <constant>

Address	Data type	Description
<constant>	WORD, 16-bit constant	Bit pattern to be combined with ACCU 1-L by OR

Description of instruction

OW (OR word) combines the contents of ACCU 1-L with ACCU 2-L or a 16 bit-constant bit by bit according to the Boolean logic operation OR. A bit in the result word is "1" when at least one of the corresponding bits of both words combined in the logic operation is "1". The result is stored in ACCU 1-L. ACCU 1-H and ACCU 2 (and ACCU 3 and ACCU 4 for CPUs with four ACCUs) remain unchanged. The instruction is executed without regard to, and without affecting, the RLO. The status bit CC 1 is set as a result of the operation (CC 1 = 1 if result is unequal to zero). The status word bits CC 0 and OV are reset to 0.

OW: Combines ACCU 1-L with ACCU 2-L.

OW <constant>: Combines ACCU 1-L with a 16-bit constant.

Status word

	BR	CC 1	CC 0	OV	OS	OR	STA	RLO	/FC
writes:	-	x	0	0	-	-	-	-	-

Examples

Bit	15...0
ACCU 1-L before execution of OW	0101	0101	0011	1011
ACCU 2-L or 16 bit constant:	1111	0110	1011	0101
Result (ACCU 1-L) after execution of OW	1111	0111	1011	1111

Example 1

STL	Explanation
L IW20	//Load contents of IW20 into ACCU 1-L.
L IW22	//Load contents of ACCU 1 into ACCU 2. Load contents of IW22 into ACCU 1-L.
OW	//Combine bits from ACCU 1-L with ACCU 2-L by OR, store result in ACCU 1-L.
T MW8	//Transfer result to MW8.

Example 2

STL	Explanation
L IW20	//Load contents of IW 20 into ACCU 1-L.
OW W#16#0FFF	//Combine bits of ACCU 1-L with bit pattern of 16-bit constant (0000_1111_1111_1111) by OR; store result in ACCU 1-L.
JP NEXT	//Jump to NEXT jump label if result is unequal to zero (CC 1 = 1).

13.4 XOW Exclusive OR Word (16-Bit)

Format

XOW
XOW <constant>

Address	Data type	Description
<constant>	WORD, 16-bit constant	Bit pattern to be combined with ACCU 1-L by XOR (Exclusive Or)

Description of instruction

XOW (XOR word) combines the contents of ACCU 1-L with ACCU 2-L or a 16 bit-constant bit by bit according to the Boolean logic operation XOR. A bit in the result word is "1" only when one of the corresponding bits of both words combined in the logic operation is "1". The result is stored in ACCU 1-L. ACCU 1-H and ACCU 2 remain unchanged. The status bit CC 1 is set as a result of the operation (CC 1 = 1 if result is unequal to zero). The status word bits CC 0 and OV are reset to 0.

You can use the Exclusive OR function several times. The result of logic operation is then "1" if an impair number of checked addresses ist "1".

XOW: Combines ACCU 1-L with ACCU 2-L.

XOW <constant>: Combines ACCU 1-L with a 16-bit constant.

Status word

	BR	CC 1	CC 0	OV	OS	OR	STA	RLO	/FC
writes:	-	x	0	0	-	-	-	-	-

Examples

Bit	15...0
ACCU 1 before execution of XOW	0101	0101	0011	1011
ACCU 2-L or 16-bit constant:	1111	0110	1011	0101
Result (ACCU 1) after execution of XOW	1010	0011	1000	1110

Example 1

STL	Explanation
L IW20	//Load contents of IW20 into ACCU 1-L.
L IW22	//Load contents of ACCU 1 into ACCU 2. Load contents of ID24 into ACCU 1-L.
XOW	//Combine bits of ACCU 1-L with ACCU 2-L bits by XOR, store result in ACCU 1-L.
T MW8	//Transfer result to MW8.

Example 2

STL	Explanation
L IW20	//Load contents of IW20 into ACCU 1-L.
XOW 16#0FFF	//Combine bits of ACCU 1-L with bit pattern of 16-bit constant (0000_1111_1111_1111) by XOR, store result in ACCU 1-L.
JP NEXT	//Jump to NEXT jump label if result is unequal to zero, (CC 1 = 1).

13.5 AD AND Double Word (32-Bit)

Format

AD
AD <constant>

Address	Data type	Description
<constant>	DWORD, 32-bit constant	Bit pattern to be combined with ACCU 1 by AND

Description of instruction

AD (AND double word) combines the contents of ACCU 1 with ACCU 2 or a 32-bit constant bit by bit according to the Boolean logic operation AND. A bit in the result double word is "1" only when the corresponding bits of both double words combined in the logic operation are "1". The result is stored in ACCU 1. ACCU 2 (and ACCU 3 and ACCU 4 for CPU's with four ACCUs) remains unchanged. The status bit CC 1 is set as a result of the operation (CC 1 = 1 if result is unequal to zero). The status word bits CC 0 and OV are reset to 0.

AD: Combines ACCU 1 with ACCU 2.

AD <constant>: Combines ACCU 1 with a 32-bit constant.

Status word

	BR	CC 1	CC 0	OV	OS	OR	STA	RLO	/FC
writes:	-	x	0	0	-	-	-	-	-

Examples

Bit	31	0
ACCU 1 before execution of UD	0101	0000	1111	1100	1000	1001	0011	1011	
ACCU 2 or 32-bit constante	1111	0011	1000	0101	0111	0110	1011	0101	
Result (ACCU 1) after execution of UD	0101	0000	1000	0100	0000	0000	0011	0001	

Example 1

STL	Explanation
L ID20	//Load contents of ID20 into ACCU 1.
L ID24	//Load contents of ACCU 1 into ACCU 2. Load contents of ID24 into ACCU 1.
AD	//Combine bits from ACCU 1 with ACCU 2 by AND, store result in ACCU 1.
T MD8	//Transfer result to MD8.

Example 2

STL	Explanation
L ID 20	//Load contents of ID20 into ACCU 1.
AD DW#16#0FFF_EF21	//Combine bits of ACCU 1 with bit pattern of 32-bit constant (0000_1111_1111_1111_1110_1111_0010_0001) by AND; store result in ACCU 1.
JP NEXT	//Jump to NEXT jump label if result is unequal to zero, (CC 1 = 1).

13.6 OD OR Double Word (32-Bit)

Format

OD
OD <constant>

Address	Data type	Description
<constant>	DWORD, 32-bit constant	Bit pattern to be combined with ACCU 1 by OR

Description of instruction

OD (OR double word) combines the contents of ACCU 1 with ACCU 2 or a 32-bit constant bit by bit according to the Boolean logic operation OR. A bit in the result double word is "1" when at least one of the corresponding bits of both double words combined in the logic operation is "1". The result is stored in ACCU 1. ACCU 2 (and ACCU 3 and ACCU 4 for CPUs with four ACCUs) remains unchanged. The status bit CC 1 is set as a function of the result of the operation (CC 1 = 1 if result is unequal to zero). The status word bits CC 0 and OV are reset to 0.

OD: Combines ACCU 1 with ACCU 2.

OD <constant>: Combines ACCU 1 with a 32-bit constant.

Status word

	BR	CC 1	CC 0	OV	OS	OR	STA	RLO	/FC
writes:	-	x	0	0	-	-	-	-	-

Examples

Bit	31	0
ACCU 1 before execution of OD	0101	0000	1111	1100	1000	0101	0011	1011	
ACCU 2 or 32-bit constant:	1111	0011	1000	0101	0111	0110	1011	0101	
Result (ACCU 1) after execution of OD	1111	0011	1111	1101	1111	0111	1011	1111	

Example 1

STL	Explanation
L ID20	//Load contents of ID20 into ACCU 1.
L ID24	//Load contents of ACCU 1 into ACCU 2. Load contents of ID24 into ACCU 1.
OD	//Combine bits from ACCU 1 with ACCU 2 bits by OR; store result in ACCU 1.
T MD8	//Transfer result to MD8.

Example 2

STL	Explanation
L ID20	//Load contents of ID20 into ACCU 1.
OD DW#16#0FFF_EF21	//Combine bits of ACCU 1 with bit pattern of 32-bit constant (0000_1111_1111_1111_1110_1111_0010_0001) by OR, store result in ACCU 1.
JP NEXT	//Jump to NEXT jump label if result is not equal to zero, (CC 1 = 1).

13.7 XOD Exclusive OR Double Word (32-Bit)

Format

XOD
XOD <constant>

Address	Data type	Description
<constant>	DWORD, 32-bit constant	Bit pattern to be combined with ACCU 1 by XOR (Exclusive Or).

Description of instruction

XOD (XOR double word) combines the contents of ACCU 1 with ACCU 2 or a 32-bit constant bit by bit according to the Boolean logic operation XOR (Exclusive Or). A bit in the result double word is "1" when only one of the corresponding bits of both double words combined in the logic operation is "1". The result is stored in ACCU 1. ACCU 2 remains unchanged. The status bit CC 1 is set as a result of the operation (CC 1 = 1 if result is not equal to zero). The status word bits CC 0 and OV are reset to 0.

You can use the Exclusive OR function several times. The result of logic operation is then "1" if an impair number of checked addresses ist "1".

XOD: Combines ACCU 1 with ACCU 2.

XOD <constant>: Combines ACCU 1 with a 32-bit constant.

Status word

	BR	CC 1	CC 0	OV	OS	OR	STA	RLO	/FC
writes:	-	x	0	0	-	-	-	-	-

Examples

Bit	31	0
ACCU 1 before execution of XOD	0101	0000	1111	1100	1000	0101	0011	1011	
ACCU 2 or 32-bit constant	1111	0011	1000	0101	0111	0110	1011	0101	
Result (ACCU 1) after execution of XOD	1010	0011	0111	1001	1111	0011	1000	1110	

Example 1

STL	Explanation
L ID20	//Load contents of ID20 into ACCU 1.
L ID24	//Load contents of ACCU 1 into ACCU 2. Load contents of ID24 into ACCU 1.
XOD	//Combine bits from ACCU 1 with ACCU 2 by XOR; store result in ACCU 1.
T MD8	//Transfer result to MD8.

Example 2

STL	Explanation
L ID20	//Load contents of ID20 into ACCU 1.
XOD DW#16#0FFF_EF21	//Combine bits from ACCU 1 with bit pattern of 32-bit constant (0000_1111_1111_1111_1111_1110_0010_0001) by XOR, store result in ACCU 1.
JP NEXT	//Jump to NEXT jump label if result is unequal to zero, (CC 1 = 1).

14 Accumulator Instructions

14.1 Overview of Accumulator and Address Register Instructions

Description

The following instructions are available to you for handling the contents of one or both accumulators:

- TAK Toggle ACCU 1 with ACCU 2
- PUSH CPU with Two ACCUs
- PUSH CPU with Four ACCUs
- POP CPU with Two ACCUs
- POP CPU with Four ACCUs

- ENT Enter ACCU Stack
- LEAVE Leave ACCU Stack
- INC Increment ACCU 1-L-L
- DEC Decrement ACCU 1-L-L

- +AR1 Add ACCU 1 to Address Register 1
- +AR2 Add ACCU 1 to Address Register 2

- BLD Program Display Instruction (Null)
- NOP 0 Null Instruction
- NOP 1 Null Instruction

14.2 TAK Toggle ACCU 1 with ACCU 2

Format

TAK

Description

TAK (toggle ACCU 1 with ACCU 2) exchanges the contents of ACCU 1 with the contents of ACCU 2. The instruction is executed without regard to, and without affecting, the status bits. The contents of ACCU 3 and ACCU 4 remain unchanged for CPUs with four ACCU s.

Status word

	BR	CC 1	CC 0	OV	OS	OR	STA	RLO	/FC
writes:	-	-	-	-	-	-	-	-	-

Example: Subtract smaller value from greater value

STL	Explanation
L MW10	//Load contents of MW10 into ACCU 1-L.
L MW12	//Load contents of ACCU 1-L into ACCU 2-L. Load contents of MW12 into ACCU 1-L.
>I	//Check if ACCU 2-L (MW10) greater than ACCU 1-L (MW12) .
SPB NEXT	//Jump to NEXT jump label if ACCU 2 (MW10) is greater than ACCU 1 (MW12) .
TAK	//Swap contents ACCU 1 and ACCU 2
NEXT: -I	//Subtract contents of ACCU 2-L from contents of ACCU 1-L.
T MW14	//Transfer result (= greater value minus smaller value) to MW14.

Contents	ACCU 1	ACCU 2
before executing TAK instruction	<MW12>	<MW10>
after executing TAK instruction	<MW10>	<MW12>

14.3 POP CPU with Two ACCUs

Format

POP

Description

POP (CPU with two ACCUs) copies the entire contents of ACCU 2 to ACCU 1. ACCU 2 remains unchanged. The instruction is executed without regard to, and without affecting, the status bits.

Status word

	BR	CC 1	CC 0	OV	OS	OR	STA	RLO	/FC
writes:	-	-	-	-	-	-	-	-	-

Example

STL	Explanation
T MD10	//Transfer contents of ACCU 1 (= value A) to MD10
POP	//Copy entire contents of ACCU 2 to ACCU 1
T MD14	//Transfer contents of ACCU 1 (= value B) to MD14

Contents	ACCU 1	ACCU 2
before executing POP instruction	value A	value B
after executing POP instruction	value B	value B

14.4 POP CPU with Four ACCUs

Format

POP

Description

POP (CPU with four ACCUs) copies the entire contents of ACCU 2 to ACCU 1, the contents of ACCU 3 to ACCU 2, and the contents of ACCU 4 to ACCU 3. ACCU 4 remains unchanged. The instruction is executed without regard to, and without affecting, the status bits.

Status word

	BR	CC 1	CC 0	OV	OS	OR	STA	RLO	/FC
writes:	-	-	-	-	-	-	-	-	-

Example

STL	Explanation
T MD10	//Transfer contents of ACCU 1 (= value A) to MD10
POP	//Copy entire contents of ACCU 2 to ACCU 1
T MD14	//Transfer contents of ACCU 1 (= value B) to MD14

Contents	ACCU 1	ACCU 2	ACCU 3	ACCU 4
before executing POP instruction	value A	value B	value C	value D
after executing POP instruction	value B	value C	value D	value D

14.5 PUSH CPU with Two ACCUs

Format

PUSH

Description

PUSH (ACCU 1 to ACCU 2) copies the entire contents of ACCU 1 to ACCU 2. ACCU 1 remains unchanged. The instruction is executed without regard to, and without affecting, the status bits.

Status word

	BR	CC 1	CC 0	OV	OS	OR	STA	RLO	/FC
writes:	-	-	-	-	-	-	-	-	-

Example

STL	Explanation
L MW10	//Load the contents of MW10 into ACCU 1.
PUSH	//Copy entire contents of ACCU 1 into ACCU 2.

Contents	ACCU 1	ACCU 2
before executing PUSH instruction	<MW10>	<X>
after executing PUSH instruction	<MW10>	<MW10>

14.6 PUSH CPU with Four ACCUs

Format

PUSH

Description

PUSH (CPU with four ACCUs) copies the contents of ACCU 3 to ACCU 4, the contents of ACCU 2 to ACCU 3, and the contents of ACCU 1 to ACCU 2. ACCU 1 remains unchanged. The instruction is executed without regard to, and without affecting, the status bits.

Status word

	BR	CC 1	CC 0	OV	OS	OR	STA	RLO	/FC
writes:	-	-	-	-	-	-	-	-	-

Example

STL	Explanation
L MW10	//Load the contents of MW10 into ACCU 1.
PUSH	//Copy the entire contents of ACCU 1 to ACCU 2, the contents of ACCU 2 to ACCU 3, and the contents of ACCU 3 to ACCU 4.

Contents	ACCU 1	ACCU 2	ACCU 3	ACCU 4
before executing PUSH instruction	value A	value B	value C	value D
after executing PUSH instruction	value A	value A	value B	value C

14.7 ENT Enter ACCU Stack

Format

ENT

Description

ENT (enter accumulator stack) copies the contents of ACCU 3 into ACCU 4 and the contents of ACCU 2 into ACCU 3. If you program the ENT instruction directly in front of a load instruction, you can save an intermediate result in ACCU 3.

Example

STL	Explanation
L DBD0	//Load the value from data double word DBD0 into ACCU 1. (This value must be in the floating point format).
L DBD4	//Copy the value from ACCU 1 into ACCU 2. Load the value from data double word DBD4 into ACCU 1. (This value must be in the floating point format).
+R	//Add the contents of ACCU 1 and ACCU 2 as floating point numbers (32 bit, IEEE-FP) and save the result in ACCU 1.
L DBD8	//Copy the value from ACCU 1 into ACCU 2 load the value from data double word DBD8 into ACCU 1.
ENT	//Copy the contents of ACCU 3 into ACCU 4. Copy the contents of ACCU 2 (intermediate result) into ACCU 3.
L DBD12	//Load the value from data double word DBD12 into ACCU 1.
-R	//Subtract the contents of ACCU 1 from the contents of ACCU 2 and store the result in ACCU 1. Copy the contents of ACCU 3 into ACCU 2. Copy the contents of ACCU 4 into ACCU 3.
/R	//Divide the contents of ACCU 2 (DBD0 + DBD4) by the contents of ACCU 1 (DBD8 - DBD12). Save the result in ACCU 1.
T DBD16	//Transfer the results (ACCU 1) to data double word DBD16.

14.8 LEAVE Leave ACCU Stack

Format

LEAVE

Description

LEAVE (leave accumulator stack) copies the contents of ACCU 3 into ACCU 2 and the contents of ACCU 4 into ACCU 3. If you program the LEAVE instruction directly in front of a shift or rotate instruction, and combine the accumulators, then the leave instruction functions like an arithmetic instruction. The contents of ACCU 1 and ACCU 4 remain unchanged.

14.9 INC Increment ACCU 1-L-L

Format

INC <8-bit integer>

Parameter	Data Type	Description
<8-bit integer>	8-bit integer constant	Constant added to ACCU 1-L-L; range from 0 to 255

Description

INC <8-bit integer> (increment ACCU 1-L-L) adds the 8-bit integer to the contents of ACCU 1-L-L and stores the result in ACCU 1-L-L. ACCU 1-L-H, ACCU 1-H, and ACCU 2 remain unchanged. The instruction is executed without regard to, and without affecting, the status bits.

Note

These instructions are not suitable for 16-bit or 32-bit math because no carry is made from the low byte of the low word of accumulator 1 to the high byte of the low word of accumulator 1. For 16-bit or 32-bit math, use the +I or +D. instruction, respectively.

Status word

	BR	CC 1	CC 0	OV	OS	OR	STA	RLO	/FC
writes:	-	-	-	-	-	-	-	-	-

Example

STL	Explanation
L MB22	//Load the value of MB22
INC 1	//Instruction "Increment ACCU 1 (MB22) by 1"; store result in ACCU 1-L-L
T MB22	//Transfer the contents of ACCU 1-L-L (result) back to MB22

14.10 DEC Decrement ACCU 1-L-L

Format

DEC <8-bit integer>

Address	Data Type	Description
<8-bit integer>	8-bit integer constant	Constant subtracted from ACCU 1-L-L; range from 0 to 255

Description

DEC <8-bit integer> (decrement ACCU 1-L-L) subtracts the 8-bit integer from the contents of ACCU 1-L-L and stores the result in ACCU 1-L-L. ACCU 1-L-H, ACCU 1-H, and ACCU 2 remain unchanged. The instruction is executed without regard to, and without affecting, the status bits.

Note

These instructions are not suitable for 16-bit or 32-bit math because no carry is made from the low byte of the low word of accumulator 1 to the high byte of the low word of accumulator 1. For 16-bit or 32-bit math, use the +I or +D. instruction, respectively.

Status word

	BR	CC 1	CC 0	OV	OS	OR	STA	RLO	/FC
writes:	-	-	-	-	-	-	-	-	-

Example

STL	Explanation
L MB250	//Load the value of MB250
DEC 1	//Instruction "Decrement ACCU 1-L-L by 1"; store result in ACCU 1-L-L.
T MB250	//Transfer the contents of ACCU 1-L-L (result) back to MB250.

14.11 +AR1 Add ACCU 1 to Address Register 1

Format

+AR1
+AR1 <P#Byte.Bit>

Parameter	Data Type	Description
<P#Byte.Bit>	Pointer constant	Address added to AR1

Description

+AR1 (add to AR1) adds an offset specified either in the statement or in ACCU 1-L to the contents of AR1. The integer (16 bit) is initially expanded to 24 bits with its correct sign and then added to the least significant 24 bits of AR1 (part of the relative address in AR1). The part of the area ID in AR1 (bits 24, 25, and 26) remains unchanged. The instruction is executed without regard to, and without affecting, the status bits.

+AR1: The integer (16 bit) to be added to the contents of AR1 is specified by the value in ACCU 1-L. Values from -32768 to +32767 are permissible.

+AR1 <P#Byte.Bit>: The offset to be added is specified by the <P#Byte.Bit> address.

Status word

	BR	CC 1	CC 0	OV	OS	OR	STA	RLO	/FC
writes:	-	-	-	-	-	-	-	-	-

Example 1

STL	Explanation
L +300	//Load the value into ACCU 1-L
+AR1	//Add ACCU 1-L (integer, 16 bit) to AR1.

Example 2

STL	Explanation
+AR1 P#300.0	//Add the offset 300.0 to AR1.

14.12 +AR2 Add ACCU 1 to Address Register 2

Format

+AR2
+AR2 <P#Byte.Bit>

Parameter	Data Type	Description
<P#Byte.Bit>	Pointer constant	Address added to AR2

Description

+AR2 (add to AR2) adds an offset specified either in the instruction or in ACCU 1-L to the contents of AR. The integer (16 bit) is initially expanded to 2 bytes with its correct sign and then added to the least significant 24 bits of AR2 (part of the relative address in AR2). The part of the area ID in AR2 (bits 24, 25, and 26) remains unchanged. The instruction is executed without regard to, and without affecting, the status bits.

+AR2: The integer (16 bit) to be added to the contents of AR2 is specified by the value in ACCU 1-L. Values from -32768 to +32767 are permissible.

+AR2 <P#Byte.Bit>: The offset to be added is specified by the <P#Byte.Bit> address.

Status word

	BR	CC 1	CC 0	OV	OS	OR	STA	RLO	/FC
writes:	-	-	-	-	-	-	-	-	-

Example 1

STL	Explanation
L +300	//Load the value in ACCU 1-L.
+AR1	//Add ACCU 1-L (integer, 16 bit) to AR2.

Example 2

STL	Explanation
+AR1 P#300.0	//Add the offset 30.0 to AR2.

14.13 BLD Program Display Instruction (Null)

Format

BLD <number>

Address	Description
<number>	Number specifies BLD instruction, range from 0 to 255

Description

BLD <number> (program display instruction; null instruction) executes no function and does not affect the status bits. The instruction is used for the programming device (PG) for graphic display. It is created automatically when a Ladder or FBD program is displayed in STL. The address <number> specifies the BLD instruction and is generated by the programming device.

Status word

	BR	CC 1	CC 0	OV	OS	OR	STA	RLO	/FC
writes:	-	-	-	-	-	-	-	-	-

14.14 NOP 0 Null Instruction

Format

NOP 0

Description

NOP 0 (Instruction NOP with address "0") executes no function and does not affect the status bits. The instruction code contains a bit pattern with 16 zeros. The instruction is of interest only to the programming device (PG) when a program is displayed.

Status word

	BR	CC 1	CC 0	OV	OS	OR	STA	RLO	/FC
writes:	-	-	-	-	-	-	-	-	-

14.15 NOP 1 Null Instruction

Format

NOP 1

Description

NOP 1 (Instruction NOP with address "1") executes no function and does not affect the status bits. The instruction code contains a bit pattern with 16 ones. The instruction is of interest only to the programming device (PG) when a program is displayed.

Status word

	BR	CC 1	CC 0	OV	OS	OR	STA	RLO	/FC
writes:	-	-	-	-	-	-	-	-	-

A Overview of All STL Instructions

A.1 STL Instructions Sorted According to German Mnemonics (SIMATIC)

German Mnemonics	English Mnemonics	Program Elements Catalog	Description
+	+	Integer math Instruction	Add Integer Constant (16, 32-Bit)
=	=	Bit logic Instruction	Assign
))	Bit logic Instruction	Nesting Closed
+AR1	+AR1	Accumulator	AR1 Add ACCU 1 to Address Register 1
+AR2	+AR2	Accumulator	AR2 Add ACCU 1 to Address Register 2
+D	+D	Integer math Instruction	Add ACCU 1 and ACCU 2 as Double Integer (32-Bit)
-D	-D	Integer math Instruction	Subtract ACCU 1 from ACCU 2 as Double Integer (32-Bit)
*D	*D	Integer math Instruction	Multiply ACCU 1 and ACCU 2 as Double Integer (32-Bit)
/D	/D	Integer math Instruction	Divide ACCU 2 by ACCU 1 as Double Integer (32-Bit)
? D	? D	Compare	Compare Double Integer (32-Bit) ==, <>, >, <, >=, <=
+I	+I	Integer math Instruction	Add ACCU 1 and ACCU 2 as Integer (16-Bit)
-I	-I	Integer math Instruction	Subtract ACCU 1 from ACCU 2 as Integer (16-Bit)
*I	*I	Integer math Instruction	Multiply ACCU 1 and ACCU 2 as Integer (16-Bit)
/I	/I	Integer math Instruction	Divide ACCU 2 by ACCU 1 as Integer (16-Bit)
? I	? I	Compare	Compare Integer (16-Bit) ==, <>, >, <, >=, <=
+R	+R	Floating point Instruction	Add ACCU 1 and ACCU 2 as a Floating-Point Number (32-Bit IEEE-FP)
-R	-R	Floating point Instruction	Subtract ACCU 1 from ACCU 2 as a Floating-Point Number (32-Bit IEEE-FP)
*R	*R	Floating point Instruction	Multiply ACCU 1 and ACCU 2 as Floating-Point Numbers (32-Bit IEEE-FP)
/R	/R	Floating point Instruction	Divide ACCU 2 by ACCU 1 as a Floating-Point Number (32-Bit IEEE-FP)

German Mnemonics	English Mnemonics	Program Elements Catalog	Description
? R	? R	Compare	Compare Floating-Point Number (32-Bit) ==, <>, >, <, >=, <=
ABS	ABS	Floating point Instruction	Absolute Value of a Floating-Point Number (32-Bit IEEE-FP)
ACOS	ACOS	Floating point Instruction	Generate the Arc Cosine of a Floating-Point Number (32-Bit)
ASIN	ASIN	Floating point Instruction	Generate the Arc Sine of a Floating-Point Number (32-Bit)
ATAN	ATAN	Floating point Instruction	Generate the Arc Tangent of a Floating-Point Number (32-Bit)
AUF	OPN	DB call	Open a Data Block
BE	BE	Program control	Block End
BEA	BEU	Program control	Block End Unconditional
BEB	BEC	Program control	Block End Conditional
BLD	BLD	Program control	Program Display Instruction (Null)
BTD	BTD	Convert	BCD to Integer (32-Bit)
BTI	BTI	Convert	BCD to Integer (16-Bit)
CALL	CALL	Program control	Block Call
CALL	CALL	Program control	Call Multiple Instance
CALL	CALL	Program control	Call Block from a Library
CC	CC	Program control	Conditional Call
CLR	CLR	Bit logic Instruction	Clear RLO (=0)
COS	COS	Floating point Instruction	Generate the Cosine of Angles as Floating-Point Numbers (32-Bit)
DEC	DEC	Accumulator	Decrement ACCU 1-L-L
DTB	DTB	Convert	Double Integer (32-Bit) to BCD
DTR	DTR	Convert	Double Integer (32-Bit) to Floating-Point (32-Bit IEEE-FP)
ENT	ENT	Accumulator	Enter ACCU Stack
EXP	EXP	Floating point Instruction	Generate the Exponential Value of a Floating-Point Number (32-Bit)
FN	FN	Bit logic Instruction	Edge Negative
FP	FP	Bit logic Instruction	Edge Positive
FR	FR	Counters	Enable Counter (Free) (free, FR C 0 to C 255)
FR	FR	Timers	Enable Timer (Free)
INC	INC	Accumulator	Increment ACCU 1-L-L

German Mnemonics	English Mnemonics	Program Elements Catalog	Description
INVD	INVD	Convert	Ones Complement Double Integer (32-Bit)
INVI	INVI	Convert	Ones Complement Integer (16-Bit)
ITB	ITB	Convert	Integer (16-Bit) to BCD
ITD	ITD	Convert	Integer (16-Bit) to Double Integer (32-Bit)
L	L	Load/Transfer	Load
L DBLG	L DBLG	Load/Transfer	Load Length of Shared DB in ACCU 1
L DBNO	L DBNO	Load/Transfer	Load Number of Shared DB in ACCU 1
L DILG	L DILG	Load/Transfer	Load Length of Instance DB in ACCU 1
L DINO	L DINO	Load/Transfer	Load Number of Instance DB in ACCU 1
L STW	L STW	Load/Transfer	Load Status Word into ACCU 1
L	L	Load/Transfer	Load Current Timer Value into ACCU 1 as Integer_(the current timer value can be a number from 0 to 255, for example, L T 32)
L	L	Load/Transfer	Load Current Counter Value into ACCU 1_(the current counter value can be a number from 0 to 255, for example, L C 15)
LAR1	LAR1	Load/Transfer	Load Address Register 1 from ACCU 1
LAR1	LAR1	Load/Transfer	Load Address Register 1 with Double Integer (32-Bit Pointer)
LAR1	LAR1	Load/Transfer	Load Address Register 1 from Address Register 2
LAR2	LAR2	Load/Transfer	Load Address Register 2 from ACCU 1
LAR2	LAR2	Load/Transfer	Load Address Register 2 with Double Integer (32-Bit Pointer)
LC	LC	Counters	Load Current Counter Value into ACCU 1 as BCD_(the current timer value can be a number from 0 to 255, for example, LC C 15)
LC	LC	Timers	Load Current Timer Value into ACCU 1 as BCD_(the current counter value can be a number from 0 to 255, for example, LC T 32)
LEAVE	LEAVE	Accumulator	Leave ACCU Stack
LN	LN	Floating point Instruction	Generate the Natural Logarithm of a Floating-Point Number (32-Bit)
LOOP	LOOP	Jumps	Loop
MCR(MCR(Program control	Save RLO in MCR Stack, Begin MCR
)MCR)MCR	Program control	End MCR
MCRA	MCRA	Program control	Activate MCR Area
MCRD	MCRD	Program control	Deactivate MCR Area
MOD	MOD	Integer math Instruction	Division Remainder Double Integer (32-Bit)
NEGD	NEGD	Convert	Twos Complement Double Integer (32-Bit)

German Mnemonics	English Mnemonics	Program Elements Catalog	Description
NEGI	NEGI	Convert	Twos Complement Integer (16-Bit)
NEGR	NEGR	Convert	Negate Floating-Point Number (32-Bit, IEEE-FP)
NOP 0	NOP 0	Accumulator	Null Instruction
NOP 1	NOP 1	Accumulator	Null Instruction
NOT	NOT	Bit logic Instruction	Negate RLO
O	O	Bit logic Instruction	Or
O(O(Bit logic Instruction	Or with Nesting Open
OD	OD	Word logic Instruction	OR Double Word (32-Bit)
ON	ON	Bit logic Instruction	Or Not
ON(ON(Bit logic Instruction	Or Not with Nesting Open
OW	OW	Word logic Instruction	OR Word (16-Bit)
POP	POP	Accumulator	POP
POP	POP	Accumulator	CPU with Two ACCUs
POP	POP	Accumulator	CPU with Four ACCUs
PUSH	PUSH	Accumulator	CPU with Two ACCUs
PUSH	PUSH	Accumulator	CPU with Four ACCUs
R	R	Bit logic Instruction	Reset
R	R	Counters	Reset Counter _n (the current counter can be a number from 0 to 255, for example, R C 15)
R	R	Timers	Reset Timer _n (the current timer can be a number from 0 to 255, for example, R T 32)
RLD	RLD	Shift/Rotate	Rotate Left Double Word (32-Bit)
RLDA	RLDA	Shift/Rotate	Rotate ACCU 1 Left via CC 1 (32-Bit)
RND	RND	Convert	Round
RND+	RND+	Convert	Round to Upper Double Integer
RND-	RND-	Convert	Round to Lower Double Integer
RRD	RRD	Shift/Rotate	Rotate Right Double Word (32-Bit)
RRDA	RRDA	Shift/Rotate	Rotate ACCU 1 Right via CC 1 (32-Bit)
S	S	Bit logic Instruction	Set
S	S	Counters	Set Counter Preset Value _n (the current counter can be a number from 0 to 255, for example, S C 15)
SA	SF	Timers	Off-Delay Timer
SAVE	SAVE	Bit logic Instruction	Save RLO in BR Register
SE	SD	Timers	On-Delay Timer

German Mnemonics	English Mnemonics	Program Elements Catalog	Description
SET	SET	Bit logic Instruction	Set
SI	SP	Timers	Pulse Timer
SIN	SIN	Floating point Instruction	Generate the Sine of Angles as Floating-Point Numbers (32-Bit)
SLD	SLD	Shift/Rotate	Shift Left Double Word (32-Bit)
SLW	SLW	Shift/Rotate	Shift Left Word (16-Bit)
SPA	JU	Jumps	Jump Unconditional
SPB	JC	Jumps	Jump if RLO = 1
SPBB	JCB	Jumps	Jump if RLO = 1 with BR
SPBI	JB	Jumps	Jump if BR = 1
SPBIN	JNBI	Jumps	Jump if BR = 0
SPBN	JCN	Jumps	Jump if RLO = 0
SPBNB	JNB	Jumps	Jump if RLO = 0 with BR
SPL	JL	Jumps	Jump to Labels
SPM	JM	Jumps	Jump if Minus
SPMZ	JMZ	Jumps	Jump if Minus or Zero
SPN	JN	Jumps	Jump if Not Zero
SPO	JO	Jumps	Jump if OV = 1
SPP	JP	Jumps	Jump if Plus
SPPZ	JPZ	Jumps	Jump if Plus or Zero
SPS	JOS	Jumps	Jump if OS = 1
SPU	JUO	Jumps	Jump if Unordered
SPZ	JZ	Jumps	Jump if Zero
SQR	SQR	Floating point Instruction	Generate the Square of a Floating-Point Number (32-Bit)
SQRT	SQRT	Floating point Instruction	Generate the Square Root of a Floating-Point Number (32-Bit)
SRD	SRD	Shift/Rotate	Shift Right Double Word (32-Bit)
SRW	SRW	Shift/Rotate	Shift Right Word (16-Bit)
SS	SS	Timers	Retentive On-Delay Timer
SSD	SSD	Shift/Rotate	Shift Sign Double Integer (32-Bit)
SSI	SSI	Shift/Rotate	Shift Sign Integer (16-Bit)
SV	SE	Timers	Extended Pulse Timer
T	T	Load/Transfer	Transfer
T STW	T STW	Load/Transfer	Transfer ACCU 1 into Status Word
TAD	CAD	Convert	Change Byte Sequence in ACCU 1 (32-Bit)
TAK	TAK	Accumulator	Toggle ACCU 1 with ACCU 2
TAN	TAN	Floating point Instruction	Generate the Tangent of Angles as Floating-Point Numbers (32-Bit)
TAR	CAR	Load/Transfer	Exchange Address Register 1 with Address Register 2
TAR1	TAR1	Load/Transfer	Transfer Address Register 1 to ACCU 1

German Mnemonics	English Mnemonics	Program Elements Catalog	Description
TAR1	TAR1	Load/Transfer	Transfer Address Register 1 to Destination (32-Bit Pointer)
TAR1	TAR1	Load/Transfer	Transfer Address Register 1 to Address Register 2
TAR2	TAR2	Load/Transfer	Transfer Address Register 2 to ACCU 1
TAR2	TAR2	Load/Transfer	Transfer Address Register 2 to Destination (32-Bit Pointer)
TAW	CAW	Convert	Change Byte Sequence in ACCU 1-L (16-Bit)
TDB	CDB	Convert	Exchange Shared DB and Instance DB
TRUNC	TRUNC	Convert	Truncate
U	A	Bit logic Instruction	And
U(A(Bit logic Instruction	And with Nesting Open
UC	UC	Program control	Unconditional Call
UD	AD	Word logic Instruction	AND Double Word (32-Bit)
UN	AN	Bit logic Instruction	And Not
UN(AN(Bit logic Instruction	And Not with Nesting Open
UW	AW	Word logic Instruction	AND Word (16-Bit)
X	X	Bit logic Instruction	Exclusive Or
X(X(Bit logic Instruction	Exclusive Or with Nesting Open
XN	XN	Bit logic Instruction	Exclusive Or Not
XN(XN(Bit logic Instruction	Exclusive Or Not with Nesting Open
XOD	XOD	Word logic Instruction	Exclusive OR Double Word (32-Bit)
XOW	XOW	Word logic Instruction	Exclusive OR Word (16-Bit)
ZR	CD	Counters	Counter Down
ZV	CU	Counters	Counter Up

A.2 STL Instructions Sorted According to English Mnemonics (International)

English Mnemonics	German Mnemonics	Program Elements Catalog	Description
+	+	Integer math Instruction	Add Integer Constant (16, 32-Bit)
=	=	Bit logic Instruction	Assign
))	Bit logic Instruction	Nesting Closed
+AR1	+AR1	Accumulator	AR1 Add ACCU 1 to Address Register 1
+AR2	+AR2	Accumulator	AR2 Add ACCU 1 to Address Register 2
+D	+D	Integer math Instruction	Add ACCU 1 and ACCU 2 as Double Integer (32-Bit)
-D	-D	Integer math Instruction	Subtract ACCU 1 from ACCU 2 as Double Integer (32-Bit)
*D	*D	Integer math Instruction	Multiply ACCU 1 and ACCU 2 as Double Integer (32-Bit)
/D	/D	Integer math Instruction	Divide ACCU 2 by ACCU 1 as Double Integer (32-Bit)
? D	? D	Compare	Compare Double Integer (32-Bit) ==, <>, >, <, >=, <=
+I	+I	Integer math Instruction	Add ACCU 1 and ACCU 2 as Integer (16-Bit)
-I	-I	Integer math Instruction	Subtract ACCU 1 from ACCU 2 as Integer (16-Bit)
*I	*I	Integer math Instruction	Multiply ACCU 1 and ACCU 2 as Integer (16-Bit)
/I	/I	Integer math Instruction	Divide ACCU 2 by ACCU 1 as Integer (16-Bit)
? I	? I	Compare	Compare Integer (16-Bit) ==, <>, >, <, >=, <=
+R	+R	Floating point Instruction	Add ACCU 1 and ACCU 2 as a Floating-Point Number (32-Bit IEEE-FP)
-R	-R	Floating point Instruction	Subtract ACCU 1 from ACCU 2 as a Floating-Point Number (32-Bit IEEE-FP)
*R	*R	Floating point Instruction	Multiply ACCU 1 and ACCU 2 as Floating-Point Numbers (32-Bit IEEE-FP)
/R	/R	Floating point Instruction	Divide ACCU 2 by ACCU 1 as a Floating-Point Number (32-Bit IEEE-FP)
? R	? R	Compare	Compare Floating-Point Number (32-Bit) ==, <>, >, <, >=, <=
A	U	Bit logic Instruction	And
A(U(Bit logic Instruction	And with Nesting Open
ABS	ABS	Floating point Instruction	Absolute Value of a Floating-Point Number (32-Bit IEEE-FP)

English Mnemonics	German Mnemonics	Program Elements Catalog	Description
ACOS	ACOS	Floating point Instruction	Generate the Arc Cosine of a Floating-Point Number (32-Bit)
AD	UD	Word logic Instruction	AND Double Word (32-Bit)
AN	UN	Bit logic Instruction	And Not
AN(UN(Bit logic Instruction	And Not with Nesting Open
ASIN	ASIN	Floating point Instruction	Generate the Arc Sine of a Floating-Point Number (32-Bit)
ATAN	ATAN	Floating point Instruction	Generate the Arc Tangent of a Floating-Point Number (32-Bit)
AW	UW	Word logic Instruction	AND Word (16-Bit)
BE	BE	Program control	Block End
BEC	BEB	Program control	Block End Conditional
BEU	BEA	Program control	Block End Unconditional
BLD	BLD	Program control	Program Display Instruction (Null)
BTD	BTD	Convert	BCD to Integer (32-Bit)
BTI	BTI	Convert	BCD to Integer (16-Bit)
CAD	TAD	Convert	Change Byte Sequence in ACCU 1 (32-Bit)
CALL	CALL	Program control	Block Call
CALL	CALL	Program control	Call Multiple Instance
CALL	CALL	Program control	Call Block from a Library
CAR	TAR	Load/Transfer	Exchange Address Register 1 with Address Register 2
CAW	TAW	Convert	Change Byte Sequence in ACCU 1-L (16-Bit)
CC	CC	Program control	Conditional Call
CD	ZR	Counters	Counter Down
CDB	TDB	Convert	Exchange Shared DB and Instance DB
CLR	CLR	Bit logic Instruction	Clear RLO (=0)
COS	COS	Floating point Instruction	Generate the Cosine of Angles as Floating-Point Numbers (32-Bit)
CU	ZV	Counters	Counter Up
DEC	DEC	Accumulator	Decrement ACCU 1-L-L
DTB	DTB	Convert	Double Integer (32-Bit) to BCD
DTR	DTR	Convert	Double Integer (32-Bit) to Floating-Point (32-Bit IEEE-FP)
ENT	ENT	Accumulator	Enter ACCU Stack
EXP	EXP	Floating point Instruction	Generate the Exponential Value of a Floating-Point Number (32-Bit)
FN	FN	Bit logic Instruction	Edge Negative
FP	FP	Bit logic Instruction	Edge Positive
FR	FR	Counters	Enable Counter (Free) (free, FR C 0 to C 255)

English Mnemonics	German Mnemonics	Program Elements Catalog	Description
FR	FR	Timers	Enable Timer (Free)
INC	INC	Accumulator	Increment ACCU 1-L-L
INVD	INVD	Convert	Ones Complement Double Integer (32-Bit)
INVI	INVI	Convert	Ones Complement Integer (16-Bit)
ITB	ITB	Convert	Integer (16-Bit) to BCD
ITD	ITD	Convert	Integer (16-Bit) to Double Integer (32-Bit)
JBI	SPBI	Jumps	Jump if BR = 1
JC	SPB	Jumps	Jump if RLO = 1
JCB	SPBB	Jumps	Jump if RLO = 1 with BR
JCN	SPBN	Jumps	Jump if RLO = 0
JL	SPL	Jumps	Jump to Labels
JM	SPM	Jumps	Jump if Minus
JMZ	SPMZ	Jumps	Jump if Minus or Zero
JN	SPN	Jumps	Jump if Not Zero
JNB	SPBNB	Jumps	Jump if RLO = 0 with BR
JNBI	SPBIN	Jumps	Jump if BR = 0
JO	SPO	Jumps	Jump if OV = 1
JOS	SPS	Jumps	Jump if OS = 1
JP	SPP	Jumps	Jump if Plus
JPZ	SPPZ	Jumps	Jump if Plus or Zero
JU	SPA	Jumps	Jump Unconditional
JUO	SPU	Jumps	Jump if Unordered
JZ	SPZ	Jumps	Jump if Zero
L	L	Load/Transfer	Load
L DBLG	L DBLG	Load/Transfer	Load Length of Shared DB in ACCU 1
L DBNO	L DBNO	Load/Transfer	Load Number of Shared DB in ACCU 1
L DILG	L DILG	Load/Transfer	Load Length of Instance DB in ACCU 1
L DINO	L DINO	Load/Transfer	Load Number of Instance DB in ACCU 1
L STW	L STW	Load/Transfer	Load Status Word into ACCU 1
L	L	Timers	Load Current Timer Value into ACCU 1 as Integer (the current timer value can be a number from 0 to 255, for example, L T 32)
L	L	Counters	Load Current Counter Value into ACCU 1 (the current counter value can be a number from 0 to 255, for example, L C 15)
LAR1	LAR1	Load/Transfer	Load Address Register 1 from ACCU 1
LAR1 <D>	LAR1<D>	Load/Transfer	Load Address Register 1 with Double Integer (32-Bit Pointer)
LAR1 AR2	LAR1 AR2	Load/Transfer	Load Address Register 1 from Address Register 2
LAR2	LAR2	Load/Transfer	Load Address Register 2 from ACCU 1
LAR2 <D>	LAR2 <D>	Load/Transfer	Load Address Register 2 with Double Integer (32-Bit Pointer)

English Mnemonics	German Mnemonics	Program Elements Catalog	Description
LC	LC	Counters	Load Current Counter Value into ACCU 1 as BCD ₂ (the current timer value can be a number from 0 to 255, for example, LC C 15)
LC	LC	Timers	Load Current Timer Value into ACCU 1 as BCD ₂ (the current counter value can be a number from 0 to 255, for example, LC T 32)
LEAVE	LEAVE	Accumulator	Leave ACCU Stack
LN	LN	Floating point Instruction	Generate the Natural Logarithm of a Floating-Point Number (32-Bit)
LOOP	LOOP	Jumps	Loop
MCR(MCR(Program control	Save RLO in MCR Stack, Begin MCR
)MCR)MCR	Program control	End MCR
MCRA	MCRA	Program control	Activate MCR Area
MCRD	MCRD	Program control	Deactivate MCR Area
MOD	MOD	Integer math Instruction	Division Remainder Double Integer (32-Bit)
NEGD	NEGD	Convert	Twos Complement Double Integer (32-Bit)
NEGI	NEGI	Convert	Twos Complement Integer (16-Bit)
NEGR	NEGR	Convert	Negate Floating-Point Number (32-Bit, IEEE-FP)
NOP 0	NOP 0	Accumulator	Null Instruction
NOP 1	NOP 1	Accumulator	Null Instruction
NOT	NOT	Bit logic Instruction	Negate RLO
O	O	Bit logic Instruction	Or
O(O(Bit logic Instruction	Or with Nesting Open
OD	OD	Word logic Instruction	OR Double Word (32-Bit)
ON	ON	Bit logic Instruction	Or Not
ON(ON(Bit logic Instruction	Or Not with Nesting Open
OPN	AUF	DB call	Open a Data Block
OW	OW	Word logic Instruction	OR Word (16-Bit)
POP	POP	Accumulator	POP
POP	POP	Accumulator	CPU with Two ACCUs
POP	POP	Accumulator	CPU with Four ACCUs
PUSH	PUSH	Accumulator	CPU with Two ACCUs
PUSH	PUSH	Accumulator	CPU with Four ACCUs
R	R	Bit logic Instruction	Reset
R	R	Counters	Reset Counter ₂ (the current counter can be a number from 0 to 255, for example, R C 15)

English Mnemonics	German Mnemonics	Program Elements Catalog	Description
R	R	Timers	Reset Timer (the current timer can be a number from 0 to 255, for example, R T 32)
RLD	RLD	Shift/Rotate	Rotate Left Double Word (32-Bit)
RLDA	RLDA	Shift/Rotate	Rotate ACCU 1 Left via CC 1 (32-Bit)
RND	RND	Convert	Round
RND-	RND-	Convert	Round to Lower Double Integer
RND+	RND+	Convert	Round to Upper Double Integer
RRD	RRD	Shift/Rotate	Rotate Right Double Word (32-Bit)
RRDA	RRDA	Shift/Rotate	Rotate ACCU 1 Right via CC 1 (32-Bit)
S	S	Bit logic Instruction	Set
S	S	Counters	Set Counter Preset Value (the current counter can be a number from 0 to 255, for example, S C 15)
SAVE	SAVE	Bit logic Instruction	Save RLO in BR Register
SD	SE	Timers	On-Delay Timer
SE	SV	Timers	Extended Pulse Timer
SET	SET	Bit logic Instruction	Set
SF	SA	Timers	Off-Delay Timer
SIN	SIN	Floating point Instruction	Generate the Sine of Angles as Floating-Point Numbers (32-Bit)
SLD	SLD	Shift/Rotate	Shift Left Double Word (32-Bit)
SLW	SLW	Shift/Rotate	Shift Left Word (16-Bit)
SP	SI	Timers	Pulse Timer
SQR	SQR	Floating point Instruction	Generate the Square of a Floating-Point Number (32-Bit)
SQRT	SQRT	Floating point Instruction	Generate the Square Root of a Floating-Point Number (32-Bit)
SRD	SRD	Shift/Rotate	Shift Right Double Word (32-Bit)
SRW	SRW	Shift/Rotate	Shift Right Word (16-Bit)
SS	SS	Timers	Retentive On-Delay Timer
SSD	SSD	Shift/Rotate	Shift Sign Double Integer (32-Bit)
SSI	SSI	Shift/Rotate	Shift Sign Integer (16-Bit)
T	T	Load/Transfer	Transfer
T STW	T STW	Load/Transfer	Transfer ACCU 1 into Status Word
TAK	TAK	Accumulator	Toggle ACCU 1 with ACCU 2
TAN	TAN	Floating point Instruction	Generate the Tangent of Angles as Floating-Point Numbers (32-Bit)
TAR1	TAR1	Load/Transfer	Transfer Address Register 1 to ACCU 1
TAR1	TAR1	Load/Transfer	Transfer Address Register 1 to Destination (32-Bit Pointer)
TAR1	TAR1	Load/Transfer	Transfer Address Register 1 to Address Register 2
TAR2	TAR2	Load/Transfer	Transfer Address Register 2 to ACCU 1

English Mnemonics	German Mnemonics	Program Elements Catalog	Description
TAR2	TAR2	Load/Transfer	Transfer Address Register 2 to Destination (32-Bit Pointer)
TRUNC	TRUNC	Convert	Truncate
UC	UC	Program control	Unconditional Call
X	X	Bit logic Instruction	Exclusive Or
X(X(Bit logic Instruction	Exclusive Or with Nesting Open
XN	XN	Bit logic Instruction	Exclusive Or Not
XN(XN(Bit logic Instruction	Exclusive Or Not with Nesting Open
XOD	XOD	Word logic Instruction	Exclusive OR Double Word (32-Bit)
XOW	XOW	Word logic Instruction	Exclusive OR Word (16-Bit)

B Programming Examples

B.1 Overview of Programming Examples

Practical Applications

Each statement list instruction triggers a specific operation. When you combine these instructions into a program, you can accomplish a wide variety of automation tasks. This chapter provides the following examples of practical applications of the statement list instructions:

- Controlling a conveyor belt using bit logic instructions
- Detecting direction of movement on a conveyor belt using bit logic instructions
- Generating a clock pulse using timer instructions
- Keeping track of storage space using counter and comparison instructions
- Solving a problem using integer math instructions
- Setting the length of time for heating an oven

Instructions Used

Mnemonic	Program Elements Catalog	Description
AW	Word logic instruction	And Word
OW	Word logic instruction	Or Word
CD, CU	Counters	Counter Down, Counter Up
S, R	Bit logic instruction	Set, Reset
NOT	Bit logic instruction	Negate RLO
FP	Bit logic instruction	Edge Positive
+I	Floating-Point instruction	Add Accumulators 1 and 2 as Integer
/I	Floating-Point instruction	Divide Accumulator 2 by Accumulator 1 as Integer
*I	Floating-Point instruction	Multiply Accumulators 1 and 2 as Integers
>=I, <=I	Compare	Compare Integer
A, AN	Bit logic instruction	And, And Not
O, ON	Bit logic instruction	Or, Or Not
=	Bit logic instruction	Assign
INC	Accumulator	Increment Accumulator 1
BE, BEC	Program Control	Block End and Block End Conditional
L, T	Load / Transfer	Load and Transfer
SE	Timers	Extended Pulse Timer

B.2 Example: Bit Logic Instructions

Example 1: Controlling a Conveyor Belt

The following figure shows a conveyor belt that can be activated electrically. There are two push button switches at the beginning of the belt: S1 for START and S2 for STOP. There are also two push button switches at the end of the belt: S3 for START and S4 for STOP. It is possible to start or stop the belt from either end. Also, sensor S5 stops the belt when an item on the belt reaches the end.

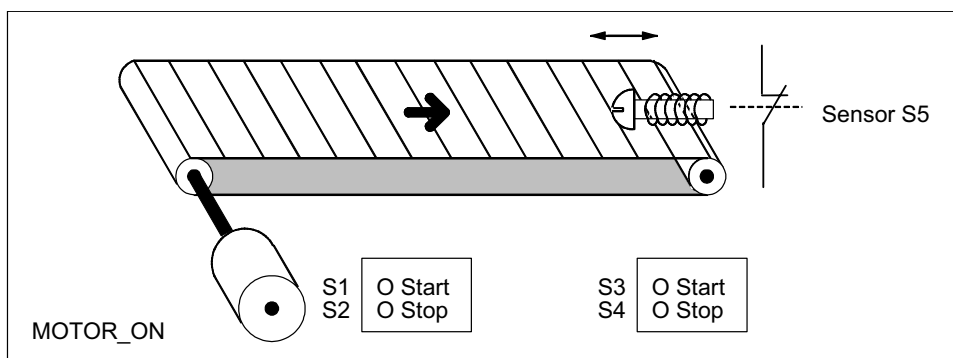

Absolute and symbolic Programming

You can write a program to control the conveyor belt using **absolute values** or **symbols** that represent the various components of the conveyor system.

You need to make a symbol table to correlate the symbols you choose with absolute values (see the STEP 7 Online Help).

System Component	Absolute Address	Symbol	Symbol Table
Push Button Start Switch	I 1.1	S1	I 1.1 S1
Push Button Stop Switch	I 1.2	S2	I 1.2 S2
Push Button Start Switch	I 1.3	S3	I 1.3 S3
Push Button Stop Switch	I 1.4	S4	I 1.4 S4
Sensor	I 1.5	S5	I 1.5 S5
Motor	Q 4.0	MOTOR_ON	Q 4.0 MOTOR_ON

Absolute Program	Symbolic Program
O I 1.1	O S1
O I 1.3	O S3
S Q 4.0	S MOTOR_ON
O I 1.2	O S2
O I 1.4	O S4
ON I 1.5	ON S5
R Q 4.0	R MOTOR_ON

Statement List to control the Conveyor Belt

STL	Explanation
O I 1.1	//Pressing either start switch turns the motor on.
O I 1.3	
S Q 4.0	
O I 1.2	//Pressing either stop switch or opening the normally closed contact at the end of the belt turns the motor off.
O I 1.4	
ON I 1.5	
R Q 4.0	

Example 2: Detecting the Direction of a Conveyor Belt

The following figure shows a conveyor belt that is equipped with two photoelectric barriers (PEB1 and PEB2) that are designed to detect the direction in which a package is moving on the belt. Each photoelectric light barrier functions like a normally open contact.

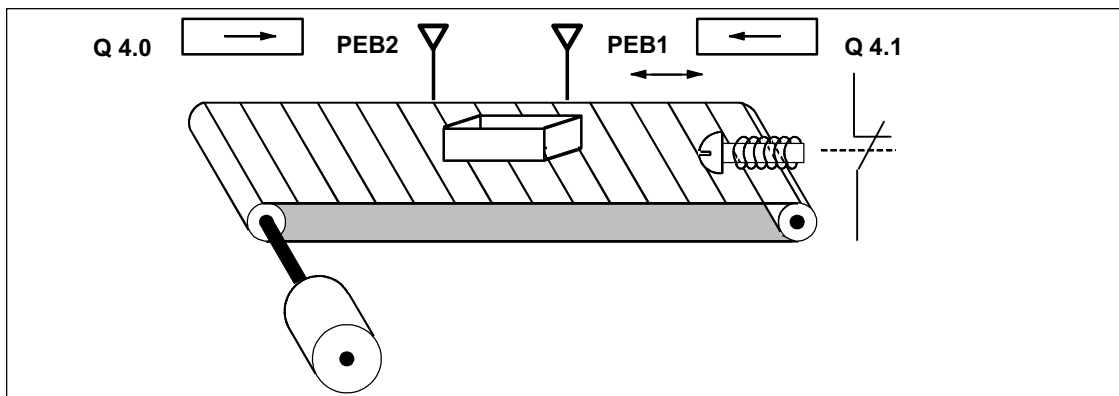

Absolute and symbolic Programming

You can write a program to activate a direction display for the conveyor belt system using **absolute values** or **symbols** that represent the various components of the conveyor system.

You need to make a symbol table to correlate the symbols you choose with absolute values (see the STEP 7 Online Help).

System Component	Absolute Address	Symbol	Symbol Table
Photoelectric barrier 1	I 0.0	PEB1	I 0.0 PEB1
Photoelectric barrier 2	I 0.1	PEB2	I 0.1 PEB2
Display for movement to right	Q 4.0	RIGHT	Q 4.0 RIGHT
Display for movement to left	Q 4.1	LEFT	Q 4.1 LEFT
Pulse memory bit 1	M 0.0	PMB1	M 0.0 PMB1
Pulse memory bit 2	M 0.1	PMB2	M 0.1 PMB2

Absolute Program	Symbolic Program
A I 0.0	A PEB1
FP M 0.0	FP PMB1
AN I 0.1	AN PEB 2
S Q 4.1	S LEFT
A I 0.1	A PEB 2
FP M 0.1	FP PMB 2
AN I 0.0	AN PEB 1
S Q 4.0	S RIGHT
AN I 0.0	AN PEB 1
AN I 0.1	AN PEB 2
R Q 4.0	R RIGHT
R Q 4.1	R LEFT

Statement List

STL	Explanation
A I 0.0	//If there is a transition in signal state from 0 to 1 (positive edge) at input I 0.0 and, at the same time, the signal state at input I 0.1 is 0, then the package on the belt is moving to the left.
FP M 0.0	
AN I 0.1	
S Q 4.1	
A I 0.1	//If there is a transition in signal state from 0 to 1 (positive edge) at input I 0.1 and, at the same time, the signal state at input I 0.0 is 0, then the package on the belt is moving to the right. If one of the photo-electric light barriers is broken, this means that there is a package between the barriers.
FP M 0.1	
AN I 0.0	
S Q 4.0	
AN I 0.0	//If neither photoelectric barrier is broken, then there is no package between the barriers. The direction pointer shuts off.
AN I 0.1	
R Q 4.0	
R Q 4.1	

B.3 Example: Timer Instructions

Clock Pulse Generator

You can use a clock pulse generator or flasher relay when you need to produce a signal that repeats periodically. A clock pulse generator is common in a signalling system that controls the flashing of indicator lamps.

When you use the S7-300, you can implement the clock pulse generator function by using time-driven processing in special organization blocks. The example shown in the following statement list, however, illustrates the use of timer functions to generate a clock pulse. The sample program shows how to implement a freewheeling clock pulse generator by using a timer.

Statement List to Generate a Clock Pulse (pulse duty factor 1:1)

STL	Explanation
U T1	//If timer T 1 has expired,
L S5T#250ms	//load the time value 250 ms into T 1 and
SV T1	//start T 1 as an extended-pulse timer.
NOT	//Negate (invert) the result of logic operation.
BEB	//If the timer is running, end the current block.
L MB100	//If the timer has expired, load the contents of memory byte MB100,
INC 1	//increment the contents by 1,
T MB100	//and transfer the result to memory byte MB100.

Signal Check

A signal check of timer T1 produces the following result of logic operation (RLO).

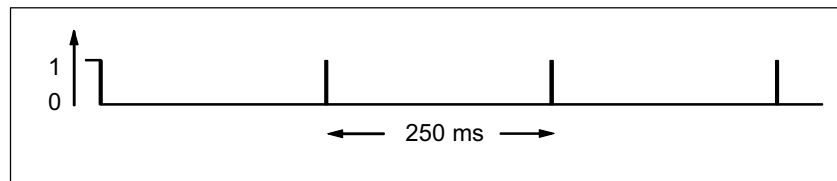

As soon as the time runs out, the timer is restarted. Because of this, the signal check made the statement **AN T1** produces a signal state of 1 only briefly.

The negated (inverted) RLO:

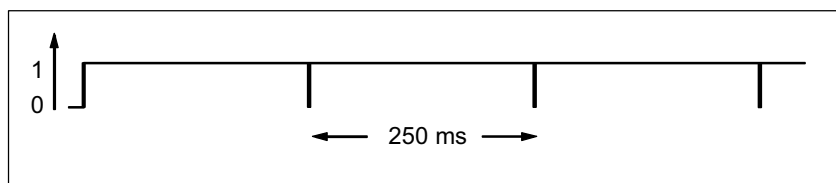

Every 250 ms the RLO bit is 0. Then the BEC statement does not end the processing of the block. Instead, the contents of memory byte MB100 is incremented by 1.

The contents of memory byte MB100 changes every 250 ms as follows:

0 -> 1 -> 2 -> 3 -> ... -> 254 -> 255 -> 0 -> 1 ...

Achieving a Specific Frequency

From the individual bits of memory byte MB100 you can achieve the following frequencies:

Bits of MB100	Frequency in Hertz	Duration
M 100.0	2.0	0.5 s (250 ms on / 250 ms off)
M 100.1	1.0	1 s (0.5 s on / 0.5 s off)
M 100.2	0.5	2 s (1 s on / 1 s off)
M 100.3	0.25	4 s (2 s on / 2 s off)
M 100.4	0.125	8 s (4 s on / 4 s off)
M 100.5	0.0625	16 s (8 s on / 8 s off)
M 100.6	0.03125	32 s (16 s on / 16 s off)
M 100.7	0.015625	64 s (32 s on / 32 s off)

Statement List

STL	Explanation
A M10.0	//M 10.0 = 1 when a fault occurs. The fault lamp blinks at a frequency of 1 Hz when a fault occurs.
A M100.1	
= Q 4.0	

Signal states of the Bits of Memory MB 101

Scan Cycle	Bit 7	Bit 6	Bit 5	Bit 4	Bit 3	Bit 2	Bit 1	Bit 0	Time Value in ms
0	0	0	0	0	0	0	0	0	250
1	0	0	0	0	0	0	0	1	250
2	0	0	0	0	0	0	1	0	250
3	0	0	0	0	0	0	1	1	250
4	0	0	0	0	0	1	0	0	250
5	0	0	0	0	0	1	0	1	250
6	0	0	0	0	0	1	1	0	250
7	0	0	0	0	0	1	1	1	250
8	0	0	0	0	1	0	0	0	250
9	0	0	0	0	1	0	0	1	250
10	0	0	0	0	1	0	1	0	250
11	0	0	0	0	1	0	1	1	250
12	0	0	0	0	1	1	0	0	250

Signal state of Bit 1 of MB 101 (M 101.1)

Frequency = $1/T = 1/1 \text{ s} = 1 \text{ Hz}$

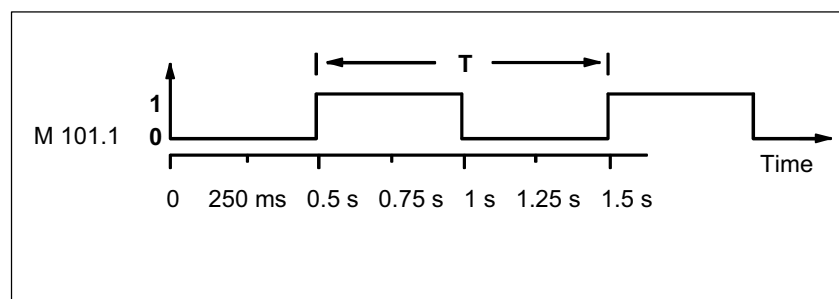

B.4 Example: Counter and Comparison Instructions

Storage Area with Counter and Comparator

The following figure shows a system with two conveyor belts and a temporary storage area in between them. Conveyor belt 1 delivers packages to the storage area. A photoelectric barrier at the end of conveyor belt 1 near the storage area determines how many packages are delivered to the storage area. Conveyor belt 2 transports packages from the temporary storage area to a loading dock where trucks take the packages away for delivery to customers. A photoelectric barrier at the end of conveyor belt 2 near the storage area determines how many packages leave the storage area to go to the loading dock. A display panel with five lamps indicates the fill level of the temporary storage area.

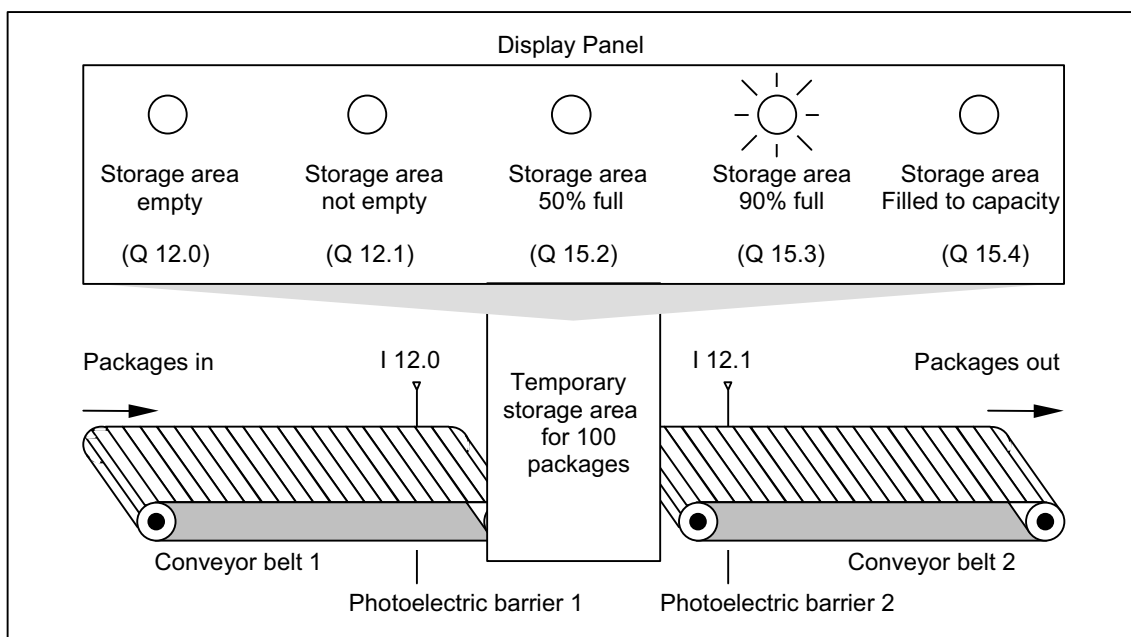

Statement List that Activates the Indicator Lamps on the Display Panel

STL	Explanation
A I 0.0	//Each pulse generated by photoelectric barrier 1
CU C1	//increases the count value of counter C 1 by one, thereby counting the number of packages going into the storage area.
	//
A I 0.1	//Each pulse generated by photoelectric barrier 2
CD C1	//decreases the count value of counter C 1 by one, thereby counting the packages that leave the storage area.
	//
AN C1	//If the count value is 0,
= Q 4.0	//the indicator lamp for "Storage area empty" comes on.
	//
A C1	//If the count value is not 0,
= A 4.1	//the indicator lamp for "Storage area not empty" comes on.
	//
L 50	
L C1	
<=I	//If 50 is less than or equal to the count value,
= Q 4.2	//the indicator lamp for "Storage area 50% full" comes on.
	//
L 90	
>=I	//If the count value is greater than or equal to 90,
= Q 4.3	//the indicator lamp for "Storage area 90% full" comes on.
	//
L Z1	
L 100	
>=I	//If the count value is greater than or equal to 100,
= Q 4.4	//the indicator lamp for "Storage area filled to capacity" comes on. (You could also use output Q 4.4 to lock conveyor belt 1.)

B.5 Example: Integer Math Instructions

Solving a Math Problem

The sample program shows you how to use three integer math instructions to produce the same result as the following equation:

$$MD4 = ((IW0 + DBW3) \times 15) / MW2$$

Statement List

STL		Explanation
L	EW0	//Load the value from input word IW0 into accumulator 1.
L	DB5.DBW3	//Load the value from shared data word DBW3 of DB5 into accumulator 1. The old contents of accumulator 1 are shifted to accumulator 2.
+I	I 0.1	//Add the contents of the low words of accumulators 1 and 2. The result is stored in the low word of accumulator 1. The contents of accumulator 2 and the high word of accumulator 1 remain unchanged.
L	+15	//Load the constant value +15 into accumulator 1. The old contents of accumulator 1 are shifted to accumulator 2.
*I		//Multiply the contents of the low word of accumulator 2 by the contents of the low word of accumulator 1. The result is stored in accumulator 1. The contents of accumulator 2 remain unchanged.
L	MW2	//Load the value from memory word MW2 into accumulator 1. The old contents of accumulator 1 are shifted to accumulator 2.
/I		//Divide the contents of the low word of accumulator 2 by the contents of the low word of accumulator 1. The result is stored in accumulator 1. The contents of accumulator 2 remain unchanged.
T	MD4	//Transfer the final result to memory double word MD4. The contents of both accumulators remain unchanged.

B.6 Example: Word Logic Instructions

Heating an Oven

The operator of the oven starts the oven heating by pushing the start push button. The operator can set the length of time for heating by using the thumbwheel switches shown in the figure. The value that the operator sets indicates seconds in binary coded decimal (BCD) format.

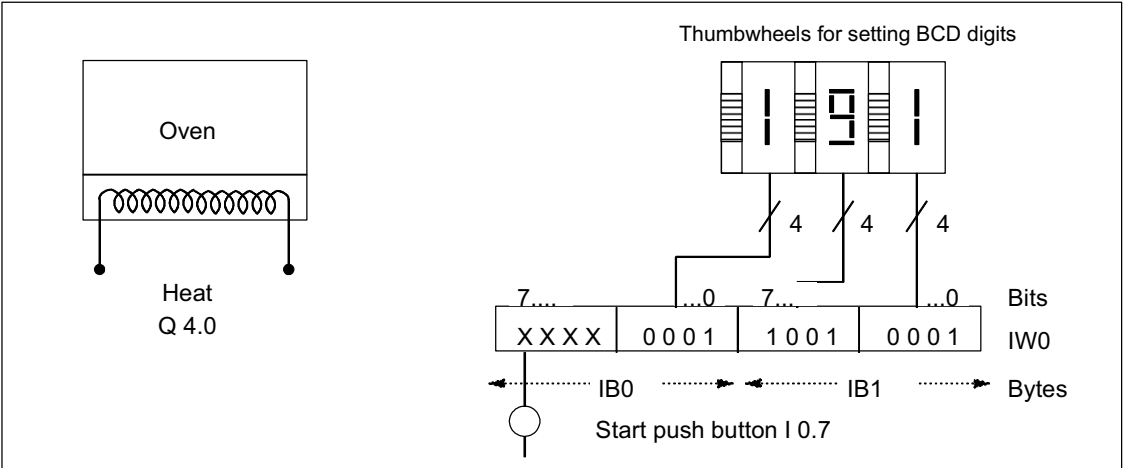

System Component	Absolute Address
Start Push Button	I 0.7
Thumbwheel for ones	I 1.0 to I 1.3
Thumbwheel for tens	I 1.4 to I 1.7
Thumbwheel for hundreds	I 0.0 to I 0.3
Heating starts	Q 4.0

Statement List

STL	Explanation
A T1	//If the timer is running,
= Q 4.0	//then turn on the heat.
BEC	//If the timer is running, then end processing here. This prevents timer T1 from being restarted if the push button is pressed.
L IW0	
AW W#16#0FFF	//Mask input bits I 0.4 through I 0.7 (that is, reset them to 0). The time value in seconds is in the low word of accumulator 1 in binary coded decimal format.
OW W#16#2000	Assign the time base as seconds in bits 12 and 13 of the low word of accumulator 1.
A I 0.7	
SE T1	//Start timer T1 as an extended pulse timer if the push button is pressed.

C Parameter Transfer

The parameters of a block are transferred as a value. With function blocks a copy of the actual parameter value in the instance data block is used in the called block. With functions a copy of the actual value lies in the local data stack. Pointers are not copied. Prior to the call the INPUT values are copied into the instance DB or to the L stack. After the call the OUTPUT values are copied back into the variables. Within the called block you can only work on a copy. The STL instructions required for this are in the calling block and remain hidden from the user.

Note

If memory bits, inputs, outputs or peripheral I/Os are used as actual address of a function they are treated in a different way than the other addresses. Here, updates are carried out directly, not via L Stack.



Caution

When programming the called block, ensure that the parameters declared as OUTPUT are also written. Otherwise the values output are random! With function blocks the value will be the value from the instance DB noted by the last call, with functions the value will be the value which happens to be in the L stack.

Note the following points:

- Initialize all OUTPUT parameters if possible.
 - Try not to use any Set and Reset instructions. These instructions are dependent on the RLO. If the RLO has the value 0, the random value will be retained.
 - If you jump within the block, ensure that you do not skip any locations where OUTPUT parameters are written. Do not forget BEC and the effect of the MCR instructions.
-

Index

)	
)	1-14
)MCR	10-22
*	
*D	7-12
*I	7-5
*R	8-7
/	
/D	7-13, 7-14
/I	7-6, 7-7
/R	8-8
?	
? D	2-3
? I	2-2
+	
+	7-8
+AR1	14-10
+AR2	14-11
+D	7-10
+I	7-3
+R	8-3, 8-4
=	
=	1-16
A	
A	1-3
A(1-10
ABS	8-9
Absolute Value of a Floating-Point Number (32-Bit IEEE-FP)	8-9
Accumulator operations and Address Register Instructions	14-1
ACOS	8-18
Activate MCR Area	10-23
AD	13-8, 13-9
Add ACCU 1 and ACCU 2 as a Floating-Point Number (32-Bit IEEE-FP)	8-3

Add ACCU 1 and ACCU 2 as Double Integer (32-Bit)	7-10
Add ACCU 1 and ACCU 2 as Integer (16-Bit)	7-3
Add ACCU 1 to Address Register 1	14-10
Add ACCU 1 to Address Register 2	14-11
Add Integer Constant (16 32-Bit)	7-8
AN	1-4
AN(1-11
And	1-3
And before Or	1-9
AND Double Word (32-Bit)	13-8
And Not	1-4
And Not with Nesting Open	1-11
And with Nesting Open	1-10
AND Word (16-Bit)	13-2
Area in memory	4-1, 12-2
ASIN	8-17
Assign	1-16
ATAN	8-19
AW	13-2, 13-3

B

BCD to Integer (16-Bit)	3-2
BCD to Integer (32-Bit)	3-4
BE	10-2
BEC	10-3
BEU	10-4
Bit Configuration in ACCU 1	12-3
BLD	14-12
Block Call	10-5
Block End	10-2
Block End Conditional	10-3
Block End Unconditional	10-4
BTD	3-4
BTI	3-2

C

CAD	3-14
CALL	10-5, 10-6
Call Block from a Library	10-14
Call FB	10-7
Call FC	10-9
Call Multiple Instance	10-14
Call SFB	10-11
Call SFC	10-13
CAR	9-11

- CAW 3-13
 CC 10-15
 CD 4-8
 CDB 5-3
 Change Byte Sequence in ACCU 1
 (32-Bit) 3-14
 Change Byte Sequence in ACCU 1-L
 (16-Bit) 3-13
 Choosing the right Timer 12-4
 Clear RLO (=0) 1-21
 CLR 1-21
 Compare Double Integer (32-Bit) 2-3
 Compare Floating-Point Number (32-Bit) 2-4
 Compare Integer (16-Bit) 2-2
 Components of a timer 12-1, 12-2
 Conditional Call 10-15
 COS 8-15
 count value 4-1
 Counter Down 4-8
 Counter Up 4-7
 CU 4-7
- D**
- D 7-11
 Deactivate MCR Area 10-24
 DEC 14-9
 Decrement ACCU 1-L-L 14-9
 Divide ACCU 2 by ACCU 1 as a
 Floating-Point Number
 (32-Bit IEEE-FP) 8-8
 Divide ACCU 2 by ACCU 1 as
 Double Integer (32-Bit) 7-13
 Divide ACCU 2 by ACCU 1 as
 Integer (16-Bit) 7-6
 Division Remainder Double Integer
 (32-Bit) 7-15
 Double Integer (32-Bit) to BCD 3-6
 Double Integer (32-Bit) to Floating-Point
 (32-Bit IEEE-FP) 3-7
 DTB 3-6
 DTR 3-7
- E**
- Edge Negative 1-23
 Edge Positive 1-25
 Enable Counter (Free) 4-2
 Enable Timer (Free) 12-5
 End MCR 10-22
 ENT 14-7
 Enter ACCU Stack 14-7
 Evaluating the Bits of the Status Word
 with Integer Math Instructions 7-2
 Evaluation of the Bits in the Status Word
 with Floating-Point Math Instructions.. 8-2
- Example
 Bit Logic Instructions B-2
 Counter and Comparison Instructions
 B-10
 Integer Math Instructions B-12
 Timer Instructions B-7
 Word Logic Instructions B-13
 Examples B-1
 Exchange Address Register 1
 with Address Register 2 9-11
 Exchange Shared DB and Instance DB . 5-3
 Exclusive Or 1-7
 Exclusive OR Double Word (32-Bit) ... 13-12
 Exclusive Or Not 1-8
 Exclusive Or Not with Nesting Open 1-13
 Exclusive Or with Nesting Open 1-12
 Exclusive OR Word (16-Bit) 13-6
 EXP 8-12
 Extended Pulse Timer 12-14
- F**
- FN 1-23
 FP 1-25
 FR 4-2, 12-5
 Function Block Call 10-8
 Function Call 10-9
- G**
- Generate the Arc Cosine of a
 Floating-Point Number (32-Bit) 8-18
 Generate the Arc Sine of a
 Floating-Point Number (32-Bit) 8-17
 Generate the Arc Tangent of a
 Floating-Point Number (32-Bit) 8-19
 Generate the Cosine of Angles as
 Floating-Point Numbers (32-Bit) 8-15
 Generate the Exponential Value of a
 Floating-Point Number (32-Bit) 8-12
 Generate the Natural Logarithm of a
 Floating-Point Number (32-Bit) 8-13
 Generate the Sine of Angles as
 Floating-Point Numbers (32-Bit) 8-14
 Generate the Square of a Floating-Point
 Number (32-Bit) 8-10
 Generate the Square Root of a
 Floating-Point Number (32-Bit) 8-11
 Generate the Tangent of Angles as
 Floating-Point Numbers (32-Bit) 8-16

I		L	
-I	7-4	L	9-2, 12-7
Important Notes on Using MCR Functions	10-19	L DBLG	5-4
INC	14-8	L DBNO	5-4
Increment ACCU 1-L-L	14-8	L DILG	5-5
Integer (16-Bit) to BCD	3-3	L DINO	5-5
Integer (16-Bit) to Double Integer (32-Bit)	3-5	L STW	9-4
INVD	3-9	LAR1	9-5
INVI	3-8	LAR1 <D> Load Address Register 1 with Double Integer (32-Bit Pointer)	9-6
ITB	3-3	LAR1 AR2	9-7
ITD	3-5	LAR2	9-7
		LAR2 <D>	9-8
J		LC	12-9
JBI	6-9	LEAVE	14-7
JC	6-5	Leave ACCU Stack	14-7
JCB	6-7	LN	8-13
JCN	6-6	Load	9-3
JL	6-4	Load Address Register 1 from ACCU 1 ..	9-5
JM	6-16	Load Address Register 1 from Address Register 2	9-7
JMZ	6-18	Load Address Register 2 from ACCU 1 ..	9-7
JN	6-14	Load Address Register 2 with Double Integer (32-Bit Pointer)	9-8
JNB	6-8	Load Current Timer Value into ACCU 1 as BCD	12-9
JNBI	6-10	Load Current Timer Value into ACCU 1 as Integer	12-7
JO	6-11	Load Length of Instance DB in ACCU 1 ..	5-5
JOS	6-12	Load Length of Shared DB in ACCU 1 ...	5-4
JP	6-15	Load Number of Instance DB in ACCU 1	5-5
JPZ	6-17	Load Number of Shared DB in ACCU 1 ..	5-4
JU	6-3	Load Status Word into ACCU 1	9-4
Jump if BR = 0	6-10	Location of a timer in memory	12-1, 12-2
Jump if BR = 1	6-9	Loop	6-20
Jump if Minus	6-16	LOOP	6-20
Jump if Minus or Zero	6-18		
Jump if Not Zero	6-14	M	
Jump if OS = 1	6-12	MCR	10-23, 10-24
Jump if OV = 1	6-11	MCR (Master Control Relay)	10-17
Jump if Plus	6-15	MCR Area	10-21, 10-22, 10-23
Jump if Plus or Zero	6-17	MCR(.....	10-20, 10-21
Jump if RLO = 0	6-6	MCRA	10-23
Jump if RLO = 0 with BR	6-8	MCRD	10-24
Jump if RLO = 1	6-5	Mnemonics	
Jump if RLO = 1 with BR	6-7	English	A-7
Jump if Unordered	6-19	Mnemonics German/SIMATIC	A-1
Jump if Zero	6-13	MOD	7-15, 7-16
Jump to Labels	6-4	Multiply ACCU 1 and ACCU 2 as Double Integer (32-Bit)	7-12
Jump Unconditional	6-3	Multiply ACCU 1 and ACCU 2 as Floating-Point Numbers (32-Bit IEEE-FP)	8-7
JUO	6-19		
JZ	6-13		

Multiply ACCU 1 and ACCU 2 as Integer
(16-Bit) 7-5

N

Negate Floating-Point Number (32-Bit
IEEE-FP) 3-12
Negate RLO 1-19
NEGD 3-11
NEGI 3-10
NEGR 3-12
Nesting Closed 1-14
NOP 0 14-12
NOP 1 14-13
NOT 1-19
Null Instruction 14-12, **14-13**

O

O 1-5, 1-9
O(..... 1-11
OD 13-10, 13-11
Off-Delay Timer 12-20
ON 1-6
ON(..... 1-12
On-Delay Timer 12-16
Ones Complement Double Integer (32-Bit)
..... 3-9
Ones Complement Integer (16-Bit) 3-8
Open a Data Block 5-2
OPN 5-2
Or 1-5
OR Double Word (32-Bit) 13-10
Or Not 1-6
Or Not with Nesting Open 1-12
Or with Nesting Open 1-11
OR Word (16-Bit) 13-4
Overview of Word Logic instructions... 13-1
Overview of Bit Logic instructions 1-1
Overview of Comparison instructions..... 2-1
Overview of Conversion instructions 3-1
Overview of Counter Instructions 4-1
Overview of Data Block instructions..... 5-1
Overview of Floating-Point Math
instructions 8-1
Overview of Integer Math Instructions... 7-1
Overview of Load and Transfer
instructions 9-1
Overview of Logic Control instructions... 6-1
Overview of Program Control
instructions 10-1
Overview of Programming Examples B-1
Overview of Rotate instructions 11-14
Overview of Shift instructions 11-1
Overview of Timer instructions 12-1
OW 13-4, 13-5

P

Parameter Transfer C-1
POP 14-3, 14-4
 CPU with Four ACCUs 14-4
 CPU with Two ACCUs 14-3
Practical Applications B-1
Program Display Instruction 14-12
Pulse Timer 12-12
PUSH 14-5, 14-6
 CPU with Four ACCUs 14-6
 CPU with Two ACCUs 14-5

R

R 1-17, 4-5, 12-11
-R 8-5, 8-6
Reset 1-17
Reset Counter 4-5
Reset Timer 12-11
Retentive On-Delay Timer 12-18
RLD 11-15, 11-16
RLDA 11-19
RND 3-15
RND- 3-18
RND+ 3-17
Rotate ACCU 1 Left via CC 1 (32-Bit) 11-19
Rotate ACCU 1 Right via CC 1 (32-Bit)
..... 11-20
Rotate Left Double Word (32-Bit) 11-15
Rotate Right Double Word (32-Bit) 11-17
Round 3-15
Round to Lower Double Integer 3-18
Round to Upper Double Integer 3-17
RRD 11-17, 11-18
RRDA 11-20

S

S 1-18, 4-6
SAVE 1-22
Save RLO in BR Register 1-22
Save RLO in MCR Stack
 Begin MCR 10-20
SD 12-16
SE 12-14
Set 1-18
SET 1-20
Set Counter Preset Value 4-6
Set RLO (=1) 1-20
SF 12-20
Shift Left Double Word (32-Bit) 11-10
Shift Left Word (16-Bit) 11-6
Shift Right Double Word (32-Bit) 11-12
Shift Right Word (16-Bit) 11-8
Shift Sign Double Integer (32-Bit) 11-4
Shift Sign Integer (16-Bit) 11-2
SIN 8-14

SLD.....	11-10, 11-11
SLW.....	11-6, 11-7
SP.....	12-12
SQR.....	8-10
SQRT.....	8-11
SRD.....	11-12, 11-13
SRW.....	11-8, 11-9
SS.....	12-18
SSD.....	11-4, 11-5
SSI.....	11-2
STL Instructions Sorted According to English Mnemonics (International)	A-7
STL Instructions Sorted According to German Mnemonics (SIMATIC)	A-1
Subtract ACCU 1 from ACCU 2 as a Floating-Point Number (32-Bit IEEE-FP).....	8-5
Subtract ACCU 1 from ACCU 2 as Double Integer (32-Bit).....	7-11
Subtract ACCU 1 from ACCU 2 as Integer (16-Bit).....	7-4
System Function Block Call.....	10-12
System Function Call	10-13
T	
T	9-9
T STW	9-10
TAK.....	14-2
TAN	8-16
TAR1	9-11
TAR1 <D>.....	9-12
TAR1 AR2	9-13
TAR2	9-13
TAR2 <D>.....	9-14
Time Base.....	12-2, 12-3
Time Value.....	12-2, 12-3, 12-4
Toggle ACCU 1 with ACCU 2.....	14-2
Transfer.....	9-9
Transfer ACCU 1 into Status Word.....	9-10
Transfer Address Register 1 to ACCU 1	9-11
Transfer Address Register 1 to Address Register 2.....	9-13
Transfer Address Register 1 to Destination (32 Bit Pointer)	9-12
Transfer Address Register 2 to ACCU 1	9-13
Transfer Address Register 2 to Destination (32-Bit Pointer).....	9-14
TRUNC	3-16
Truncate.....	3-16
Twos Complement Double Integer (32-Bit).....	3-11
Twos Complement Integer (16-Bit).....	3-10
U	
UC.....	10-16
Unconditional Call.....	10-16
X	
X	1-7
X(.....	1-12
XN.....	1-8
XN(.....	1-13
XOD	13-12, 13-13
XOW	13-6, 13-7

