

INTROCUCTION

The S1A0426C02 is a monolithic integrated circuit designed for radio cassette tape recorders, clock radios and headphone radios.

FUNCTIONS

- AM/FM RF AMP
- AM AGO Control
- Audio Power AMP
- DC Volume
- FM Quadrature DET
- AUDIO MUTE
- Local OSC
- FM AFO Control
- Tuning Indicator
- AM/FM IF AMP
- AM DET

FEATURES

- Built-in AM/FM Switching Circuit
- Wide operating supply voltage: $V_{CC} = 2V - 8.5V$
- Low current consumption ($V_{CC} = 3V$)
 - FM: $I_{CCQ} = 5.3 \text{ mA (Typ)}$
 - AM: $I_{CCQ} = 3.4 \text{ mA (Typ)}$
- High Power Audio Amplifier: 0.5W (typ) at $V_{CC} = 6V$,
- $RL = 8\Omega$, THD = 10%

ORDERING INFORMATION

Device	Package	Operating Temperature
S1A0426C02-A0B0	30-SDIP-400	-20°C - +70°C
S1A0426C02-S0B0	28-SOP-375	-20°C - +70°C

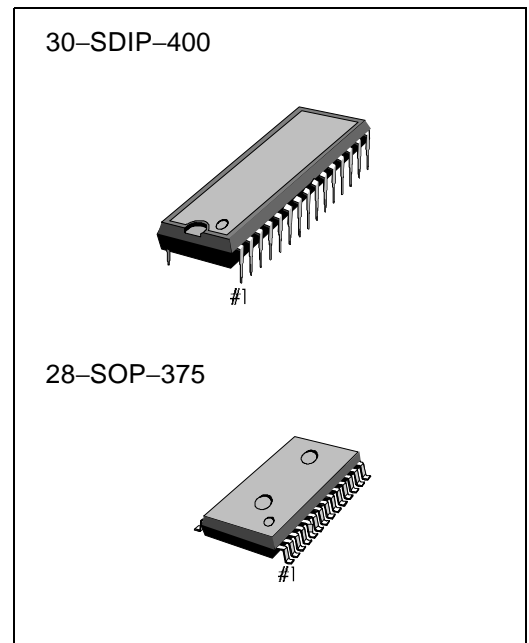

BLOCK DIAGRAM

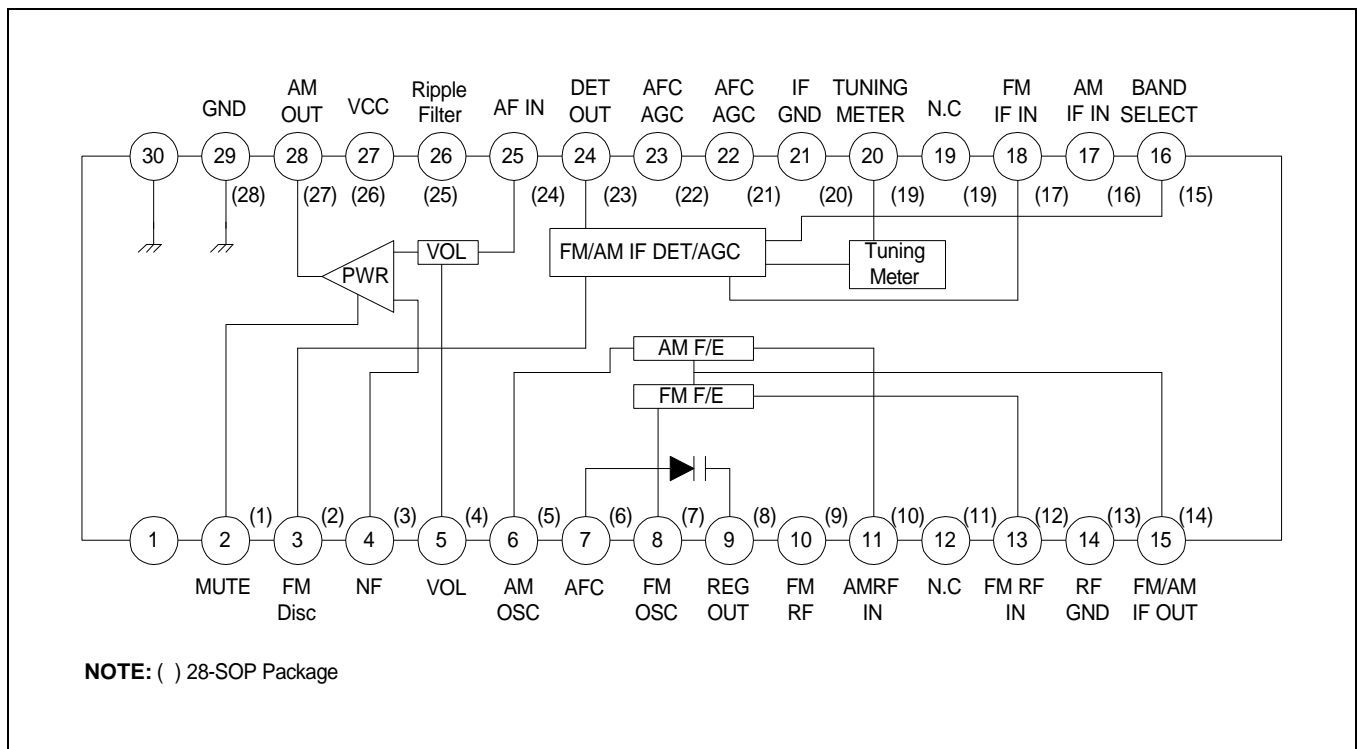

ABSOLUTE MAXIMUM RATINGS (Ta = 25°C)

Characteristic	Symbol	Value	Unit
Supply Voltage	V _{CC}	9	V
Power Dissipation	P _D	1000	mW
Operating Temperature	T _{OPR}	-20 – +70	°C
Storage Temperature	T _{STG}	-40 – +125	°C

ELECTRICAL CHARACTERISTICS

($V_{CC} = 6\text{ V}$, $T_a = 25\text{ }^\circ\text{C}$, FM; $\Delta f = 22.5\text{ kHz}$, $f_m = 1\text{ kHz}$, AM; 30% Mod, unless otherwise specified)

	Characteristic	Symbol	Test Conditions	Min.	Typ.	Max.	Unit
FM	Quiescent Circuit Current	$I_{CCQ(1)}$	$V_I = 0$	–	7.0	14.0	mA
	F/E Voltage Gain	$G_V(1)$	$V_I(1) = 40\text{dB}\mu$, $f_c = 100\text{MHz}$, $\Delta f = 0$	32	39	46	$\text{dB}\mu$
	Detect Output Gain	$V_O(1)$	$V_I(3) = 90\text{dB}\mu$, $f_i = 10.7\text{MHz}$	–26	–20	–14	dBm
	IF-3 dB Sensitivity	$V_{I(LIM)}$	$V_O(VI3) = 90\text{dB}\mu$, -3dB , $f_i = 10.7\text{MHz}$	–	24	32	dB
	Total Harmonic Distortion	THD_1	$V_I(3) = 90\text{dB}\mu$, $f_i = 10.7\text{MHz}$ ($\Delta f = 75\text{kHz}$)	–	0.3	2.0	%
	Meter Drive Current	$I_M(1)$	$V_I(3) = 60\text{dB}\mu$, $f_i = 10.7\text{MHz}$	1.8	3.5	7.0	mA
AM	Quiescent Circuit Current	$I_{CCQ(2)}$	$V_I = 0$	–	3.5	10.0	mA
	F/E Voltage Gain	$G_V(2)$	$V_I(2) = 60\text{dB}\mu$, $f_c = 1660\text{kHz}$, $m = 0\%$	15	22	29	dB
	IF Voltage Gain	$G_V(3)$	$V_O(3) = -34\text{dBm}$, $f_i = 455\text{kHz}$	14	20	27	$\text{dB}\mu$
	AM Detect Output Voltage	$V_O(2)$	$V_I(3) = 85\text{dB}\mu$, $f_i = 455\text{kHz}$	–26	–20	–14	dBm
	Total Harmonic Distortion	THD_2	$V_I(2) = 95\text{dB}\mu$, $f_c = 1660\text{kHz}$, $V_{CC} = 7.8\text{V}$	–	0.6	2.0	%
	Meter Drive Current	$I_M(2)$	$V_I(3) = 85\text{dB}\mu$, $f_i = 455\text{kHz}$	1.3	3.0	7.0	mA
AF	Closed Loop Voltage Gain	$G_V(4)$	$V_O(4) = 0\text{dBm}$, $f = 1\text{kHz}$	27	31.5	36	dB
	Total Harmonic Distortion	THD_3	$P_o = 50\text{mW}$, $f = 1\text{kHz}$	–	0.3	2.5	%
	Output Power	P_O	$R_L = 8\Omega$, $THD = 10\%$, $f = 1\text{kHz}$	0.4	0.5	–	W
	Mute Level	M_L	$P_o = \text{mW}$, $V_i(4) = 30\text{dBm}$ 1kHz , $V_1(3) = \text{FF}$	8	15	22	dB

APPLICATION CIRCUIT

