

## INTROCUCTION

The KA22425D is a monolithic integrated circuit designed for radio cassette tape recorders, clock radios and headphone radios.

## FUNCTIONS

- AM/FM RF AMP
- AM AGO Control
- Audio Power AMP
- DC Volume
- FM Quadrature DET
- AUDIO MUTE
- Local OSC
- FM AFO Control
- Tuning Indicator
- AM/FM IF AMP
- AM DET

## FEATURES

- Built-in AM/FM Switching Circuit
- Wide operating supply voltage:  $V_{CC} = 2V \sim 7.5V$
- Low current consumption ( $V_{CC} = 3V$ )
  - FM:  $I_{CCQ} = 5.3mA$  (Typ)
  - AM:  $I_{CCQ} = 3.4mA$  (Typ)
- High power audio amplifier: 0.5W(Typ) at  $V_{CC} = 6V$ ,
- $R_L = 8\Omega$ , THD = 10 %

## ORDERING INFORMATION

Device	Package	Operating Temperature
KA22425D	28-SOP-375	-20°C ~ +70°C

28-SOP-375

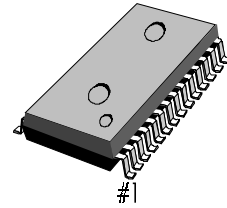

## BLOCK DIAGRAM

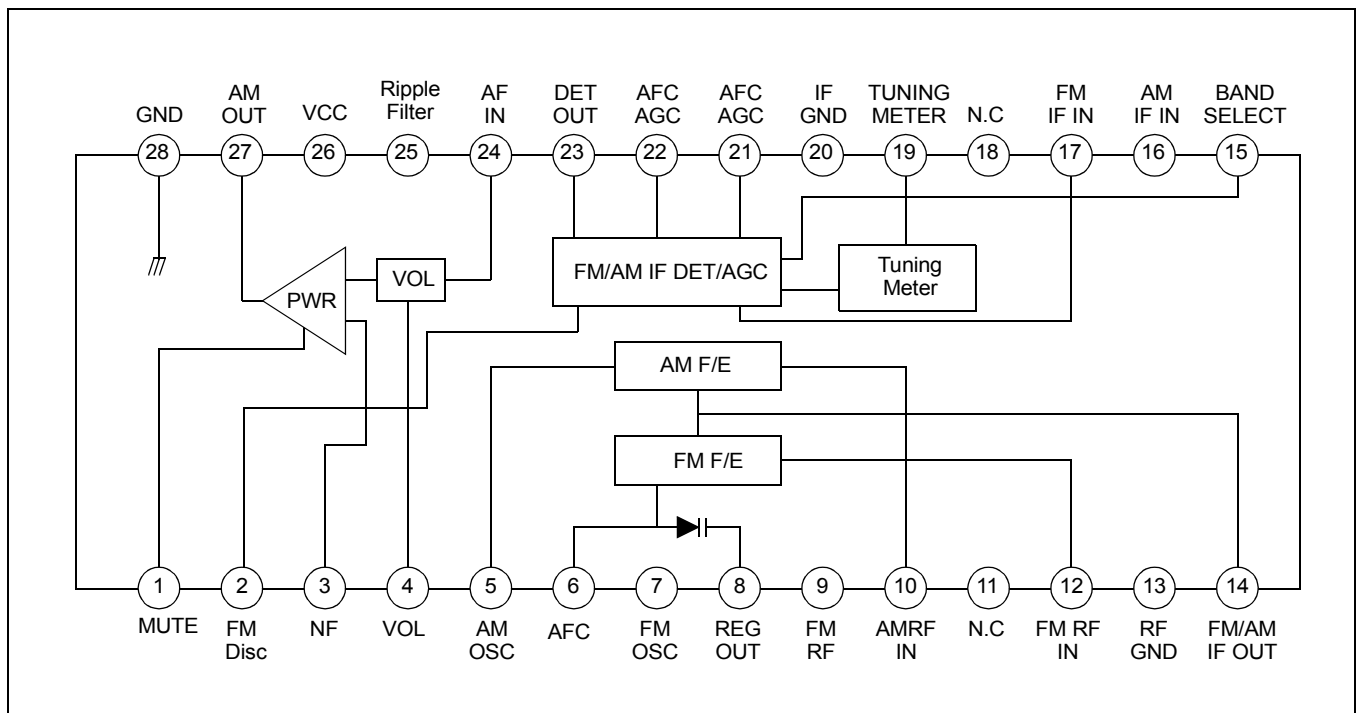

Figure 1.

## ABSOLUTE MAXIMUM RATINGS (Ta = 25°C)

Characteristic	Symbol	Value	Unit
Supply Voltage	V <sub>CC</sub>	9	V
Power Dissipation	P <sub>D</sub>	1000	mW
Operating Temperature	T <sub>OPR</sub>	-20 ~ +70	°C
Storage Temperature	T <sub>STG</sub>	-40 ~ +125	°C

## ELECTRICAL CHARACTERISTICS

(V<sub>CC</sub> = 6V, Ta = 25°C, FM; Δf = 22.5kHz, fm = 1kHz, AM; 30% Mod, unless otherwise specified)

	Characteristic	Symbol	Test Conditions	Min.	Typ.	Max.	Unit
FM	Quiescent Circuit Current	I <sub>CCQ</sub> (1)	V <sub>i</sub> = 0	–	7.0	14.0	mA
	F/E Voltage Gain	G <sub>V</sub> (1)	V <sub>i</sub> (1) = 40dBμ, f <sub>c</sub> = 100MHz, f = 0	32	39	46	dB
	Detect Output Gain	V <sub>O</sub> (1)	V <sub>i</sub> (3) = 90dBμ, f <sub>i</sub> = 10.7MHz	–26	–20	–14	dBm
	IF-3 dB Sensitivity	V <sub>I(LIM)</sub>	V <sub>O</sub> (V <sub>I3</sub> ) = 90dBμ –3dB, f <sub>i</sub> = 10.7MHz	–	24	32	dBμ
	Total Harmonic Distortion	THD <sub>1</sub>	V <sub>i</sub> (3) = 90dBμ, f <sub>i</sub> = 10.7MHz(Δf = 75kHz)	–	0.3	2.0	%
	Meter Drive Current	I <sub>M</sub> (1)	V <sub>i</sub> (3) = 60dBμ, f <sub>i</sub> = 10.7MHz	1.8	3.5	7.0	mA
AM	Quiescent Circuit Current	I <sub>CCQ</sub> (2)	V <sub>i</sub> = 0	–	3.5	10.0	mA
	F/E Voltage Gain	G <sub>V</sub> (2)	V <sub>i</sub> (2) = 60dBμ, f <sub>c</sub> = 1660kHz, m = 0%	15	22	29	dB
	IF Voltage Gain	G <sub>V</sub> (3)	V <sub>O</sub> (3) = –34dBm, f <sub>i</sub> = 455kHz	14	20	27	dBμ
	AM Detect Output Voltage	V <sub>O</sub> (2)	V <sub>i</sub> (3) = 85dBμ, f <sub>i</sub> = 455kHz	–26	–20	–14	dBm
	Total Harmonic Distortion	THD <sub>2</sub>	V <sub>i</sub> (2) = 95dBμ, f <sub>c</sub> = 1660kHz, V <sub>CC</sub> =7.8V	–	0.6	2.0	%
	Meter Drive Current	I <sub>M</sub> (2)	V <sub>i</sub> (3) = 85dBμ, f <sub>i</sub> = 455kHz	1.3	3.0	7.0	mA
AF	Closed Loop Voltage Gain	G <sub>V</sub> (4)	V <sub>O</sub> (4) = 0dBm, f = 1kHz	27	31.5	36	dB
	Total Harmonic Distortion	THD <sub>3</sub>	P <sub>O</sub> = 50mW, f = 1kHz	–	0.3	2.5	%
	Output Power	P <sub>O</sub>	R <sub>L</sub> = 8Ω, THD = 10%, f = 1kHz	0.4	0.5	–	W
	Mute Level	M <sub>L</sub>	P <sub>O</sub> = mW, V <sub>i</sub> (4) = 30dBm 1kHz, V <sub>i</sub> (3) = FF	8	15	22	dB

APPLICATION CIRCUIT

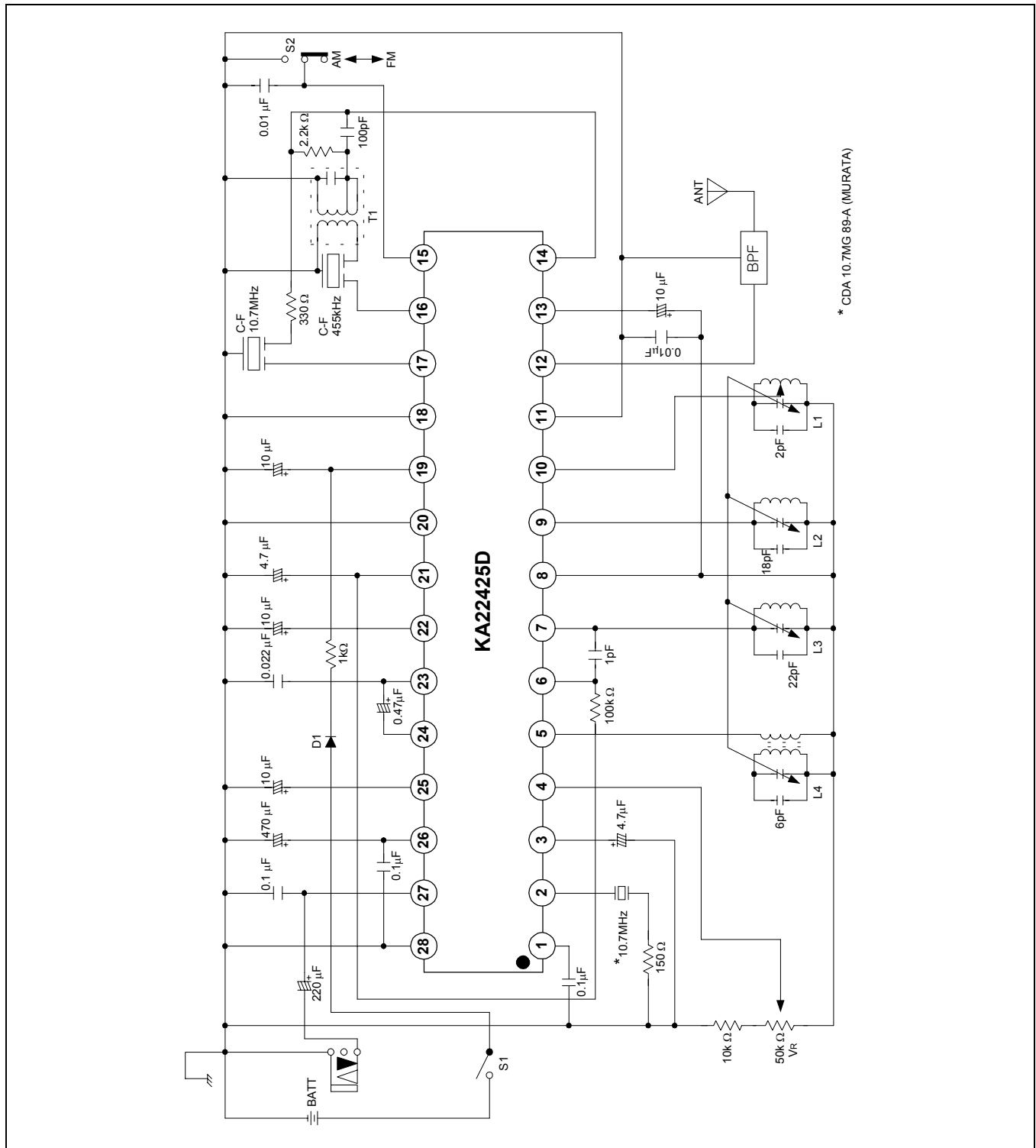

Figure 2.

This datasheet has been download from:

[www.datasheetcatalog.com](http://www.datasheetcatalog.com)

Datasheets for electronics components.