

PCA82C250

CAN controller interface

Rev. 06 — 26 March 2009

Product data sheet

1. General description

The PCA82C250 is the interface between a CAN protocol controller and the physical bus. The device provides differential transmit capability to the bus and differential receive capability to the CAN controller.

2. Features

- Fully compatible with the "ISO 11898" standard
- High speed (up to 1 MBd)
- Bus lines protected against transients in an automotive environment
- Slope control to reduce Radio Frequency Interference (RFI)
- Differential receiver with wide common-mode range for high immunity against ElectroMagnetic Interference (EMI)
- Thermally protected
- Short-circuit proof to battery and ground
- Low-current Standby mode
- An unpowered node does not disturb the bus lines
- At least 110 nodes can be connected

3. Applications

- High-speed automotive applications (up to 1 MBd).

4. Quick reference data

Table 1. Quick reference data

Symbol	Parameter	Conditions	Min	Max	Unit
V _{CC}	supply voltage		4.5	5.5	V
I _{CC}	supply current	Standby mode	-	170	μA
1/t _{bit}	maximum transmission speed	non-return-to-zero	1	-	MBd
V _{CAN}	CANH, CANL input/output voltage		-8	+18	V
V _{diff}	differential bus voltage		1.5	3.0	V
t _{PD}	propagation delay	High-speed mode	-	50	ns
T _{amb}	ambient temperature		-40	+125	°C

5. Ordering information

Table 2. Ordering information

Type number	Package		Version
	Name	Description	
PCA82C250T	SO8	plastic small outline package; 8 leads; body width 3.9 mm	SOT96-1

6. Block diagram

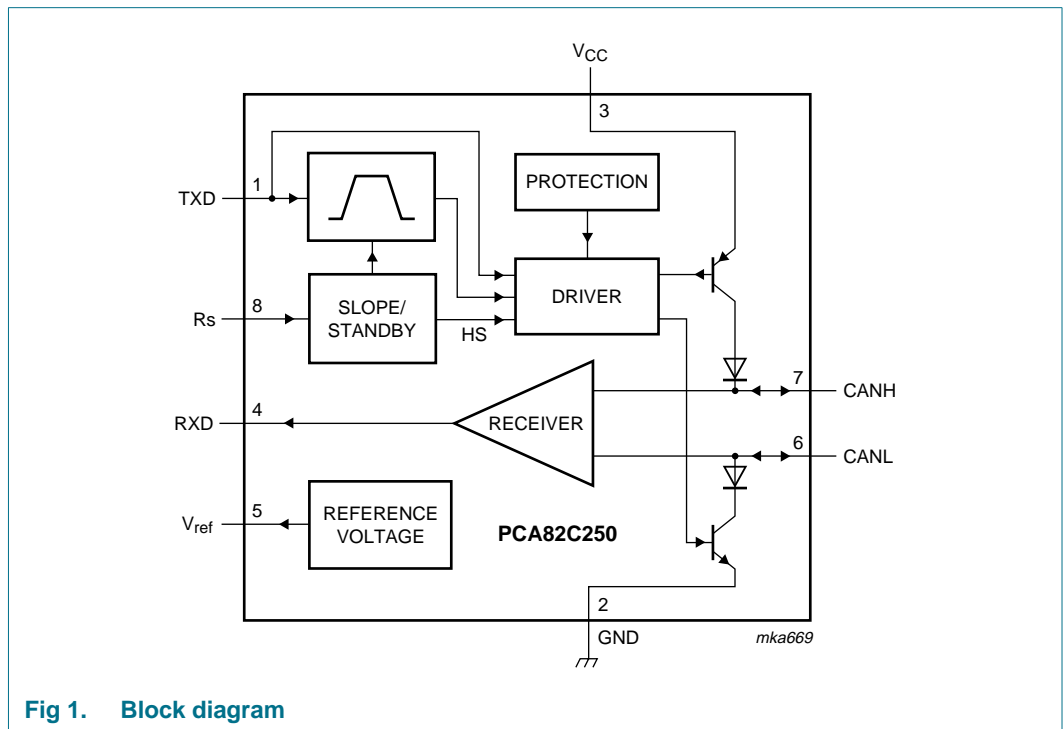

7. Pinning information

7.1 Pinning

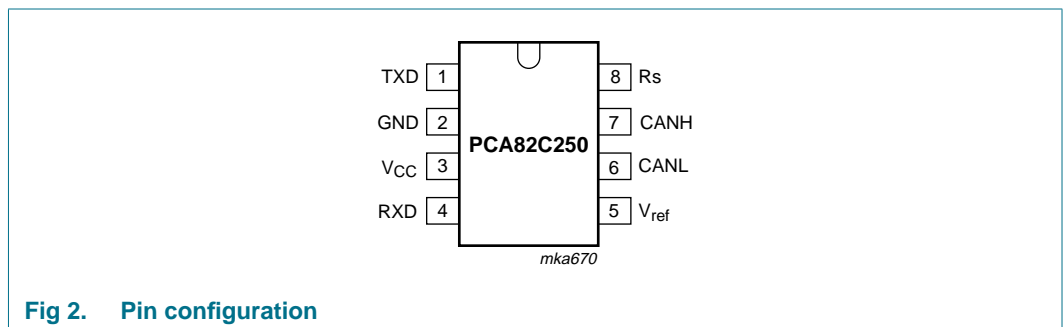

7.2 Pin description

Table 3. Pin description

Symbol	Pin	Description
TXD	1	transmit data input
GND	2	ground
V _{CC}	3	supply voltage
RXD	4	receive data output
V _{ref}	5	reference voltage output
CANL	6	LOW-level CAN voltage input/output
CANH	7	HIGH-level CAN voltage input/output
Rs	8	slope resistor input

8. Functional description

The PCA82C250 is the interface between a CAN protocol controller and the physical bus. It is primarily intended for high-speed automotive applications (up to 1 MBd). The device provides differential transmit capability to the bus and differential receive capability to the CAN controller. It is fully compatible with the "ISO 11898" standard.

A current limiting circuit protects the transmitter output stage against short-circuit to positive and negative battery voltage. Although the power dissipation is increased during this fault condition, this feature will prevent destruction of the transmitter output stage.

If the junction temperature exceeds a value of approximately 160 °C, the limiting current of both transmitter outputs is decreased. Because the transmitter is responsible for the major part of the power dissipation, this will result in reduced power dissipation and hence a lower chip temperature. All other parts of the PCA82C250 will remain in operation. The thermal protection is needed, in particular, when a bus line is short-circuited.

The CANH and CANL lines are also protected against electrical transients which may occur in an automotive environment.

Pin 8 (Rs) allows three different modes of operation to be selected: High-speed, Slope control and Standby.

For high-speed operation, the transmitter output transistors are simply switched on and off as fast as possible. In this mode, no measures are taken to limit the rise and fall slope. Use of a shielded cable is recommended to avoid RFI problems. The High-speed mode is selected by connecting pin 8 to ground.

For lower speeds or shorter bus length, an unshielded twisted pair or a parallel pair of wires can be used for the bus. To reduce RFI, the rise and fall slope should be limited. The rise and fall slope can be programmed with a resistor connected from pin 8 to ground. The slope is proportional to the current output at pin 8.

If a HIGH level is applied to pin 8, the circuit enters a low-current Standby mode. In this mode, the transmitter is switched off and the receiver is switched to a low current. If dominant bits are detected (differential bus voltage >0.9 V), RXD will be switched to a

LOW level. The microcontroller should react to this condition by switching the transceiver back to normal operation (via pin 8). Because the receiver is slow in Standby mode, the first message will be lost.

Table 4. Truth table of the CAN transceiver

Supply	TXD	CANH	CANL	Bus state	RXD
4.5 V to 5.5 V	0	HIGH	LOW	dominant	0
4.5 V to 5.5 V	1 (or floating)	floating	floating	recessive	1
< 2 V (not powered)	X ^[1]	floating	floating	recessive	X ^[1]
2 V < V _{CC} < 4.5 V	>0.75V _{CC}	floating	floating	recessive	X ^[1]
2 V < V _{CC} < 4.5 V	X ^[1]	floating if V _{Rs} > 0.75V _{CC}	floating if V _{Rs} > 0.75V _{CC}	recessive	X ^[1]

[1] X = don't care.

Table 5. Pin Rs summary

Condition forced at pin Rs	Mode	Resulting voltage or current at pin Rs
V _{Rs} > 0.75V _{CC}	Standby	I _{Rs} < 10 μA
-10 μA < I _{Rs} < -200 μA	Slope control	0.4V _{CC} < V _{Rs} < 0.6V _{CC}
V _{Rs} < 0.3V _{CC}	High-speed	I _{Rs} < -500 μA

9. Limiting values

Table 6. Limiting values

In accordance with the Absolute Maximum Rating System (IEC 60134). All voltages are referenced to pin 2; positive input current.

Symbol	Parameter	Conditions	Min	Max	Unit
V _{CC}	supply voltage		-0.3	+9.0	V
V _n	DC voltage at pins 1, 4, 5 and 8		-0.3	V _{CC} + 0.3	V
V _{6, 7}	DC voltage at pins 6 and 7	0 V < V _{CC} < 5.5 V; no time limit	-8.0	+18.0	V
V _{trt}	transient voltage at pins 6 and 7	see Figure 8	-150	+100	V
T _{stg}	storage temperature		-55	+150	°C
T _{amb}	ambient temperature		-40	+125	°C
T _{vj}	virtual junction temperature		^[1] -40	+150	°C
V _{esd}	electrostatic discharge voltage		^[2] -2000	+2000	V
			^[3] -200	+200	V

[1] In accordance with "IEC 60747-1". An alternative definition of virtual junction temperature is: T_{vj} = T_{amb} + P_d × R_{th(j-a)}, where R_{th(j-a)} is a fixed value to be used for the calculation of T_{vj}. The rating for T_{vj} limits the allowable combinations of power dissipation (P_d) and ambient temperature (T_{amb}).

[2] Classification A: human body model; C = 100 pF; R = 1500 Ω; V = ±2000 V.

[3] Classification B: machine model; C = 200 pF; R = 25 Ω; V = ±200 V.

10. Thermal characteristics

Table 7. Thermal characteristics

Symbol	Parameter	Conditions	Typ	Unit
$R_{th(j-a)}$	thermal resistance from junction to ambient	in free air	160	K/W

11. Characteristics

Table 8. Characteristics

$V_{CC} = 4.5$ to 5.5 V; $T_{amb} = -40$ to $+125$ °C; $R_L = 60$ Ω; $I_B > -10$ μA; unless otherwise specified; all voltages referenced to ground (pin 2); positive input current; all parameters are guaranteed over the ambient temperature range by design, but only 100 % tested at $+25$ °C.

Symbol	Parameter	Conditions	Min	Typ	Max	Unit
Supply						
I_3	supply current	dominant; $V_1 = 1$ V	-	-	70	mA
		recessive; $V_1 = 4$ V; $R_8 = 47$ kΩ	-	-	14	mA
		recessive; $V_1 = 4$ V; $V_8 = 1$ V	-	-	18	mA
		Standby; $T_{amb} < 90$ °C	[1]	-	100	170
DC bus transmitter						
V_{IH}	HIGH-level input voltage	output recessive	$0.7V_{CC}$	-	$V_{CC} + 0.3$	V
V_{IL}	LOW-level input voltage	output dominant	-0.3	-	$0.3V_{CC}$	V
I_{IH}	HIGH-level input current	$V_1 = 4$ V	-200	-	+30	μA
I_{IL}	LOW-level input current	$V_1 = 1$ V	-100	-	-600	μA
$V_{6,7}$	recessive bus voltage	$V_1 = 4$ V; no load	2.0	-	3.0	V
I_{LO}	off-state output leakage current	-2 V < (V_6, V_7) < 7 V	-2	-	+1	mA
		-5 V < (V_6, V_7) < 18 V	-5	-	+12	mA
V_7	CANH output voltage	$V_1 = 1$ V	2.75	-	4.5	V
V_6	CANL output voltage	$V_1 = 1$ V	0.5	-	2.25	V
$\Delta V_{6,7}$	difference between output voltage at pins 6 and 7	$V_1 = 1$ V	1.5	-	3.0	V
		$V_1 = 1$ V; $R_L = 45$ Ω; $V_{CC} \geq 4.9$ V	1.5	-	-	V
		$V_1 = 4$ V; no load	-500	-	+50	mV
I_{sc7}	short-circuit CANH current	$V_7 = -5$ V; $V_{CC} \leq 5$ V	-	-	-105	mA
		$V_7 = -5$ V; $V_{CC} = 5.5$ V	-	-	-120	mA
I_{sc6}	short-circuit CANL current	$V_6 = 18$ V	-	-	160	mA
DC bus receiver: $V_1 = 4$ V; pins 6 and 7 externally driven; -2 V < (V_6, V_7) < 7 V; unless otherwise specified						
$V_{diff(r)}$	differential input voltage (recessive)		-1.0	-	+0.5	V
		-7 V < (V_6, V_7) < 12 V; not Standby mode	-1.0	-	+0.4	V
$V_{diff(d)}$	differential input voltage (dominant)		0.9	-	5.0	V
		-7 V < (V_6, V_7) < 12 V; not Standby mode	1.0	-	5.0	V
$V_{diff(hys)}$	differential input hysteresis	see Figure 5	-	150	-	mV
V_{OH}	HIGH-level output voltage	pin 4; $I_4 = -100$ μA	$0.8V_{CC}$	-	V_{CC}	V

Table 8. Characteristics ...continued

$V_{CC} = 4.5$ to 5.5 V; $T_{amb} = -40$ to $+125$ °C; $R_L = 60$ Ω; $I_8 > -10$ μA; unless otherwise specified; all voltages referenced to ground (pin 2); positive input current; all parameters are guaranteed over the ambient temperature range by design, but only 100 % tested at $+25$ °C.

Symbol	Parameter	Conditions	Min	Typ	Max	Unit
V_{OL}	LOW-level output voltage	pin 4; $I_4 = 1$ mA	0	-	$0.2V_{CC}$	V
		$I_4 = 10$ mA	0	-	1.5	V
R_i	input resistance	CANH, CANL	5	-	25	kΩ
R_{diff}	differential input resistance		20	-	100	kΩ
C_i	input capacitance	CANH, CANL	-	-	20	pF
C_{diff}	differential input capacitance		-	-	10	pF
Reference output						
V_{ref}	reference output voltage	$V_8 = 1$ V; -50 μA $< I_5 < 50$ μA	$0.45V_{CC}$	-	$0.55V_{CC}$	V
		$V_8 = 4$ V; -5 μA $< I_5 < 5$ μA	$0.4V_{CC}$	-	$0.6V_{CC}$	V
Timing (see Figure 4, Figure 6 and Figure 7)						
t_{bit}	bit time	minimum; $V_8 = 1$ V	-	-	1	μs
t_{onTXD}	delay TXD to bus active	$V_8 = 1$ V	-	-	50	ns
t_{offTXD}	delay TXD to bus inactive	$V_8 = 1$ V	-	40	80	ns
t_{onRXD}	delay TXD to receiver active	$V_8 = 1$ V	-	55	120	ns
t_{offRXD}	delay TXD to receiver inactive	$V_8 = 1$ V; $V_{CC} < 5.1$ V; $T_{amb} < +85$ °C	-	82	150	ns
		$V_8 = 1$ V; $V_{CC} < 5.1$ V; $T_{amb} < +125$ °C	-	82	170	ns
		$V_8 = 1$ V; $V_{CC} < 5.5$ V; $T_{amb} < +85$ °C	-	90	170	ns
		$V_8 = 1$ V; $V_{CC} < 5.5$ V; $T_{amb} < +125$ °C	-	90	190	ns
t_{onRXD}	delay TXD to receiver active	$R_8 = 47$ kΩ	-	390	520	ns
		$R_8 = 24$ kΩ	-	260	320	ns
t_{offRXD}	delay TXD to receiver inactive	$R_8 = 47$ kΩ	-	260	450	ns
		$R_8 = 24$ kΩ	-	210	320	ns
$ SR $	differential output voltage slew rate	$R_8 = 47$ kΩ	-	14	-	V/μs
t_{WAKE}	wake-up time from standby	via pin 8	-	-	20	μs
t_{dRXDL}	bus dominant to RXD LOW	$V_8 = 4$ V; Standby mode	-	-	3	μs
Standby/Slope Control (pin 8)						
V_8	input voltage for high-speed		-	-	$0.3V_{CC}$	V
I_8	input current for high-speed	$V_8 = 0$ V	-	-	-500	μA
V_{stb}	input voltage for standby mode		$0.75V_{CC}$	-	-	V
I_{slope}	slope control mode current		-10	-	-200	μA
V_{slope}	slope control mode voltage		$0.4V_{CC}$	-	$0.6V_{CC}$	V

[1] $I_1 = I_4 = I_5 = 0$ mA; 0 V $< V_6 < V_{CC}$; 0 V $< V_7 < V_{CC}$; $V_8 = V_{CC}$.

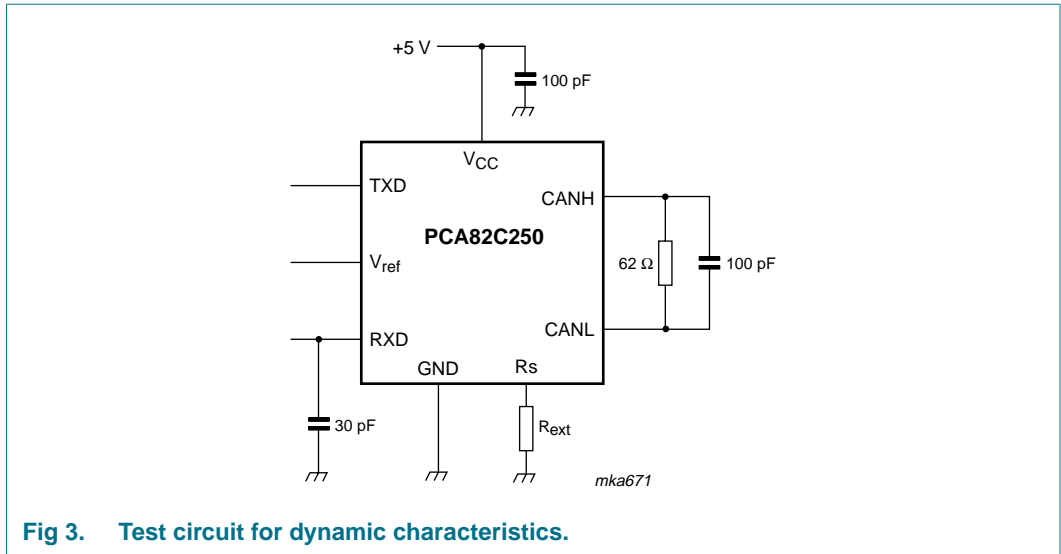

Fig 3. Test circuit for dynamic characteristics.

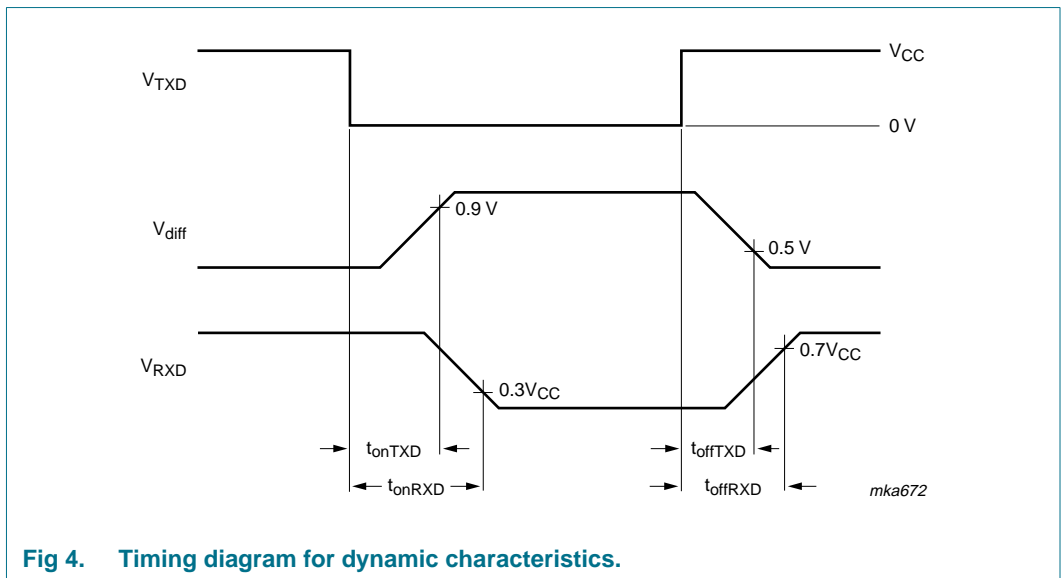

Fig 4. Timing diagram for dynamic characteristics.

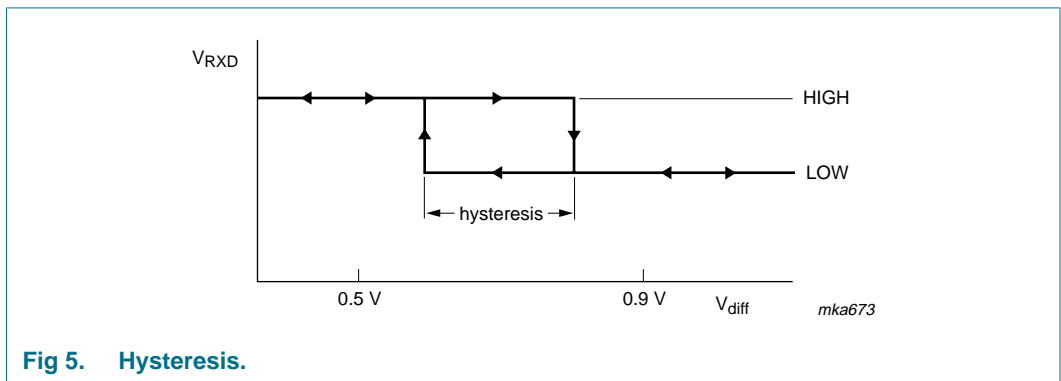
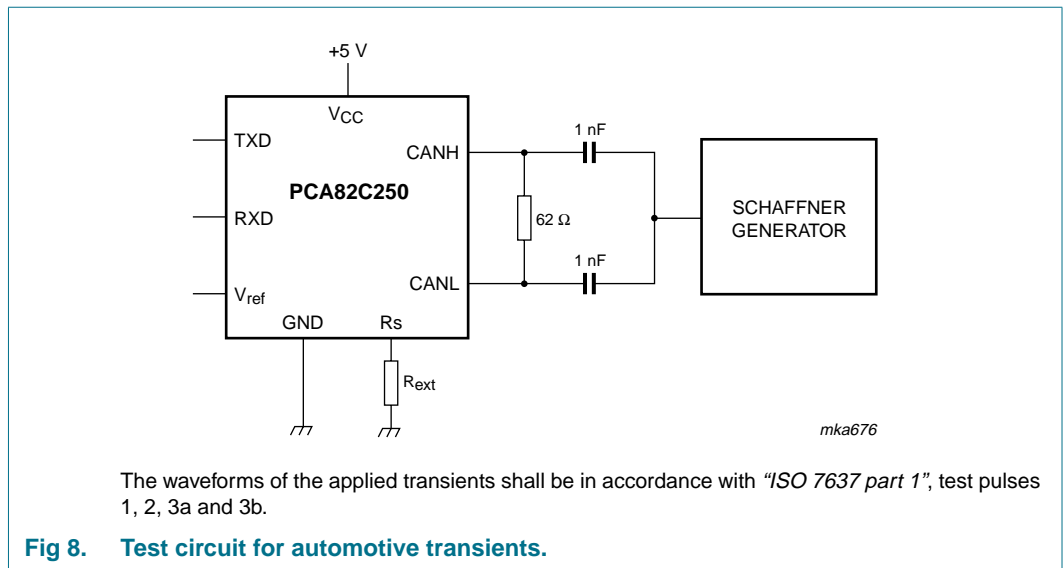
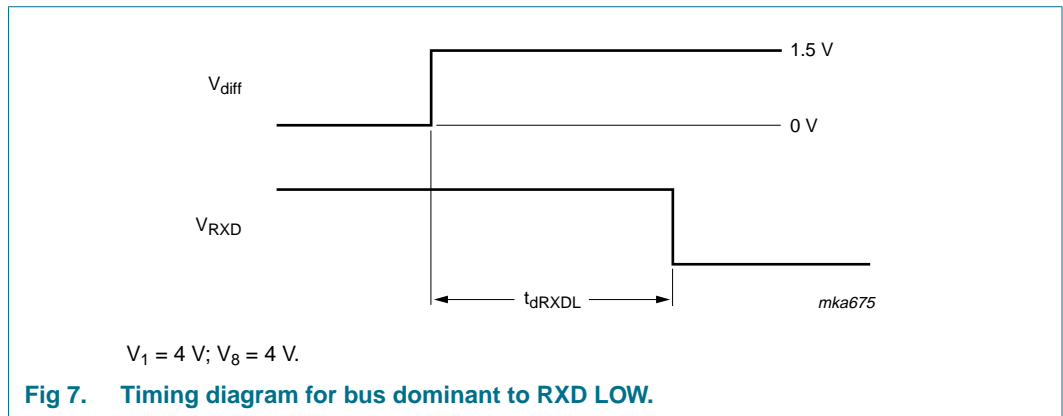
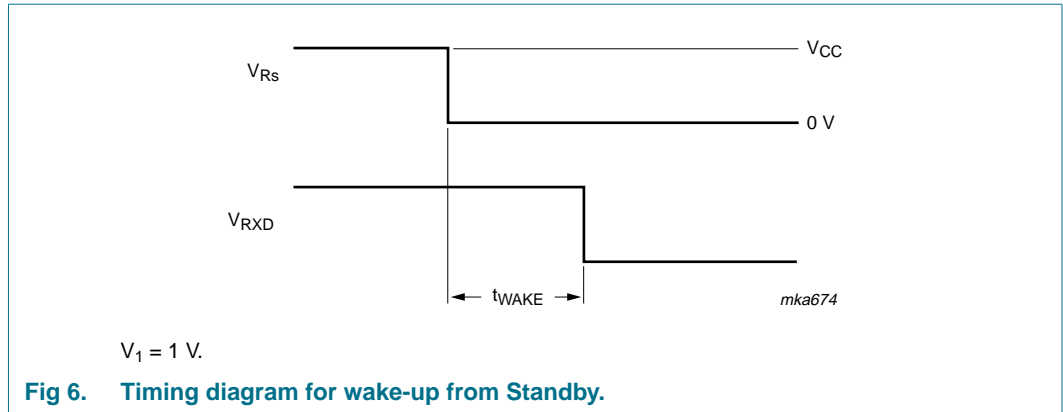

Fig 5. Hysteresis.



12. Application information

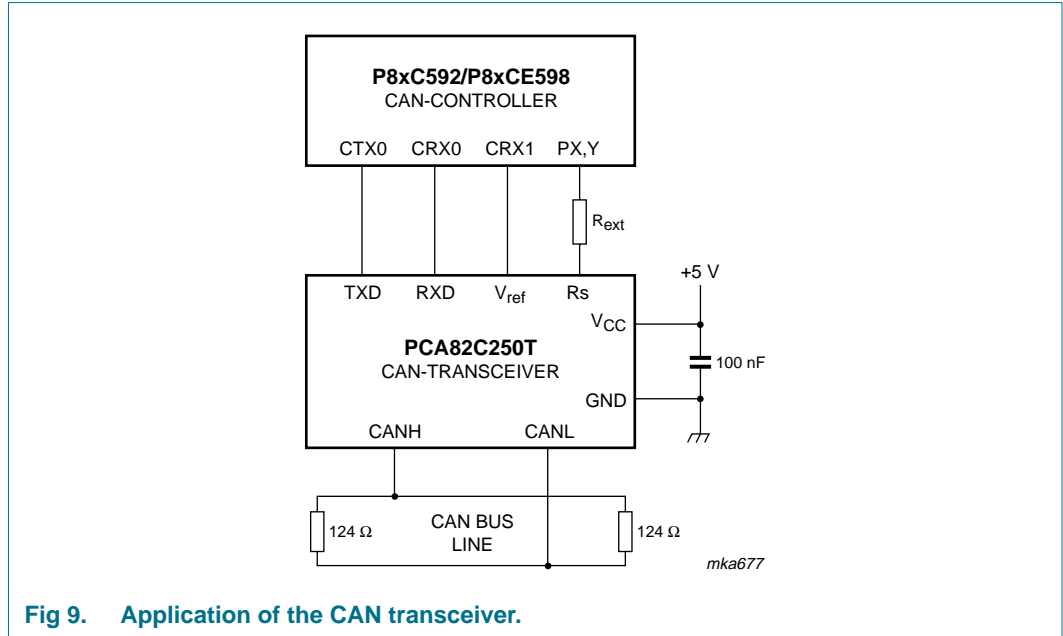

Fig 9. Application of the CAN transceiver.

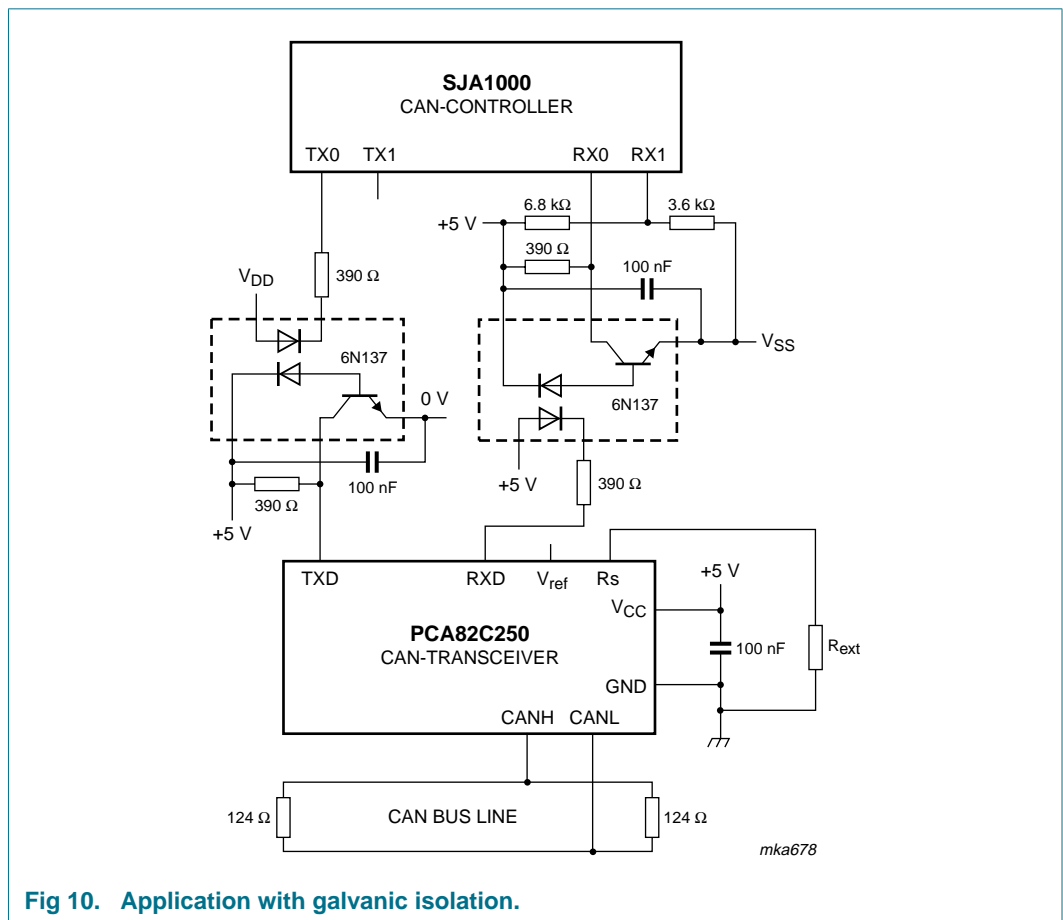

Fig 10. Application with galvanic isolation.

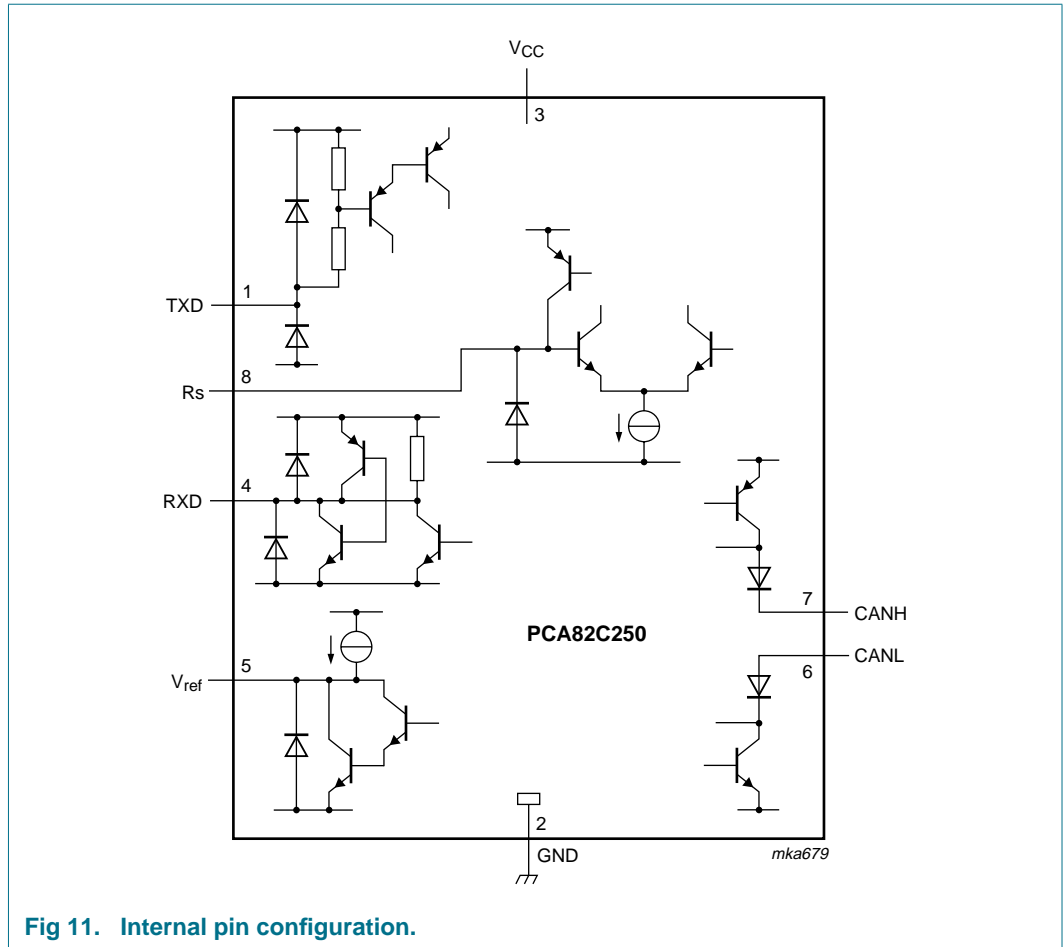

Fig 11. Internal pin configuration.

13. Package outline

SO8: plastic small outline package; 8 leads; body width 3.9 mm

SOT96-1

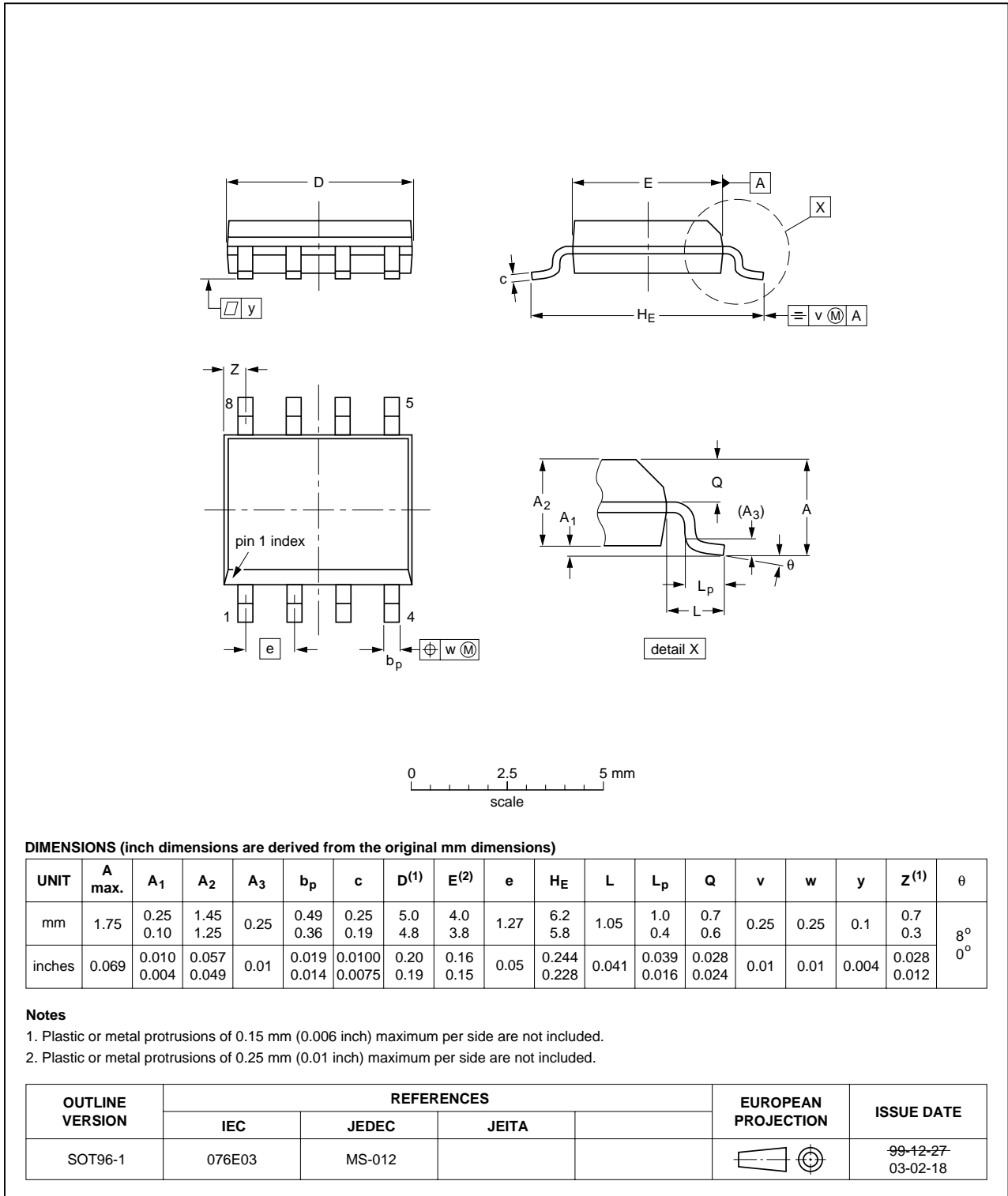

Fig 12. Package outline SOT96-1 (SO8)

14. Soldering of SMD packages

This text provides a very brief insight into a complex technology. A more in-depth account of soldering ICs can be found in Application Note *AN10365 "Surface mount reflow soldering description"*.

14.1 Introduction to soldering

Soldering is one of the most common methods through which packages are attached to Printed Circuit Boards (PCBs), to form electrical circuits. The soldered joint provides both the mechanical and the electrical connection. There is no single soldering method that is ideal for all IC packages. Wave soldering is often preferred when through-hole and Surface Mount Devices (SMDs) are mixed on one printed wiring board; however, it is not suitable for fine pitch SMDs. Reflow soldering is ideal for the small pitches and high densities that come with increased miniaturization.

14.2 Wave and reflow soldering

Wave soldering is a joining technology in which the joints are made by solder coming from a standing wave of liquid solder. The wave soldering process is suitable for the following:

- Through-hole components
- Leaded or leadless SMDs, which are glued to the surface of the printed circuit board

Not all SMDs can be wave soldered. Packages with solder balls, and some leadless packages which have solder lands underneath the body, cannot be wave soldered. Also, leaded SMDs with leads having a pitch smaller than ~0.6 mm cannot be wave soldered, due to an increased probability of bridging.

The reflow soldering process involves applying solder paste to a board, followed by component placement and exposure to a temperature profile. Leaded packages, packages with solder balls, and leadless packages are all reflow solderable.

Key characteristics in both wave and reflow soldering are:

- Board specifications, including the board finish, solder masks and vias
- Package footprints, including solder thieves and orientation
- The moisture sensitivity level of the packages
- Package placement
- Inspection and repair
- Lead-free soldering versus SnPb soldering

14.3 Wave soldering

Key characteristics in wave soldering are:

- Process issues, such as application of adhesive and flux, clinching of leads, board transport, the solder wave parameters, and the time during which components are exposed to the wave
- Solder bath specifications, including temperature and impurities

14.4 Reflow soldering

Key characteristics in reflow soldering are:

- Lead-free versus SnPb soldering; note that a lead-free reflow process usually leads to higher minimum peak temperatures (see [Figure 13](#)) than a SnPb process, thus reducing the process window
- Solder paste printing issues including smearing, release, and adjusting the process window for a mix of large and small components on one board
- Reflow temperature profile; this profile includes preheat, reflow (in which the board is heated to the peak temperature) and cooling down. It is imperative that the peak temperature is high enough for the solder to make reliable solder joints (a solder paste characteristic). In addition, the peak temperature must be low enough that the packages and/or boards are not damaged. The peak temperature of the package depends on package thickness and volume and is classified in accordance with [Table 9](#) and [10](#)

Table 9. SnPb eutectic process (from J-STD-020C)

Package thickness (mm)	Package reflow temperature (°C)	
	Volume (mm ³)	
	< 350	≥ 350
< 2.5	235	220
≥ 2.5	220	220

Table 10. Lead-free process (from J-STD-020C)

Package thickness (mm)	Package reflow temperature (°C)		
	Volume (mm ³)		
	< 350	350 to 2000	> 2000
< 1.6	260	260	260
1.6 to 2.5	260	250	245
> 2.5	250	245	245

Moisture sensitivity precautions, as indicated on the packing, must be respected at all times.

Studies have shown that small packages reach higher temperatures during reflow soldering, see [Figure 13](#).

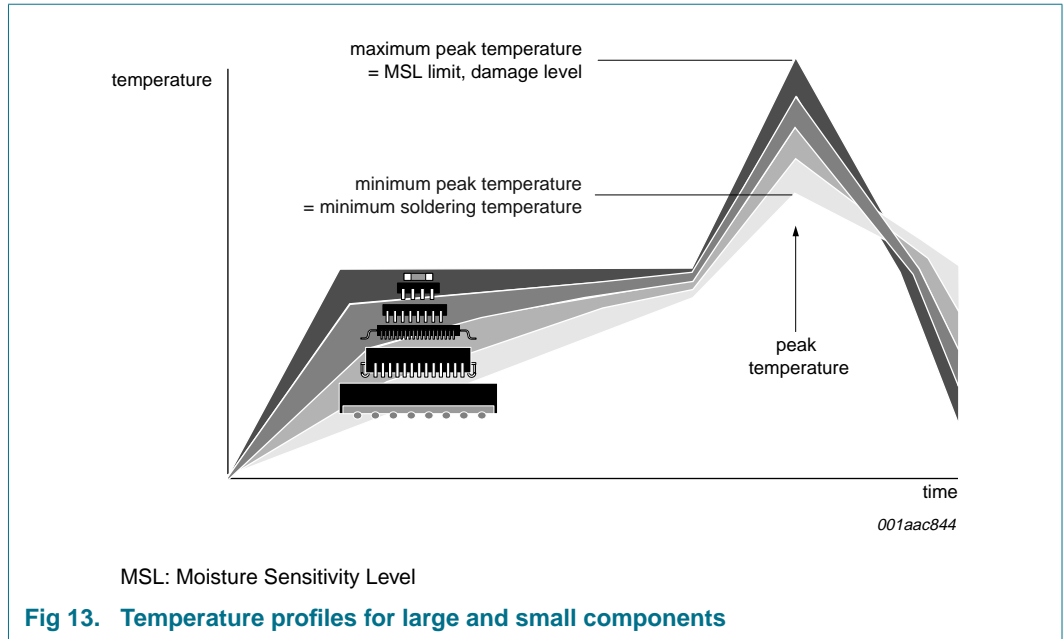

For further information on temperature profiles, refer to Application Note AN10365 "Surface mount reflow soldering description".

15. Revision history

Table 11. Revision history

Document ID	Release date	Data sheet status	Change notice	Supersedes
PCA82C250_6	20090326	Product data sheet	-	PCA82C250_5
Modifications:		<ul style="list-style-type: none">• The format of this data sheet has been redesigned to comply with the new identity guidelines of NXP Semiconductors.• Legal texts have been adapted to the new company name where appropriate.• DIP8 package discontinued; bare die no longer available.		
PCA82C250_5	20000113	Product specification	-	PCA82C250_3
PCA82C250_3	19971021	Preliminary specification		PCA82C250_2
PCA82C250_2	19940915	-		PCA82C250_1
PCA82C250_1	19940408	-		-

16. Legal information

16.1 Data sheet status

Document status ^{[1][2]}	Product status ^[3]	Definition
Objective [short] data sheet	Development	This document contains data from the objective specification for product development.
Preliminary [short] data sheet	Qualification	This document contains data from the preliminary specification.
Product [short] data sheet	Production	This document contains the product specification.

[1] Please consult the most recently issued document before initiating or completing a design.

[2] The term 'short data sheet' is explained in section "Definitions".

[3] The product status of device(s) described in this document may have changed since this document was published and may differ in case of multiple devices. The latest product status information is available on the Internet at URL <http://www.nxp.com>.

16.2 Definitions

Draft — The document is a draft version only. The content is still under internal review and subject to formal approval, which may result in modifications or additions. NXP Semiconductors does not give any representations or warranties as to the accuracy or completeness of information included herein and shall have no liability for the consequences of use of such information.

Short data sheet — A short data sheet is an extract from a full data sheet with the same product type number(s) and title. A short data sheet is intended for quick reference only and should not be relied upon to contain detailed and full information. For detailed and full information see the relevant full data sheet, which is available on request via the local NXP Semiconductors sales office. In case of any inconsistency or conflict with the short data sheet, the full data sheet shall prevail.

16.3 Disclaimers

General — Information in this document is believed to be accurate and reliable. However, NXP Semiconductors does not give any representations or warranties, expressed or implied, as to the accuracy or completeness of such information and shall have no liability for the consequences of use of such information.

Right to make changes — NXP Semiconductors reserves the right to make changes to information published in this document, including without limitation specifications and product descriptions, at any time and without notice. This document supersedes and replaces all information supplied prior to the publication hereof.

Suitability for use — NXP Semiconductors products are not designed, authorized or warranted to be suitable for use in medical, military, aircraft, space or life support equipment, nor in applications where failure or malfunction of an NXP Semiconductors product can reasonably be expected to result in personal injury, death or severe property or environmental

damage. NXP Semiconductors accepts no liability for inclusion and/or use of NXP Semiconductors products in such equipment or applications and therefore such inclusion and/or use is at the customer's own risk.

Applications — Applications that are described herein for any of these products are for illustrative purposes only. NXP Semiconductors makes no representation or warranty that such applications will be suitable for the specified use without further testing or modification.

Limiting values — Stress above one or more limiting values (as defined in the Absolute Maximum Ratings System of IEC 60134) may cause permanent damage to the device. Limiting values are stress ratings only and operation of the device at these or any other conditions above those given in the Characteristics sections of this document is not implied. Exposure to limiting values for extended periods may affect device reliability.

Terms and conditions of sale — NXP Semiconductors products are sold subject to the general terms and conditions of commercial sale, as published at <http://www.nxp.com/profile/terms>, including those pertaining to warranty, intellectual property rights infringement and limitation of liability, unless explicitly otherwise agreed to in writing by NXP Semiconductors. In case of any inconsistency or conflict between information in this document and such terms and conditions, the latter will prevail.

No offer to sell or license — Nothing in this document may be interpreted or construed as an offer to sell products that is open for acceptance or the grant, conveyance or implication of any license under any copyrights, patents or other industrial or intellectual property rights.

Export control — This document as well as the item(s) described herein may be subject to export control regulations. Export might require a prior authorization from national authorities.

Quick reference data — The Quick reference data is an extract of the product data given in the Limiting values and Characteristics sections of this document, and as such is not complete, exhaustive or legally binding.

16.4 Trademarks

Notice: All referenced brands, product names, service names and trademarks are the property of their respective owners.

17. Contact information

For more information, please visit: <http://www.nxp.com>

For sales office addresses, please send an email to: salesaddresses@nxp.com

18. Contents

1 General description 1

2 Features 1

3 Applications 1

4 Quick reference data 1

5 Ordering information 2

6 Block diagram 2

7 Pinning information 2

7.1 Pinning 2

7.2 Pin description 3

8 Functional description 3

9 Limiting values 4

10 Thermal characteristics 5

11 Characteristics 5

12 Application information 9

13 Package outline 11

14 Soldering of SMD packages 12

14.1 Introduction to soldering 12

14.2 Wave and reflow soldering 12

14.3 Wave soldering 12

14.4 Reflow soldering 13

15 Revision history 15

16 Legal information 16

16.1 Data sheet status 16

16.2 Definitions 16

16.3 Disclaimers 16

16.4 Trademarks 16

17 Contact information 16

18 Contents 17

Please be aware that important notices concerning this document and the product(s) described herein, have been included in section 'Legal information'.



© NXP B.V. 2009. **All rights reserved.**
 For more information, please visit: <http://www.nxp.com>
 For sales office addresses, please send an email to: salesaddresses@nxp.com
 Date of release: 26 March 2009
 Document identifier: PCA82C250_6



[Home](#) [About NXP](#) [News](#) [Careers](#) [Investors](#) [Order/buy](#) [Support](#) [Contact](#) [my.NXP](#)

Select site:

[Search](#)

[Advanced search / Selection guides](#)

Products ... [High-speed CAN transceivers](#) **PCA82C250T**

PCA82C250

[Preview](#) [Product information](#) [Selection guide](#)

Datasheet

 **PCA82C250**
(Product Specification)
26-Mar-09, 17 Pages, 93kB

[Download datasheet](#)
[Download all documentation](#)

PCA82C250 - CAN controller interface

- [General description](#)
- [Features](#)
- [Products/packages](#)
- [Quality/reliability/chemical content](#)
- [Pricing/ordering/availability](#)
- [Samples](#)
- [Discontinued information](#)
- [Applications](#)
- [Block diagrams/pinning](#)
- [Design support](#)
- [Parametrics/similar products](#)
- [Print/email](#)
- [Disclaimers](#)

All information hereunder is subject to the subsequent disclaimers

See also

- [See the answers to FAQ's on certain fields of interest](#)
- [Find NXP's equivalent of a competitor's part number](#)
- [View case studies on general applications or technologies](#)
- [Request contact with a technical expert](#)
- [Find more information on NXP's Vision](#)
- [Find out more about our ordering process](#)
- [Receive e-news on specific interest areas](#)

General description

[Hide](#)

The PCA82C250 is the interface between a CAN protocol controller and the physical bus. The device provides differential transmit capability to the bus and differential receive capability to the CAN controller.

[Back to top](#)

Features

[Hide](#)

- Fully compatible with the "ISO 11898" standard
- High speed (up to 1 MBd)
- Bus lines protected against transients in an automotive environment
- Slope control to reduce Radio Frequency Interference (RFI)
- Differential receiver with wide common-mode range for high immunity against ElectroMagnetic Interference (EMI)
- Thermally protected
- Short-circuit proof to battery and ground
- Low-current Standby mode
- An unpowered node does not disturb the bus lines
- At least 110 nodes can be connected

[Back to top](#)

Products/packages

[Hide](#)

Type number	Orderable part number	Ordering code (12NC)	Product status	Package	Packing	Marking	ECCN
PCA82C250T/YM	PCA82C250T/YM,112	9352 888 83112	Development	SOT96	Tube	Standard Marking	
PCA82C250T/YM	PCA82C250T/YM,115	9352 888 83115	Development	SOT96	Reel Pack, SMD, 7"	Standard Marking	
PCA82C250T/YM	PCA82C250T/YM,118	9352 888 83118	Development	SOT96	Reel Pack, SMD, 13"	Standard Marking	

The variants in the table below are discontinued. See the table [Discontinued information](#) for more information.

Type number	Orderable part number	Ordering code (12NC)	Product status	Package	Packing	Marking	ECCN
PCA82C250T/N4	PCA82C250T/N4,112	9350 853 30112	Discontinued Replacement product	SOT96	Tube	Standard Marking	
PCA82C250T/N4	PCA82C250T/N4,115	9350 853 30115	Discontinued Replacement product	SOT96	Reel Pack, SMD, 7"	Standard Marking	
PCA82C250T/N4	PCA82C250T/N4,118	9350 853 30118	Discontinued Replacement product	SOT96	Reel Pack, SMD, 13"	Standard Marking	









[Back to top](#)

Quality/reliability/chemical content

[Hide](#)

Type number	Orderable part number	Chemical content	RoHS	Leadfree conversion date	RHF	IFR (FIT)	MTBF (hours)	MSL
PCA82C250T/YM	PCA82C250T/YM,112	Not available	 	Always Pb-free				
PCA82C250T/YM	PCA82C250T/YM,115	Not available	 	Always Pb-free				
PCA82C250T/YM	PCA82C250T/YM,118	Not available	 	Always Pb-free				

The variants in the table below are discontinued. See the table [Discontinued information](#) for more information.

Type number	Orderable part number	Chemical content	RoHS	Leadfree conversion date	RHF	IFR (FIT)	MTBF (hours)	MSL
PCA82C250T/N4	PCA82C250T/N4,112	PCA82C250T_N4	 	week 3, 2005				
PCA82C250T/N4	PCA82C250T/N4,115	PCA82C250T_N4	 	week 3, 2005				
PCA82C250T/N4	PCA82C250T/N4,118	PCA82C250T_N4	 	week 3, 2005				

Quality and reliability disclaimer

[Back to top](#)

Pricing/ordering/availability

[Hide](#)

Type number	Ordering code (12NC)	Orderable part number	Indicative price/unit (\$)	Region	Distributor	In stock	Order quantity	Inventory date	Buy online	Samples
PCA82C250T/YM	9352 888 83112	PCA82C250T/YM,112								not available
PCA82C250T/YM	9352 888 83115	PCA82C250T/YM,115								not available
PCA82C250T/YM	9352 888 83118	PCA82C250T/YM,118								not available

[Back to top](#)

Discontinued information

[Hide](#)

Type number	Ordering code (12NC)	Last-time buy date	Last-time delivery date	Replacement product	DN Notice	Status	Comments

PCA82C250T/N4	935085330112	31-dec-09	31-mrt-12	PCA82C250T/YM	DN 64	Sole source product Limited availability (check with your usual sales contact)	FAB ICN5 Closure. Refer to PCN200901053A dated January 21, 2009. Extended Last Time Delivery to 31.3.2012. Replacement type with new diffusion fab location only
PCA82C250T/N4	935085330115	31-dec-09	31-mrt-12	PCA82C250T/YM	DN 64	Sole source product Limited availability (check with your usual sales contact)	FAB ICN5 Closure. Refer to PCN200901053A dated January 21, 2009. Extended Last Time Delivery to 31.3.2012. Replacement type with new diffusion fab location only
PCA82C250T/N4	935085330118	31-dec-09	31-mrt-12	PCA82C250T/YM	DN 64	Sole source product Limited availability (check with your usual sales contact)	FAB ICN5 Closure. Refer to PCN200901053A dated January 21, 2009. Extended Last Time Delivery to 31.3.2012. Replacement type with new diffusion fab location only

[Back to top](#)

Applications

[Hide](#)

High-speed automotive applications (up to 1 MBd).

[Back to top](#)

Block diagrams/pinning

[Hide](#)

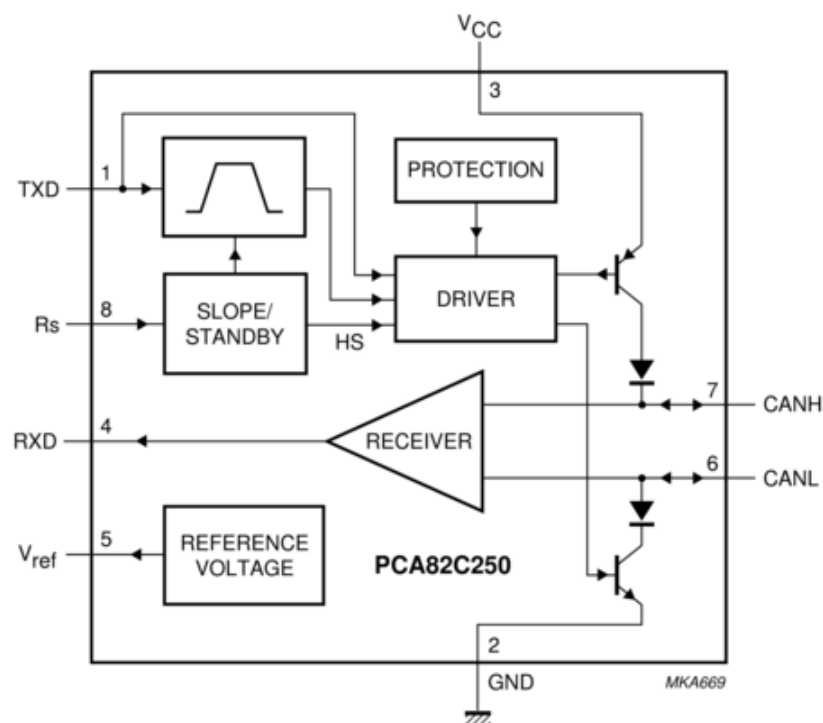

[Back to top](#)**Design support**[Hide](#)**Application Notes**

AN10211_2;TJA1040 high speed CAN transceiver (2006-11-10)
 AN00094_3;TJA1041/1041A high speed CAN transceiver (2006-11-08)
 AN00020_2;TJA1050 high speed CAN transceiver (2006-11-10)

Support Documents

75015742; Add value to your networks with CAN solutions that set the standard (2006-09-01)
 75015744; High-speed CAN transceivers TJA104x, JA1050 and PCA82C25x (2006-09-01)
 75016161; NXP Automotive networking solutions (2007-09-01)
 75015741; The vital link in the interconnected car (2006-09-01)
 PCA82C250_251_TJA1040_TJA1050; Upgrading Note PCA82C250/251 -> TJA1040, TJA1050 (2001-11-20)

[Back to top](#)**Parametrics/similar products**[Hide](#)

Type number	Package	Supply voltage (V)	Application	Configuration	CATEGORY	FEATURES	FUNCTION	Operating temp. (Cel)	No. of Pins	Package Material	Controller Type
PCA82C250T/N4	SOT96	4.75 ~ 5.25	Control Devices	HS-CAN transceiver	transceiver	ISO11898-2 compliant, standby mode	Controllers	-40 ~ +125	8	DIL8, SO8, bare die	CAN Interface
PCA82C250T/YM	SOT96	4.75 ~ 5.25	Control Devices	HS-CAN transceiver	transceiver	ISO11898-2 compliant, standby mode	Controllers	-40 ~ +125	8	SO8	CAN Interface

Similar products

PCA82C250 links to the similar products page containing an overview of products that are similar in function or related to the type number(s) as listed on this page. The similar products page includes products from the same catalog tree(s), relevant selection guides and products from the same functional category.

[Back to top](#)**Print/email**[Hide](#)

[Email this product information](#)
[Print this product information](#)

[Back to top](#)**Disclaimers**[Hide](#)

[General product disclaimer](#)
[Quality and reliability disclaimer](#)

[NXP](#) | [Privacy policy](#) | [Terms of use](#) | [Sitemap](#) | [Switch to classic mode](#)

©2006-2009 NXP Semiconductors. All rights reserved.