

Prepared		<b>Product Specifications</b> <b>AN17831A</b>	Ref No.	A-1
Checked			Total Page	9
Approved			Page No.	1

Structure	Silicon Monolithic Bipolar IC
Appearance	SIL-12 Pins Plastic Package (FP-12S Power Type With Fin)
Application	Audio
Function	44W (6Ω) x 2ch BTL Power Amplifier Built-in Standby and Muting Features Incorporating Various Protection Circuits

A Absolute Maximum Ratings					
No.	Item	Symbol	Ratings	Unit	Note
1	Storage Temperature	Tstg	-55 ~ +150	°C	
2	Operating Ambient Temperature	Topr	-25 ~ +75	°C	
3	Operating Ambient Pressure	Popr	1.013x10 <sup>5</sup> ± 0.01x10 <sup>5</sup>	Pa	
4	Operating Constant Acceleration	Gopr	9,810	m/s <sup>2</sup>	
5	Operating Shock	Sopr	4,900	m/s <sup>2</sup>	
6	Power Supply Voltage	Vcc	27	V	1
7	Power Supply Current	Icc	8.0	A	
8	Power Dissipation	Pd	37.5	W	2

Operating Supply Voltage Range	Vcc	8.0 V ~ 24.0 V
--------------------------------	-----	----------------

Note: 1) Without input signal, Vcc is up to 27V  
2) Ta = 75°C with infinite heatsink

Eff. Date	Eff. Date	Eff. Date	Eff. Date	
18-FEB-2002				

Prepared		<b>Product Specifications</b> <b>AN17831A</b>	Ref No.	B-1
Checked			Total Page	9
Approved			Page No.	2

No.	Item	Symbol	Test Cct.	Condition	Limit			Unit	Note
					Min	Typ	Max		
1	Quiescent Circuit Current	I <sub>cq</sub>	1	V <sub>in</sub> =0mV	-	150	300	mA	
2	Output Noise Voltage	V <sub>no</sub>	1	V <sub>in</sub> =0mV, R <sub>g</sub> =20kΩ	-	0.27	0.5	mVrms	1
3	Voltage Gain	G <sub>vc</sub>	1	V <sub>in</sub> =20mV	38	40	42	dB	
4	Total Harmonic Distortion	THD	1	V <sub>in</sub> =20mV	-	0.07	0.4	%	2
5	Maximum Output Power 1	P <sub>o1</sub>	1	THD=10%	12	15	-	W	
6	Maximum Output Power 2	P <sub>o2</sub>	1	V <sub>CC</sub> =24V, R <sub>L</sub> =6Ω, THD=10%	30	44	-	W	
7	Channel Balance	CB	1	V <sub>in</sub> =20mV	-1	0	1	dB	
8	Channel Crosstalk	CT	1	V <sub>in</sub> =20mV, R <sub>g</sub> =20kΩ	55	70	-	dB	2
9	Output Offset Voltage	V <sub>off</sub>	1	R <sub>g</sub> =20kΩ	-350	0	350	mV	
10	Ripple Rejection	RR	1	V <sub>r</sub> =1Vrms, f <sub>r</sub> =120Hz, R <sub>g</sub> =20kΩ	50	60	-	dB	1
11	Standby Current	I <sub>stb</sub>	1	V <sub>in</sub> =0mV	-	1	10	μA	
12	Muting Effects	MT	1	V <sub>in</sub> =20mV	70	80	-	dB	2

Note : 1) With a filter band 20Hz ~20kHz (12 dB/OCT) used.

2) With a filter band 400Hz ~30kHz used.

Eff. Date	Eff. Date	Eff. Date	Eff. Date	
18-FEB-2002				

Prepared		<b>Product Specifications</b> <b>AN17831A</b>	Ref No.	C-1
Checked			Total Page	9
Approved			Page No.	3

Description of Test Circuits and Test Methods

[Test Circuit 1]

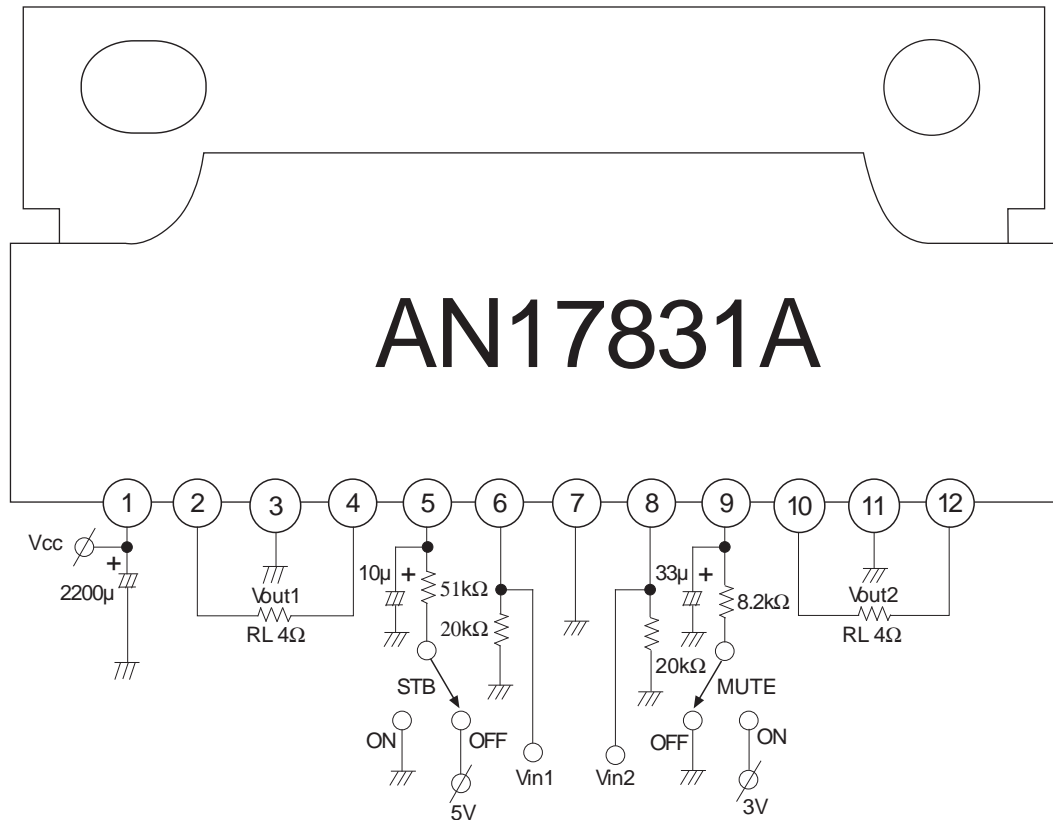

Note : \* STB 'OFF' means 5V.  
MUTE 'OFF' means 0V.

Eff. Date	Eff. Date	Eff. Date	Eff. Date	
18-FEB-2002				

Prepared		<b>Product Specifications</b> <b>AN17831A</b>	Ref No.	D-1
Checked			Total Page	9
Approved			Page No.	4

### Circuit Function Block Diagram

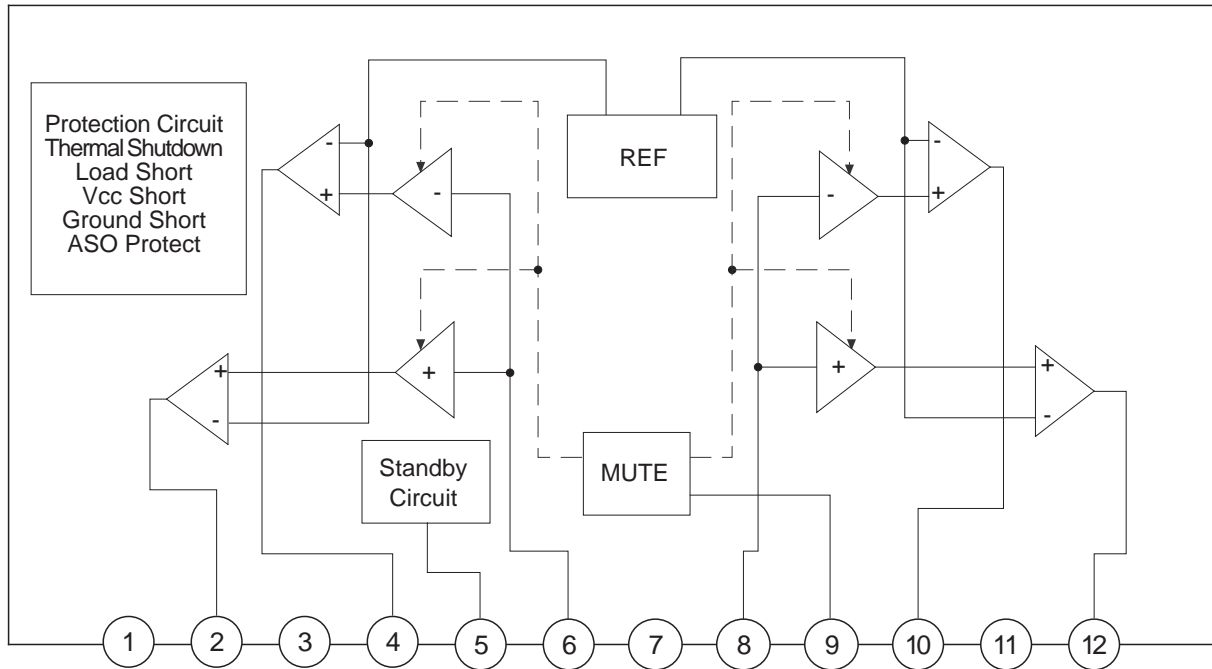

### Pin Descriptions

Pin No.	Pin Descriptions	Pin No.	Pin Descriptions
1	Vcc	7	Pre GND
2	Ch1 +ve Phase Output	8	Ch2 Input
3	Ch1 Output GND	9	Mute
4	Ch1 -ve Phase Output	10	Ch2 -ve Phase Output
5	Standby	11	Ch2 Output GND
6	Ch1 Input	12	Ch2 +ve Phase Output

Eff. Date	Eff. Date	Eff. Date	Eff. Date
18-FEB-2002			

Prepared		<b>Product Specifications</b> <b>AN17831A</b>	Ref No.	E
Checked			Total Page	9
Approved			Page No.	5

Package Name	FP-12S
--------------	--------

Unit : mm

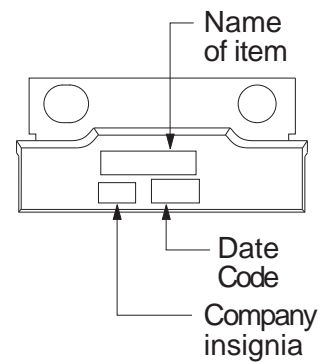
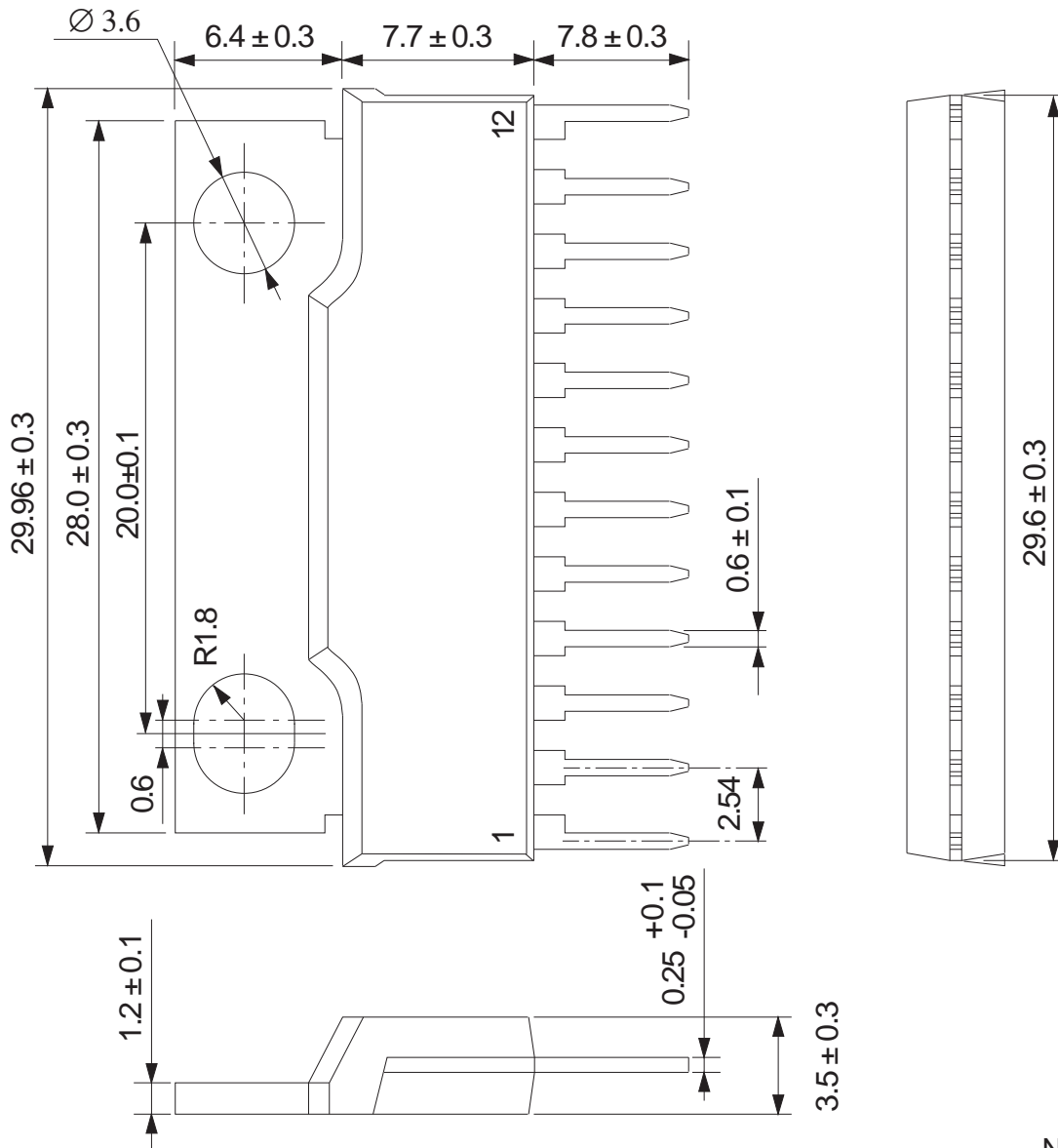

Eff. Date	Eff. Date	Eff. Date	Eff. Date
18-FEB-2002			

Prepared		<b>Product Specifications</b> <b>AN17831A</b>	Ref No.	F-1
Checked			Total Page	9
Approved			Page No.	6

(Structure Description)

Chip surface passivation	SiN, PSG, Others ( )	①
Lead frame material	Fe group, Cu group, Others ( )	②, ⑥
Inner lead surface process	Ag plating, Au plating, Others ( )	②
Outer lead surface process	Solder plating, Solder dip, Others ( )	⑥
Chip mounting method	Ag paste, Au-Si alloy, Solder, Others ( )	③
Wire bonding method	Thermalsonic bonding, Others ( )	④
Mold material	Epoxy, Others ( )	④
Molding method	Transfer mold, Multiplunger mold, Others ( )	⑤
Fin material	Cu Group, Others ( )	⑤

Package FP-12S

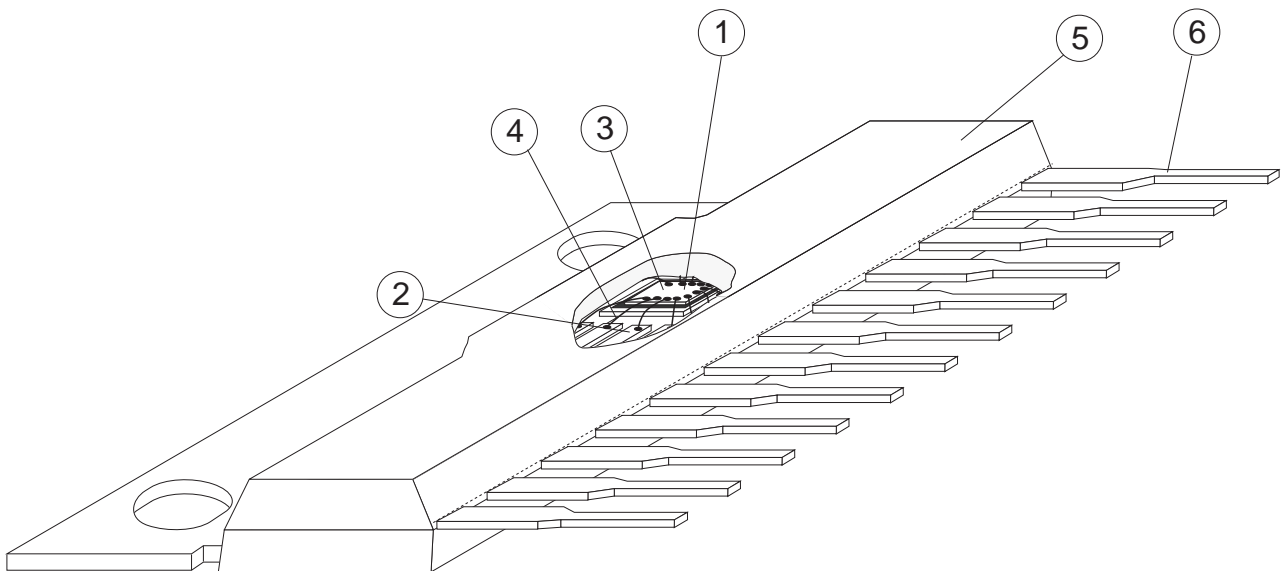

Eff. Date	Eff. Date	Eff. Date	Eff. Date
18-FEB-2002			

## Application Circuit

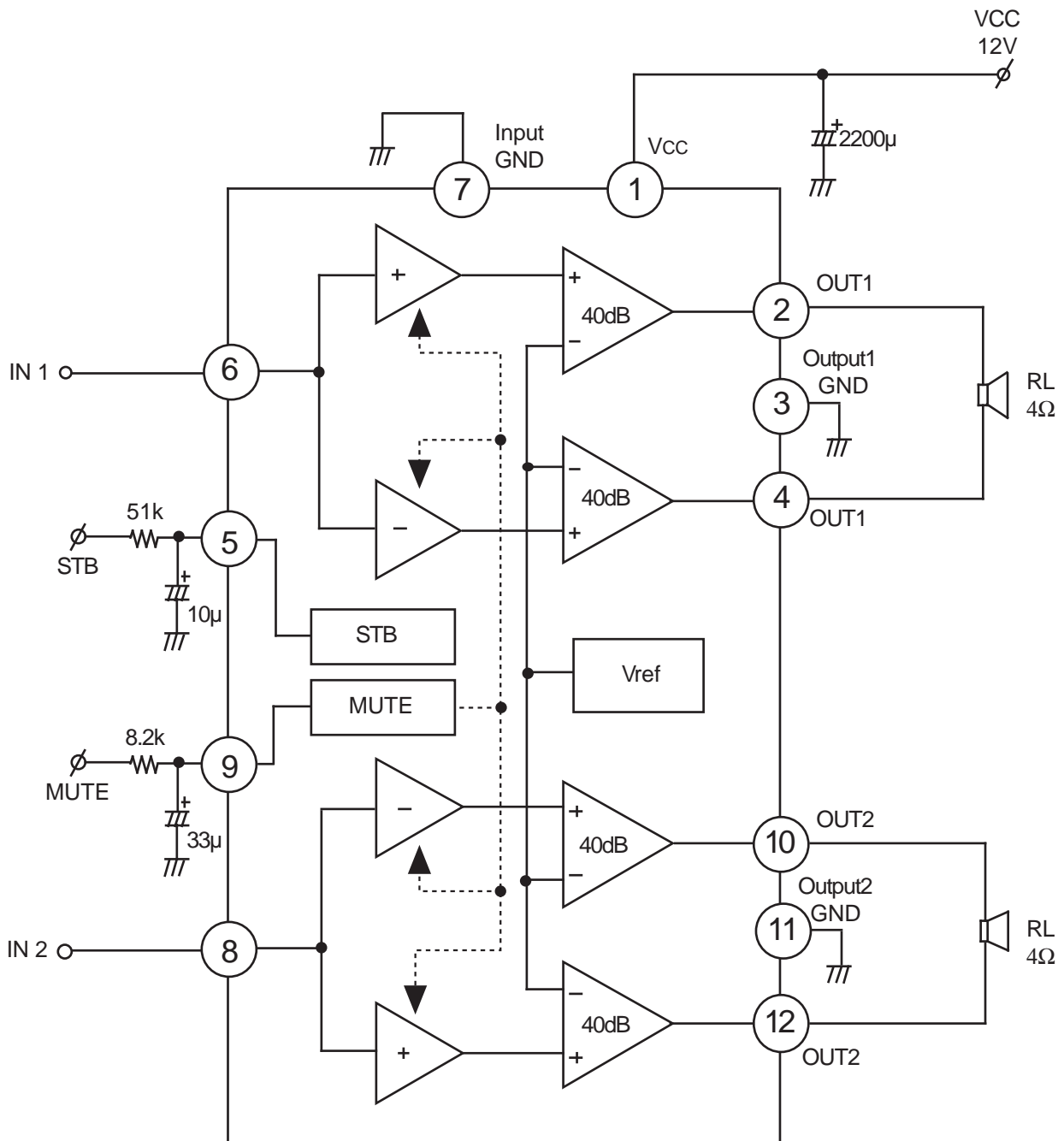

STB 'OFF'	5V
STB 'ON'	0V
Mute 'OFF'	0V
Mute 'ON'	3V

Eff. Date

Eff. Date

Eff. Date

Eff. Date

18-FEB-2002

Prepared		<b>Product Specifications</b> <b>AN17831A</b>	Ref No.	G-2
Checked			Total Page	9
Approved			Page No.	8

### PD - Ta Curves

- (1)  $T_c = T_a$ , 62.5W (  $\theta_{j-c} = 2^\circ\text{C/W}$  )
- (2) 20.83W (  $\theta_f = 4.0^\circ\text{C/W}$  )  
With a 100cm<sup>2</sup>X 3mmAl heat sink (black colour coated)  
or a 200cm<sup>2</sup>X 2mmAl heat sink (not lacquered)
- (3) 15.63W (  $\theta_f = 6.0^\circ\text{C/W}$  )  
With a 100cm<sup>2</sup>X 2mmAl heat sink (not lacquered)
- (4) 3.0W at  $T_a = 25^\circ\text{C}$  (  $\theta_{j-a} = 42^\circ\text{C/W}$  )  
Without heat sink

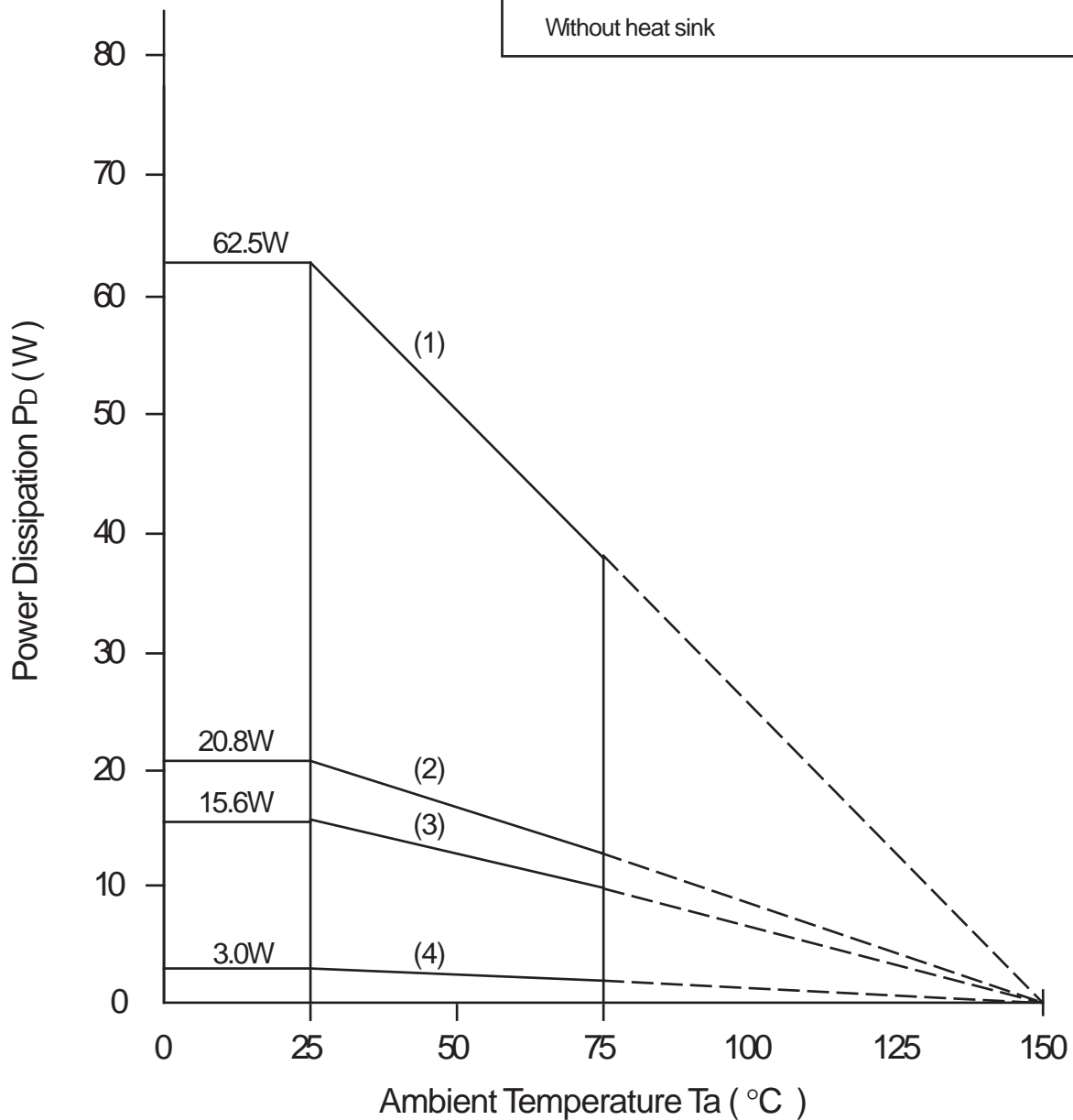

Eff. Date	Eff. Date	Eff. Date	Eff. Date	
18-FEB-2002				



Prepared		<b>Product Specifications</b> <b>AN17831A</b>	Ref No.	H-1
Checked			Total Page	9
Approved			Page No.	9

(Precautions for use)

- 1) Be sure to attach a heat sink to the IC before use. Make sure that the heat sink is secured to the chassis.
- 2) Ground the radiation fin so that there will be no difference in electric potential between the radiation fin and ground.
- 3) The thermal protection circuit operates at a Tj of approximately 150°C. The thermal protection circuit is reset automatically when the temperature drops.
- 4) The overvoltage protection circuit operates at a Vcc of approximately 28V.
- 5) Use a stabilised power supply with a 3V or higher standby voltage.

Eff. Date	Eff. Date	Eff. Date	Eff. Date	
18-FEB-2002				

Copyright © Each Manufacturing Company.

All Datasheets cannot be modified without permission.

This datasheet has been download from :

[www.AllDataSheet.com](http://www.AllDataSheet.com)

100% Free DataSheet Search Site.

Free Download.

No Register.

Fast Search System.

[www.AllDataSheet.com](http://www.AllDataSheet.com)