

Alarm Control Panel

CA-10

Program Version 4.9

Satel 
GDAŃSK

INSTALLER MANUAL





WARNINGS

Due to safety reasons, alarm system should be installed by qualified personnel only.

Telephone terminals of the panel should be connected to **PSTN lines only**. Connecting to ISDN lines may lead to damage of the equipment.

Because alarm system may contain hazardous items, its components should be kept out of reach of unqualified personnel.

In order to avoid the risk of electric shock, read carefully this manual before proceeding to installation. Any connections should be made in deenergized state only (i.e. with power supply disconnected).

In the event of service operations consisting in fuse replacement, they must only be carried out after disconnecting the supply voltage. For the replacement, use only the fuses which have identical parameters as the original ones.

It is recommended that the manufacturer's required housings and power supply units be used.

Making any construction changes or unauthorized repairs is prohibited. This applies, in particular, to modification of assemblies and components.

CAUTION !

It is impermissible to connect a fully discharged battery (voltage on terminals without a load less than 11V) to the alarm panel. To avoid hardware damage, fully discharged or never used battery should be precharged using proper charger.

The batteries used in the alarm systems contain lead. The old batteries must not be thrown away, but disposed of as required by the existing regulations (European Directives 91/157/EEC and 83/86/EEC).

Latest EC declaration of conformity and product approval certificates can be downloaded from our Web site www.satel.pl



NOTE!

The control panels with internal pulse power supply require a different approach (as compared with the previously manufactured CA-10v3.x panels) during the power-up procedure. Refer to the section on connecting power supply and starting the control panel.

CONTENTS

GENERAL DESCRIPTION OF THE CONTROL PANEL	2
TECHNICAL DESCRIPTION OF THE CONTROL PANEL	3
Zones	3
Outputs.....	5
Partitions	8
Access Codes and Authority Levels	9
Keypads	10
LED Keypad.....	10
LCD Keypad.....	10
Monitoring	11
Dialer.....	12
Remote Programming – DOWNLOADING	13
INSTALLATION OF THE CONTROL PANEL	14
Description of Control Panel Main Board	14
Connection of Keypads	17
Setting Keypad Addresses	20
Connection of Zone Expander.....	21
Connection of Detectors.....	21
Connection of Signaling Devices.....	22
Connections of Telephone Line.....	24
Connection of Voice Synthesizer	25
Connection of Printer or Computer.....	25
Connection of Power Supply	26
Description of electrical connections to the CA-10 OBU housing.....	26
Control panel power-up starting procedure	26
Starting the Control Panel	27
Hardware Access to the Service Mode	27
Programming the Control Panel from the Computer	28
ACTIVATING SELECTED FUNCTIONS.....	28
Guard Control Function	29
Telephone Messaging - Alarm Reporting.....	29
Reporting to Telephone Monitoring Station	30
Downloading - Telephone Communication with the Computer.....	32
Modem initialization	32
Programming the LCD Keypad from the Computer.....	33
REMOTE PROGRAMMING – DLOAD10	33
Program configuration for communication with the panel.....	34
DEFAULT SETTINGS.....	36
Control panel configuration (restore with FS 107 function):	36
Communication identifiers (restore identifiers with FS109 function):.....	36
Control panel access codes (restore codes with FS110 function):.....	36
TECHNICAL DATA.....	37
Control panel.....	37
LED keypads.....	37
LCD keypads.....	37

GENERAL DESCRIPTION OF THE CONTROL PANEL

The **CA-10** alarm control panel is a state-of-the-art, microprocessor-based alarm control panel, developed in accordance with the latest trends in the field of burglary and assault signaling. Its comprehensive features and affordable price permit application of the CA-10 both in small and medium-size alarm systems.

The alarm control panel incorporates a number of solutions, which were previously encountered only in special purpose equipment. Some of the solutions are an absolute novelty.

Basic functional features:

- operating the panel from remote **LCD text display** keypads or from LED keypads,
- remote control by means of a telephone set (selected functions) – **support of the MST-1 module**,
- connection of up to **four independent keypads**,
- possibility of **four-partition** operation, with completely separate alarm systems, or common zone partitions or internal partitions,
- **10 to 16 fully programmable zone inputs** (8 zones on the main board, 2 on each keypad, extension through zones of next keypads or expander), each capable of performing one of 21 functions,
- support of any detectors in NO, NC, EOL and 2EOL configuration with individual zone violation,
- **6 programmable outputs**, each being able to perform any of 41 functions.
- built-in **telephone communicator** for:
 - messaging to two monitoring stations,
 - messaging alarm condition via **pager** systems,
 - messaging alarm condition with **voice announcement**,
 - **answering a call** and reporting the system status,
 - **remote service** from a modem equipped computer,
- built-in **RS-232 interface** makes it possible to connect a printer (for printing event log or current data) and program the control panel from a PC.
- **internal clock** for automatically arming / disarming partitions with TIMER function,
- operating the system with independent access codes by **32 users** (up to 13 in each partition) - the codes can have different authority levels, and their use is recorded in the event log,
- nonvolatile **memory of 255 last events**, which gathers information about arming, disarming, alarms, troubles, etc., with date and time of occurrence, and panel user number,
- possibility to **supervise guard rounds** with TIMER function,
- automatic monitoring of the alarm system performance, inclusive of finding a **damaged or blocked detector**.

TECHNICAL DESCRIPTION OF THE CONTROL PANEL

Zones

In its basic configuration, the CA-10 control panel has 10 zones: 8 on the panel main board and 2 in the keypad. In its full configuration, with four keypads (or an expander), the panel has 16 zones available. The zones can support any detectors in the configuration NC, NO, EOL, 2EOL/NC, 2EOL/NO. The use of 2EOL configuration enables the panel to simultaneously control the detector and its anti-tampering circuit by means of one pair of wires.

The zones can perform the following functions in the system:

- 0 - entry/exit** - the violation of which, when in the armed mode, will start countdown of the entry delay time and will enable the delay mechanism for INTERIOR DELAY type zones (violation of an INTERIOR DELAY zone without prior violation of the ENTRY/EXIT zone will trigger an alarm immediately). Upon violation, a "zone violation" code is sent to the report station (it is possible to skip sending this message), and, after counting down the "entry delay time" and triggering the alarm - a "zone alarm" code. The "entry delay" countdown can be signaled in the keypad. It is possible to define automatically bypassing zones if no ENTRY/EXIT zone is violated during the exit delay time". Because of its additional functions, this zone type cannot be used as a common zone for several partitions.
- 1 - delay** - when violated in the armed mode, it starts delay countdown, after which an alarm is triggered. It will not occur if the zone is disarmed before completion of the delay countdown. Upon violation, a "zone violation" code is sent to the report station (it is possible to skip sending this message), and, after counting down the "entry delay time" and triggering the alarm - a "zone alarm" code. The delay is not signaled in the keypads.
- 2 - interior delay** - when violated in the armed mode after previous violation of the ENTRY/EXIT zone, it behaves like a DELAY zone. When violated in the armed mode without previous violation of the ENTRY/EXIT zone, it behaves like an INSTANT zone.
- 3 - instant** - when violated in the armed mode, it immediately triggers an alarm and sends a "zone alarm" message to the monitoring station.
- 4 - day/night** - when violated in the armed mode, it behaves like an INSTANT zone, while when disarmed, it will signal violation in the keypad (unless the signaling is disabled) and send a "zone violation" code to the station.
- 5 - counting L1** - when violated in the armed mode, it increases the status of the first of three violation counters (a „zone violation" code is sent to the station), until the number of violations specified for that counter is exceeded (programming in FS7). Then, the violation triggers an alarm (a „zone alarm" code is sent to the report station). The violation counter is reset after 30 seconds since the first violation. It is possible to program another counter count-up time (FS123). If the preset number of violations is not reached within this time, there will be no alarm. More than one zone can be define as COUNTING L1. Violations of those zones will be summed up. Violation of the counting zone in armed mode can be signaled in the keypad in the same way as for the DAY/NIGHT zone.
- 6 - counting L2** - operation identical as for the "counting L1", but changes the status of the second of the three counters.
- 7 - counting L3** - operation identical as for the "counting L1", but changes the status of the third of the three counters.

- 8 - 24H audible** - armed all the time, irrespective of whether the partition it is assigned to is armed, or not. Each violation of this zone will trigger alarm on the BURGLARY ALARM type outputs, in the keypad, and will send a "zone alarm" code. It makes possible to create anti-tampering circuits and panic buttons.
- 9 - 24H auxiliary** - armed all the time, irrespective of whether the partition it is assigned to is armed, or not. Each violation of this zone will trigger an alarm in the keypad and will send a "zone alarm" code. It is intended for connecting detectors not related to the burglary alarm, such as gas or flooding sensors, etc.
- 10 - 24H silent** - armed all the time, irrespective of whether the partition it is assigned to is armed, or not. Violation of this zone will only send a "zone alarm" code to the monitoring station.
- 11 - 24H fire** - armed all the time, irrespective of whether the partition it is assigned to is armed, or not; intended to manage the fire detectors.
- If the control panel contains an output programmed as the FIRE DETECTORS POWER SUPPLY, violation of the zone will actuate the alarm verification mechanism and will signal alarm in the keypad. To perform the verification, disconnect momentarily power supply to the fire detectors and check, whether after reconnection of power supply the violation will be repeated within 90 seconds. If that's the case, the control panel will send a „zone alarm" message to the monitoring station, activate the FIRE ALARM and FIRE/BURGLARY ALARM outputs, and trigger the fire alarm (intermittent signal) in the keypad.
- If there are no FIRE DETECTORS POWER SUPPLY outputs, the zone violation will immediately send a „zone alarm" code to the monitoring station, activate the FIRE ALARM and FIRE/BURGLARY ALARM type outputs, as well as trigger the fire alarm (intermittent signal) in the keypad.
- 12 - arming** - violation of this zone will arm the partitions the zone belongs to.
- 13 - silent arming** - violation of this zone will arm in silent mode the partitions the zone belongs to.
- 14 - disarming** - violation of this zone will disarm the partitions the zone belongs to.
- 15 - no alarm action** - violation of this zone will activate the ZONE VIOLATION type outputs.
- 16 - arming/disarming** – controls arming/disarming of partition to which this zone is assigned. Setting of "PRIORITY" option allows to choose one of two different modes:
PRIORITY option enabled: zone violation will arm the partition, while end of violation will disarm the partition ("Bistable" action).
PRIORITY option disabled: each violation of the zone will trigger partition's state between "Armed" and "Disarmed" state ("Monostable" action).
- 17 - delay audible** – a delayed zone with the delay countdown signaling in keypads.
- 18 - automatic bypass arming** – violation of this zone arms the partition the zone belongs to, simultaneously bypassing the zones programmed as AUTO-BYPASS (see FS16 – FS19).
- 19 - perimeter** – zone armed since entering the access code and confirming it with the [#] key (i.e. arming the partition). Violation of this zone during countdown of the „exit delay" will trigger an alarm.
- 20 - entry/exit-final** – acts much like the type 0 (ENTRY/EXIT) zone, but the violated zone restore during exit delay countdown will stop the countdown and begin the partition armed mode.

Reaction time for each zone can be programmed within 0.016 s to 4.08 s.

For each of the delayed zones, an individual time delay can be set.

Each zone involves a few options to determine the reaction in particular situations.

It is possible to determine for each zone the maximum violation time (in seconds), after which the zone will be recognized by the control panel as defective, and to determine the maximum "no violation" time (in hours), after which the zone will be recognized by the control panel as defective.

The zones can be selectively bypassed.

For each zone can be determined the 9 event codes to be sent to the monitoring stations.

Outputs

The CA-10 is equipped with 6 programmable outputs: 4 high-current and 2 low-current ones.

The OUT1, OUT2, OUT3 and OUT4 outputs are protected by special electronic fuses with current limiters set at 2.2A. The panel monitors presence of voltage, overload, and signals trouble conditions at these outputs. 2.2k Ω resistors must be connected in parallel to these outputs. The above outputs supply the load with +12V voltage.

The OUT5, OUT6 outputs (low-current, up to 50mA) control ground of the load.

All outputs are equipped with protective devices for inductive loads and pulse interference.

For each output can be defined the operation time in seconds (from 1 to 99 seconds), in minutes (from 1 to 99 minutes), or LATCH type (until cut off). It is possible to determine the output polarity for active state (+12V or 0V on the load), and whether it should operate in pulsed or continuous mode.

Assignment of the particular outputs can be restricted to the specific partitions / zones of the system.

Designation of the outputs can be adapted for the needs of the alarm system controlled by the panel. Though individual outputs differ by their design, each of them can perform one of the following functions:

- 1 - burglary alarm** - the output starts on detecting a burglary alarm by the control panel. The alarm is triggered by armed zones, zone anti-tampering circuits, keypad tamper detectors, and by the user (through the ALARM PANIC function). If the zones to which the output is to react are defined, the zone alarms will be limited to those included in the „list of outputs” (the other alarms will be effected irrespective of the source). It is also possible to indicate (in the output options) the partition the output is associated with. If this is the case, the zone alarms will be limited to those from the zones belonging to the partition indicated. When the "list of outputs" is empty and no partitions are indicated, the output reacts to all alarms (except for the fire alarms).
The output can remain active for a specified time (from 01 to 99 seconds or from 01 to 99 minutes) or until the alarm is cleared by the user. During its operation, it can every second change its state (pulsate).
- 2 - fire/burglary alarm** - the output starts on detecting by the control panel of a burglary alarm (continuous signal) and/or a fire alarm (intermittent signal). The output operation can be limited to the indicated "list of outputs" or a specific partition (identically as for the **1** output type). The output can remain active for a specified time (from 01 to 99 seconds or from 01 to 99 minutes) or until the alarm is cleared by the user.
- 3 - fire alarm** - the output starts when the control panel detects a fire alarm. Such an alarm is triggered by fire zones or the user (through the FIRE ALARM function). The output operation can be limited to the specified "list of outputs" or particular partitions (identically as for the **1** output type), indication of any zones other than the fire ones having no sense, as they would not generate a fire alarm. The output can remain active for a specified time (from 01 to 99 seconds or from 01 to 99 minutes) or until

the alarm is cleared by the user. During operation, it can every second change its state (pulsate).

- 4 - **keypad alarm** - the output starts on detecting any keypad alarm (FIRE, PANIC, AUX., keypad tamper alarms). The output operation can be limited to the alarms from specified partitions. The output can remain active for a specified time (from 01 to 99 seconds or from 01 to 99 minutes) or until the alarm is cleared by the user. During its operation, it can every second change its state (pulsate).
- 5 - **keypad fire alarm** - the output starts on triggering the fire alarm by the user (with the FIRE ALARM function). The output operation can be limited to the alarms from specified partitions. The output can remain active for a specified time (from 01 to 99 seconds or from 01 to 99 minutes) or until the alarm is cleared by the user. During operation, it can every second change its state (pulsate).
- 6 - **keypad panic alarm** - the output starts on triggering the PANIC alarm by the user. The output operation can be limited to the alarms from specified partitions. The output can remain active for a specified time (from 01 to 99 seconds or from 01 to 99 minutes) or until the alarm is cleared by the user. During operation, it can every second change its state (pulsate).
- 7 - **keypad aux. alarm** - the output starts on triggering the alarm by the user with the ALARM AUX function. The output operation can be limited to the alarms from specified partitions. The output can remain active for a specified time (from 01 to 99 seconds or from 01 to 99 minutes) or until the alarm is cleared by the user. During operation, it can every second change its state (pulsate).
- 8 - **keypad tamper alarm** - the output starts on detecting violation of the tamper contact or a change of the keypad address, and also after 3 wrong codes. The output operation can be limited to the alarms from specified partitions. The output can remain active for a specified time (from 01 to 99 seconds or from 01 to 99 minutes) or until the alarm is cleared by the user. During operation, it can every second change its state (pulsate).
- 9 - **day/night + counting** - the output starts on detecting violation of disarmed DAY/NIGHT zone or violations of COUNTING zones, which trigger no alarm. Operation of the output can be restricted to a specified "list of outputs" or particular partitions (identically as for the 1 output type). Indication of any other zones than those tested by this output type is irrelevant - they will give no violation signal. The output can remain active for a specified time (from 01 to 99 seconds or from 01 to 99 minutes) or until the alarm is cleared by the user. During operation, it can every second change its state (pulsate).
- 10 - **duress alarm** - the output starts on using an access code with authority level 4 (DURESS) to disarm the system or to signal an alarm. This code is used to trigger a special "disarm under duress" alarm. Operation of the output can be restricted to alarms from particular partitions. The output can remain active for a specified time (from 01 to 99 seconds or from 01 to 99 minutes) or until the alarm is cleared by the user. During operation, it can every second change its state (pulsate).
- 11 - **chime** - the output starts on violating the disarmed zones for which the "chime" option has been activated. Operation of the output can be restricted to the indicated "list of zones" or to specified partitions (identically as for the 1 output type). The output can remain active for a specified time (from 01 to 99 seconds or from 01 to 99 minutes) or until the alarm is cleared by the user. The output signals violations irrespective of the chime lock setting in keypad (the lock is called by holding down the [8] key).
- 12 - **switch MONO** - the output is activated by calling the user function 7 ([CODE][*][7]) or using a code with authority level 5 ([CODE][#]). Operation of the output can be

restricted to specified partitions. The output can remain active for a time from 01 to 99 seconds or from 01 to 99 minutes.

- 13 - **switch BI (ON/OFF)** - the output changes its state when the user function 8 is called or a code with authority level 6 is used. Operation of the output can be restricted to specified partitions.
- 14 - **arm status** - the output is active when the system is armed. Operation of the output can be restricted by indicating a „list of zones” or specific partitions. Unless zones and partitions are indicated, the output is active when any partition (zone) is armed.
- 15 - **silent arm status** - the output is active when the system is in the silent armed mode. Operation of the output can be restricted by indicating a „list of zones” or specific partitions.
- 16 - **exit delay status** - the output is active during the „exit delay” countdown by the control panel. Operation of the output can be limited to indicating the „exit delay” for specified partitions.
- 17 - **entry delay status** - the output is active during the „entry delay” countdown. Operation of the output can be limited to indicating the „entry delay” for specified partitions.
- 18 - **telephone usage status** - the output is active when the control panel is on the telephone line.
- 19 - **ground start** - the output is activated by the control panel to generate the GROUND START pulse (a 2 sec. signal occurring before the control panel "lifts the handset", required by a specific type of telephone exchanges).
- 20 - **report acknowledge** - the output activated for 3 seconds by the control panel, after correct termination of the monitoring session.
- 21 - **bypass status** - the output is active when some zones are bypassed in the system. Operation of the output can be limited to showing the bypass of zones specified in the list of zones, or the bypass of indicated partition zones.
- 22 - **ready status** - the output is active when all the control panel zones are free from violations. Operation of the output can be limited to showing the READY status of zones specified in the list of zones, or the READY status of indicated zones.
- 23 - **zone violation status** - the output starts when one of the zones is violated. Operation of the output can be limited to the indicated "list of zones" or specified partitions (identically as for the 1 output type). The output can remain active for a specified time (from 01 to 99 seconds or from 01 to 99 minutes) or until the armed mode is deactivated or the alarm cleared.
- 24 - **telephone line trouble** - the output used when telephone messaging is doubled by radio messaging; it makes possible reporting the telephone line trouble.
- 25 - **230V AC loss indicator**
- 26 - **battery trouble indicator** – activated when the battery voltage in three consecutive tests drops to about 11V.
- 27 - **power supply** - the output intended for powering detectors, encoders, radio lines and other equipment with 12V direct voltage. When programming this type of output, pay special attention to permissible current-carrying capacity of each of the control panel outputs.
- 28 - **fire detectors power supply** - the output intended for powering the fire detectors. The output closely interacts with the 24H FIRE zones. If assigned to any of the control panel outputs, the function activates the fire alarm verification mechanism. The mechanism operates as follows: the first violation cuts the fire detectors power supply off for about 15 seconds. The power-down results in reset of the violated detectors. Then, the power supply is restored, but the panel will not control the 24H FIRE zones for 10-20 seconds because of the balancing of detectors. Next, the control panel

enters the special mode of fire detectors control, which lasts about 90 seconds. If a repeated detector violation occurs during that time, a FIRE alarm will be triggered. Otherwise, the control panel will go over to the normal control of 24H FIRE zones. The output reacts to the "RESET POWER SUPPLY" function (user function 9, cutoff for time programmed as the output active time).

- 29 - power supply with RESET function** - the output is designated to power detectors which require a periodical power cut-off until the state memory is cleared. The RESET mechanism is activated from keypad through the user function 9 (calling: [CODE][*][9]). The voltage is cut off for time programmed as the output active time (minimum 5 seconds).
- 30 - timer** - the output is controlled by the control panel clock; it is activated / deactivated in the hours indicated by a corresponding TIMER.
- 31 - audible arm status** - the output signals the audible armed mode. Operation of the output can be limited to the indicated "list of zones" or specific partitions.
- 32 - full arm status** - the output is only active when all zones / partitions assigned to it are in the armed mode.
- 33 - arm/disarm/clear alarm** - the output signals the performance of particular operations with, respectively, one, two, or four pulses 0.16s each.
- 34 - keypad buzzer alarm** - silent alarm signaling in the partition keypad.
- 35 - power supply on armed mode** - it functions similarly to the arm status output, but goes on right after starting the exit delay countdown, not after changeover from the exit delay to the armed mode (it can be used, for example, as indicator or power supply output for microwave detectors in spaces where people stay).
- 36 - LED status** – the output can control a LED to indicate the following statuses:
- off – control panel disarmed
 - steady light – control panel armed
 - blinking light – the control panel armed, there was alarm or trouble
- Note:** *If in the armed mode any zones are violated in the system, the LED will be blinking and will only change to steady light after the violation ends.*
- 37- RELAY status** – the output can control a relay. The output becomes active after arming, and inactive after an alarm is triggered, a trouble occurs, or the system is disarmed.
- Note:** *If in the armed mode any zones are violated in the system, the output will become active after the violation ends.*
- 38 - zone trouble** – the output signals that the maximum zone violation time or the maximum zone no violation time have been exceeded.
- 39 - no guard code** – the output is activated by a timer programmed as the partition control TIMER, unless a guard code is entered within the timer specified time.
- 40 - service mode status** – the output is activated if the control panel service mode has been called from any keypad.
- 41 - battery test result** - the output whose state is updated after each battery voltage test.

Partitions

Creation of a partition consists in assigning at least 1 zone to it. The CA-10 permits 4 partitions to be created. Any outputs, telephone numbers and pager messages can be assigned to one partition, thus enabling four independent alarm systems to be built on the basis of one CA-10 control panel.

In the event of a few keypads being connected to the control panel, each keypad will be hooked up to the particular partition via a special control output. The keypad connected to the CLK1 output will belong to the partition 1, that connected to the CLK2 output - to the partition 2, etc.

Where the system comprises less keypads than partitions, individual partitions can be operated from the existing keypads, by means of the GO TO function (when this function is called, the keypad will for a time belong to another partition). The partition which has no keypad, can be controlled through the zones to which the "arming" and "disarming" functions are assigned. The state of such a partition can be signaled on the outputs.

Partitions can be defined in the following way:

- partitions have no common zones - they are independent sub-systems,
- some zones belong to several partitions - the common zones are only armed when all the partitions these zones belong to are armed,
- all zones of one partition belong at the same time to another partition - the control panel recognizes one partition as the master, and the other as an internal one; arming/disarming the master partition results in simultaneously arming/disarming the internal partition, while arming/disarming the internal partition only affects the zones within that partition,
- the same zones are assigned to different partitions - these partitions will become mutually internal; arming/disarming one partition causes identical reactions in the other partition: thus defined partitions behave like one partition with two (or more) independent keypads.

When analyzing, if the given partition is an internal one, the control panel checks how the zones for which arming is possible overlap. Therefore, an internal partition can be assigned with separate "24H" zones as well as arming control zones.

The partitions have individual identifiers and event codes for monitoring purposes.

Access Codes and Authority Levels

The CA-10 panel can store in memory 32 access codes (4 to 6 digits long), with different authority levels. The codes are associated with the partitions they are assigned to. The each partition has a MASTER code. The MASTER code cannot be deleted, however it can be changed. It provides access to all user functions.

The MASTER code user (user number 0) can add new users to partition, assigning various authority levels to them. The code authority level defines which functions of the control panel are accessible by using this code, and which are not.

New users (new codes) are automatically numbered by the control panel as they are entered. This makes it possible to distinguish, who and when operated the control panel, as the user (code) number is stored in the memory of events along with the command given. With the LCD keypad, identification of the users by their name is also possible.

Deletion of the code will not cause renumbering of the other users' access codes. Whenever a new user is added, his code will replace the one left by the deleted user.

Access codes can be declared as the „global access codes” (FS131). Then they will be accepted in each partition, irrespective of in which partition they are entered. However, with this option it is impossible to identify the user who called the control function when viewing the event log.

Note: *Creating inner partitions in the system, with the option of global access codes on, enables the basic partition to be controlled with the master codes of these partitions. If these codes are not used, they should be changed for the safety reasons.*

Individual users may have the following authority levels:

1 - accessible **all functions**, except creating and deleting users,

- 2 - accessible **arming and disarming, change of access code,**
- 3 - accessible **arming**, while **disarming is only possible when the system was armed with the same access code,**
- 4 - **code trap**: it arms and disarms the system, but disarming sends a DURESS ("disarmed under duress") message to the monitoring station,
- 5 - activates the MONO SWITCH output, **its use is recorded in the event log**, can serve as a guard code,
- 6 - changes the state of BI SWITCH output,
- 7 - **partial arming** - the code arms the system, simultaneously bypassing a group of zones (specified by the installer in service functions), otherwise the code provides the same features as that with authority level 2,
- 8 - accessible **arming and disarming, without possibility to change own access code,**
- 9 - accessible **arming only,**
- 0 - accessible **alarm clearing only.**

Keypads

The keypads are designed for operating and programming the system (or a partition). The CA-10 can support four independent LCD or LED keypads, thus making possible creation of four partitions or separate systems. **Each keypad is assigned to one partition.**

The keypad operating mode is set when programming the panel. It is possible to disable some of its functions (e.g. the quick arming by pressing in turn the [0] and [#] keys), and determine what audible signals are to be provided by the keypad.

The keypads have an individual addresses, which make difficult replacement or connection of another keypad, an individual anti-tampering contact and two zones, which operate identically as the zones of the control panel main board. The keypad zones can be assigned to any partition.

The data concerning the address, anti-tampering contact status and zone status, are sent to the control panel together with keypad data.

LED Keypad

There are three types of LED keypads available to interface with the CA-10 panel, which have the following designations: CA-10 KLED, CA-10 KLED-M and CA-10 KLED-S.

In LED keypads the status of partitions and zones is indicated by means of LEDs (the CA-10 KLED keypad can display the status of up to 12 zones). Additionally, three LEDs provide information on the system status: the red LED indicates ALARM, the green one - ARMED (blinking means countdown of the exit delay), and the yellow one - TROUBLE.

For details regarding the keypad indication see the *CA-10 User Manual*.

LCD Keypad

There are three types of LCD keypads available (to interface with the CA-10 panel), which have the following designations: CA-10 KLCD, CA-10 KLCD-L and CA-10 KLCD-S. The CA-10 panel supports the keypads with program version v2.00 (or later).

The LCD keypad provides information on the alarm system status by means of a two-line (2 x 16 characters) LCD display and, additionally, six LEDs. The LED functions are described in the „ *CA-10 User Manual*”.

The keypad is provided with 12 keys, designated according to the telephone standard, and intended for entering data. The additional 4 arrow keys in the LCD keypad allow the user to move through the MENU and to select functions.

Three operating modes of the keypad are provided:

1. **Text mode.** The first line of the display shows the system date and time. The second line contains messages on the system state. The contents of messages can be either standard (e.g. *SYSTEM OK.*, *ARMED*), or customized by the installer. This mode enables the status to be displayed either with or without priority. In the priority mode, the most important information message from among a few relevant ones (e.g. *ALARM !*) will be constantly on. In the non-priority mode, the display state will change cyclically (e.g. the messages *THERE WAS ALARM* and *ARMED* will be displayed alternately).
2. **Zone state display - LCD standard.** The first line of the display shows the system date and time, while the second serves for monitoring the state of all the 16 zones of the control panel. The zone state is determined by a displayed character (for example: ■ = zone OK., ● = zone violated). At the moment of changing the system state (e.g. when the system is armed), the display shows the status for a while, much in the same way as in the previous mode, then the keypad returns to monitoring the state of zones.
3. **Zone state display - LED standard.** This mode is similar to the mode 2. The difference is that in the second line the state of 12 zones of the control panel is being monitored in the same way as it is the case in the LED keypad.

The operating mode 1 or 2 is recommended for the LCD keypad. Having selected the mode 1, the user can temporarily switch the display between the text mode and the zone state mode by holding down the ▼ key.

The operating mode is defined by the installer with the *Status format* service function (→Service Mode; →LCD Keypad; →Settings; → **Status format**), available only after activation of the control panel service mode.

The LCD keypad is fitted with a RS-232 port to enable programming the keypad settings directly from the computer (see section: *Activating selected functions*).

Monitoring

The CA-10 control panel can transmit information about the system (partition) status to one or two monitoring stations. Communication with the monitoring stations takes place irrespective of the voice messaging and the messaging to paging systems. It has a priority and is realized before the voice messaging. In case problems occur with getting connected to the station, the control panel will suspend dialing the station number for 60 seconds and, if the message is also to be transmitted by the dialer, it will make the line available to the dialer.

There are a few ways of transmitting information to the monitoring stations.

- **Reporting to one station.**
- **Reporting to Station 1, and if unavailable - to Station 2** (e.g., when the station has two telephone numbers). If this is the case, all events are reported, irrespective of which station was reached by the control panel.
- **Reporting to both stations with event sorting** - depending on what event occurred in the system, e.g. information on alarms to Station 1, and information on troubles to Station 2 (this mode is useful where the station serves many subscribers and it is necessary that the number likely to receive most vital information be busy as little as possible). In this mode, during control panel programming, you can determine which information is to be sent to which station.
- **Reporting to both stations:** Station 1 first, then Station 2. This mode is reached by assigning the same event to both stations.

In case of a system with 16 zones and 32 users, the number of messages to be sent to the monitoring station in order to ensure an appropriate facility protection degree may be large enough to exceed the capacity of standard transmission formats. Therefore, to increase the control panel flexibility, the events occurring in the system have been divided into six groups:

- the first one includes the **zone related events** (this group has the highest priority),
- four groups are represented by the **partition related events** (the event priority depends on the partition number, the first partition having the highest priority),
- the sixth group accounts for the other **system events**.

Individual system identifiers are assigned to each group of events (one for each station). In the event of stations which cannot accept several different identifiers in one communication session, the control panel can send the events in separate sessions, in the order resulting from the priority, grouping events with the same identifiers.

It is possible to send information on nine different zone related events and seventeen partition related events (whereof seven events may contain the user number). The control panel is also capable of sending twenty six other events which occurred in the system (e.g. troubles, start of programming mode via a telephone, activation of service mode, etc.). The event codes for both stations are the same. For a majority of events, it is possible to define how the events are to be sorted between the two stations. Information can be sent to the stations in one of the seventeen transmission formats (including the TELIM format, used in Germany).

Because of the analysis of commutation signals (algorithm ToneLOGIC), the CA-10 panel controls the process of establishing connection with the station, which in case of the line being frequently busy considerably reduces the time between occurrence of the event and sending information to the monitoring station. As dialing retries are made immediately after detecting the busy signal, the connection is established many times faster than with the equipment which waits for one specific signal for a predetermined period of time and only redials upon detecting that that signal has not occurred.

Dialer

The CA-10 control panel is equipped with a telephone dialer, which enables an alarm voice message to be transmitted. The message is stored in an external synthesizer. The control panel directly interfaces with the SM-2 voice synthesizer.

The dialer can also establish connections with paging systems. Four different alphanumeric messages can be programmed.

The CA-10 allows programming of eight telephone numbers, 16 characters each.

It is possible to define for each number, which partitions signal alarm at that number and assign to it one of the four text messages for the pager or a voice announcement from the synthesizer.

During the procedure of connection setup, the ToneLOGIC system used in the CA-10 panel controls sound signals from the telephone line. Hence, it can recognize that the call is answered, irrespective of the type of telephone exchange.

Messaging for each telephone number is realized in accordance with the following parameters:

- **number of queues** (1 to 7) – defines how many times it is necessary to call and send information to each number,
- **maximum number of retries** (1-9) – number of attempts, after which the panel will stop dialing the number, for which connection cannot be established (no answer, permanently busy, etc.).

When waiting for the dial tone during dialing (code D, when the control panel is connected to an extension line and is trying to get the outside line), detecting the busy signal does not decrease the counter of queues and attempts.

The control panel dialer can also perform the function of answering the calls and reporting the system state (service functions FS5 and FS101):

- with a sound signal: one beep a second if there was no alarm,
- with a voice message (if one hour has not elapsed yet after the alarm),
- with a sound signal: five short beeps every second if at least one hour has elapsed from the alarm.

Another way of getting information on the system state via the telephone is through the control panel operation in conjunction with the SATEL **MST-1** module (service function FS131). Additionally, this module enables the system to be remotely controlled, within certain limits, by means of DTMF signals. For the connection diagram refer to the MST-1 module operating instructions.

Remote Programming – DOWNLOADING

In order to facilitate programming, the CA-10 panel is equipped with a DOWNLOADING mechanism, which enables a PC computer to be used for programming and service control of the alarm system.

Operation with the computer can be realized in two ways: in the „*local mode*” by means of the RS-232 interface (after connecting the CA-10 directly to one of the computer COM ports), or in the „*remote mode*”, via the telephone line (in this case the computer must be equipped with a modem).

Programming the data of LCD keypad is available in the local mode through the RS-232 port on the keypad board.

The DLOAD10 program, delivered with the panel, supports both operating modes.

The DLOAD10 program enables:

- downloading (reading) all control panel parameters,
- uploading (writing) new parameters to the control panel,
- downloading (reading) the system event log.

The program does not read or change the user access codes - these are only accessible through the user functions from keypads.

In the **ONLINE** mode, the computer displays current information on the system state, including zone violations, active outputs, control panel clock, and selected partition state. Provision is made for controlling the system in the same way as with a LED keypad. The computer screen keypad works in parallel with the real keypads in partitions, therefore commands for all partitions can be given from one place. The ONLINE mode also permits downloading troubles and programming the clock.

Communication in the local mode (through the RS-232 port) is started with a special service function (FS112). Connection can also be initialized without using the keypad (e.g. if it is located far from the control panel and the computer). This can be achieved using the "Local connection with..." command in the DLOAD10 program.

Communication through the telephone line can be initialized in three modes:

1. The computer calls the control panel, which after answering the call exchanges handshake signals with the computer. When they are correct, the panel confirms acceptance of the remote programming command, hangs up and calls back to the computer using a number preprogrammed in the control panel. Prior to calling the computer back, the panel notifies the monitoring station that the programming has started.
2. The computer calls the control panel and, after the handshake, the control panel immediately proceeds to the exchange of data. This simplified mode of establishing communication is reached when the computer telephone number is not entered in the control panel. Notification of the monitoring station will take place after communication with the computer is over.

3. Establishing of communication from the control panel by calling the user function 0 (zero). The control panel first notifies the monitoring station that the programming has started (when monitoring is active), then it dials the computer telephone number.

In order to reduce the cost of telephone connections, multiple suspension of the transmission is possible. At the next connection, the control panel does not inform the monitoring station of remote programming. Only after receiving the command to end the communication, a message on completing the remote programming is sent to the station.

Initialization of communication can be disabled from the computer. When the communication is suspended from the computer, the control panel is waiting for a call from the computer for four hours even when the functions of automatically answering the computer call are disabled. When the communication is ended with the "end" command instead of "suspend", the information on ending the communication is entered into the event log and sent to the monitoring station after four hours.

As the control panel is only accessible to the service, a number of protective devices is provided to prevent hacking of the system and change of any data by unauthorized persons. All the data exchanges are authorized by changing the access codes and the data are encoded.

The DOWNLOADING can be particularly useful to installation firms engaged in servicing many alarm systems. Then the user suggested inspections and modifications of software will not necessarily require troublesome and costly traveling - they will be carried out with a computer via the telephone line. Such a method of customer service and technical control of customer systems will allow creation of alarm equipment services at an advanced and professional level.

INSTALLATION OF THE CONTROL PANEL

Description of Control Panel Main Board



The control panel main board contains electronic components sensitive to electric charges. Prior to installation, these charges must be removed. During installation, avoid touching any elements on the control panel main board.

BOARD TERMINALS:

AC	- module power supply inputs (17...24V AC)
Z1 to Z8	- zones
OUT1 to OUT4	- programmable outputs (current-carrying capacity 2.2A)
OUT5 to OUT6	- programmable outputs (current-carrying capacity 50mA)
+KPD	- keypad power supply output
+12V	- power supply outputs
COM	- common
DATA	- common terminal of keypads
CLK1 to CLK4	- individual terminals of separate partition keypads
⏏	- protective terminal - ground (connect to protective circuit only)
TIP, RING	- terminals of outside telephone line
T-1, R-1	- terminals of extension telephone line (telephone set)
J22	- connector for OUT5 & OUT6 output, power supply and ground lead-outs
J18	- connector for SM-2 voice synthesizer

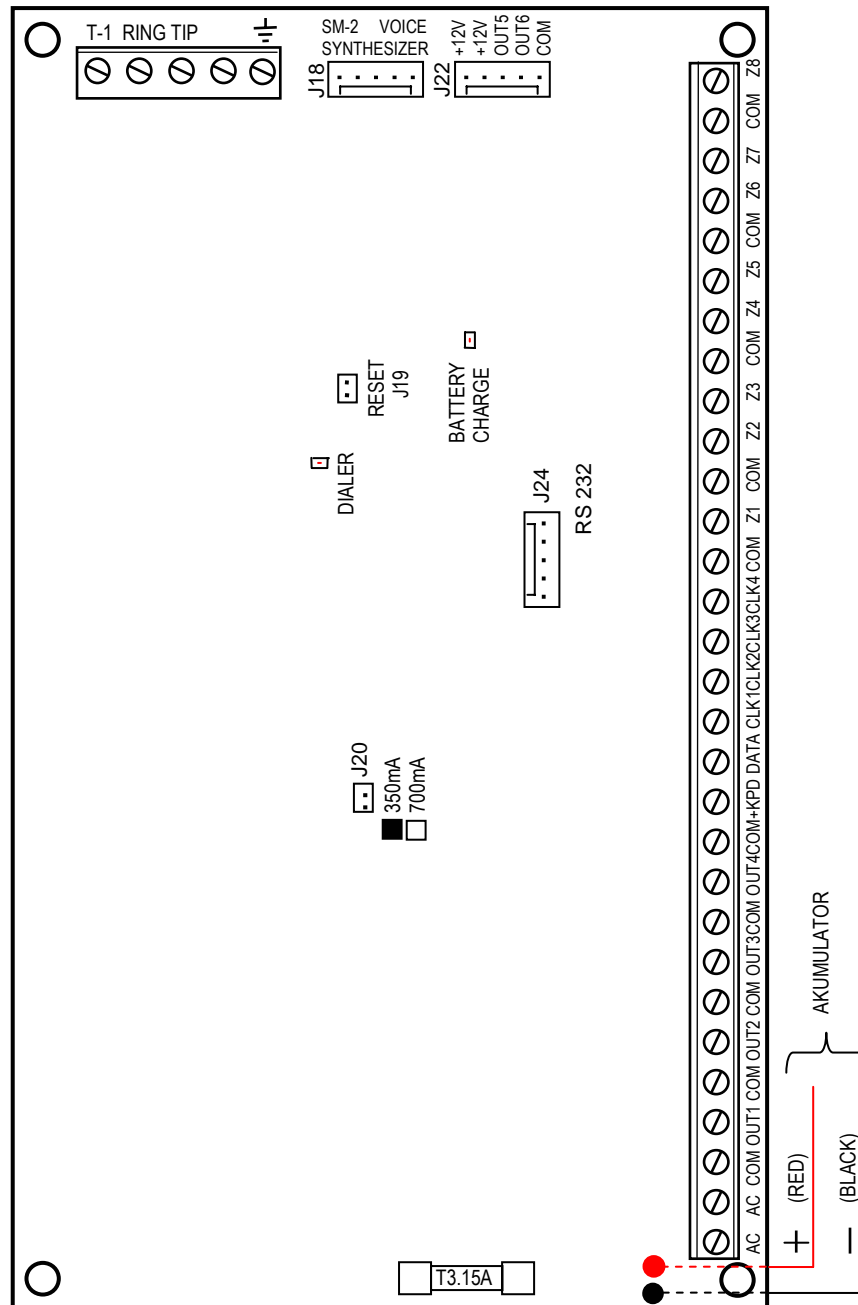

Figure 1. View of the control panel main board

The AC terminals are intended for providing the alternating supply voltage 17-24V from the AC/AC transformer.

The control panel is fitted with an advanced pulse-type DC power supply of high energy efficiency and operational reliability, however, its correct functioning requires that the input voltage at the **maximum load** of the transformer by the control panel does not drop below **16V AC**.

The CA-10 main board can be connected to an electric shock protection circuit (grounding). The protective cable terminal is designated by the \perp symbol. The „neutral” wire of the 230V AC mains supply must not be connected to it. If the facility has no separate electric shock protection circuit, this terminal must be left free.



The control panel power supply is fitted with:

- battery status monitoring system with optional disconnection of discharged battery,
- visual signaling of the battery testing/charging process (LED indicator on the main board),
- changeover battery charging current (350mA/700mA).

The stabilized voltage of the control panel power supply is 13.6 - 13.8V and is factory set.

The **BATTERY CHARGE** LED situated next to the „J19” pins is on when the battery status is being tested by the module and during charging of discharged battery. CA-10 tests the presence of battery every 10 seconds and every 4 minutes it tests (for several seconds) the battery status. During testing, the processor reduces the power supply and the loads are powered from the battery. If the battery voltage drops down to 9.5V, the control panel will cut off the battery in order to prevent it from a complete discharge and damage.

The **J20 pins** are used for setting the battery charging current:

350mA - pins shorted,

700mA - pins open.

Electronic short-circuit and overload protection is provided for each of the outputs OUT1-OUT4 and +KPD.

Attention should be paid so as not to cause overloading of the control panel power supply in the alarm system. It is advisable to make a **load balance** for the power supply. The total current inputs for the consumers (detectors, keypads) and the battery charging current may not exceed the power supply capacity. In case of a higher electric power demand, an additional power supply can be used for some of the security system consumers (e.g. APS -15, APS-30 manufactured by SATEL). Table 1 (at the end of this manual) shows an example of estimated balance of current consumption by the system, and an example of battery selection.

Two wires (red and black) are intended for connecting the battery, the red one is connected to the battery „+” terminal, the black one to the „-” terminal. The battery circuit is protected with a T 3.15A fuse.

The **J19 „RESET”** pins make it possible to start the service mode without entering any service code. This function can be disabled by the installer with software means (service function FS131).

The **„DIALER”** LED is on during telephone messaging by the panel, and blinks during pulse dialing of the telephone number.

The **telephone line** must be of a four-wire type so that the control panel can be connected before the other equipment (telephone, fax, etc.).

The CA-10 control panel should be installed in an enclosed space with normal humidity of air. The space should be fitted with an available permanent (not detachable) 230V power supply circuit with protective grounding.

The control panel can be mounted in the CA-10 OBU housing (this housing comprises a transformer designed for operation with the control panel power supply), which permits installation of a battery with 17Ah capacity. Before the housing is secured to the base, it is necessary to mount inside the housing plastic distance plugs, which are intended for subsequent installation of the main board.

In case the plugs tend to slip out, the catches fixing the plug in the housing need to be slightly bent aside (Figure 2). When inserting the plug, press the central part of the head firmly in so that it is blocked in the housing hole. It is advisable to make sure that the plug, when pressed, does not slip out from the opening. During installation of the housing, be careful so as not to damage the wires which will be passed through the hole in its back panel.

When the housing is secured, you can install the control panel main board and proceed to making the connections.

IMPORTANT: Do not connect the mains power supply and the **battery**, until all the remaining connections are completed.

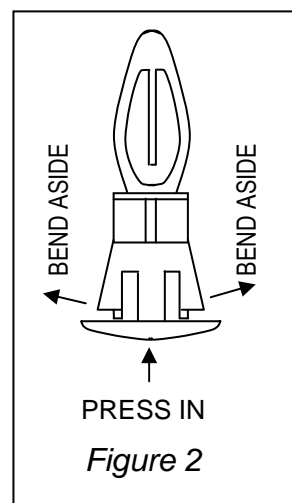

CAUTION!

The control panel is power supplied from 230V AC mains. Negligence or wrong connection may result in electric shock and pose a threat to life!

Therefore, be particularly careful when hooking up the control panel. In the process of installation and connection of the control panel, the cable to be used for mains supply must not be alive!

Connection of Keypads

The keypad is designed to operate indoors in normal humidity. It should be mounted straight on a flat surface. The spring provided on the tamper contact must adhere to the base so that the contact will open at an attempt to tear the keypad off the wall.

The control panel can operate both with LCD and LED keypads in any configuration.

Notes:

- *We recommend keypads: CA-10 LED M v1.2 and CA-10 LED S v1.2 or newer to be used, because older keypads LED M and LED S may work incorrect with keypad LCD v3.08 (and next version).*
- *Only zone expanders with version 2 are allowed (label dated February 1998 or later).*
- *The LCD display is fragile. It can be broken if the keypad is dropped to the floor !*
- *After power-up of the keypads LED-M and LED-S, and when the control panel quits the service mode, the keypad will remain disabled and will not react to pressing any keys for 5 seconds. During that time the system settings are being read, and the keypad backlight is blinking with a high frequency. Simultaneously, the keypad restores the automatic mode of keypad illumination. The mode can be changed with the user function by holding down the key [9].*

The keypads should be connected to the control panel connectors COM, +KPD, DATA, CLK1, CLK2, CLK3, CLK4. The connectors COM, +KPD and DATA are common for all partitions, while the connectors CLK1, CLK2, CLK3 and CLK4 determine the partition the keypad belongs to. Where the system will be operated with less than 4 keypads, they should be connected starting from the CLK1.

The keypads should not be connected in parallel to one CLK signal (one partition - two keypads). It applies to all LCD keypads, as well as the keypads CA-10 KLED-M and CA-10 KLED-S. The only exception are the CA-10 KLED keypads, which may be connected in parallel.

Each keypad should be connected with a separate cable. The distance between the keypad and the panel can be up to 200m. Unscreened cables are recommended to be used for connecting the keypads.

With a cable of the DY 8x0,5 type, the keypad-to-panel distances required to ensure correct power supplying can be as follows:

Distance	Connection	№ of cable cores	
		LCD keypad	LED keypad
up to 50m	Power supply & ground CLK & DATA signals	2 x 1	2 x 1
		2 x 1	2 x 1
50-100m	Power supply & ground CLK & DATA signals	2 x 2	2 x 1
		2 x 1	2 x 1
100-200m	Power supply & ground CLK & DATA signals	2 x 4	2 x 1
		2 x 1	2 x 1

The keypads may be power supplied from the +KPD panel connector only. This output can also be used for power supply of the keypad connected detectors, provided the total current will not exceed 1.5A.

As the LCD keypad current consumption is larger than that of the LED keypad (particularly with active illumination of the keypad and display), it is important that resistance of the power supply and ground lead-ins be taken into account when planning the cabling installation.

Caution: The supply voltage measured across the terminal block of LCD keypad with active backlighting should not be less than 11V.

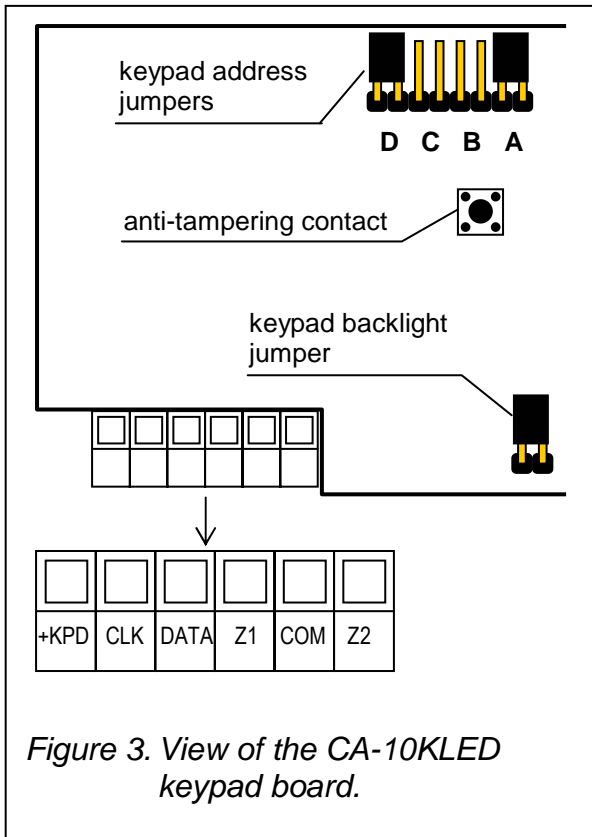

Figure 3. View of the CA-10KLED keypad board.

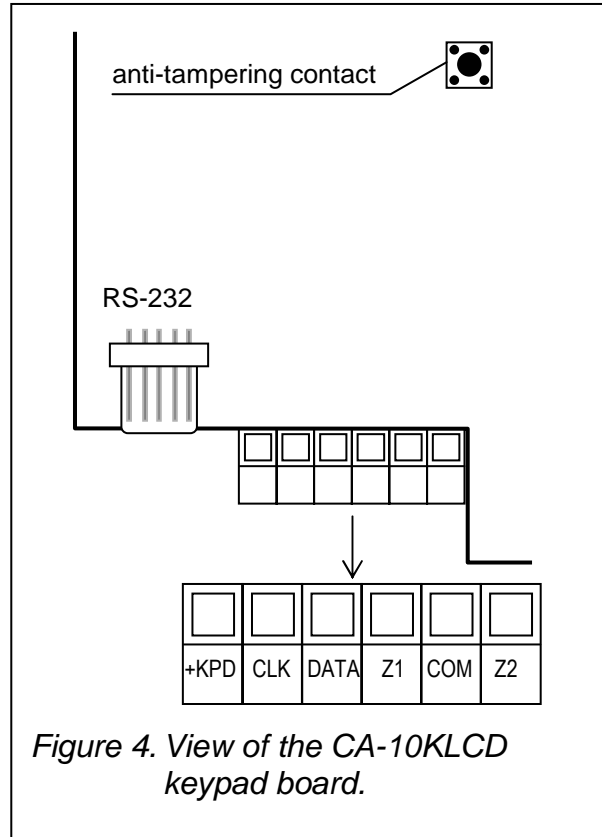

Figure 4. View of the CA-10KLCD keypad board.

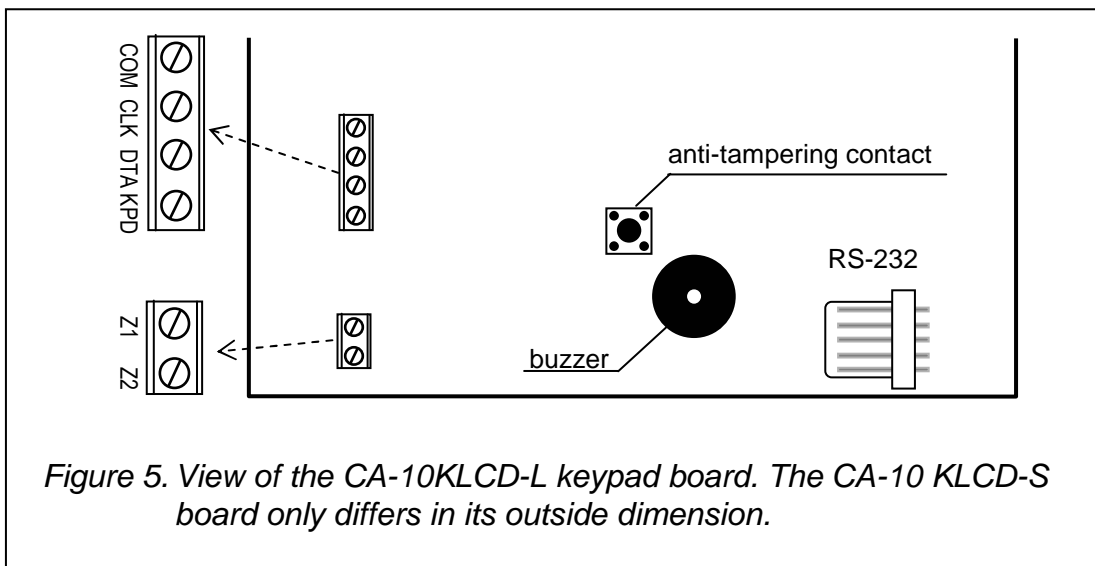

Figure 5. View of the CA-10KLCD-L keypad board. The CA-10 KLCD-S board only differs in its outside dimension.

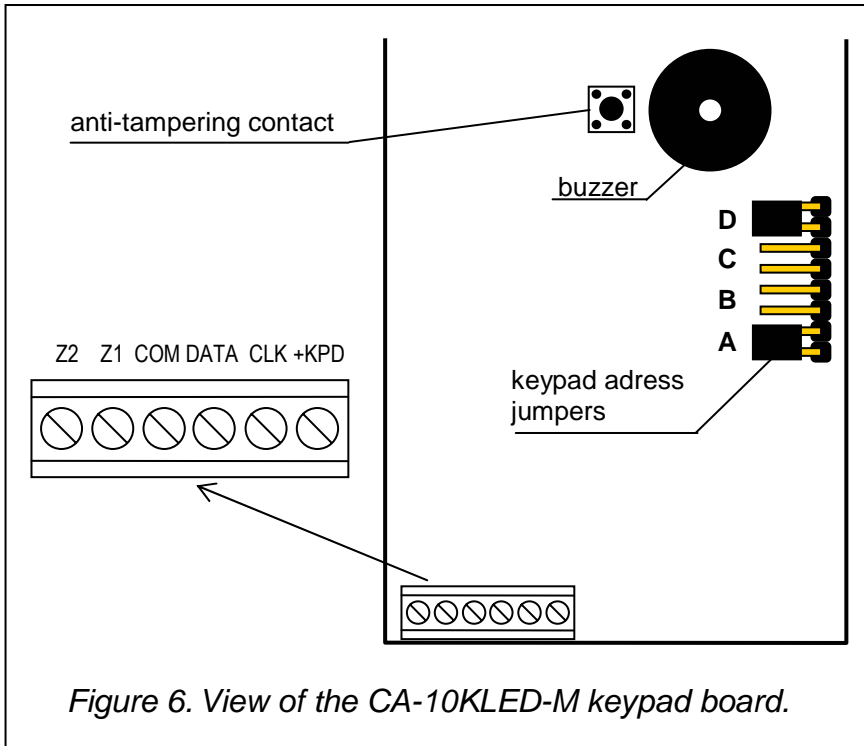

Figure 6. View of the CA-10KLED-M keypad board.

DESCRIPTION OF TERMINALS	
KEYPAD	PANEL
KPD	+KPD
DTA	DATA
CLK	CLK1 or CLK2 or CLK3 or CLK4
COM	COM
Z1 – to detector	Additional system zones
Z2 – to detector	

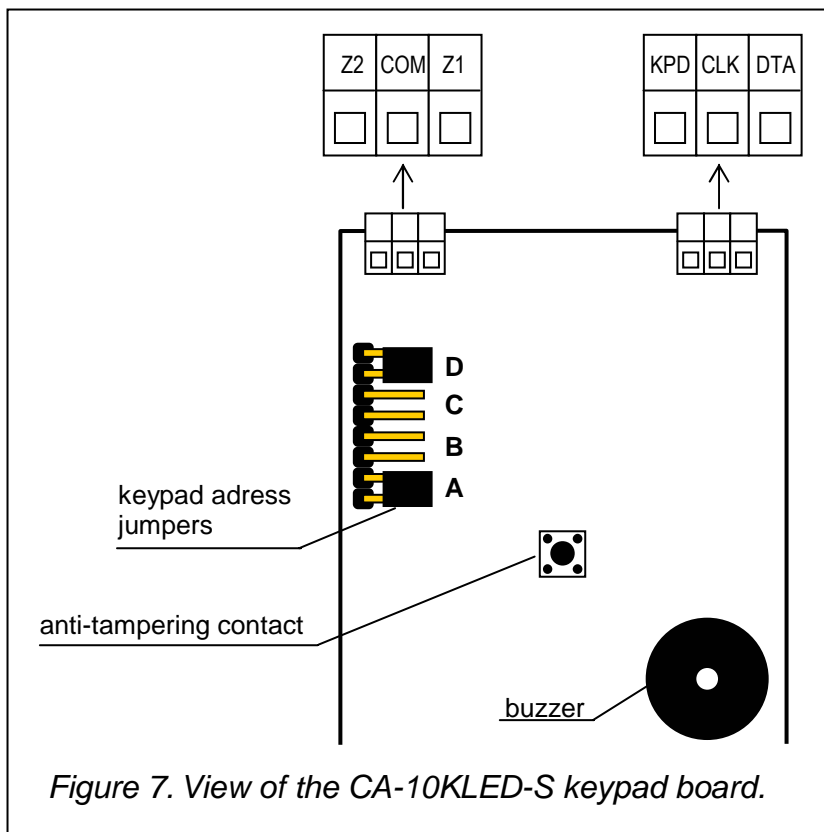
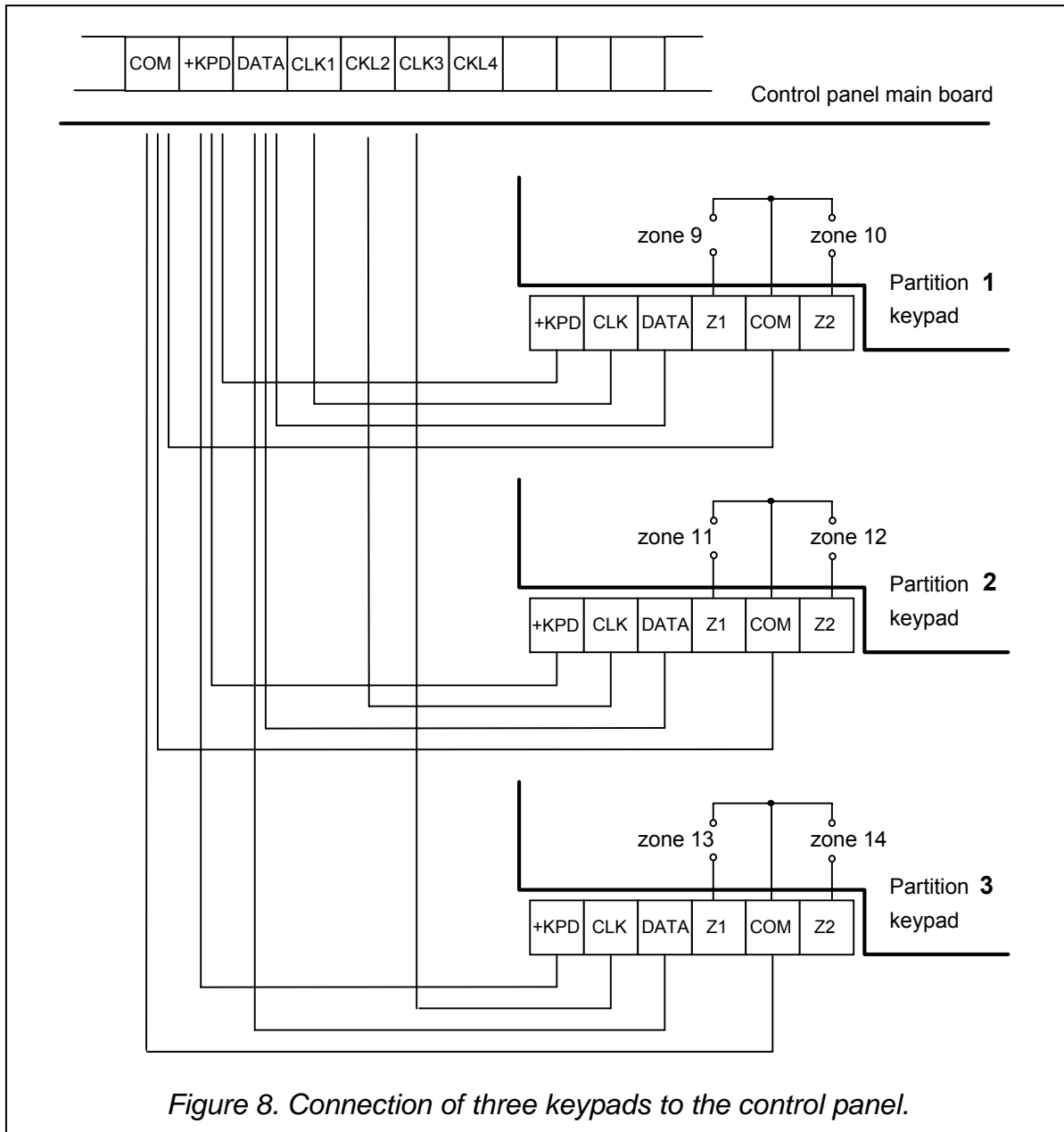

Figure 7. View of the CA-10KLED-S keypad board.

The keypad anti-tampering contact has no connection with the system anti-tampering circuit. Its state is defined by the control panel, based on the data received from the keypad. When the control panel is in the service mode, the anti-tampering contact is not controlled.

The keypad Z1 and Z2 connectors permit connecting any detectors. They are supported by the control panel in the same way as the main board zone inputs. The Z1 connector, partition 1 keypad, is recognized by the panel as zone 9, the Z2 connector, partition 1 keypad - as

zone 10, etc. Thus, with four keypads, the control panel has 16 zones. Alternately, a lower number of keypads and a zone expander can be used.



Setting Keypad Addresses

The address is keypad's additional anti-tampering safeguard. **A different (arbitrary) address should be set in each keypad.** To set an address in LED keypad, put jumpers on corresponding pairs of the ABCD pins (see figures: 3, 6, 7 and description of the service function FS111). In LCD keypad, the address must be programmed. The programming consists in entering four digits in binary code (by analogy with the LED keypads: 1=pins shorted, 0=pins open). The control panel does not support LED keypads in which either all jumpers or no jumpers are set, as well as LCD keypads in which the address 0000 or 1111 has been programmed. The address is stored in the panel EEPROM (non-volatile) memory, together with the other system parameters.

The LCD-keypad address can be changed in two ways:

1. Directly (skipping the service code):
 - Disconnect the keypad power supply and the data bus wires (CLK, DATA).
 - Short-circuit the CLK and DATA terminals of the keypad.

- Switch on the keypad power supply. The following text will be displayed: „Keypad hardware address: 1001” (the default value, corresponding to the jumpers read out in the ABCD sequence).
 - Using the [0] and [1] keys, enter the proper address and then press the [#] key. The „Address set” text will be displayed on the keypad.
 - Connect the keypad to the control panel in appropriate way (CLK, DATA).
2. By means of the keypad service functions:
- Activate the control panel service mode.
 - Select in turn the items in menu of displayed functions: →LCD keypad; →Settings; →Keypad address.
 - Using the [0] and [1] keys, enter the proper address and then press the [#] key. The keypad will display the text: „Set addresses (FS124) ? 1=Yes”.
 - Press the [1] key to automatically perform the FS124 service function and save the settings.

Note: For correct handling of the LCD keypads by the CA-10 control panel, the FS124 function must be performed on each of the LCD keypads connected to the panel.

It may turn out on starting the control panel that the keypad is not supported (no reaction to pressing the keys). A message appears then on the LCD keypad display that there is no communication with the control panel. This is usually because the keypad address is different than the one programmed in the panel. Depending on whether other keypads are also connected to the panel, or this keypad is the only one in the system, you can follow either of the two ways:

3. Call the service mode in another keypad and start the FS124 service function, which will result in correct keypad addresses being automatically read out by the control panel. In this case, remember to start the FS124 service function in all LCD keypads connected to the panel.
4. Enter the service mode by means of jumpers and program a correct keypad address in the control panel (see: *Starting the Control Panel*).

Connection of Zone Expander

In order to increase the number of zones, a zone expander can be connected, instead of a full set of keypads. It makes available the zones of keypads required for full configuration. The expander should be connected as a next keypad. It can be used in combination with a different number of keypads. For details regarding the connection see the expander installation manual.

The LCD keypads can only interface in the alarm system with the expander version manufactured since February 1998.

The expander address should be programmed as the address of consecutive keypads:

- second, third and fourth – if the expander is connected to CLK2;
- third and fourth – if the expander is connected to CLK3;
- fourth – if the expander is connected to CLK4.

Connection of Detectors

The CA-10 can operate with any type of detectors. Each zone of the control panel can work in the configuration:

- NC (normally closed),
- NO (normally open),
- EOL (End Of Line Resistors),

- 2EOL/NO (Double End Of Line Resistors, NO type detector),
- 2EOL/NC (Double End Of Line Resistors, NC type detector).

When the zone works in a EOL configuration, a **2.2 kΩ** resistor should be used to make the detector circuit.

With 2EOL zone, the detector circuit is closed by two **1.1 kΩ** resistors. The zones of 2EOL type enable the status of detector and its anti-tampering contact to be monitored at the same time.

The detectors may be power supplied from any of the electronically protected outputs (OUT1 to OUT4). The output should be programmed as the "POWER SUPPLY OUTPUT". Detectors connected to the keypad zones can be power supplied from the +KPD output, however, care must be taken so that the permissible load of 1.5A is not exceeded for that output.

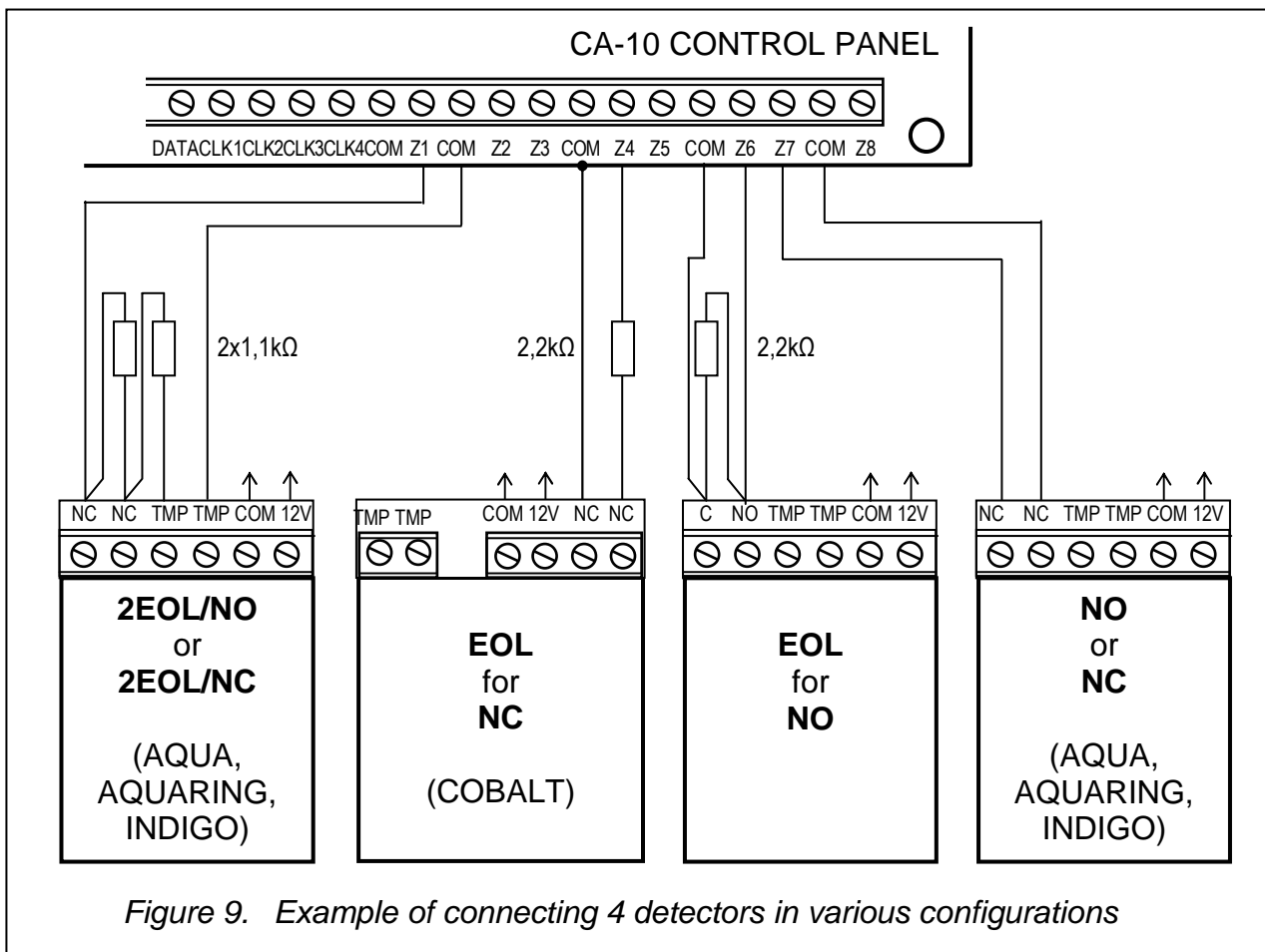

Figure 9 shows how the detectors should be connected to zones working in various configurations. Separation of the detector power supply ground and the line ground makes it possible to eliminate the harmful effect of wiring resistance. Assuming that the wire is rather short, and only one detector is connected to it, the installation can be simplified by using one wire for the power supply ground (GND) and the signaling ground (COM).

The NO and NC detectors in 2EOL configuration are connected in the same way, it is only important to correctly indicate to the control panel, what type of detector is connected to the zone input (2EOL/NO or 2EOL/NC).

Connection of Signaling Devices

Figures 10 & 11 show how the signaling devices should be connected.

The CA-10 panel can control signaling devices of any kind. Each of the panel outputs can perform any of 41 different functions. Therefore, the system is very flexible and can suit

almost every application. If there are signaling devices installed in the system, the alarm function will have to be assigned to corresponding outputs.

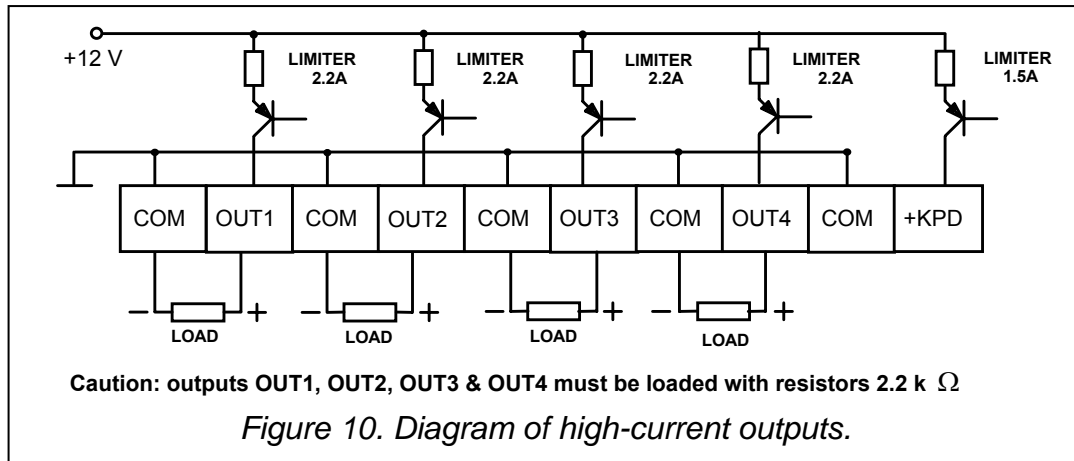

Where signaling devices are used that give alarm when energized, it is convenient to assign the alarm function to one of the outputs OUT1 to OUT4. If this is the case, the "+" of signaling device power supply should be connected to the control panel respective OUT output, and the signaling device "ground" - to the control panel COM connector. In this mode, even four independent signaling devices can be set. It is possible e.g., after programming one output for operation during a preset time, and the other for operation until cut off, to control the audible / visual signaling device.

The outputs OUT1 to OUT4 perform monitoring for the presence of a load. For their correct operation, the connected signaling devices must incorporate a parallel 2.2k Ω resistor. If there are undesired low sounds in disconnected signaling device, this resistor value should be reduced.

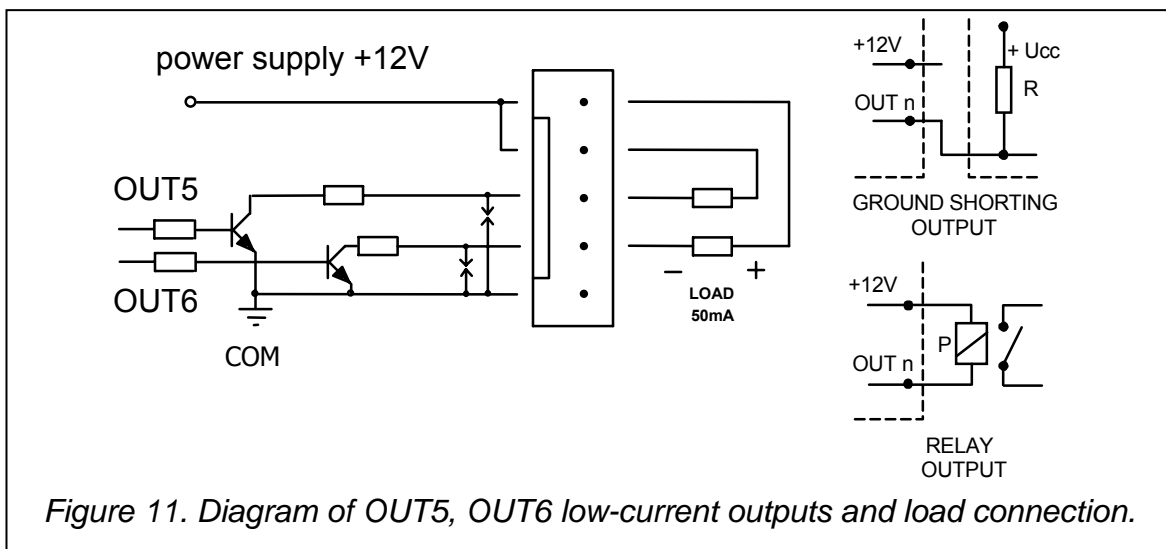

Where signaling devices with their own internal battery are employed, the OUT4 output can be used to power the signaling devices, and the triggering signals can be provided by the OUT5 and/or OUT6 low-current outputs.

The OUT5 and OUT6 outputs can be used to control the relays switching on any signaling devices or other equipment. The relays may be directly connected to the outputs, as shown in Figure 11.

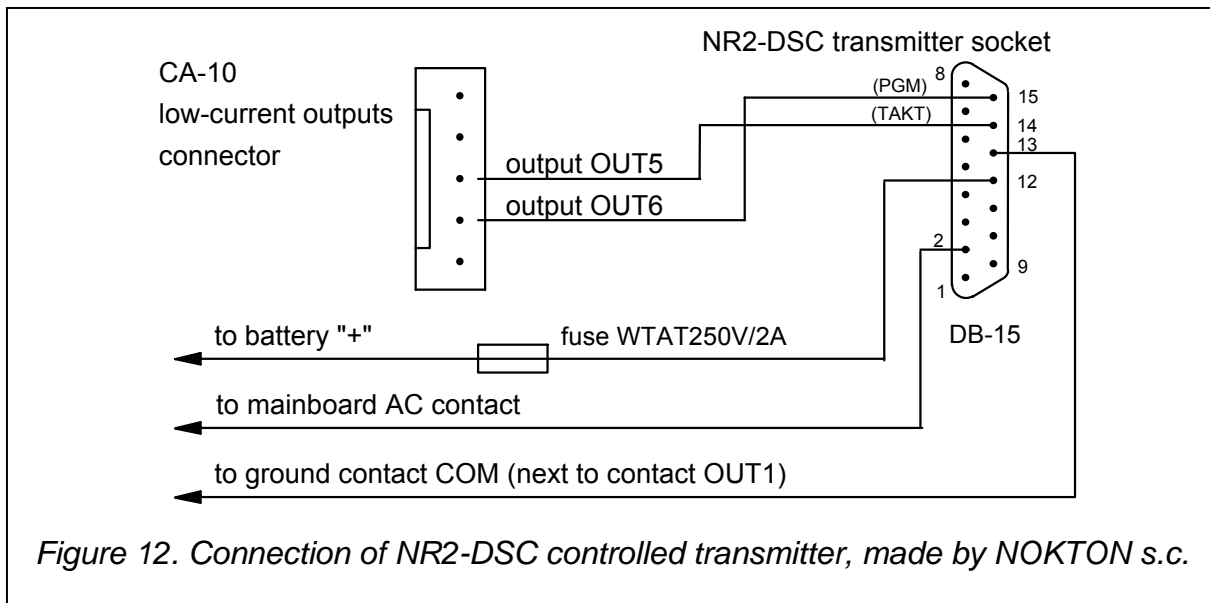

The OUT4 and OUT5 outputs can also be used to control the NOKTON NR2-DSC radio monitoring transmitter (NEMROD system - format PC16OUT). In such a case it is necessary to change the operating mode of these outputs by activating a suitable option in the service function FS5. During operation with the NOKTON transmitter, the outputs are used for transmitting a number of data on the control panel state (zone alarms, fire alarms, troubles, armed mode, etc.) and do not perform functions programmed with the standard service functions.

Note: When hooking up any equipment with a considerable current consumption (e.g. a radio monitoring transmitter) to the control panel, their "+" should be connected to the battery "+" (a fuse is recommended on the feeder cable). The ground must be connected to any COM contact of the control panel, but not directly to the battery "-". If connected to the battery "-", the ground will actuate the charging current limiter, eventually causing quick discharge of the battery.

Connections of Telephone Line

If the control panel telephone communicator is used in the alarm system (for monitoring, messaging or remote programming), it is necessary to connect telephone line to the control panel. It should be led to a connector situated on the right side of the printed board. In order to ensure proper messaging, the control panel **must** be directly connected to the line (connectors designated as TIP and RING), and any other devices (telephone, telefax) - after the control panel (connectors designated as T-1 and R-1). Such a connection will make it possible for the control panel to fully engage the line for the time of calling, which prevents the messaging function from being blocked by lifting the handset. Additionally, the telephones connected after the control panel do not signal the dialing by the control panel.

CAUTION!

- Do not send telephone signals and alarm system signals by one multicore cable. This may result in a damage to the system in case of a high-voltage punch-through from the telephone line.
- Telephone terminals of the panel should be connected to PSTN lines only. Connecting to ISDN lines may lead to damage of the equipment.
- System installer should give the necessary information on the way of connection with telephone network to system owner.

Connection of Voice Synthesizer

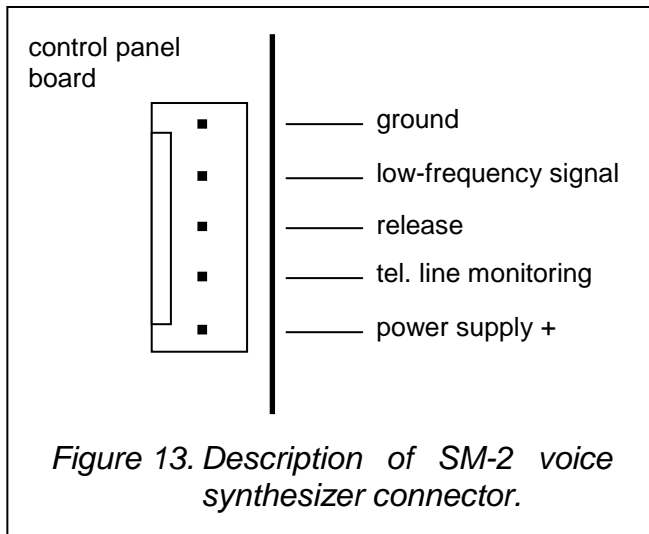

Where the function of alarm messaging with voice announcements is used, a voice synthesizer must be connected to the control panel.

The CA-10 panel interfaces with the SM-2 synthesizer. The synthesizer socket (designated as: SM-2 VOICE SYNTHESIZER) is situated on the right-hand side of the printed board, between the telephone line connector and the socket of OUT5, OUT6 outputs. The SM-2 synthesizer should be directly plugged into this connector. It is fitted with minijacks for playback of the message and "monitoring" of the telephone line.

Connection of Printer or Computer

If a detailed documentation of events occurring in the alarm system is required, a printer must be connected.

The printer can be connected either permanently or just for printing the event log. When the printer is connected permanently, all the events occurring in the system are printed instantly. The printout line includes the date, time, description and source of the event (zone number, partition number or user number).

The control panel is designed to control printers having an RS-232 input. On the control panel board, the RS-232 port is linked to the J24 connector. The control panel RS-232 port also enables the panel to be connected to the computer. For programming the CA-10 control panel via the RS-232 serial port you can use a cable identical to that used for the CA-64 panel.

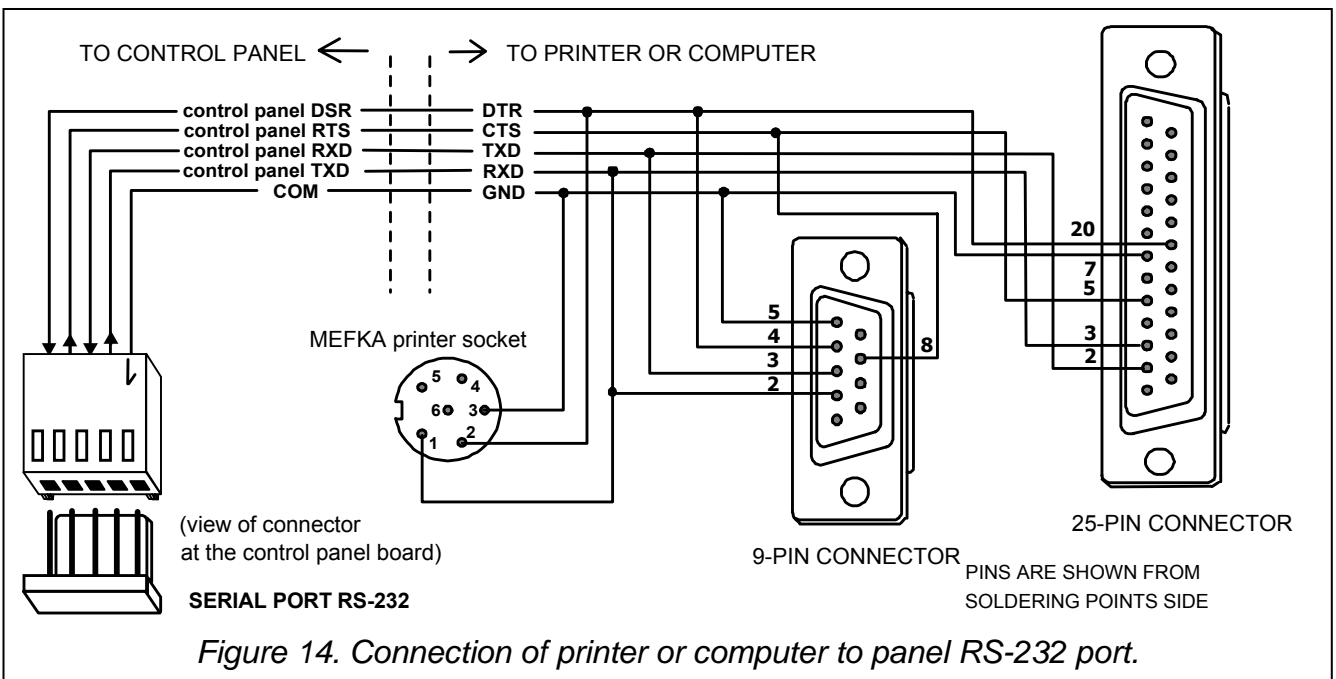

The arrangement of signals and the hookup of printers or a computer to this connector are shown in Figure 14. As a rule, the panel TXD signal is supplied to the printer RXD input, and the printer TXD signal to the panel RXD input. The printer notifies the panel with a DTR

signal of its readiness to receive data. Lack of this signal is reported by the panel as a trouble of the RS-232 port.



Notes:

- Do not short or touch the serial port RS-232 pins with your fingers.
- Prior to connecting the cable, the installer should remove the electrostatic charge, e.g. by touching a grounded equipment (faucet, heater, etc.). with the top of his hand.
- It is recommended that the cable be connected first to the control panel connector, and then to the computer or printer connector.
- The cable connecting the RS-232 ports may be up to twenty meters long.

After starting the DLOAD10 proprietary program (on the included floppy disk), selecting the appropriate communication port (CONFIGURATION window) and activating the **FS112** service function in the control panel, it is possible to program the control panel from the computer.

Connection of Power Supply

The control panel is permanently connected to the mains power supply. Hence, before you start to work on the system cabling, make yourself familiar with the electrical installation in the facility. In order to power the control panel, select a circuit where voltage is always present. This circuit should be protected with an appropriate fuse.

CAUTION!

Before connecting the control panel to its power supply circuit, you must turn off voltage in that circuit.

Description of electrical connections to the CA-10 OBU housing

1. Connect the 230V alternating voltage leads to the transformer terminals marked "**AC 230V**".
2. Connect the output voltage wires of the transformer secondary winding to the "**AC**" (~18V) terminals on the control panel main board.
3. Connect the wire of the PE electric shock protection circuit to the terminal block situated next to the transformer and marked with the ground symbol . This circuit should also be connected to the control panel protective terminal.



Do not connect the "neutral" wire of the 230V AC mains supply circuit to the ground terminal. If there no separate electric shock protection circuit in the facility, this terminal should be left free.

Control panel power-up starting procedure

1. Connect the emergency power supply wires to the corresponding battery terminals (the red one to the battery plus, the black one to the minus). **The control panel will not start on connecting the battery alone** (without the mains power connected), however, it will keep on working in case of the 230V AC voltage trouble, provided it was already started.
2. Switch on the 230V AC mains supply – the control panel start follows.

Connection of the power supplies in the prescribed order will permit correct functioning of the power supply unit and the control panel electronic safety devices, thus avoiding damage to the security system elements caused by possible installation faults.

Note: If it is necessary to completely disconnect the control panel power supply, the 230V alternating voltage should be disconnected first, then the battery. Re-connection of the

power supply is to be performed in the above mentioned order (the battery first, then the 230V alternating voltage).

Caution !

As the control panel has no isolating switch to disconnect the mains supply, it is important that the owner or the user of the security system be informed on how the system is to be disconnected from the mains (e.g. by indicating the fuse which protects the control panel supply circuit).

Starting the Control Panel

When all electrical connections are made and checked for correctness, you can proceed to starting the system. It is recommended to begin the work with the control panel with no signaling devices connected, as the load can exceed capacity of the power supply unit, thus making start of the control panel impossible. The signaling devices can be connected after programming parameters of the realized alarm system is completed.

If the control panel operates with one keypad, having a default address (1001 - jumpers on pins „A” and „D”), then, after the power is switched on, the keypad will report readiness for work with four short beeps followed by a long one.

Note: *The control panel with default settings will not support a keypad connected to the CLK1 signal if the default address (1001) has been changed in that keypad.*

If the control panel is alarming after power-up, clear the alarm by means of the user access code (default master code for partition 1: [1][2][3][4]) and proceed to programming parameters in the service mode.

Upon entering the default **service code** [1][2][3][4][5] and confirming it with the [#] key, the control panel will enter the service mode. The ALARM and ARMED LEDs (PARTITION in the LCD keypad) will be blinking alternately. Now, you can proceed to programming the control panel.

Note: *For the safety reasons it is recommended that the keypad default address be changed. Having done the changes, you must run the FS124 function.*

If the system includes more keypads or where the zone expander is installed, the control panel will not support any devices connected to the signals CLK2, CLK3, CLK4 until their addresses have been programmed in the control panel memory.

Hardware Access to the Service Mode

If the panel does not „see” the keypad when the power is on, and does not respond to the keystrokes (access code entry), or keeps on alarming, it is necessary to carry out the procedure of **hardware access to the service mode**. This allow to program of the keypad / expander addresses before the normal operating mode is restored. In the other case, the control panel will start alarming right after the power-up because it has detected the keypad tampering.

To start the service mode by means of jumpers follow the procedure below:

1. Disconnect in turn the mains supply and the emergency supply.
2. Check the keypad address jumpers and anti-tampering contacts for correct settings.
3. Put a jumper on the control panel RESET pins (J19).
4. Connect in turn the emergency supply and the mains supply.
5. After the keypad beep, remove the jumper from the RESET pins (J19). The operation will activate the service mode in partition 1 keypad. This will be signaled by the keypads with four short and one long beeps.

6. Call the service function FS124. The function automatically reads the keypad address and prepares the control panel for work in a new configuration.

Note: *If LCD keypads are installed in the alarm system, call the FS-124 service function in each LCD keypad. When activated from the LCD keypad, this function automatically performs additional configuring operations and its activation in each LCD keypad is necessary for proper operation of the system.*

7. To make sure that all the settings are in accordance with the default values, you can perform the service functions FS107, FS108 and FS110.

Having completed the procedure, exit the service mode using the function FS0 and activate the service mode again - this time from the keypad - by entering the default access code [1][2][3][4][5] confirmed with the [#] key.

If the control panel has re-entered the service mode, it means that its functioning is correct and that you may proceed with further installation of the system (connection of sensors, signaling devices, establishing communication with a computer, if required) and programming of all necessary parameters.

If the described procedure is unsuccessful, the option of hardware access to the service mode must have been disabled in the control panel by software means. If this is the case, it is necessary to carry out another procedure which would **enable the control panel** and restore the default settings:

1. Disconnect in turn the mains supply and the emergency supply.
2. Set a jumper on J19 RESET pins.
3. Connect in turn the emergency supply and the mains supply.
4. Wait about 60 seconds (± 5 sec.) and remove the jumper.
5. Enter from keypad the code: [1][2][3][4][5] (the code should be entered within 15 seconds) and confirm by pressing the [#] or [*] key.

Programming the Control Panel from the Computer

Programming the control panel from the computer via the RS-232 port should be initiated by calling the service mode and the **FS112** communication function in the control panel. Provision is also made for starting communication without calling the function **FS112** - which is convenient if the control panel is already installed on the site and there is no keypad in the vicinity. In order to start communication without the use of keypad do the following:

1. Disconnect in turn the mains supply and the emergency supply.
2. Connect the cable to RS-232 ports in control panel and computer (Fig.11).
3. Start the DLOAD10 program in the computer.
4. Select in the program the communication port to which the cable is connected.
5. Select in turn the following functions from the program menu: →Communication; →Local connection with...; →CA10 (RS-232, without the use of keypad).
6. Follow the messages displayed by the program.

ACTIVATING SELECTED FUNCTIONS

Performance of some functions of the control panel requires that a few to more than a dozen parameters be programmed simultaneously. This section contains detailed information on how to program such functions as: telephone messaging, monitoring and downloading.

Guard Control Function

The functioning of the guard control function consists in automatically checking that the, so-called, guard code is entered on the keypad with a preset frequency. The entry of the code is saved in the log event, and so is the trouble to enter the code after a preset period of time, which can be signaled on an output which has the proper function. These events can be reported to the monitoring station.

To activate the function you must:

- program the guard code - in the user function 2 (creating new user) a code with authority level 5 (instead of the guard code, the user function 7 can also be used - activation of the „switch MONO" output)
- set a suitable timer to perform the „partition monitoring" function (FS106)
- program the timer control time (functions FS102÷FS105, depending on the partition).

Telephone Messaging - Alarm Reporting

The telephone messaging function requires that the following be programmed:

- **FS5, FS131** – activate the “telephone messaging” option, set the “dialing system” option as required by the telephone exchange,
- **FS87 to FS94** - enter at least one telephone number,
- **FS95** – define the partitions from which alarms are to be reported to the telephone numbers programmed in functions FS87-FS90,
- **FS100** – number of telephone messaging queues higher than zero and number of redials in a queue.

Note: *You should also program in FS95 what kind of message will be sent - if no message is selected for the pager, the control panel will notify with a voice message from the voice synthesizer.*

When the above parameters are correctly programmed and the alarm is triggered, the on-board LED (designated as „DIALER”) should go on, which indicates that the panel has started telephone messaging (with pulse dialing the LED is blinking). It is recommended to test the messaging. To this purpose, use the ordinary headset connected to the „telephone line monitoring” jack in the SM-2 synthesizer (parallel connection of a telephone set to „monitor” the communication will interfere with the messaging operation). The telephone messaging will start immediately after triggering the alarm. Alarm clearing will interrupt the telephone messaging.

Typical problems with starting the voice messaging:

- **control panel takes no attempts to call** – not all of the above mentioned items were programmed ;
- **control panel goes on line but fails to dial** – no dial tone or a non-standard dial tone from the telephone exchange – find out the cause of missing signal or deactivate the dial tone test option in FS5 if the signal is non-standard;
- **control panel establishes connection, but sends no voice message** – wrongly programmed FS95 – messaging to pager selected, but not voice message from the synthesizer;
- **control panel establishes connection, sends a message too early or too late** – the control panel recognizes answering the call on the basis of sound signals on the telephone line, with permissible message sending delay up to 4 seconds from lifting the handset - if commutation signals on the telephone line are non-standard or there is strong interference (clicks, hum), the panel automatic equipment may not function

properly – then you can extend the message by activating the “double message” option in FS5 or deactivate the call answer recognition option;

- **control panel reports the alarm more times than the preprogrammed number of queues** – the control panel recognizes answering the call on the basis of a callback signal – if the user lifts the handset too quickly (during the first ring), the control panel may disregard the message and call again.

Reporting to Telephone Monitoring Station

The monitoring station operator should provide the installer with the data necessary for the monitoring software. These are:

- monitoring station **telephone numbers**;
- **transmission format** or a list of available formats;
- alarm system **identifier** (facility number - one or more for detailed reporting from a big system);
- **list of event codes.**

In order to start monitoring, the following items should be programmed:

- **FS43 – monitoring station telephone number** - if there are two numbers or two stations, the other number should also be programmed in FS44.
- **FS45, FS46 – station transmission formats** - in case of a multi-format station, select format which is as fast as possible (e.g. Ademco Express or Radionics 2300 with parity).
- **FS47 – monitoring options.**
- **FS48 to FS59 – monitoring stations identifiers**, an identifier should have 3 or 4 non-zero characters (characters from “1” to “F”, “0” - no character), some stations use identifiers composed from digits from 0 to 9 - then character “A” is to be programmed instead of digit “0” (e.g. “A1A2” instead of “0102”).

At least three identifiers should be programmed (can be identical):

- zone identifier,
- partition identifier,
- system event identifier.
- **FS60 to FS66 & FS69 to FS72, FS81, FS82, FS126 – event codes** according to the list from the monitoring station operator, the codes can be one-digit (the other character being 0) or two-digit - as required by the station, the codes with inappropriate length may block communication with the station.
- If reporting with event sorting to both stations has been selected in the options, events assignment should be programmed in the functions FS67-FS68, FS73-FS80, FS83, FS84.
- **FS5 - activate the option “Monitoring”** after the above items have been programmed.

Typical problems with starting the monitoring:

- **Control panel takes no attempts to call** – not all of the above mentioned items have been programmed – the control panel will not call the monitoring station if the programmed data do not allow sending a correct transmission to the station because of e.g. missing telephone number, identifier being shorter than 3 non-zero characters, missing event code, etc.
- **Problems with dialing** – no dial tone or a non-standard dial tone from the telephone exchange – find out the cause of missing signal or disable the dial tone test option in FS5 if the signal is non-standard.

- **Control panel sends no codes when connected to the station** - wrongly selected format or low quality of telephone connection (the panel does not “understand” the station dial tone);
- **Station does not receive or acknowledge the codes sent by the panel** - wrongly selected format, inadequate identifier length (3 characters, while the station requires 4), inadequate event code length (1 character, while the station requires 2) or low quality of telephone connection.
- **Control panel does not send codes of some events**, despite of the codes being properly entered - identifier of the particular group of events is missing, e.g., if the partition 1 identifier is missing, no reports on this partition arming / disarming will be sent.
- **Control panel automatically changes the option „transmission to Station 1 or to Station 2” into transmission to one station only** - if with this monitoring option selected the number of identifiers for Station 1 and Station 2 is different (there are codes which have an identifier for one station, but not for the other), the panel cannot report to both stations in the „Station 1 or Station 2” mode and will change the option for transmission to the station which has a larger number of identifiers.

Note: For the Ademco Express transmission format the identifier „0000” is correct (sending "zero" is possible), while for the other formats it means no identifier ("zero" is not sent).

A headset connected to the "telephone line monitoring" jack in the SM-2 synthesizer can be helpful in analyzing the problems with communication to the monitoring station

Connection with the station is established in the following way:

- the station answers the call and sends the, so-called, handshake signal (one or a few in sequence if the station supports several transmission formats),
- the control panel recognizes the station handshake signal and if it matches the programmed transmission format, the control panel answers by sending identifier and event code in appropriate tones (once or twice, depending on the selected format) – in the headset connected to the line monitoring jack, these sounds are much louder than the monitoring station signals,
- if the station receives information, it will acknowledge it with the same signal as the handshake,
- the panel disconnects or sends next codes if there still are some other events to be reported to the station.

The most common monitoring problems result from inaccurate information on the transmission formats supported by the given station (e.g., ambiguous names of the formats), errors in the data entered into the control panel, as well as poor quality of the telephone connections. Often only by “monitoring” the course of communication you are able to find the cause of a problem.

Note: Some stations do not acknowledge reception of the event code if it has another format (e.g., 4/1 instead of the required 4/2). If this is the case, the control panel will repeat its attempts to establish communication, while telephones in the facility will be disconnected - the costs of such connections may be very high. For this reason, it is recommended that all the programmed codes be very carefully checked. It is possible to activate the options 7 and 8 in FS-47, which makes the panel omit the codes unacknowledged in 16 consecutive retries. Problems of this type do not occur in professional, multi-format monitoring stations (including the Satel STAM-1).

Downloading - Telephone Communication with the Computer

Telephone communication with the computer requires a modem. The modem must meet two essential conditions:

1. enable operation in the transmission format UTI V.21 (CCITT V.21) or BELL 103 (operation at a rate of 300Bps on telephone line),
2. permit operation to be configured **only** in one of these formats (the function of automatic format negotiating disabled).

Before starting the first connection between the computer and the control panel, appropriate settings must be entered in the DLOAD10 program (CONFIGURATION window). Information on the modem configuration is contained in the DLOAD10 program „HELP” file (function activated with F1 key), topic: “COMMUNICATION” and in chapter “PROGRAM CONFIGURATION FOR COMMUNICATION WITH THE PANEL” of this manual. In the case of non-standard modems, you must refer to the modem manual for the information on configuration procedures.

Modem initialization

The program initializes the modem after the „MODEM” item is selected from the „COMMUNICATION” menu. In case of any trouble, the program will display one of the two messages:

- MODEM NOT RESPONDING which means a technical problem with communication with the modem, e.g. an incorrect COM port number, conflict with the Windows system drivers;
- BAD COMMAND – wrong command initializing the modem.

Correct initialization of the modem does not mean it is properly configured to work with the control panel. The first initializing commands, as suggested in the program, are sufficient for a correct operation of most older-generation modems (i.e. modems with a maximum speed of 2400Bps). The fast modems of a new generation **require** some extra commands being added to limit their operation speed.

Remote communication procedure:

- program in the control panel:
 - **FS2**: control panel identifier by which the program recognizes the alarm system
 - **FS3**: computer identifier by which the control panel recognizes the computer authorized to establish connection
 - **FS4**: computer telephone number (which is not necessary)
 - **FS5**: “external DOWNLOADING” option, “double call” option (any setting) and the **FS101** – number of rings before answer – if communication is to be initiated from the computer
- start the DLOAD10 program, select the CA-10 control panel (CA10v1, 2, 3, 4) - program version 4 corresponds to the CA-10 panel, e.g. by opening the data of such a panel and, select the “MODEM” item from the „COMMUNICATION” menu.

Note: *The communication identifiers and the „double call” option settings must be identical in the control panel and in the alarm system computer data.*

Telephone connection with the control panel will be set up automatically after selecting any communication command in the program (Read, Write, Event log read, ON-LINE mode). You can also start communication from the panel with the user function 0.

Telephone communication error messages:

- “**modem not responding**” – the modem has not acknowledged the dialed number (a rare case, usually a problem caused by modem hardware or e.g. missing the “V1” initializing command),

- “panel not responding”, “no panel's carrier”, “no panel's initial greeting” “insufficient line quality or bad PC's communication password!”, “panel's communication password does not match PC data”
 - connection with the control panel was unsuccessful,
 - the control panel was off hook but did not answer the modem signal because it was much corrupted,
 - the control panel was off hook but did not answer the modem signal because it was not in the transmission format V.21 or BELL 103 (incompatible or incorrectly configured modem),
 - the control panel established connection, but the identifiers in the control panel and computer are different - the panel disconnects,
- “connection interrupt” – the control panel stopped answering the computer signals.

Note: If the control panel answers the call but fails to establish communication and disconnects, while the “double call” option is deactivated, it will be answering no calls for the next 5 minutes.

Programming the LCD Keypad from the Computer

Programming the LCD keypad data is only possible in the local mode. You can program the following data:

- keypad options;
- names of zones, partitions and outputs;
- message contents;
- user names.

Note: The names contained in the data of the first partition LCD keypad are used as descriptions when scrolling through the event log.

In order to program the data you should:

- connect the RS-232 ports of keypad and computer with a corresponding cable (identical as in Fig. 14),
- start the DLOAD10 program in the computer and select the COM port to which the cable is connected (see: *Program configuration for...*),
- open the file with alarm system data,
- open the *LCD keypads* window and select the corresponding keypad (tabs: LCD 1...LCD 4),
- start the data readout by clicking on the *Read* field on the right-hand side of open window (the correct readout operation is confirmed by the status bar indicator at the bottom of the window),
- enter the data in the corresponding fields of the computer screen,
- save the data in the keypad memory by clicking on the *Write* field just below the *Read* field,
- disconnect the cable from the keypad RS-232 port,
- repeat the programming operation for the other LCD keypads in the system.

REMOTE PROGRAMMING – DLOAD10

The DLOAD10 program delivered with the control panel is designed for programming the CA-5, CA-6 and CA-10 panels, as well as the RX2K, RX4K radio controllers and GSM-4 module,

from the computer. Additionally, the program makes it possible to create documentation of alarm systems, sets of settings for various configurations ("patterns" which facilitate the programming of new systems), event sets for each system, as well as to remotely operate the control panel in the same way as with the keypads.

The program is designed for IBM PC/AT compatible computers. It works in any computer hardware configuration in the **WINDOWS** (9x/ME/2000/XP) environment. It is recommended that the program be installed on the computer hard disk.

The control panel communicates with the computer through the RS-232 interface or via the telephone line. For telephone communication with the panel, the program uses a modem controlled by one of the COM ports (internal or external), compatible with the HAYES "AT Command" standard. Communication with the control panel is possible in the **CCITT V.21** or **BELL 103** standard (at 300 Bps). As the control panel transmits data only with a speed of 300 bauds, the modem must support this speed of operation.

Usually a suitable modem configuration is necessary - disabling the transmission standard negotiating function and forcing the transmission speed of 300 Bps.

In order to install the program, run the **D10setup.exe** program from the floppy disk which is delivered with the control panel. The installation completed, start the program. Access to the program is protected with an **access code**. After installation, the code is **1234** and can be changed to any sequence of 16 alphanumeric characters. As long as it has its factory form, you can start the program (with default code 1234) by pressing the „ENTER” key (no access code need to be entered).

Having started the program, configure and initialize the work of RS-232 port or modem by means of which the control panel will be programmed. By default, the program opens a window which enables the CA-10 panel to be programmed. Your next step can be starting the connection (either remote or local).

A HELP system is provided which facilitates operating of the program, as well as the very programming of control panel parameters. The system is accessible from the „**HELP**” menu, or by pressing the **F1** key on computer keyboard. To get an instant access to more detailed information, first select the required element in the program window (by moving the mouse pointer to and left-clicking on it), and then press the F1 key.

Program configuration for communication with the panel

In order to begin configuration, click on the  icon to open the „Configuration” window. **The „Port RS-232” tab permits selecting the computer port number in the case of direct programming through the panel RS port.** If the control panel is being programmed by means of the modem, select the „Modem” tab and click on the „Details” button.

After opening the „**Modem**” window, select the corresponding modem type or click on the „**! Change**” button to enter data according to the documentation of your modem. Entering a new name and initialization path, and confirming it with the „**OK**” button makes it possible to add new settings to the list of modems. After clicking on the „! Change” button you can also change the communication port number and the maximum transmission rate.

The „**✓ Test**” button permits checking interaction between the modem and the program – it opens a window containing information on modem initialization.

Having properly initialized the operation, close the configuration windows.

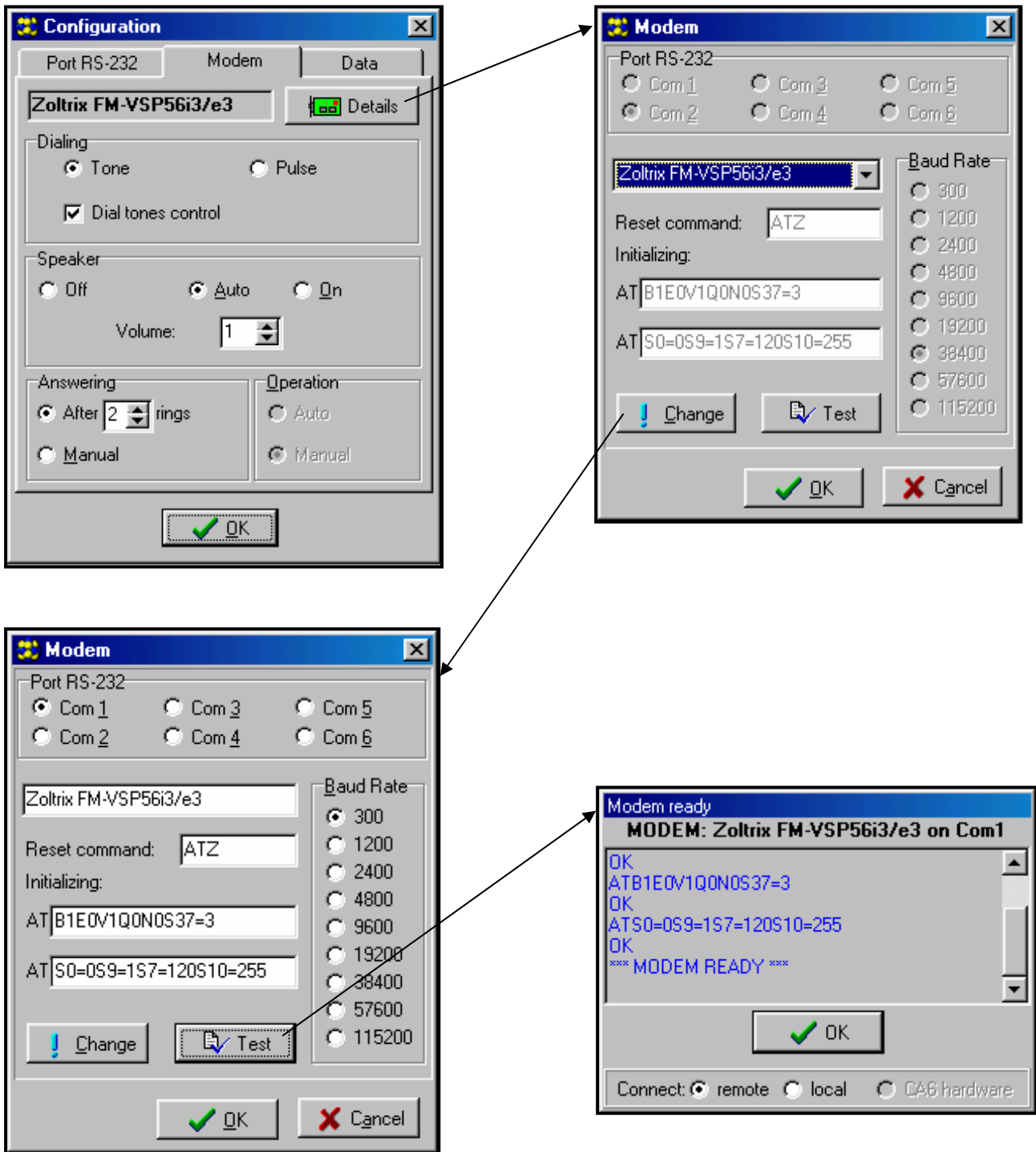



Figure 15. Dialog boxes in DLOAD10 program.

In order to start communication through the RS port, follow the instructions contained in section „Programming the control panel from the computer”.

The modem communication can be started by clicking on the  icon (or selecting the „MODEM” command from the „COMMUNICATION” menu). The program will open a dialog box enabling connection to be established and will prompt the further course of action. For details see the section „Remote programming - DOWNLOADING”.

The type of control panel is recognized automatically on establishing connection, or can be selected through the “File” menu.

Calling the function of reading the control panel data (icon ) after the communication has been established may speed up the subsequent process of saving the changes made in the control panel programming.

DEFAULT SETTINGS

Control panel configuration (restore with FS 107 function):

- one partition including all the available zones (Z1 to Z10),
- zone 1 (Z1) - ENTRY/EXIT function, EOL (End Of Line Resistors),
- zones 2 to 8 (Z2 ... Z8), 9, 10 (Z1 & Z2 in partition 1 keypad) – INSTANT function, EOL,
- zones 11 to 16 - not used,
- sensitivity of all zones – 0.48 sec.,
- PRIORITY option activated for all zones (FS 27, first option),
- other zone options deactivated, detector operation testing disabled,
- output OUT1 - BURGLARY ALARM function, operation time equal to global time, polarity +12V, assigned to all zones (audible signaling),
- output OUT2 - BURGLARY ALARM function, operation time before cleared, polarity +12V, assigned to all zones (visual signaling),
- output OUT3 - detectors power supply,
- output OUT4 – not used,
- output OUT5 - READY STATUS function (for all zones),
- output OUT6 - TELEPHONE USAGE STATUS function (OUT5 & OUT6 output functions are connected with testing the panel during production process),
- partition 1 keypad displays all zones available, no automatic zone bypasses, all functions available, disabled audible trouble signaling only,
- all options deactivated (telephone messaging, monitoring, telephone answering, etc.),
- all data related to monitoring and telephone messaging erased,
- pager station signal parameters in accordance with the POLPAGER system.
- counting times of counters - 30 seconds; counter values - 0,
- global times
 - entry delay - 60 seconds,
 - exit delay - 30 seconds,
 - keypad alarm duration - 60 seconds,

Communication identifiers (restore identifiers with FS109 function):

- control panel identifier |2|1|4|3|6|5|
- computer identifier |6|5|8|7|0|9|

Control panel access codes (restore codes with FS110 function):

- service code [1][2][3][4][5]
- master code partition 1 (A) [1][2][3][4]
- master code partition 2 (B) [2][3][4][5]
- master code partition 3 (C) [3][4][5][6]
- master code partition 4 (D) [4][5][6][7]

TECHNICAL DATA

Control panel

Input voltage, AC/AC power supply unit	AC 230(+10%; -15%)V
Main board supply voltage.....	AC 17...24V
Control panel DC power supply rated voltage	DC 13.6...13.8 V
DC power supply total current efficiency.....	2.2A
Battery charging current (changeover)	350/700mA
Battery cut-off voltage.....	9.5V ±0.3V
Recommended standby battery supply.....	12V/17Ah
Main board current consumption	70mA
Outputs OUT1 to OUT4 current-carrying capacity	2.2A
Outputs OUT5 & OUT6 current-carrying capacity	50mA
Output +KPD current-carrying capacity	1.5A
Spacing of mainboard mounting holes	162.6x91.5mm
Housing dimensions	305x305x85 mm

LED keypads

Supply voltage	11V...14V DC
Current consumption min/max.....	35/90mA
Dimensions: CA-10 KLED.....	145x78x27mm
CA-10 KLED-M.....	72x112x22mm
CA-10 KLED-S	80x95x21mm

LCD keypads

Supply voltage	11V...16V DC
Current consumption min/max.....	50/170mA
Dimensions: CA-10 KLCD.....	160x126x35 mm
CA-10 KLCD-L.....	145x114x29 mm
CA-10 KLCD-S	115x95x25 mm

Table 1. Example of panel power supply load estimation and battery selection.

No.	Loads	Max current	Mean current consumption
1	Main board CA-10	70mA	70mA
2	Keypads (2 LCD + 2 LED)	520mA	200mA
3	Outputs OUT1...OUT3	3 x 2.2A **	2A
4	Output OUT 4 (detectors 15 pcs.*)	15 x 20mA	15 x 20mA
5	Outputs OUT 5...OUT 6	2 x 50mA	50mA
6	Battery charging current	1000mA	-
Total max current consumption by the system with no alarm signaling		$\Sigma I = 70\text{mA} + 520\text{mA} + 300\text{mA} + 100\text{mA} + 1000\text{mA} = 1990\text{mA}$	
Battery selection based on max. and mean current consumption by the system, assumed duration of power trouble 12h, assumed 1 alarm with 15 min (0.25h) duration of signaling		$\Sigma A_{\text{Max}} = 1.25 \times (0,07 \times 12 + 0,52 \times 12 + 6,6 \times 0,25 + 0,3 \times 12 + 0,1 \times 12) = 1,25 \times 13,53 \approx 16,91\text{Ah}$ $\Sigma A_{\text{Av}} = 1.25 \times (0,07 \times 12 + 0,2 \times 12 + 4 \times 0,25 + 0,3 \times 12 + 0,05 \times 12) = 1,25 \times 8,44 \approx 10,55\text{Ah}$ <p>Recommended standby power supply: battery 12V /17Ah</p>	

* Assumed current consumption by a single detector 20mA.

** In case, where the capacity of the power supply is exceeded, the current is supplied by battery.



Notes:

- *The control panel power supply unit has been designed for work with lead batteries or other batteries with a similar charging curve (European Directives 91/157/EEC and 83/86/EEC).*
- *It is impermissible to connect a fully discharged battery (voltage on terminals without a load less than 11V) to the alarm panel. To avoid hardware damage, fully discharged or never used battery should be charged initially using proper charger.*

ATTENTION !

An efficient security system does not prevent burglary, assault or fire from happening, however it diminishes the risk that such a situation will cause no alarm or notification. Therefore, the SATEL Company recommends that operation of the whole security system be regularly tested.

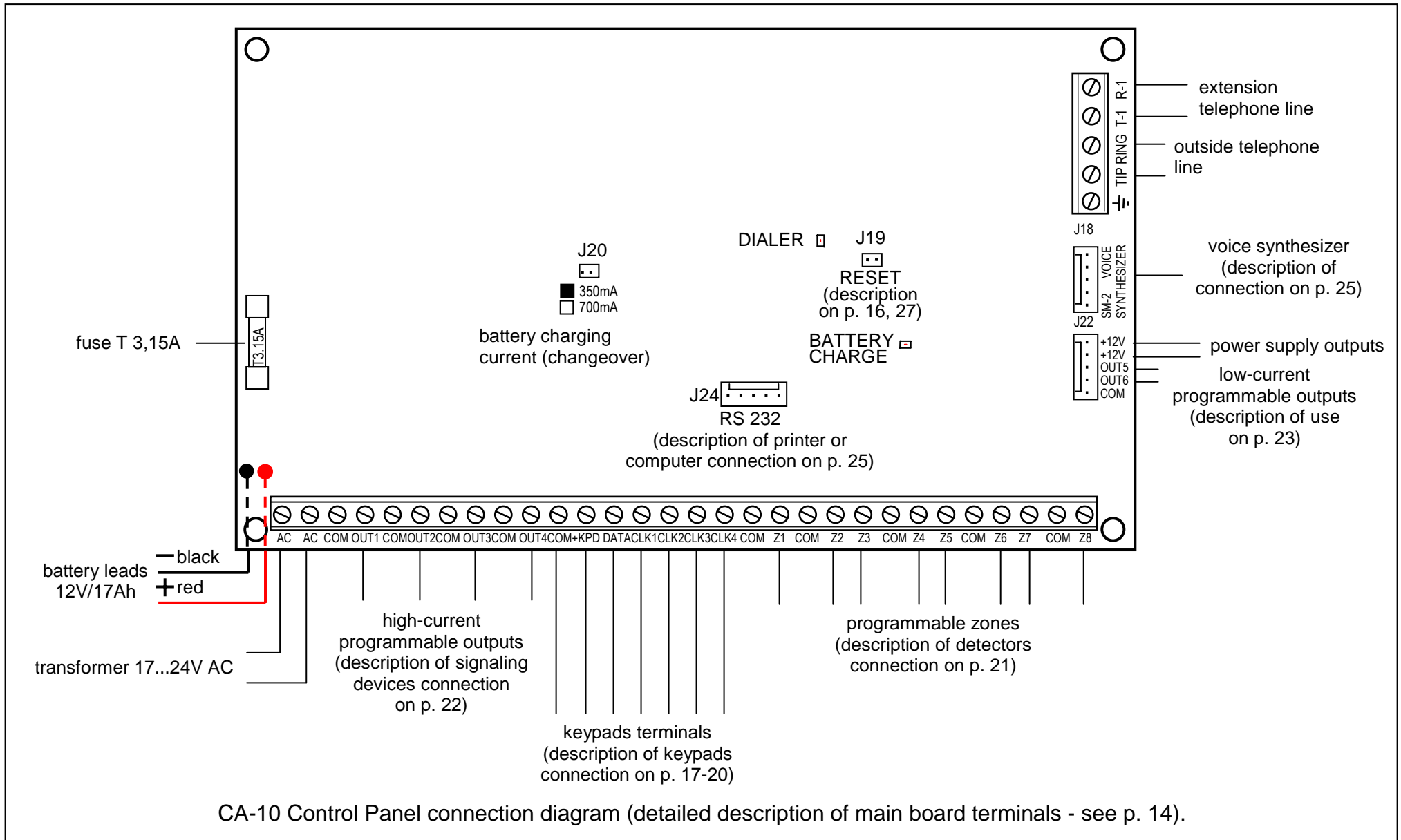

SATEL sp. z o.o.
ul. Schuberta 79
80-172 Gdańsk
POLAND
tel. + 48 58 320 94 00
info@satel.pl
www.satel.pl