

Off-Line Quasi-Resonant Switching Regulators

Features and Benefits

- Quasi-resonant topology IC \Rightarrow Low EMI noise and soft switching
- Bottom-skip mode \Rightarrow Improved system efficiency over the entire output load by avoiding increase of switching frequency
- Standby mode \Rightarrow Lowers input power at very light output load condition
- Avalanche-guaranteed MOSFET \Rightarrow Improves system-level reliability and does not require V_{DS} derating
- $650 V_{DSS} / 0.385 \Omega R_{DS(on)}$
- Various protections \Rightarrow Improved system-level reliability
 - Pulse-by-pulse drain overcurrent limiting
 - Overvoltage Protection (bias winding voltage sensing), with latch
 - Overload Protection with latch
 - Maximum on-time limit

Package: 7-Pin TO-3P



Not to scale

Description

The STR-X6759N is a quasi-resonant topology IC designed for SMPS applications. It shows lower EMI noise characteristics than conventional PWM solutions, especially at greater than 2 MHz. It also provides a soft-switching mode to turn on the internal MOSFET at close to zero voltage (V_{DS} bottom point) by use of the resonant characteristic of primary inductance and a resonant capacitor.

The package is a fully molded TO-3P, which contains the controller chip (MIC) and MOSFET, enabling output power up to 460 W at 230 VAC and 250 W at universal input. The bottom-skip mode skips the first bottom of V_{DS} and turns on the MOSFET at the second bottom point, to minimize an increase of operating frequency at light output load, improving system-level efficiency over the entire load range.

A standby mode is executed by clamping the secondary output. In general applications, standby mode reduces input power.

The soft-start mode minimizes surge voltage and reduces power stress to the MOSFET and to the secondary rectifying diodes during the start-up sequence.

Various protections such as overvoltage, overload, overcurrent, maximum on-time protections and avalanche-energy guaranteed MOSFET secure good system-level reliability.

Continued on the next page...

Typical Application

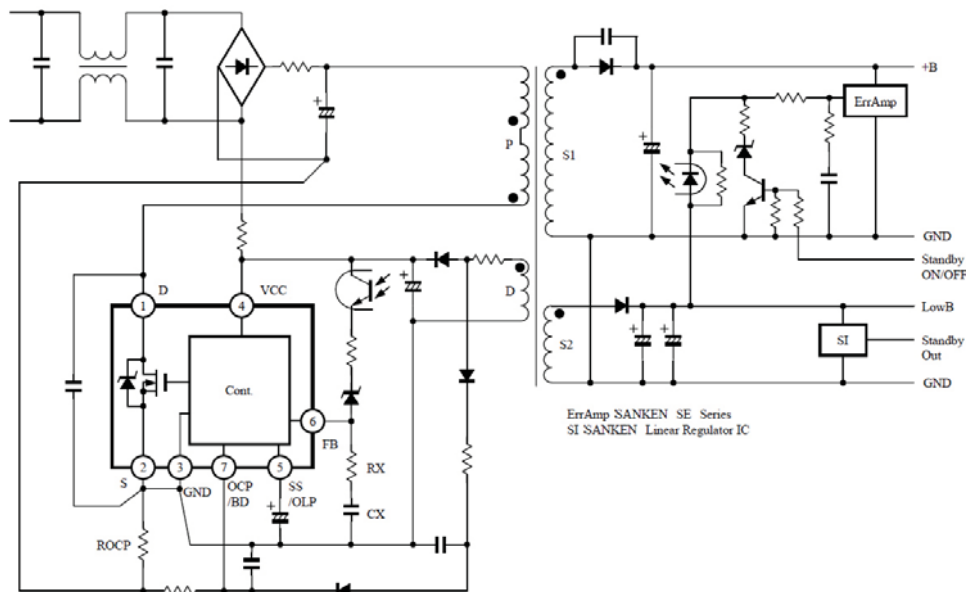

Description (continued)

Applications include the following:

- Set Top Box
- LCD PC monitor, LCD TV
- Printer, Scanner
- SMPS power supplies

Selection Guide

Part Number	Package
STR-X6759N	TO-3P

Absolute Maximum Ratings at $T_A = 25^\circ\text{C}$

Parameter	Symbol	Conditions	Rating	Unit
Drain Current ¹	I_{Dpeak}	Single pulse	22	A
Maximum Switching Current ²	I_{Dmax}	$T_A = -20^\circ\text{C}$ to 125°C	22	A
Single Pulse Avalanche Energy ³	E_{AS}	Single pulse, $V_{DD} = 30\text{ V}$, $L = 50\text{ mH}$, $I_{Lpeak} = 4.4\text{ A}$	500	mJ
Input Voltage for Controller (MIC)	V_{CC}		35	V
SS/OLP Terminal Voltage	V_{SSOLP}		-0.5 to 6.0	V
FB Terminal Inflow Current	I_{FB}		10	mA
FB Terminal Voltage	V_{FB}	I_{FB} within the limits of I_{FB}	-0.5 to 9.0	V
OCP/BD Terminal Voltage	V_{OCPBD}		-1.5 to 5.0	V
MOSFET Power Dissipation ⁴	P_{D1}	With infinite heatsink	46	W
		Without heatsink	2.8	W
Controller (MIC) Power Dissipation	P_{D2}	$V_{CC} \times I_{CC}$	0.8	W
Operating Internal Leadframe Temperature	T_F	Recommended operation temperature, see cautions	-20 to 125	$^\circ\text{C}$
Operating Ambient Temperature	T_{OP}		-20 to 125	$^\circ\text{C}$
Storage Temperature	T_{stg}		-40 to 125	$^\circ\text{C}$
Channel Temperature	T_{ch}		150	$^\circ\text{C}$

¹Refer to MOSFET ASO curve

² I_{DMAX} is the drain current determined by the drive voltage of the IC and the threshold voltage, V_{th} , of the MOSFET

³Refer to Avalanche Energy Derating curve

⁴Refer to MOSFET Ta-PD1 curve

All performance characteristics given are typical values for circuit or system baseline design only and are at the nominal operating voltage and an ambient temperature, T_A , of 25°C , unless otherwise stated.

Functional Block Diagram

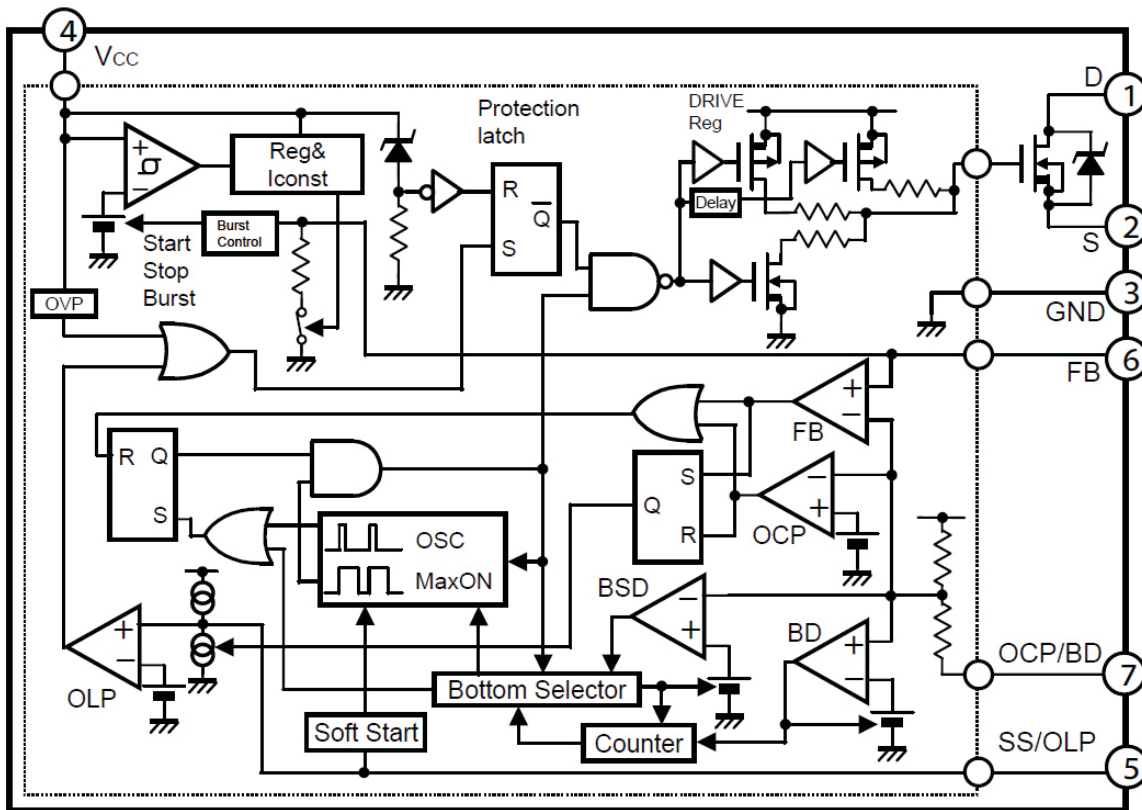

Terminal List Table

Number	Name	Description	Functions
1	D	Drain	MOSFET drain
2	S	Source	MOSFET source
3	GND	Ground terminal	Ground
4	VCC	Power supply terminal	Input of power supply for control circuit
5	SS/OLP	Soft Start/Overload Protection terminal	Input to set delay for Overload Protection and Soft Start operation
6	FB	Feedback terminal	Input for Constant Voltage Control and Burst (intermittent) Mode oscillation control signals
7	OCP/BD	Overcurrent Protection/Bottom Detection	Input for Overcurrent Detection and Bottom Detection signals

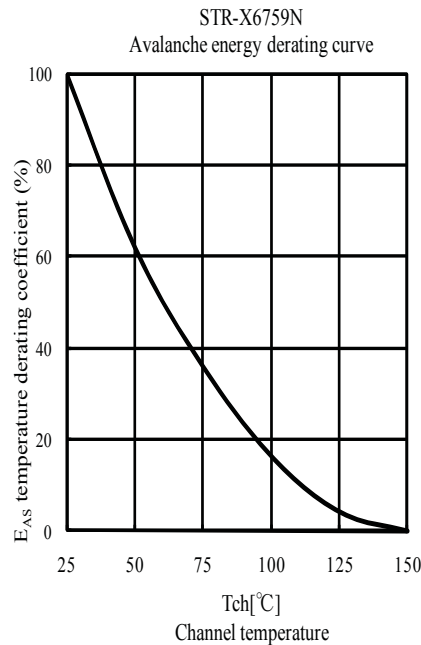
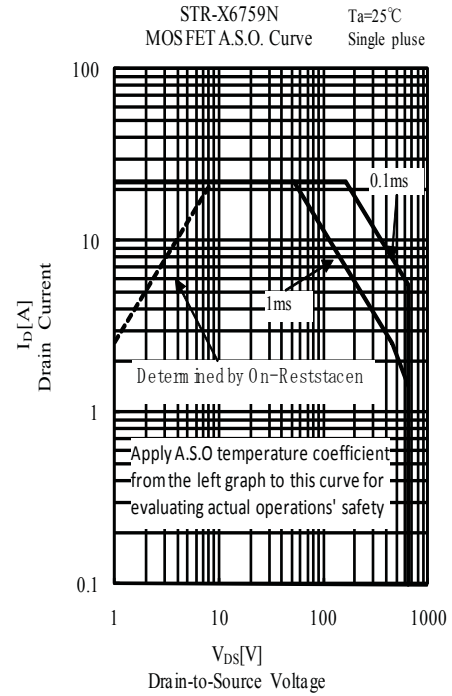
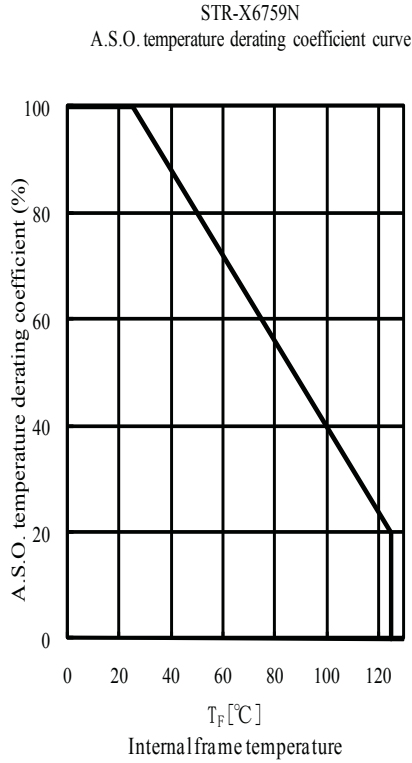

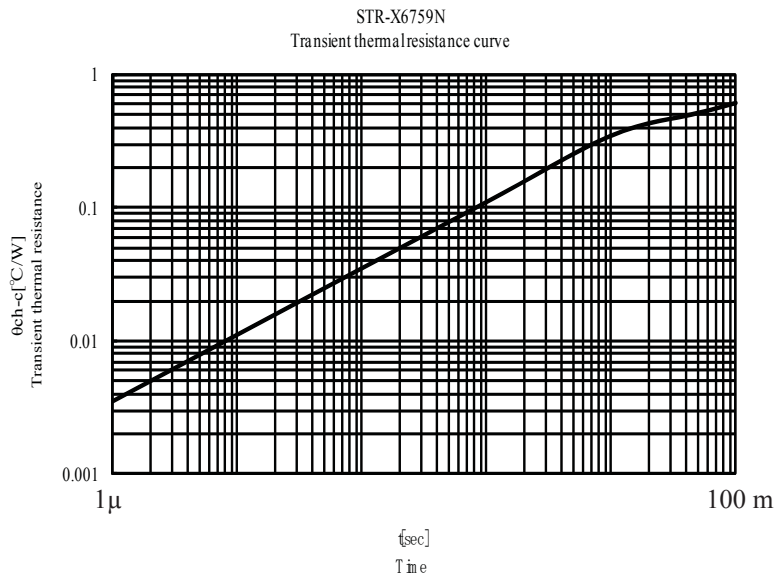
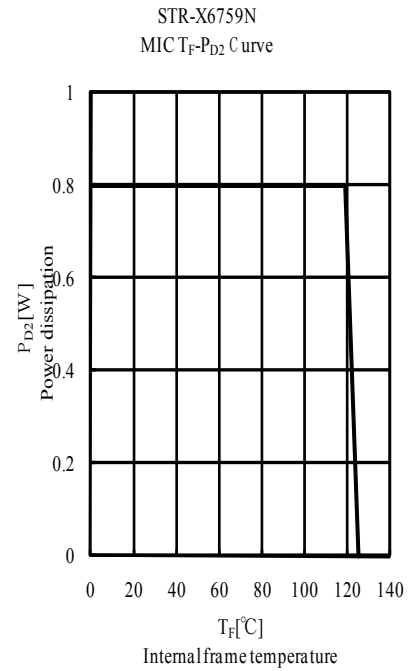
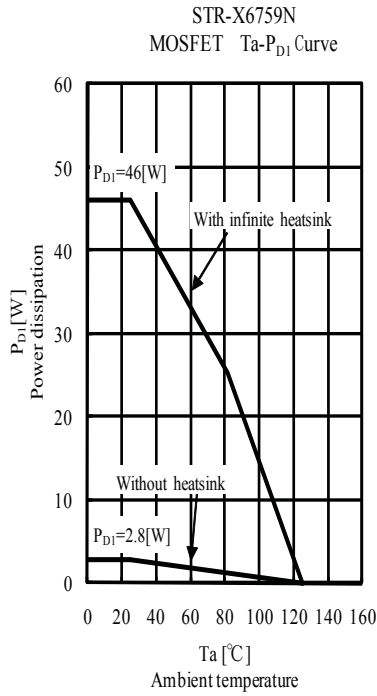

ELECTRICAL CHARACTERISTICS

Characteristic	Symbol	Test Conditions	Min.	Typ.	Max.	Units
ELECTRICAL CHARACTERISTICS for Controller (MIC)¹, valid at T_A = 25°C, V_{CC} = 20 V, unless otherwise specified						
Power Supply Start-up Operation						
Operation Start Voltage	V _{CC(ON)}	V _{CC} = 0→20 V	16.3	18.2	19.9	V
Operation Stop Voltage	V _{CC(OFF)}	V _{CC} = 20→8.8 V	8.8	9.7	10.6	V
Circuit Current In Operation	I _{CC(ON)}		–	–	6	mA
Circuit Current In Non-Operation	I _{CC(OFF)}	V _{CC} = 15 V	–	–	100	μA
Oscillation Frequency	f _{osc}		19	22	25	kHz
Soft Start Operation Stop Voltage	V _{SSOLP(SS)}	V _{SS/OLP} increasing	1.1	1.2	1.4	V
Soft Start Operation Charging Current	I _{SSOLP(SS)}	V _{SS/OLP} = 0 V	–710	–550	–390	μA
Normal Operation						
Bottom-Skip Operation Threshold Voltage 1	V _{OCPBD(BS1)}		–0.720	–0.665	–0.605	V
Bottom-Skip Operation Threshold Voltage 2	V _{OCPBD(BS2)}		–0.485	–0.435	–0.385	V
Overcurrent Detection Threshold Voltage	V _{OCPBD(LIM)}	V _{OCP/BD} falling	–0.995	–0.940	–0.895	V
OCP/BD Terminal Outflow Current	I _{OCPBD}	V _{OCP/BD} = –0.95 V	–250	–100	–40	μA
Quasi-Resonant Operation Threshold Voltage 1	V _{OCPBD(TH1)}	V _{OCP/BD} falling	0.28	0.40	0.52	V
Quasi-Resonant Operation Threshold Voltage 2	V _{OCPBD(TH2)}	V _{OCP/BD} rising	0.67	0.80	0.93	V
FB Terminal Threshold Voltage	V _{FB(OFF)}	V _{FB} rising	1.32	1.45	1.58	V
FB Terminal Inflow Current (Normal Operation)	I _{FB(ON)}	V _{FB} = 1.6 V	600	1000	1400	μA
Standby Operation						
Standby Operation Start Voltage	V _{CC(S)}	V _{CC} = 0→15 V, V _{FB} = 1.6 V	10.3	11.2	12.1	V
Standby Operation Start Voltage Interval	V _{CC(SK)}	V _{CC(SK)} = V _{CC(S)} – V _{CC(OFF)}	1.10	1.35	1.65	V
Standby Non-Operation Circuit Current	I _{CC(S)}	V _{CC} = 10.2 V, V _{FB} = 1.6 V	–	20	56	μA
FB Terminal Inflow Current, Standby Operation	I _{FB(S)}	V _{CC} = 10.2 V, V _{FB} = 1.6 V	–	4	14	μA
FB Terminal Threshold Voltage, Standby Operation	V _{FB(S)}	V _{CC} = 15 V, V _{FB} rising	0.55	1.10	1.50	V
Minimum On Time	t _{ON(MIN)}		0.65	1.05	1.45	μs
Protection Operation						
Maximum On Time	t _{ON(MAX)}		27.5	32.5	39.0	μs
Overload Protection Operation Threshold Voltage	V _{SSOLP(OLP)}		4.0	4.9	5.8	V
Overload Protection Operation Charging Current	I _{SSOLP(OLP)}	V _{SS/OLP} = 2.5 V	–16	–11	–6	μA
Overvoltage Protection Operation Voltage	V _{CC(OVP)}	V _{CC} = 0→30 V	25.5	27.7	29.9	V
Latch Circuit Holding Current ²	I _{CC(H)}	V _{CC(OFF)} – 0.3 V	–	45	140	μA
Latch Circuit Release Voltage ²	V _{CC(La.OFF)}	V _{CC} = 30→6 V, OVP operating	6.0	7.2	8.5	V
ELECTRICAL CHARACTERISTICS for MOSFET, valid at T_A = 25°C, unless otherwise specified						
Drain-to-Source Breakdown Voltage	V _{DSS}	I _{DSS} = 300 μA	650	–	–	V
Drain Leakage Current	I _{DSS}	V _{DSSS} = 650 V	–	–	300	μA
On Resistance	R _{DS(on)}	I _{DS} = 3.5 A	–	–	0.385	Ω
Switching Time	t _f		–	–	600	ns
Thermal Resistance	R _{θch-F}	Channel to internal frame	–	–	0.99	°C/W

¹Current polarity with respect to the IC: positive current indicates current sink at the terminal named, negative current indicates source at the terminal named.

²The latch circuit means a circuit operated OVP and OLP.

Packing Specifications

100 pieces per tray
5 trays per inner carton
(Outer packing dependent on quantity)

Dimensions in millimeters

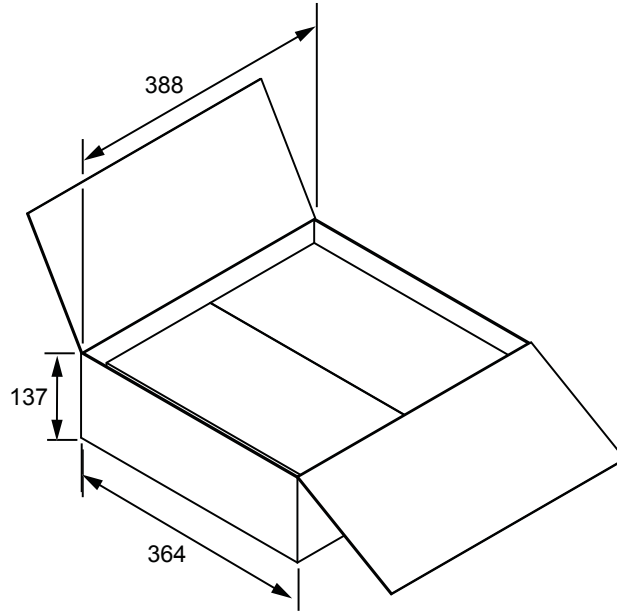
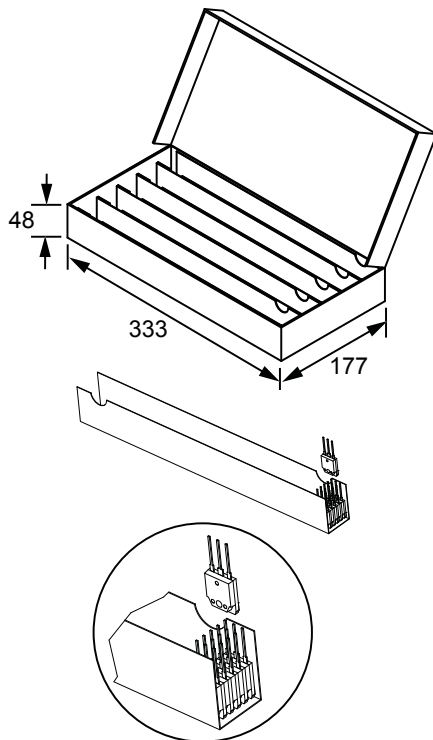

4 inner cartons per outer carton
500 pieces maximum per inner carton
2000 pieces maximum per outer carton

Dimensions in millimeters

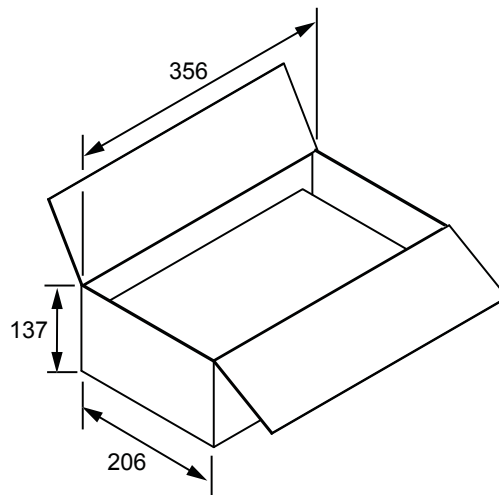

2 inner cartons per outer carton
500 pieces maximum per inner carton
1000 pieces maximum per outer carton

Dimensions in millimeters

Package Outline Drawing, TO-3P

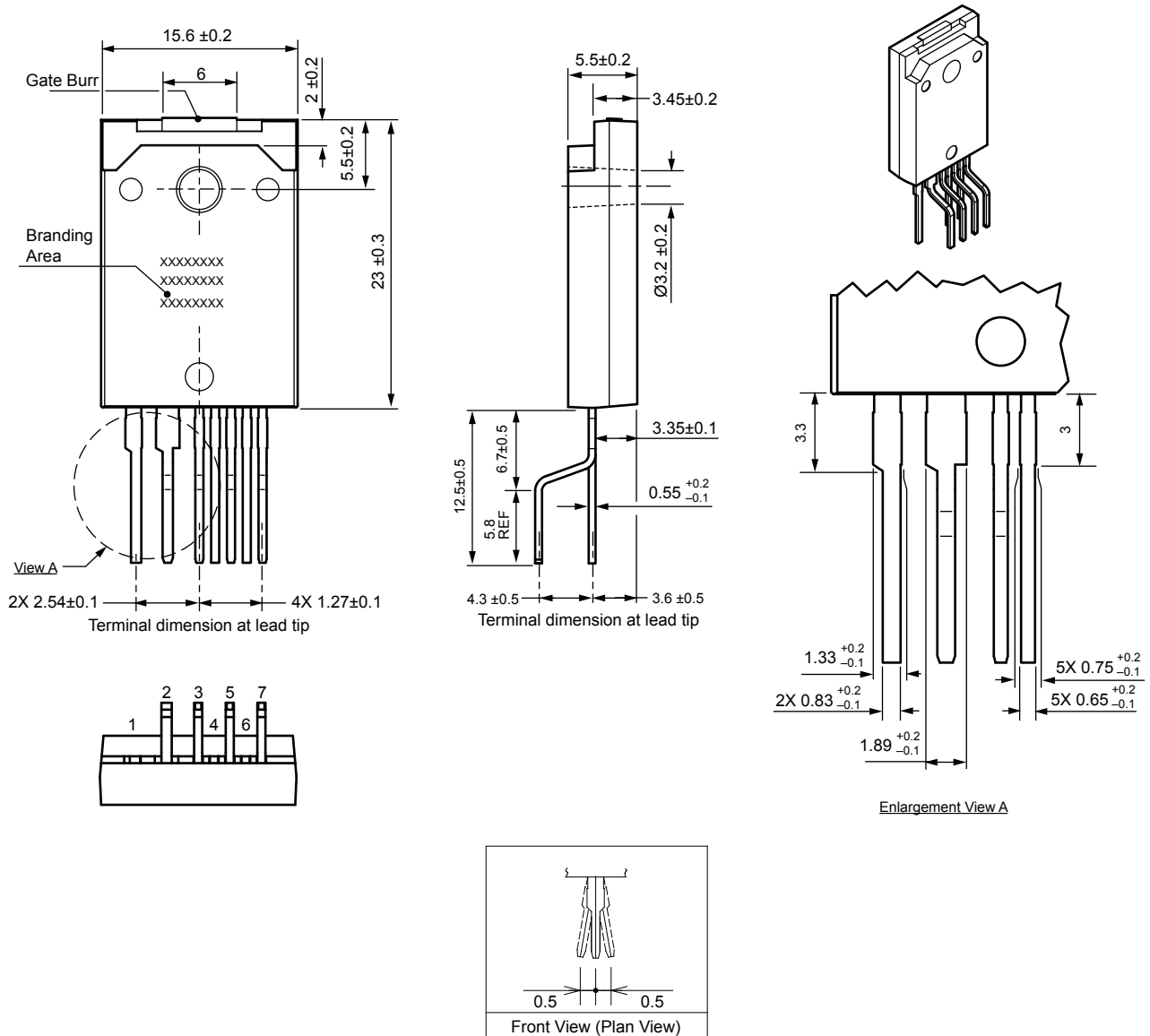

Gate burr: 0.3 mm (max.)
 Terminal core material: Cu
 Terminal treatment: Ni plating and Pb-free solder dip
 Leadform: 1905

Approximate weight: 6 g

Dimensions in millimeters

Drawing for reference only

Branding codes (exact appearance at manufacturer discretion):

1st line, type: STR
 2nd line, subtype: X6759
 3rd line, lot: YM DD N

Where: Y is the last digit of the year of manufacture
 M is the month (1 to 9, O, N, D)
 DD is the 2-digit date
 N is the suffix of the subtype



Leadframe plating Pb-free. Device composition includes high-temperature solder (Pb >85%), which is exempted from the RoHS directive.

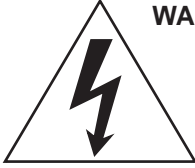

WARNING — These devices are designed to be operated at lethal voltages and energy levels. Circuit designs that embody these components must conform with applicable safety requirements. Precautions must be taken to prevent accidental contact with power-line potentials.

The use of an isolation transformer is recommended during circuit development and breadboarding.

Because reliability can be affected adversely by improper storage environments and handling methods, please observe the following cautions.

Cautions for Storage

- Ensure that storage conditions comply with the standard temperature (5°C to 35°C) and the standard relative humidity (around 40 to 75%); avoid storage locations that experience extreme changes in temperature or humidity.
- Avoid locations where dust or harmful gases are present and avoid direct sunlight.
- Reinspect for rust on leads and solderability of products that have been stored for a long time.

Cautions for Testing and Handling

When tests are carried out during inspection testing and other standard test periods, protect the products from power surges from the testing device, shorts between adjacent products, and shorts to the heatsink.

Remarks About Using Silicone Grease with a Heatsink

- When silicone grease is used in mounting this product on a heatsink, it shall be applied evenly and thinly. If more silicone grease than required is applied, it may produce stress.
- Coat the back surface of the product and both surfaces of the insulating plate to improve heat transfer between the product and the heatsink.
- Volatile-type silicone greases may permeate the product and produce cracks after long periods of time, resulting in reduced heat radiation effect, and possibly shortening the lifetime of the product.
- Our recommended silicone greases for heat radiation purposes, which will not cause any adverse effect on the product life, are indicated below:

Type	Suppliers
G746	Shin-Etsu Chemical Co., Ltd.
YG6260	Momentive Performance Materials
SC102	Dow Corning Toray Silicone Co., Ltd.

Recommended operation temperature

- Inner frame temperature in operation $T_F = 115^\circ\text{C}$

Heatsink Mounting Method

- **Torque When Tightening Mounting Screws.** Thermal resistance increases when tightening torque is low, and radiation effects are decreased. When the torque is too high, the screw can strip, the heatsink can be deformed, and distortion can arise in the product frame. To avoid these problems, observe the recommended tightening torques for this product package type, TO-3P: 0.588 to 0.785 N•m (6 to 8 kgf•cm).
- For effective heat transfer, the contact area between the product and the heatsink should be free from burrs and metal fragments, and the heatsink should be flat and large enough to contact over the entire side of the product, including mounting flange and exposed thermal pad, and have a minimal mounting hole to prevent possible deflection and cracking of the product case when fastened to the heatsink.

Soldering

- When soldering the products, please be sure to minimize the working time, within the following limits:
260±5°C 10 s
350±5°C 3 s
- Soldering iron should be at a distance of at least 1.5 mm from the body of the products

Electrostatic Discharge

- When handling the products, operator must be grounded. Grounded wrist straps worn should have at least 1 MΩ of resistance to ground to prevent shock hazard.
- Workbenches where the products are handled should be grounded and be provided with conductive table and floor mats.
- When using measuring equipment such as a curve tracer, the equipment should be grounded.
- When soldering the products, the head of soldering irons or the solder bath must be grounded in order to prevent leak voltages generated by them from being applied to the products.
- The products should always be stored and transported in our shipping containers or conductive containers, or be wrapped in aluminum foil.

The products described herein are manufactured in Japan by Sanken Electric Co., Ltd. for sale by Allegro MicroSystems, Inc.

Sanken and Allegro reserve the right to make, from time to time, such departures from the detail specifications as may be required to permit improvements in the performance, reliability, or manufacturability of its products. Therefore, the user is cautioned to verify that the information in this publication is current before placing any order.

When using the products described herein, the applicability and suitability of such products for the intended purpose shall be reviewed at the users responsibility.

Although Sanken undertakes to enhance the quality and reliability of its products, the occurrence of failure and defect of semiconductor products at a certain rate is inevitable.

Users of Sanken products are requested to take, at their own risk, preventative measures including safety design of the equipment or systems against any possible injury, death, fires or damages to society due to device failure or malfunction.

Sanken products listed in this publication are designed and intended for use as components in general-purpose electronic equipment or apparatus (home appliances, office equipment, telecommunication equipment, measuring equipment, etc.). Their use in any application requiring radiation hardness assurance (e.g., aerospace equipment) is not supported.

When considering the use of Sanken products in applications where higher reliability is required (transportation equipment and its control systems or equipment, fire- or burglar-alarm systems, various safety devices, etc.), contact a company sales representative to discuss and obtain written confirmation of your specifications.

The use of Sanken products without the written consent of Sanken in applications where extremely high reliability is required (aerospace equipment, nuclear power-control stations, life-support systems, etc.) is strictly prohibited.

The information included herein is believed to be accurate and reliable. Application and operation examples described in this publication are given for reference only and Sanken and Allegro assume no responsibility for any infringement of industrial property rights, intellectual property rights, or any other rights of Sanken or Allegro or any third party that may result from its use. The contents in this document must not be transcribed or copied without Sanken's or Allegro's written consent.

Copyright ©2009 Allegro MicroSystems, Inc.

This datasheet is based on Sanken datasheet SSE-23859



Allegro MicroSystems, Inc.
115 Northeast Cutoff
Worcester, Massachusetts 01615-0036 U.S.A.
1.508.853.5000; www.allegromicro.com



Worldwide ContactsAsia-Pacific**China****Sanken Electric Hong Kong Co., Ltd.**

Suite 1026, Ocean Centre, Canton Road
Tsimshatsui, Kowloon, Hong Kong
Tel: 852-2735-5262, Fax: 852-2735-5494

Sanken Electric (Shanghai) Co., Ltd.

Room 3202, Maxdo Centre, Xingyi Road 8
Changning District, Shanghai, China
Tel: 86-21-5208-1177, Fax: 86-21-5208-1757

Taiwan Sanken Electric Co., Ltd.

Room 1801, 18th Floor, 88 Jung Shiau East Road
Sec. 2, Taipei 100, Taiwan R.O.C.
Tel: 886-2-2356-8161, Fax: 886-2-2356-8261

Japan**Sanken Electric Co., Ltd.
Overseas Sales Headquarters**

Metropolitan Plaza Building, 1-11-1 Nishi-Ikebukuro
Toshima-ku, Tokyo 171-0021, Japan
Tel: 81-3-3986-6164, Fax: 81-3-3986-8637

Korea**Sanken Electric Korea Co., Ltd.**

Mirae Asset Life Building, 6F
168 Kongduk-dong, Mapo-ku
Seoul 121-705, Korea
Tel: 82-2-714-3700, Fax: 82-2-3272-2145

Singapore**Sanken Electric Singapore Pte. Ltd.**

150 Beach Road, #14-03 The Gateway West
Singapore 189720
Tel: 65-6291-4755, Fax: 65-6297-1744

Europe**Sanken Power Systems (UK) Limited**

Pencoed Technology Park
Pencoed, Bridgend CF35 5HY, United Kingdom
Tel: 44-1656-869-100, Fax: 44-1656-869-162

North America**United States****Allegro MicroSystems, Inc.**

115 Northeast Cutoff
Worcester, Massachusetts 01606, U.S.A.
Tel: 1-508-853-5000, Fax: 1-508-853-7895

Allegro MicroSystems, Inc.

14 Hughes Street, Suite B105
Irvine, California 92618, U.S.A.
Tel: 1-949-460-2003, Fax: 1-949-460-7837