

AT 2005B

PIN CONFIGURATION

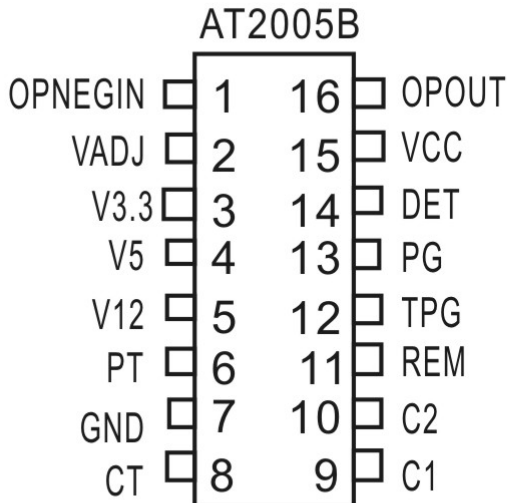

PIN DESCRIPTION

Pin No.	Pin Name	TYPE	FUNCTION
1	OPNEGIN	I	OP COMPENSATION NEGATIVE INPUT
2	VADJ	I	VOLTAGE ADJUST
3	V3.3	I	OVP/UVI INPUT FOR 3.3V
4	V5	I	OVP/UVI INPUT FOR 5V
5	V12	I	OVP/UVI INPUT FOR 12V
6	PT	I	EXTRA OVP INPUT PROTECTION
7	GND	P	GROUND
8	CT	-	OSCILLATION FREQUENCY BY SETTING CAP
9	C1	O	OUTPUT1
10	C2	O	OUTPUT2
11	REM	I	REMOTE ON/OFF INPUT,IF REM="LOW" THAT MEANS THE MAIN SMPS IS OPERATION,WHEN REM="HIGH",THE MAIN SMPS IS TURNED-OFF.
12	TPG	-	POWER GOOD DELAY TIME
13	PG	O	POWER GOOD SIGNAL IF PG="HIGH" MEANS "POWER GOOD" AND PG="LOW" MEANS "POWERFAIL"
14	DET	I	POWER GOOD SIGNAL INPUT
15	VCC	P	SUPPLY VOLTAGE
16	OPOUT	O	OP COMPENSATION OUTPUT

BLOCK DIAGRAM

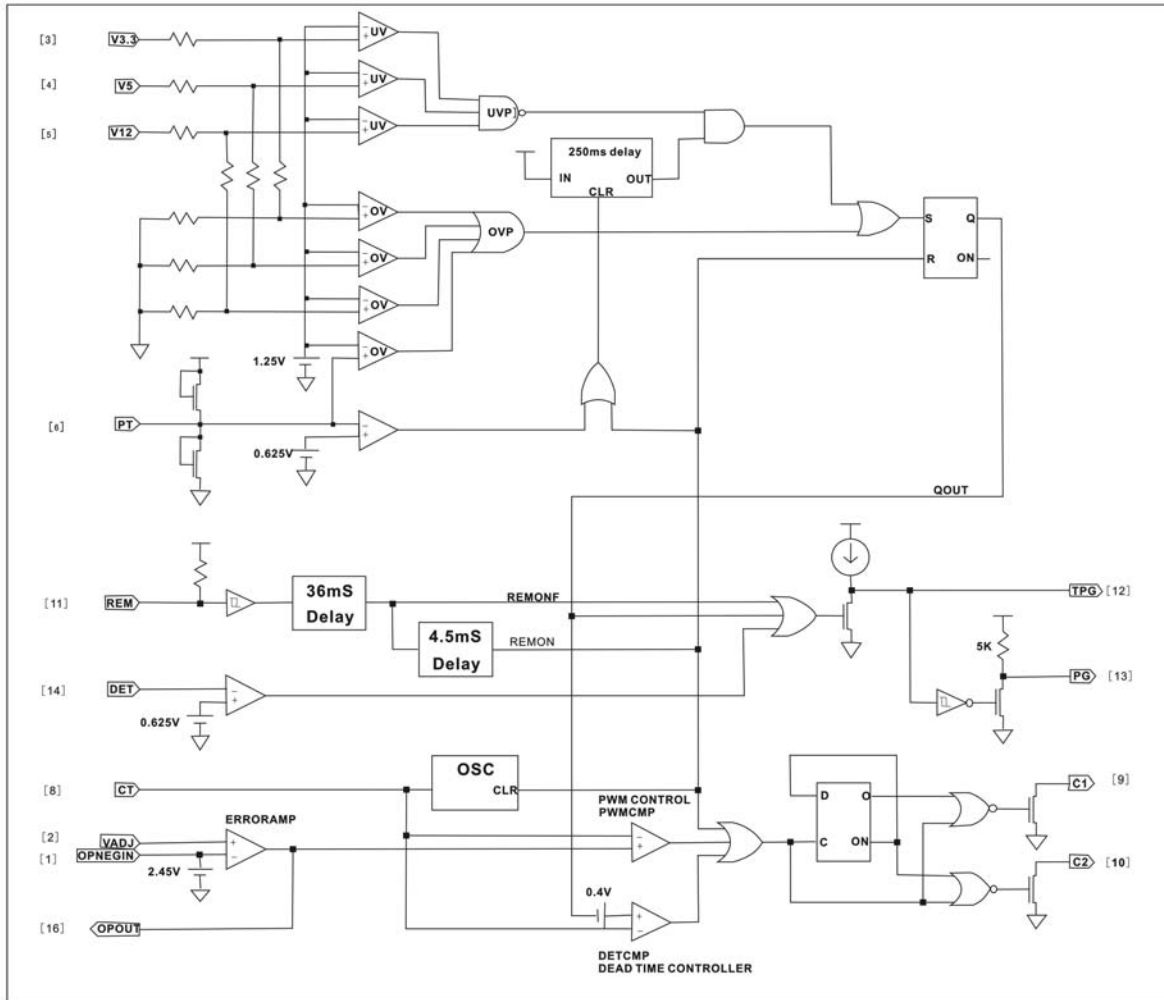

ABSOLUTE MAXIMUM RATINGS, VCC=5.5V

CHARACTERISTICS	SYMBOL	VALUE	Unit
Supply voltage	VCC	5.5	V
Drain output voltage	Vcc1, Vcc2	5.5	V
Drain output current	Icc1, Icc2	200	mA
Power dissipation	Pd	200	mW
Operating temperature	Topr	-10 ~ +70	°C
Storage temperature	Tstg	-65 ~ +150	°C

TEMPERATURE CHARACTERISTICS, VCC=5V

CHARACTERISTICS	SYMBOL	Min.	Typ.	Max.	Unit
Coefficient of Vref (-10°C ~ +85°C)			0.01		%/°C



AT 2005B

ELECTRICAL CHARACTERISTICS, TA=25°C, V_{CC}=5V,

CHARACTERISTICS	SYMBOL	TEST CONDITION	Min.	Typ.	Max.	Unit
-----------------	--------	----------------	------	------	------	------

DEAD TIME CONTROL SECTION

INPUT THRESHOLD VOLTAGE	V _{thdt}	ZERO DUTY CYCLE		3.0	3.3	V
		MAX. DUTY CYCLE		0.1		

ERROR AMP SECTION

CLOSE LOOP VOLTAGE GAIN		0.5V ~ 3.5V		65		dB
CROSS OVER POINT		0dB		320		KHZ
OPNEG BIAS VOLTAGE		OPNEG OPEN	2.38	2.45	2.52	V

OUTPUT SECTION

OUTPUT SATURATION VOLTAGE	V _{dssat}	I _d =200mA		1.1	1.3	V
DRAIN OFF-STATE CURRENT	I _{doff}	V _{cc} =V _d =V _s =0V		2	10	uA
RISING TIME	T _r			100	200	ns
FALLING TIME	T _f			50	200	ns

PROTECTION SECTION

OVER VOLTAGE PROTECTION (OVP)	V33		3.8	4.1	4.3	V
	V5		5.8	6.2	6.6	V
	V12		4.41	4.64	4.90	V
	PT		1.2	1.25	1.3	V
UNDER VOLTAGE PROTECTION (UVP)	V33		1.78	1.98	2.18	V
	V5		2.70	3.00	3.30	V
	V12		2.11	2.37	2.63	V
UVP DISABLE VOLTAGE	PT		0.55	0.62	0.68	V
UVP DELAY TIME	T _{d.uvp}		100	250	500	ms

REMOTE ON/OFF SECTION

REM HIGH INPUT VOLTAGE	V _{remh}		2.0			V
REM LOW INPUT VOLTAGE	V _{reml}				0.8	V
REM PULL HIGH VOLTAGE	V _{remo}		2.0		5.25	V
REM DELAY TIME	T _{rem}		30	36	42	ms
REM OFF DELAY TIME	T _{off}		3.5	4.5	5.5	ms

POWER GOOD SECTION

DETECTING INPUT VOLTAGE	V _{det}		0.55	0.62	0.68	V
PG OUTPUT PULL-UP RESISTOR	R _{pup, pg}			5		KΩ
PG OUTPUT LOAD RESISTOR	R _{pg}		0.5	1	2	KΩ
CHARGING CURRENT FOR TPG	I _{chg.tpg}			30		uA
PG DELAY TIME	T _{d.pg}	C=2.2uF	100	250	500	ms
OUTPUT SATURATION VOLTAGE	V _{sat.pg}	I _{pg} =10mA		0.2	0.4	V

TOTAL DEVICE

STANDBY SUPPLY CURRENT	I _{cc}			10	20	mA
------------------------	-----------------	--	--	----	----	----

OSCILLATION SECTION

OSCILLATION FREQUENCY	F _{osc}	CT=2200P	50		60	KHZ
FREQ. CHANGE WITH TEMP.	F _{osc/T}	CT=2200p		2		%



APPLICATION NOTE

1. Input impedance:

Pin No.	Pin Name	Input impedance
3	V33	39KΩ
4	V5	61KΩ
5	V12	39KΩ
6	PT	279KΩ (VGS1=4.12V) 59.8KΩ (VGS2=0.88V) (VCC=5V, PT=0.88V)

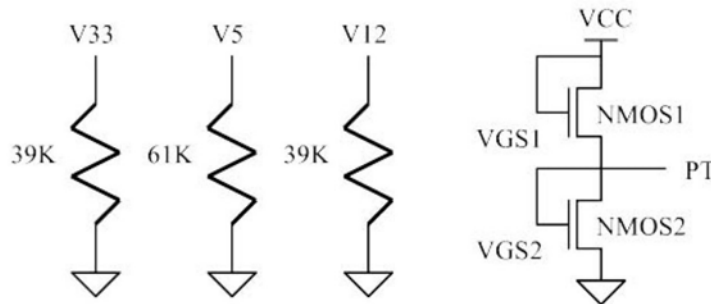

2. Operation Frequency:

The period of the sawtooth is T_{OSC} :

$$I_{CHARGE} = (1.25V / 6.1 K\Omega) * 2 = 410\mu A$$

$$T_{OSC} = (3.3V * C_T) / I_{CHARGE} = (3.3V * 2200pF) / 410\mu A$$

$$F_{OSC} = 1 / T_{OSC} = 56.5 KHZ$$

For Push-Pull applications:

$$F_{PUSH-PULL} = 1 / 2 T_{OSC}$$

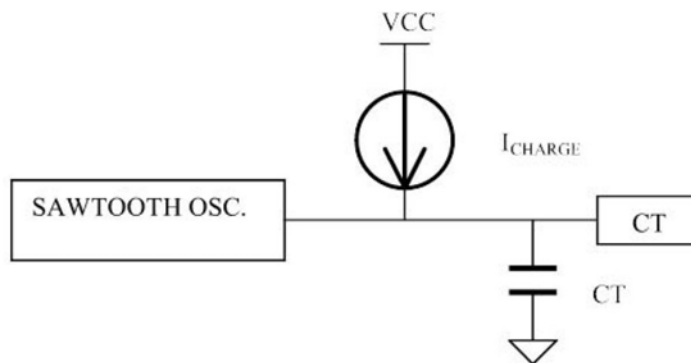

AT 2005B

3. REMOTE ON/OFF :

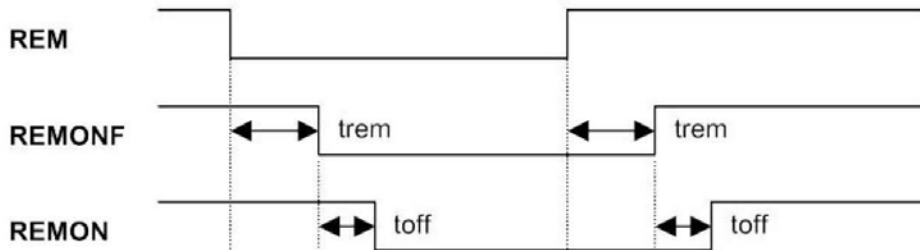

4. Under Voltage Protection Delay Time :

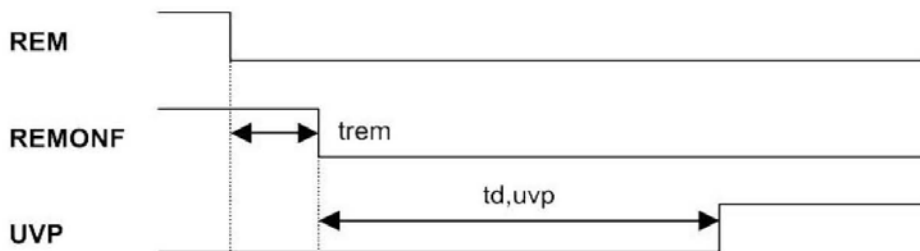

5. Pulse Width Modulation Block :

The output pulse width modulation is generated by comparison of the saw-tooth waveform from the capacitor C_T to the feedback of the voltage.

Therefore, an increase in feedback control signal amplitude cause a linear decrease of the output pulse width. The timing diagram is shown as below:

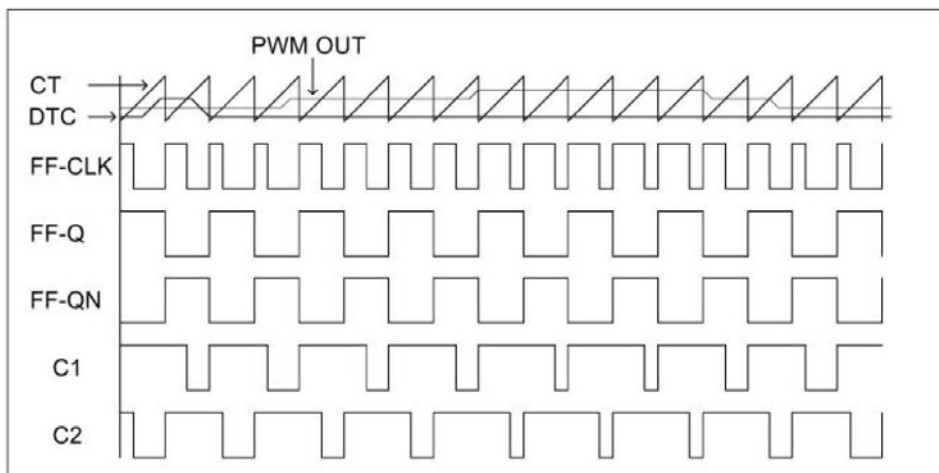

AT 2005B

6. Protection Control of the Soft-Start:

The soft-start function is to reduce the large current surge during power-up & prevent the output voltages (V33/V5/V12) reach the Over Voltage Protection level . The circuit is shown in reference application circuit .

7. The function of “PT”: (Default floating $V_{PT} = 0.8V$)

This signal is prepared for extra Over Voltage Protection Input ($V_{PT} > 1.25V$) or another Disable Under Voltage Protection function ($V_{PT} < 0.62V$)

8. Reference Application Circuit:

