

Standard H-Bridge Module

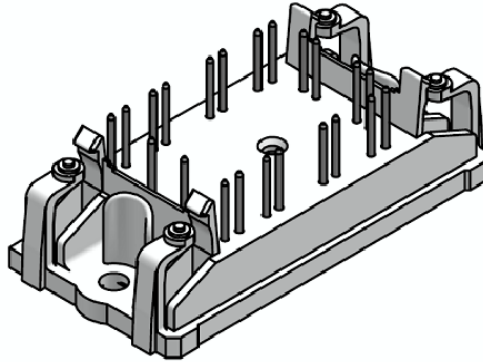

*fast*PACK 0 H 2nd gen

Features

- H-bridge 600V..1200V / 20A..100A
- Standard- and high speed IGBT's or MOS-FET
- Ultra low inductive design
- Tyco Electronics - Power Flow Through for simple PCB routing
- Tyco Electronics - Clip In, the reliable interconnection between PCB, module and heatsink
- Temperature Sensor
- Easy paralleling to ½ bridge
- Optional capacitors

Module Types

part – number V23990-	Voltage	Current
MOS-FET		
P622-F64-PM	600V	30A
P622-F74-PM high performance	600V	30A
high speed IGBT		
P623-F04-PM	600 V	60A
P623-F14-PM high performance	600 V	60A
Trench Fieldstop IGBT		
P623-F24-PM	600V	50A
P624-F24-PM	600V	75A
P625-F24-PM	600V	100A
Phantom Speed IGBT		
P629-F44-PM	1200V	25A
P629-F46-PM hyper fast FRED	1200V	25A
P629-F54-PM high performance	1200V	25A
P629-F56-PM high performance + hyper fast FRED	1200V	25A
with capacitor:		
MOS-FET		
P722-F64-PM	600V	30A
P722-F74-PM high performance	600V	30A
high speed IGBT		
P723-F04-PM	600 V	60A
P723-F14-PM high performance	600 V	60A
Phantom Speed IGBT		
P729-F44-PM	1200V	25A
P729-F46-PM hyper fast FRED	1200V	25A
P729-F54-PM high performance	1200V	25A
P729-F56-PM high performance + hyper fast FRED	1200V	25A

Schematics

P622 modules:

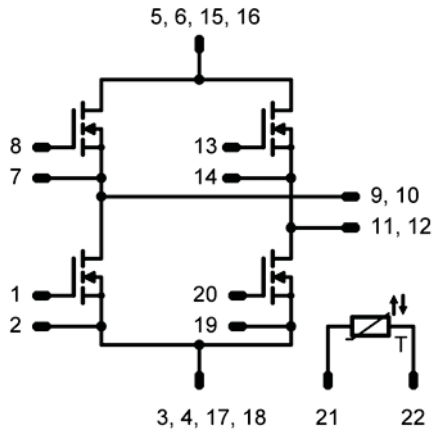

P623, P624, P625, P629 modules:

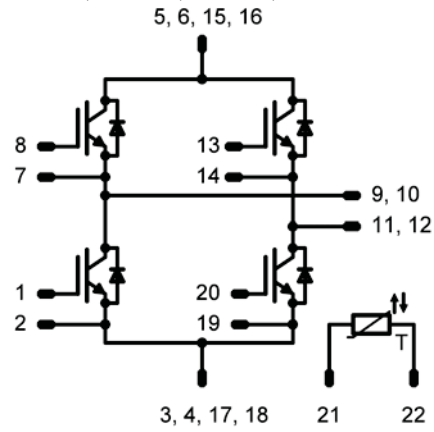

P722 modules:

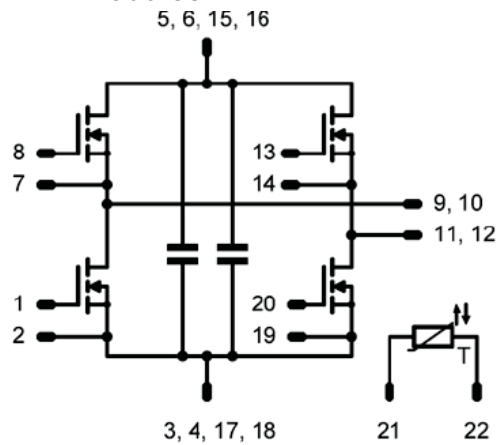

P723, P729 modules:

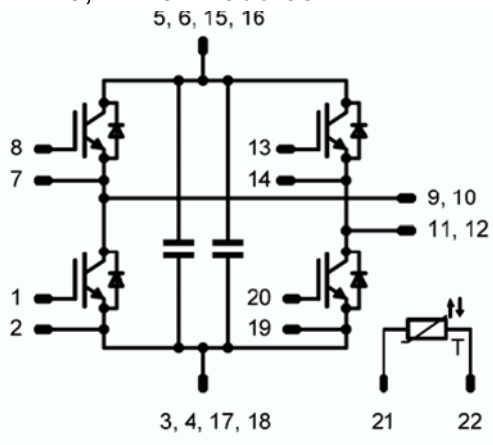

Outline / Pinout

Pin Table		
Pin	X	Y
1	0	22,5
2	2,9	22,5
3	8,3	22,5
4	10,8	22,5
5	19,6	22,5
6	22,1	22,5
7	29,1	22,5
8	32	22,5
9	33,5	17,8
10	33,5	15,3
11	33,5	7,2
12	33,5	4,7
13	32	0
14	29,1	0
15	22,1	0
16	19,6	0
17	10,8	0
18	8,3	0
19	2,9	0
20	0	0
21	0	8
22	0	14,5

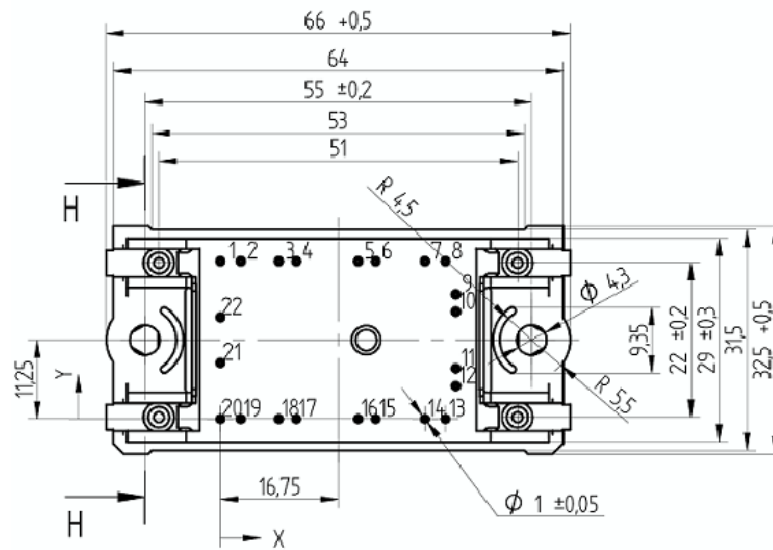

Tolerance of pin positions: 0.5 mm at pinhead

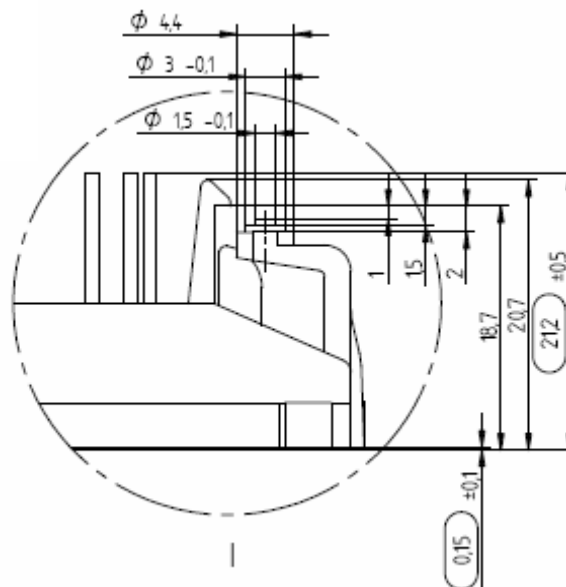

Handling Instructions

PCB

- The module must be fixed to the PCB by clipping into the adequate holes before pin soldering. For further details see PCB holes and Mounting in document V23990-P-M111-*-31.
- After fixing all pins must be soldered into the PCB. For an appropriate solderprofile for module pins soldering see document, Typical heat profile for wave soldering on page 4 of V23990-P-M111-*-31.
- During assembly, at a max. module temperature of 25°C, the pins should not be drawn or pushed over ± 0.2 mm or loaded with higher force than 35N.
- At a maximum substrate-temperature of 100°C the load of the pin should not exceed ± 5 N.
- Vibration stress on pin is not allowed

heatsink

- the heatsink surface must be clean and particleless.
- the flatness must be < 0.05 mm for 100 mm continuous.
- the surface roughness should be less than: RZ 0.01mm.

thermal conduction material:

- OPTION 1: thermal paste Homogeneous applying of the thermal conductive paste over the whole module bottom with a thickness of max. 0.05 mm.

- OPTION 2: thermal foil

A thermal foil with a aluminium core layer and two outer layer made of phase change material should be used. The total thickness of the foil has to be less then 0,08mm / 0,003 inch. Thicker foils could cause braking of the ceramic substrate and will increase the thermal resistance.

Recommended foil type: *Kunze Folien KU-ALC5 or ALF5*

Recommended foil dimensions:

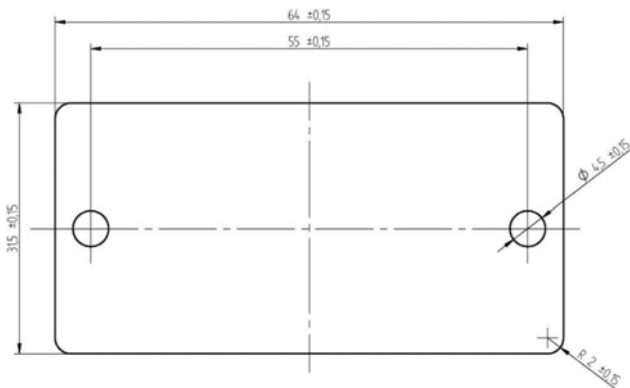

fastening screws to the heatsink if plain washer is used:

- Tighten both screws with the half torque first.
- Tighten both screws with max. torque second (if it is possible, tighten after 3 hours again).
Flat washer DIN 125 or DIN 433, Screw M4 DIN 7985.

fastening screws to the heatsink if plain washer is used together with a spring lock washer (recommended mounting):

- Tighten both screws with max. torque.
Flat washer DIN 125 or DIN 433, Spring washer DIN127 or DIN 128, Screw M4 DIN 7985.

Torque instructions for the heatsink:

- Mounting torque $M_a = 2.0-2.2$ Nm

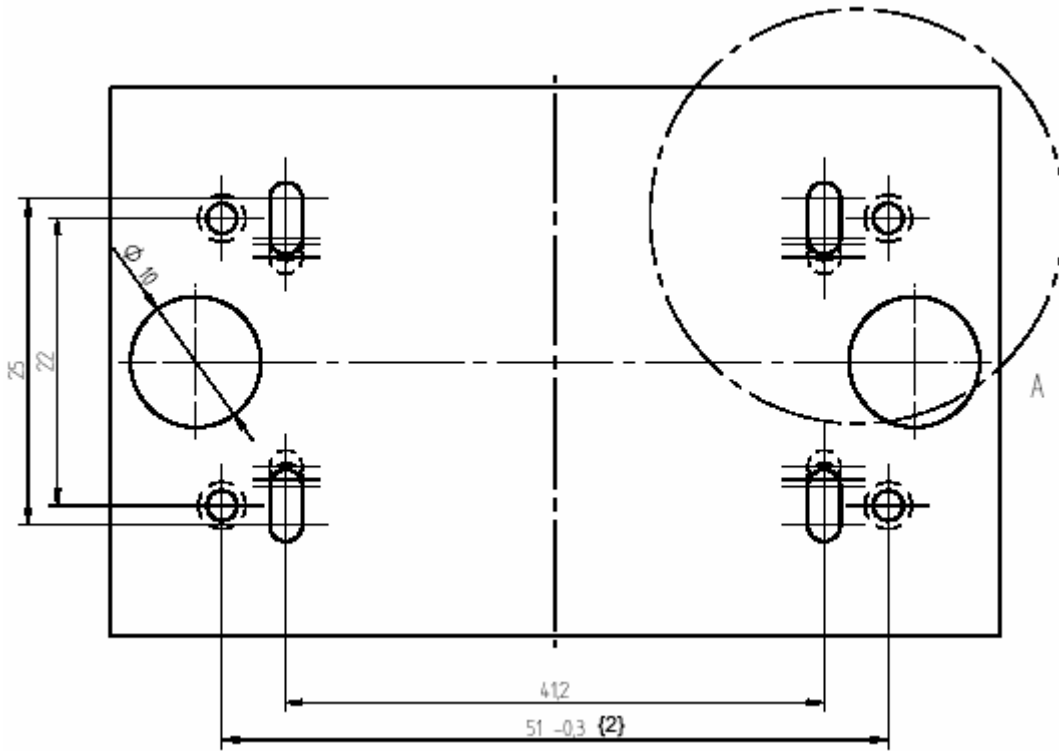
PCB holes

PCB thickness	d1	l1
1,5 mm	without holes	3 mm
2 mm	2,3 mm	3,5 mm
2,5 mm	3,6 mm	4,5 mm

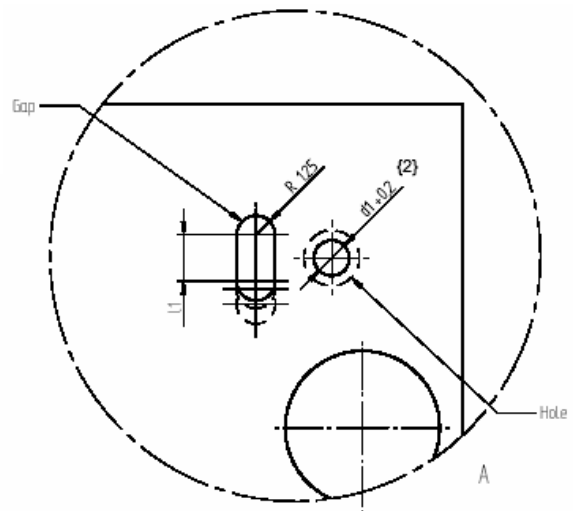

Mounting

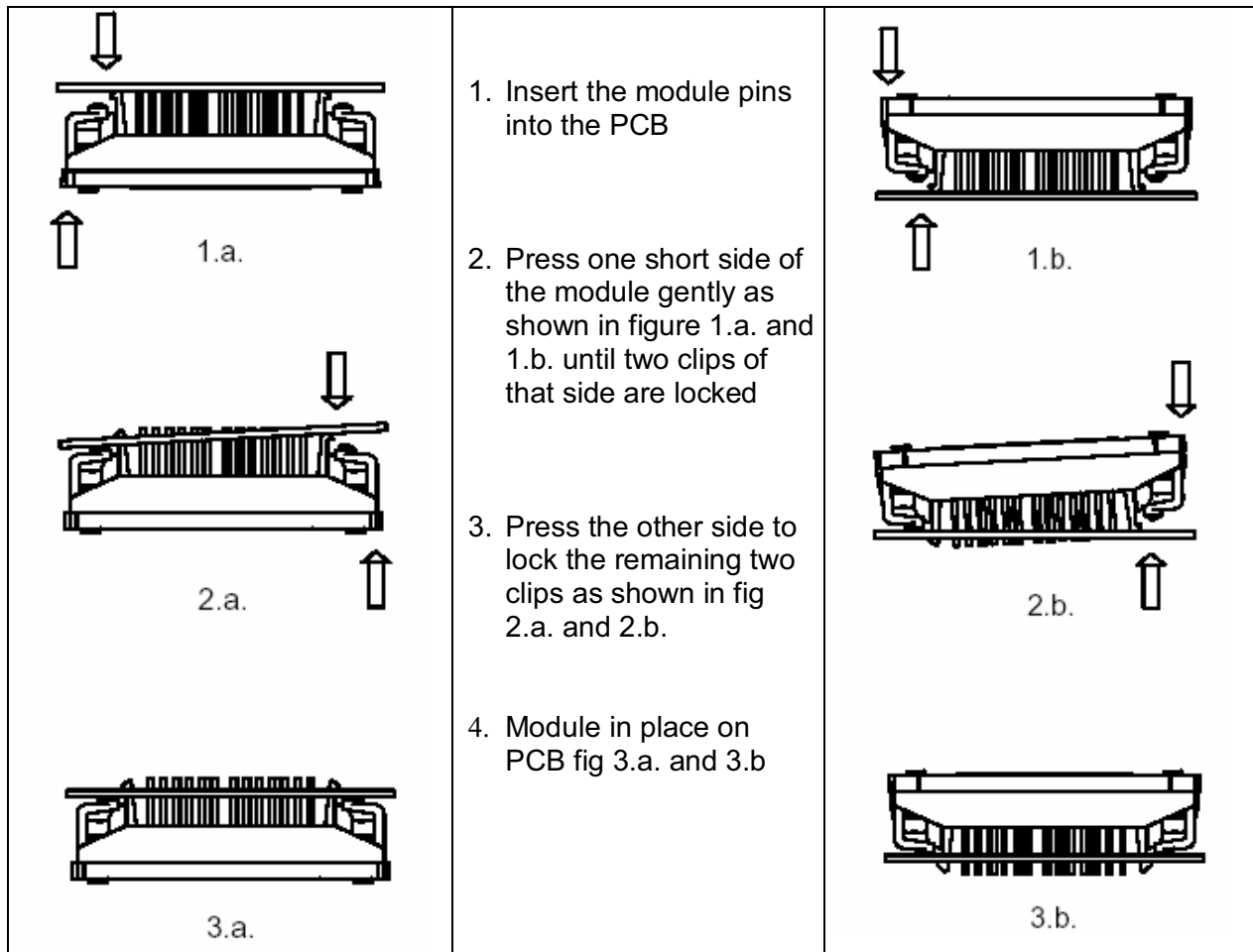

Tyco Electronics does not recommend the use of its products for other applications. Especially it is not recommended to use the modules in life support applications where such use may directly threaten life or injure due to device failure or malfunction.

We reserve the right to make changes of the product at any time without notice, in order to supply the best possible product.