

Fluorescent display tube level meter driver, 16-point \times 2 channel, VU scale, bar display

BA6800AF / BA6805A

The BA6800AF and BA6805A are two-channel, 16-point fluorescent display tube drivers for VU-scale bar-level meters.

They use a dynamic-drive system and are provided with both AC and DC inputs. The AC input mode has a peak hold circuit.

The ICs feature a power-on mute, and the output block can directly drive fluorescent display tubes, so few external components are required.

The grid output duty cycle is 1/8 for the BA6800AF and 1/4 for the BA6805A. Apart from power dissipation, all other characteristics are the same.

●Applications

Level meters for all types of AV equipment

●Features

- 1) Uses dynamic-drive system to display two 16-point channels. Packages are 28-pin DIP (BA6805A) and 28-pin SOP (BA6800AF).
- 2) AC and DC inputs provided. Switching function allows two-mode display.
- 3) Upper 12 points have peak hold function in AC mode (two seconds).
- 4) Power-on mute function.
- 5) Dynamic-drive system reduces the power consumption of the fluorescent display tube power supply.
- 6) Square root compression amplifier built in.

■ 7828999 0019554 12T ■

ROHM

689

Level meter drivers

Audio accessory components

●Block diagram

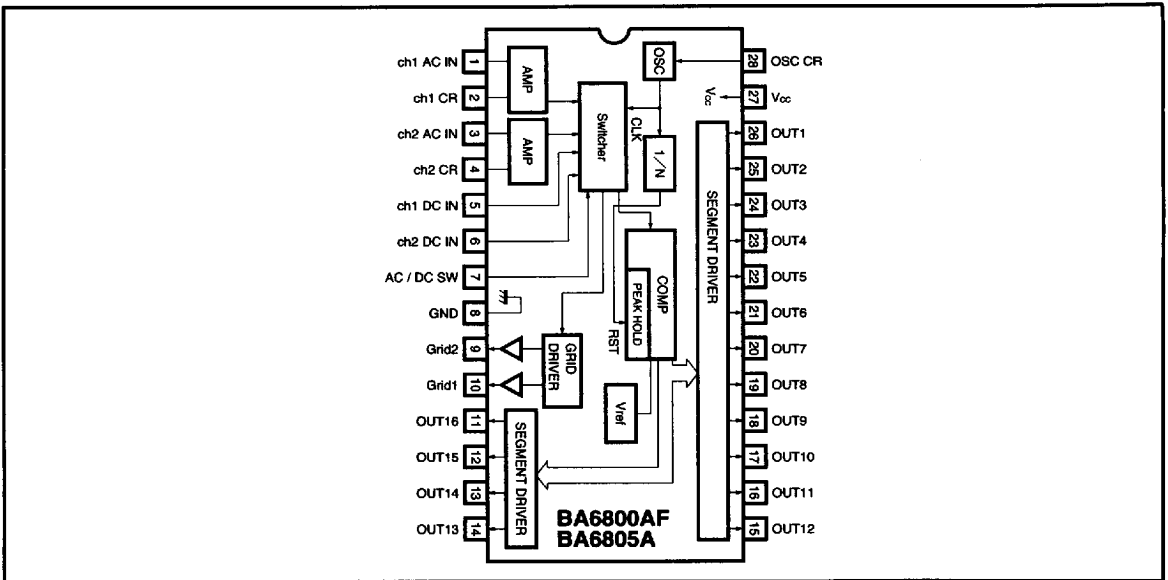

●Absolute maximum ratings (Ta = 25°C)

Parameter	Symbol	Limits	Unit
Supply voltage	V _{CC}	7.0	V
Power dissipation	BA6805A	700*1	mW
	BA6800AF	550*2	mW
Operating temperature	T _{opr}	-20~70	°C
Storage temperature	T _{stg}	-55~125	°C
Output voltage	T _{CC1} , +V _{EE}	36	V

* 1 Reduced by 7mW for each increase in Ta of 1°C over 25°C.

* 2 Reduced by 5.5mW for each increase in Ta of 1°C over 25°C.

●Electrical characteristics (unless otherwise specified Ta = 25°C)

Parameter	Symbol	Min.	Typ.	Max.	Unit	Conditions	Measurement Circuit
Supply voltage	V _{CC}	4.5	5.0	5.8	V		Fig.1
Quiescent current	I _q	—	17	24	mA	—	Fig.1
AC input resistance	R _{INAC}	175	250	325	Ω	1, 3pin	Fig.1
DC input resistance	R _{INDC}	7	10	13	kΩ	—	Fig.1
Oscillator frequency	f _{osc}	1.7	2.0	2.3	kHz	C=0.015 μF, R=30kΩ	Fig.1
Peak hold time	T _{hold}	—	2	—	s	f _{osc} =2kHz	Fig.1
Output duty cycle	BA6800AF	—	1/8	—	—	f _{osc} =2kHz	Fig.1
	BA6805A	—	1/4	—	—	f _{osc} =2kHz	Fig.1
Grid low-level output voltage	V _{GL}	—	0.4	0.8	V	I _G =5mA	Fig.1
Grid output leak current	I _{G leak}	—	—	10	μA	V _{CC} =5V	Fig.1

●Electrical characteristics (unless otherwise specified Ta = 25°C)

Parameter	Symbol	Min.	Typ.	Max.	Unit	Conditions	Measurement Circuit
Segment high-level output voltage	V _{OH}	3.7	4.0	—	V	I _O =2mA	Fig.1
Segment output leak current	I _{Oleak}	—	—	10	μA	—V _{EE} =-31V	Fig.1
Input switching threshold	V _{TH}	2.2	2.5	2.8	V	AC: pin 7 "H", DC: pin 7 "L"	Fig.1
AC sensitivity	V _{INAC}	250	400	630	mV	R _{IN} = 1.5kΩ AC comparator 10 on level	Fig.1
Maximum grid output current	I _{GM}	5	—	—	mA	V _{OL} =0.8V	Fig.1
Maximum segment output current	I _{OM}	2	—	—	mA	V _{OH} =3.7V	Fig.1
AC comparator level 16	V _{C16AC}	8.5	10	12	dB	Pin 11 output	Fig.1
AC comparator level 15	V _{C15AC}	6.0	7	8.5	dB	Pin 12 output	Fig.1
AC comparator level 14	V _{C14AC}	4.0	5	6.0	dB	Pin 13 output	Fig.1
AC comparator level 13	V _{C13AC}	2.5	3	4.0	dB	Pin 14 output	Fig.1
AC comparator level 12	V _{C12AC}	1.5	2	2.5	dB	Pin 15 output	Fig.1
AC comparator level 11	V _{C11AC}	0.5	1	1.5	dB	Pin 16 output	Fig.1
AC comparator level 10	V _{C10AC}	—	0	—	dB	Pin 17 output	Fig.1
AC comparator level 9	V _{C9AC}	-1.5	-1	-0.5	dB	Pin 18 output	Fig.1
AC comparator level 8	V _{C8AC}	-2.5	-2	-1.5	dB	Pin 19 output	Fig.1
AC comparator level 7	V _{C7AC}	-4.0	-3	-2.5	dB	Pin 20 output	Fig.1
AC comparator level 6	V _{C6AC}	-6.0	-5	-4.0	dB	Pin 21 output	Fig.1
AC comparator level 5	V _{C5AC}	-8.5	-7	-6.0	dB	Pin 22 output	Fig.1
AC comparator level 4	V _{C4AC}	-15	-10	-8.5	dB	Pin 23 output	Fig.1
AC comparator level 3	V _{C3AC}	-25	-20	-15	dB	Pin 24 output	Fig.1
AC comparator level 2	V _{C2AC}	-35	-30	-25	dB	Pin 25 output	Fig.1
AC comparator level 1	V _{C1AC}	-55	-40	-35	dB	Pin 26 output	Fig.1
DC comparator level 16	V _{C16DC}	2.76	3.10	3.44	V	Pin 11 output	Fig.1
DC comparator level 15	V _{C15DC}	2.35	2.64	2.93	V	Pin 12 output	Fig.1
DC comparator level 14	V _{C14DC}	2.07	2.33	2.59	V	Pin 13 output	Fig.1
DC comparator level 13	V _{C13DC}	1.86	2.10	2.34	V	Pin 14 output	Fig.1
DC comparator level 12	V _{C12DC}	1.79	2.03	2.27	V	Pin 15 output	Fig.1
DC comparator level 11	V _{C11DC}	1.62	1.88	2.14	V	Pin 16 output	Fig.1
DC comparator level 10	V _{C10DC}	1.51	1.80	2.09	V	Pin 17 output	Fig.1
DC comparator level 9	V _{C9DC}	1.40	1.71	2.02	V	Pin 18 output	Fig.1
DC comparator level 8	V _{C8DC}	1.33	1.66	1.99	V	Pin 19 output	Fig.1
DC comparator level 7	V _{C7DC}	1.23	1.58	1.93	V	Pin 20 output	Fig.1
DC comparator level 6	V _{C6DC}	1.07	1.41	1.75	V	Pin 21 output	Fig.1
DC comparator level 5	V _{C5DC}	0.93	1.26	1.59	V	Pin 22 output	Fig.1
DC comparator level 4	V _{C4DC}	0.77	1.07	1.37	V	Pin 23 output	Fig.1
DC comparator level 3	V _{C3DC}	0.42	0.60	0.78	V	Pin 24 output	Fig.1
DC comparator level 2	V _{C2DC}	0.21	0.33	0.45	V	Pin 25 output	Fig.1
DC comparator level 1	V _{C1DC}	0.11	0.18	0.25	V	Pin 26 output	Fig.1

Notes: (1) The value given above for AC comparator level is measured after 0dB point adjustment.

(2) DC comparator level V_{C(n) DC (Max.)} > V_{C(n+1) DC (Min.)}, but when the nth comparator is off, the (n+1)th comparator is never on.

7828999 0019556 T12



● Measurement circuit

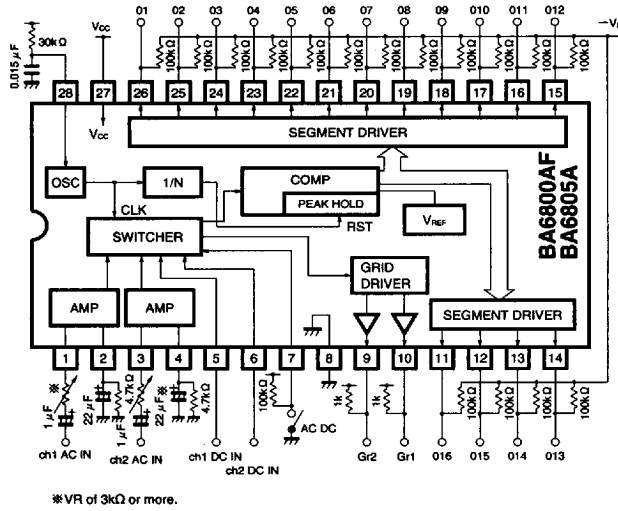

Fig. 1

● Application example

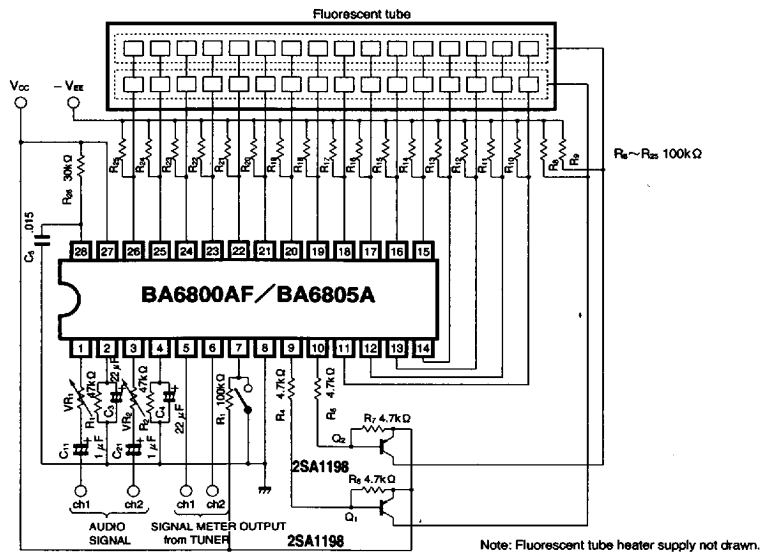

Fig. 2

7828999 0019557 939

● Circuit operation

(1) Input block

The AC input pins are pins 1 and 3, and the DC input pins are pins 5 and 6 (for both the BA6800AF and BA6805A). Pin 7 is used to switch between the AC and DC inputs. When the input to pin 7 is "H", AC input is selected (pins 1 and 3). Therefore, by using pin 7 to switch between the AC and DC modes, the IC can do two jobs. For example, pins 1 and 3 can be used for audio signal input, and pins 5 and 6 can be used as the input for the signal meter output from a tuner (DC). The AC input impedance of pins 1 and 3 is a low 250 Ω (typ.), so connect potentiometers (VR₁ and VR₂) in series with the inputs to adjust the sensitivity and ch1 and ch2 balance.

(2) Peak hold circuit

The BA6800AF and BA6805A have peak hold circuits that temporarily holds peak signal levels in AC input mode.

The peak hold function can be used with the upper 12 points (5 to 16). The peak hold time depends on the oscillator frequency. It is 2 sec. (typ.) for an oscillator frequency of 2kHz.

DC mode does not have a peak hold function.

(3) Grid output

The pin 9 and 10 grid outputs are open-collector NPN transistors. The logic is active low (the fluorescent tube lights when the output is "L"), so connect two PNP transistors Q₁ and Q₂ as shown in the application example circuit to drive the fluorescent tubes (see Fig. 3).

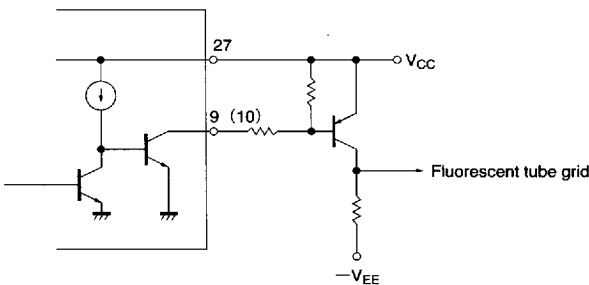

Fig. 3

(4) Segment output block

Pins 11 to 26 are the segment outputs. The output circuits are open-collector PNP transistors. When grid 1 is "L", the ch1 level is output (pin 1 or 5 input level), and when grid 2 is "L", the ch2 level is output (pin 3 or 6 input level). Refer to Fig. 4.

(5) Grid and segment output timing chart. The grid and segment output timing for an oscillator frequency of 2kHz is shown in Fig. 5.

(6) Attack and release times

The response characteristic for AC input signals is set by resistor R₁ and capacitor C₃ for ch1 and resistor R₂ and capacitor C₄ for ch2 (pins 2 and 4). When R₁ = 47k Ω and C₃ = 22 μF, the attack time is about 4ms, and the release time is about 1sec. (same for ch2).

Attack time : Time for the voltage on pins 2 and 4 to rise from 1V to 2.5V when the input goes from no input to 2.6Vrms, then back to no input.

Release time : Time for the voltage on pins 2 and 4 to fall from 2.5V to 1V when the input goes from 2.6Vrms to no input.

(7) Oscillator frequency

The resistor R₂₈ and capacitor C₅ connected to pin 28 determine the oscillator frequency.

The oscillator frequency (f_{osc}) and grid output period (T) are related as follows :

$$T \text{ (ms)} = 16 / f_{\text{osc}} \text{ (kHz)}$$

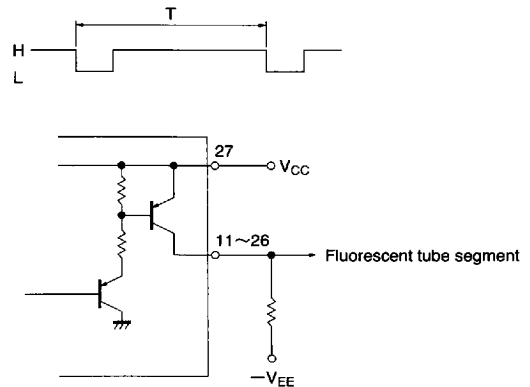

Fig. 4

7828999 0019558 875

● Timing chart

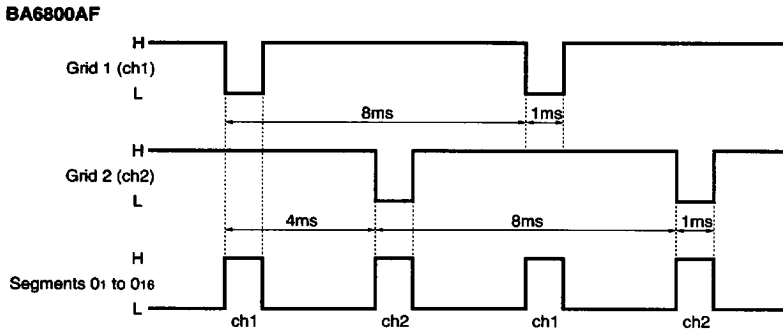

Fig. 5 (a)

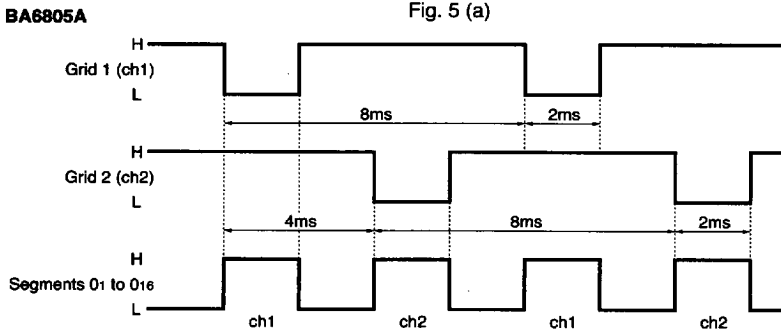

Fig. 5 (b)

● External components (refer to "Circuit operation")

C₁ and C₂ : input coupling capacitors.

VR₁ and VR₂ : AC sensitivity adjustment and balance adjustment (3kΩ recommended).

C₃, R₁, C₄ and R₂ : set the response characteristics with respect to the AC input signal. In the example given, the attack time is about 4mS and the release time is about 1sec.

R₃ : Pullup resistor for the input switching terminal (pin 7).

R₆ and R₇ : resistor for the grid leak current path (I_{gleak}). Set so that I_{gleak} × R₆ (R₇) < 0.6V.

R₄ and R₅ : base bias resistors for Q₁ and Q₂.

Conditions for base bias current (I_b) flow are V_{CC} = 5V and V_F = 0.6V :

$$\frac{R_4}{R_6} < \frac{5-0.6}{0.6} = 7.3$$

the base current is given by the following formula.

$$I_b \text{ (mA)} \doteq \frac{5-0.6}{R_4 \text{ (k}\Omega\text{)}} - \frac{0.6}{R_6 \text{ (k}\Omega\text{)}}$$

$$I_b > \frac{\text{Fluorescent tube grid current/hfe}}{h_{FE}}$$

Set resistors R₄ and R₆ (R₅ and R₇) so that

Q₁ and Q₂ : grid output inverting transistors. Use transistors for which V_{CEO} > V_{CC} + V_{EE}.

R₈ to R₂₅ : Resistors that reverse bias the segments and grid when the fluorescent tube is not lit.

The application example given is for general cases. Select the resistors to suit the characteristics of the fluorescent tube used.

C₅ and R₂₆ : set the oscillator frequency.

Capacitor C₅ should be a component with good temperature characteristics.

● Operation notes

- 1) Adjust the potentiometers VR₁ and VR₂ (connected to pins 1 and 3) to adjust the 0dB input level and the dispersion of ch1 and ch2.
- 2) The temperature characteristic for the lighting limit for the 16th LED is shown in Fig. 6.

- 3) The external resistor R26 connected to the oscillator (pin 28) should be in the range of 20kΩ and 100kΩ. If it is outside this range, oscillation may stop due to the influence of temperature (see Fig. 7).

● Electrical characteristics curves

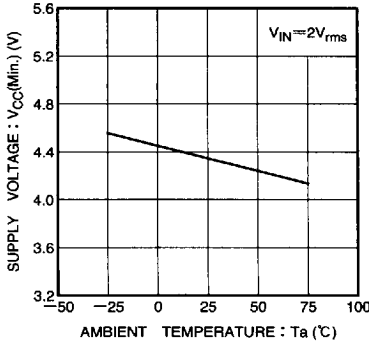

Fig. 6 16th point lighting limit supply voltage vs. ambient temperature

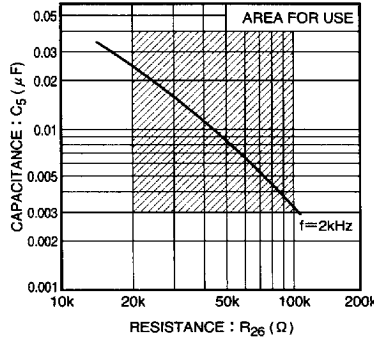

Fig. 7 Value of external components for oscillator (V_{CC} = 5.0V)

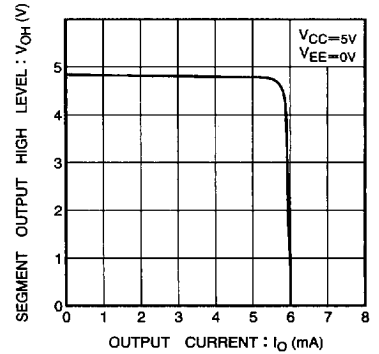

Fig. 8 Segment high-level output vs. output current

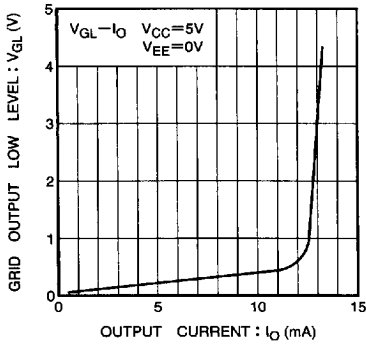
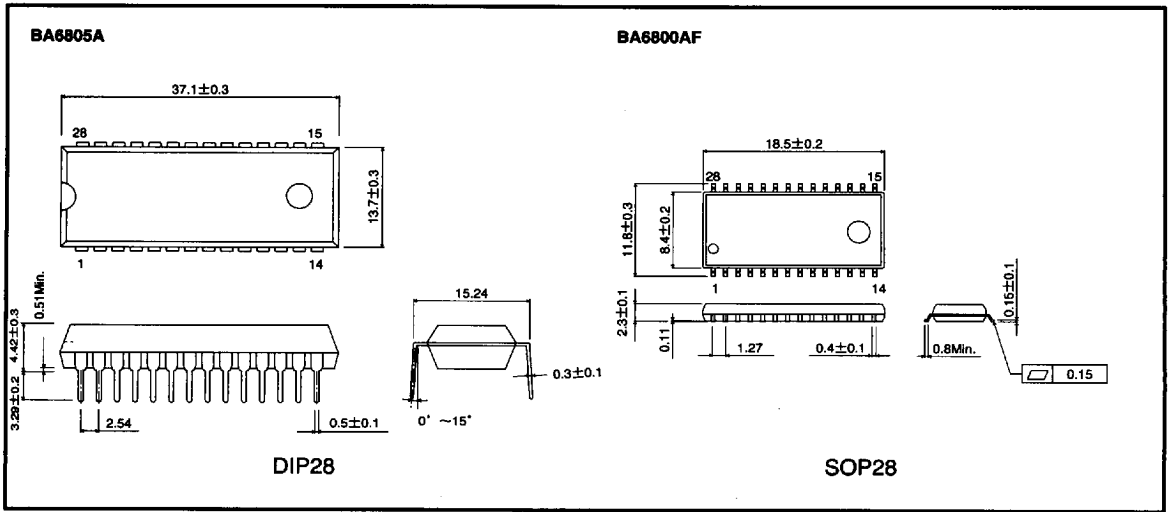

Fig. 9 Grid low-level output vs. output current

Level meter drivers
Audio accessory components

7828999 0019560 423

● External dimensions (Unit: mm)



7828999 0019561 36T