

Chapter 6

FRU (Field Replaceable Unit) list

This chapter gives you the FRU (Field Replaceable Unit) listing in global configurations of AL1511. Refer to this chapter whenever ordering for parts to repair or for RMA (Return Merchandise Authorization).

NOTE : Please note WHEN ORDERING FRU PARTS, that you should check the most up-to-date information available on your regional web or channel(<http://aicsl.acer.com.tw/spl/>). For whatever reasons a part number change is made, it will not be noted in the printed Service Guide. For ACER-AUTHORIZED SERVICE PROVIDERS, your Acer office may have a DIFFERENT part number code to those given in the FRU list of this printed Service Guide. You MUST use the local FRU list provided by your regional Acer office to order FRU parts repair and service of customer machines.

NOTE: To scrap or to return the defective parts, you should follow the local government ordinance or regulations on how best to dispose it, or follow the rules set by your regional Acer office on how to return it.

Chapter 7

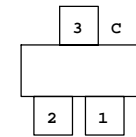

- RTD 3DVCC
- ADC_ 3AVCC
- RTD 3PVCC
- LVDS_3AVCC

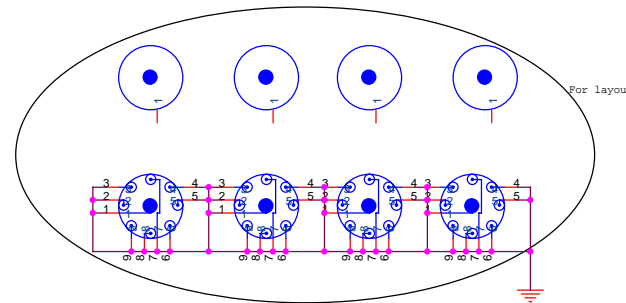
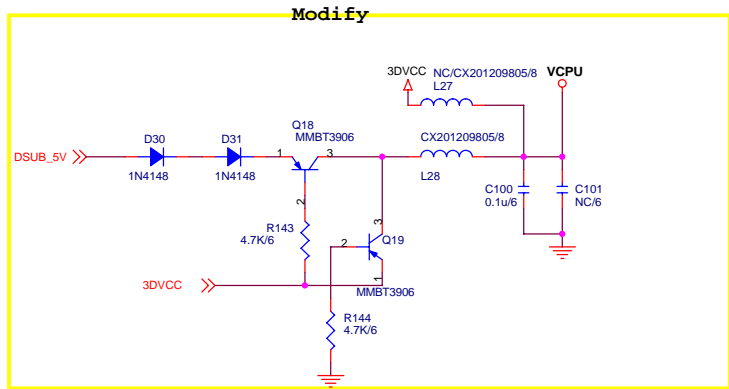
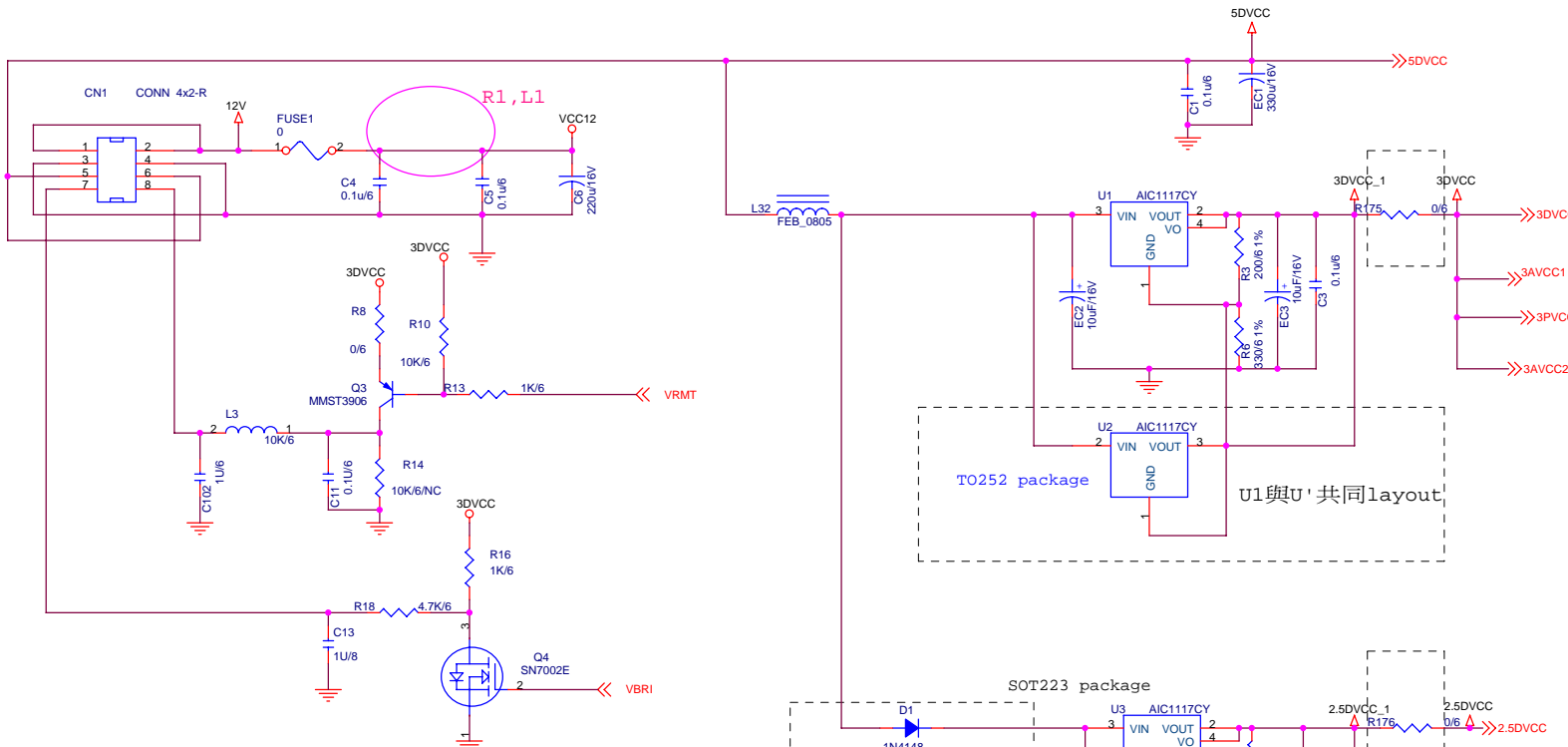

Title		
Power		
Size	Document Number	Rev
	DISPLAY	B2B
Date:	Friday, August 12, 2005	Sheet 3 of 7

PAGE 1 VGA INPUT

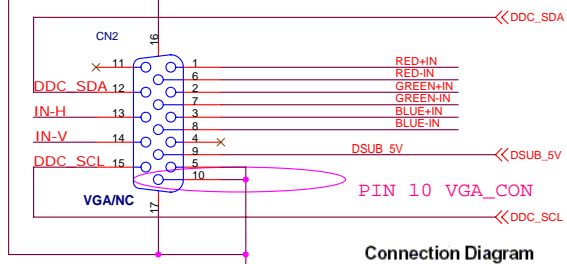

Connection Diagram

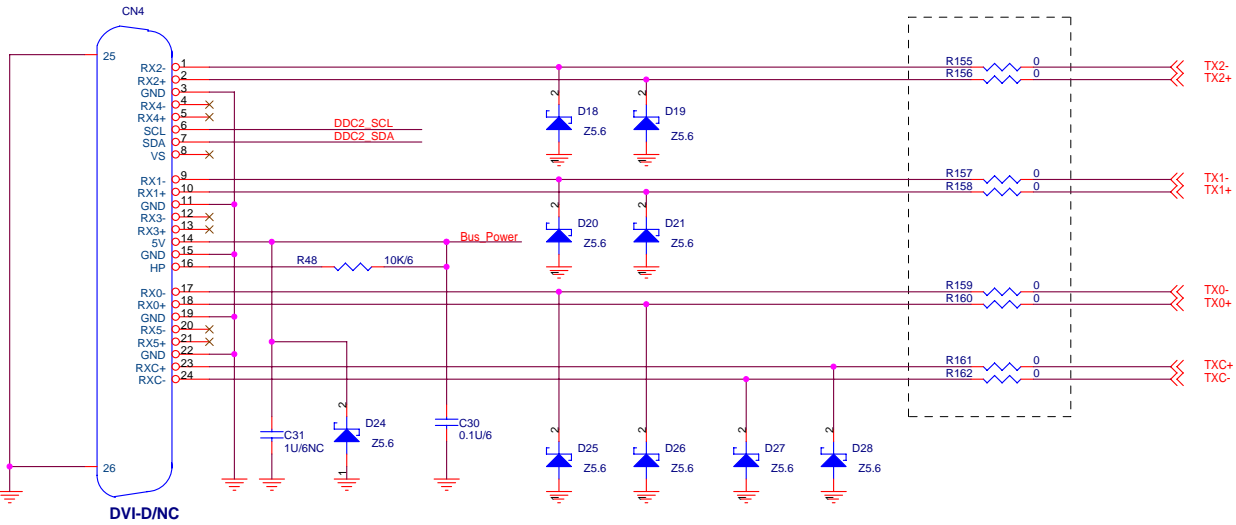
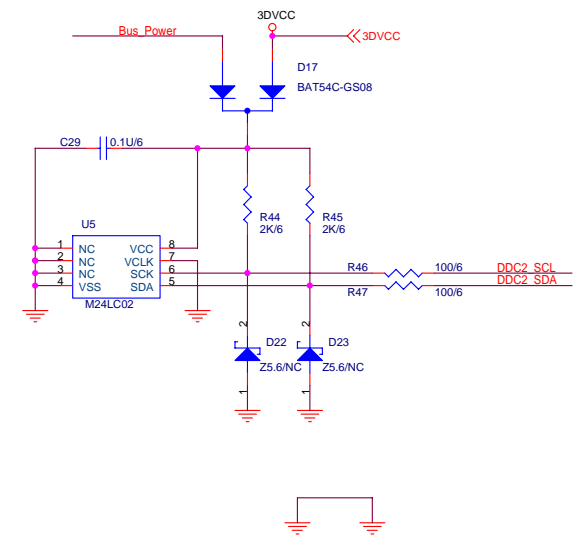
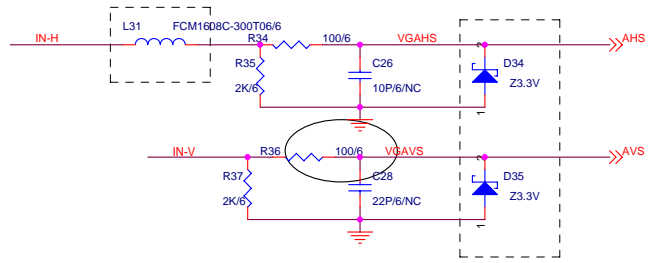
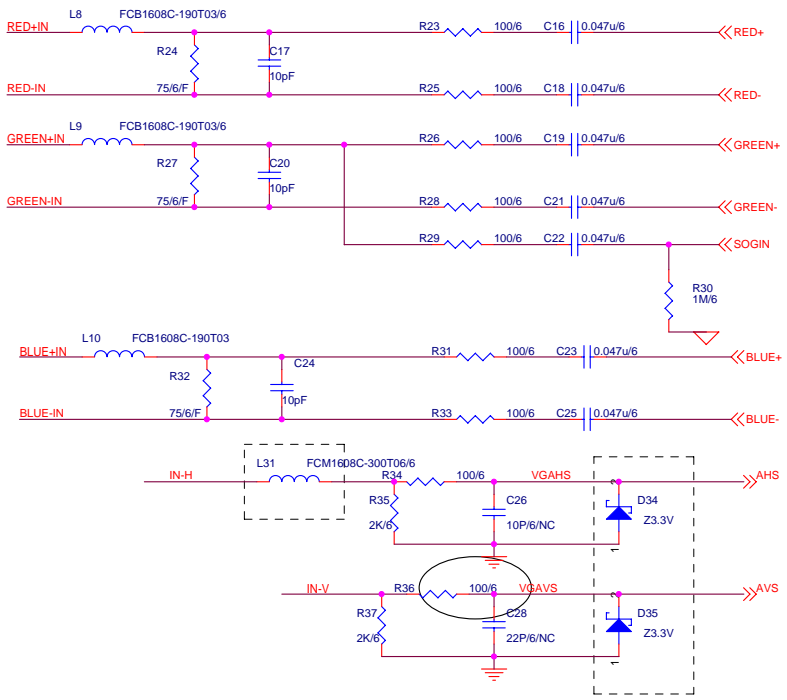
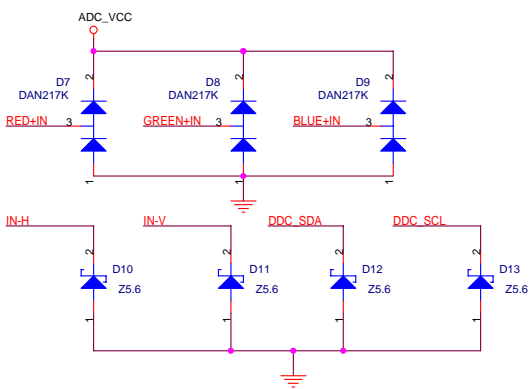
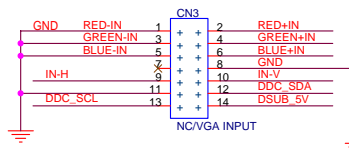
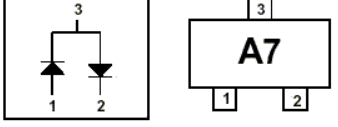

Title			VGA AND DVI INPUT
Size	Document Number	DISPLAY	
Date:	Friday, August 12, 2005	Sheet	4 of 7

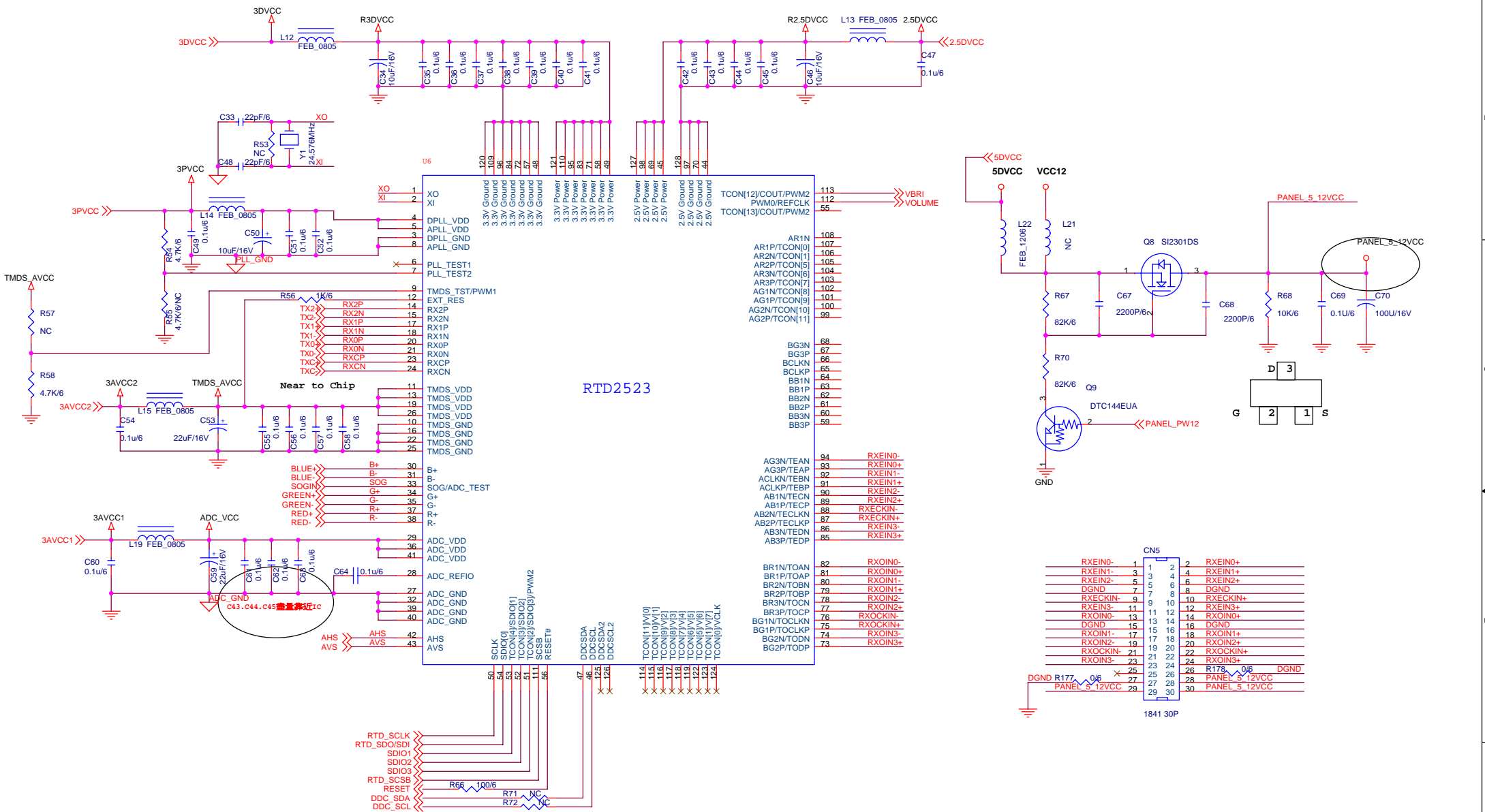

Title			
RTD2523			
Size	Document Number		Rev
	DISPLAY		B2B
Date:	Friday, August 12, 2005	Sheet	5 of 7

PC AUDIO-IN

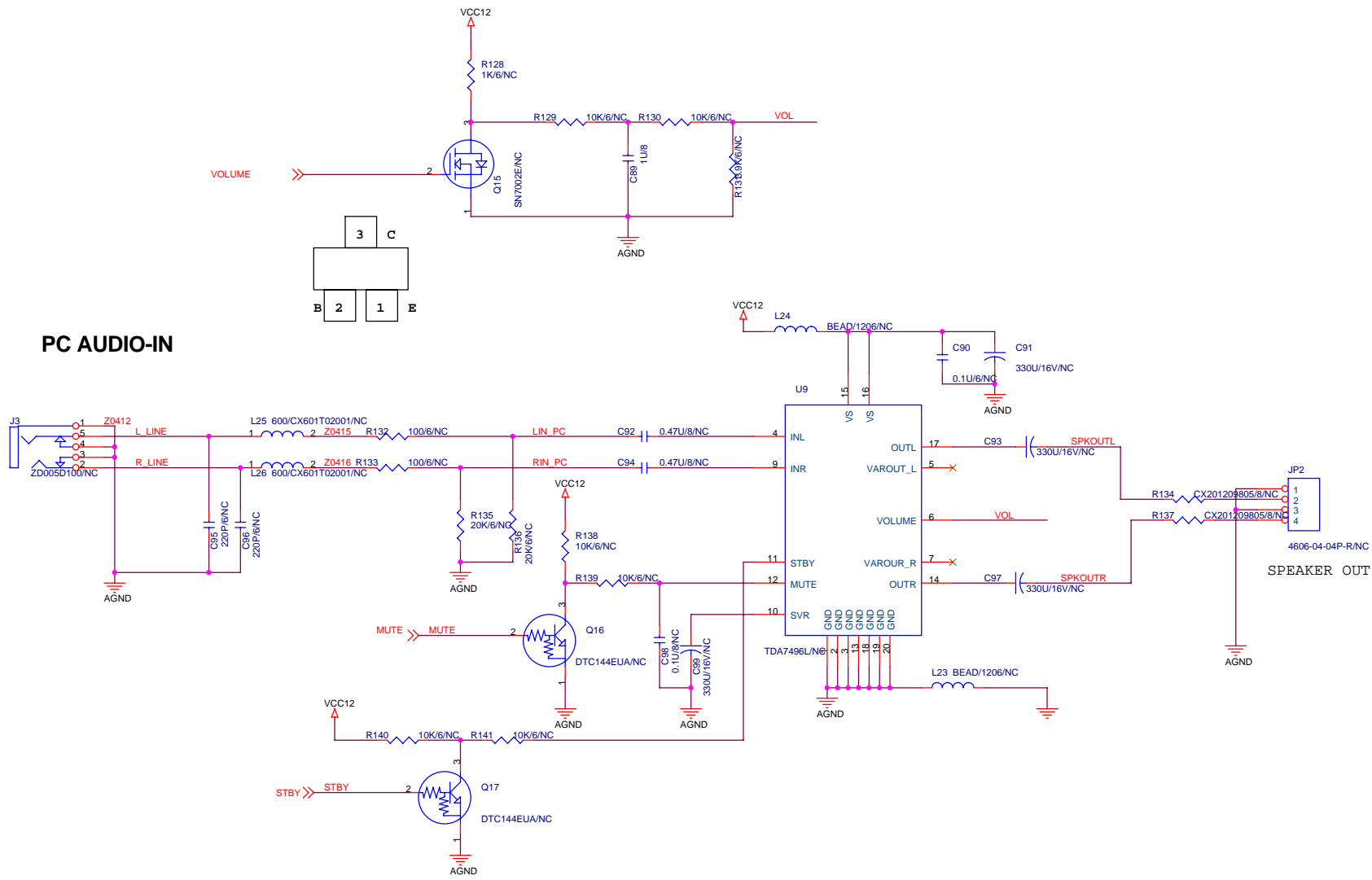

Title		
AUDIO		
Size	Document Number	Rev
	DISPLAY	B2B
Date:	Friday, August 12, 2005	Sheet 7 of 7

