

Description

The BP3102 is a high precision primary-side feedback and regulation controller for LED lighting, it operates in constant current control mode and is designed to work in inductor current discontinuous conduction mode and extremely suitable for flyback convertor under universal input, the output power of system should be less than 5W.

The BP3102 integrates 600V power MOSFET. Since adopting primary sense and feedback control technology, the secondary sense and feedback circuit is eliminated. The loop compensation components are also removed while maintaining stability overall operating conditions. The low component counts and low BOM cost are realized.

Since using the proprietary high accurate current sense method, the BP3102 realizes $\pm 3\%$ accuracy of LED current along with excellent line regulation and load regulation.

The BP3102 offers rich protection functions including LED short circuit protection, LED open circuit protection, die over-temperature protection, VCC over voltage protection, VCC under voltage protection and FB short circuit protection. All the protection features are auto-recovery.

Features

- ◆ Built-in 600V Power MOSFET
- ◆ Constant current control without secondary sense and feedback circuit.
- ◆ $\pm 3\%$ LED current accuracy
- ◆ Ultra low operating current to improve efficiency
- ◆ High resistance feedback resistor to improve efficiency
- ◆ Universal input voltage
- ◆ LED short and open circuit protection
- ◆ VCC under-voltage protection
- ◆ Feedback loop short circuit protection
- ◆ Current sense resistor open circuit protection
- ◆ Over temperature protection
- ◆ No external loop compensation component required
- ◆ Available in SOP-8 package

Applications

- ◆ GU10/E27 LED bulb, spot light
- ◆ Other LED lighting

Typical Application

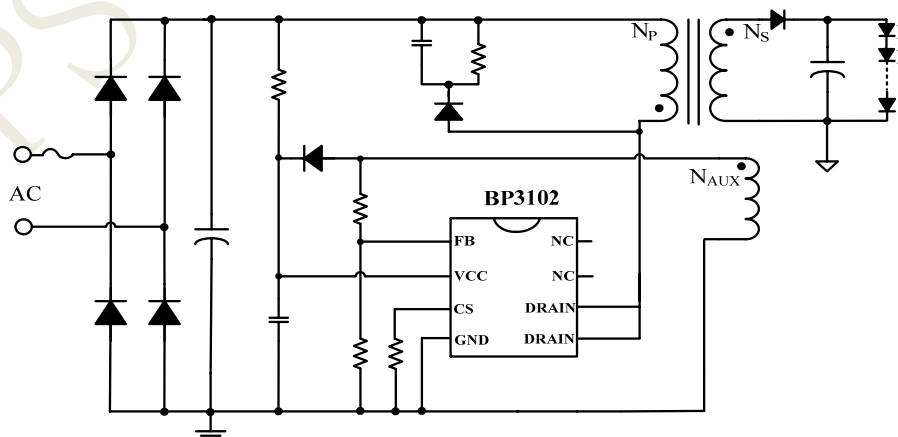

Figure 1. Typical application circuit for BP3102