

SET THE BIAS TRIM POT TO GIVE 80mV (+/- 4mV) AT TP1 & TP2 WRT GROUND. BALANCE THE ERROR BETWEEN TP1 & TP2 EITHER SIDE OF 80mV.  
 EXAMPLE: 78mV AT TP1 AND 82mV AT TP2.

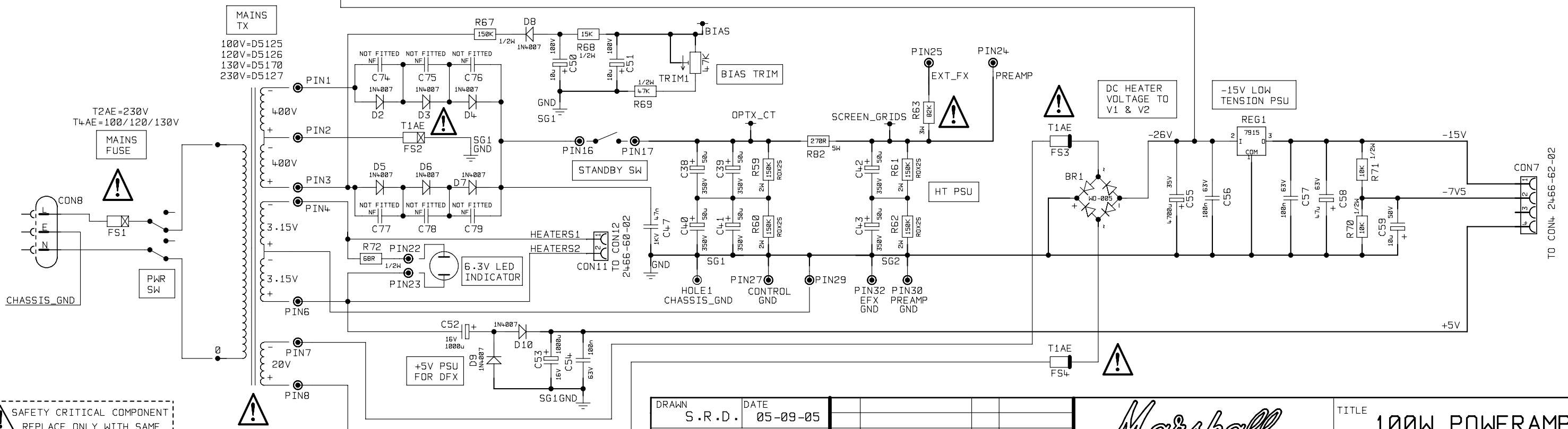
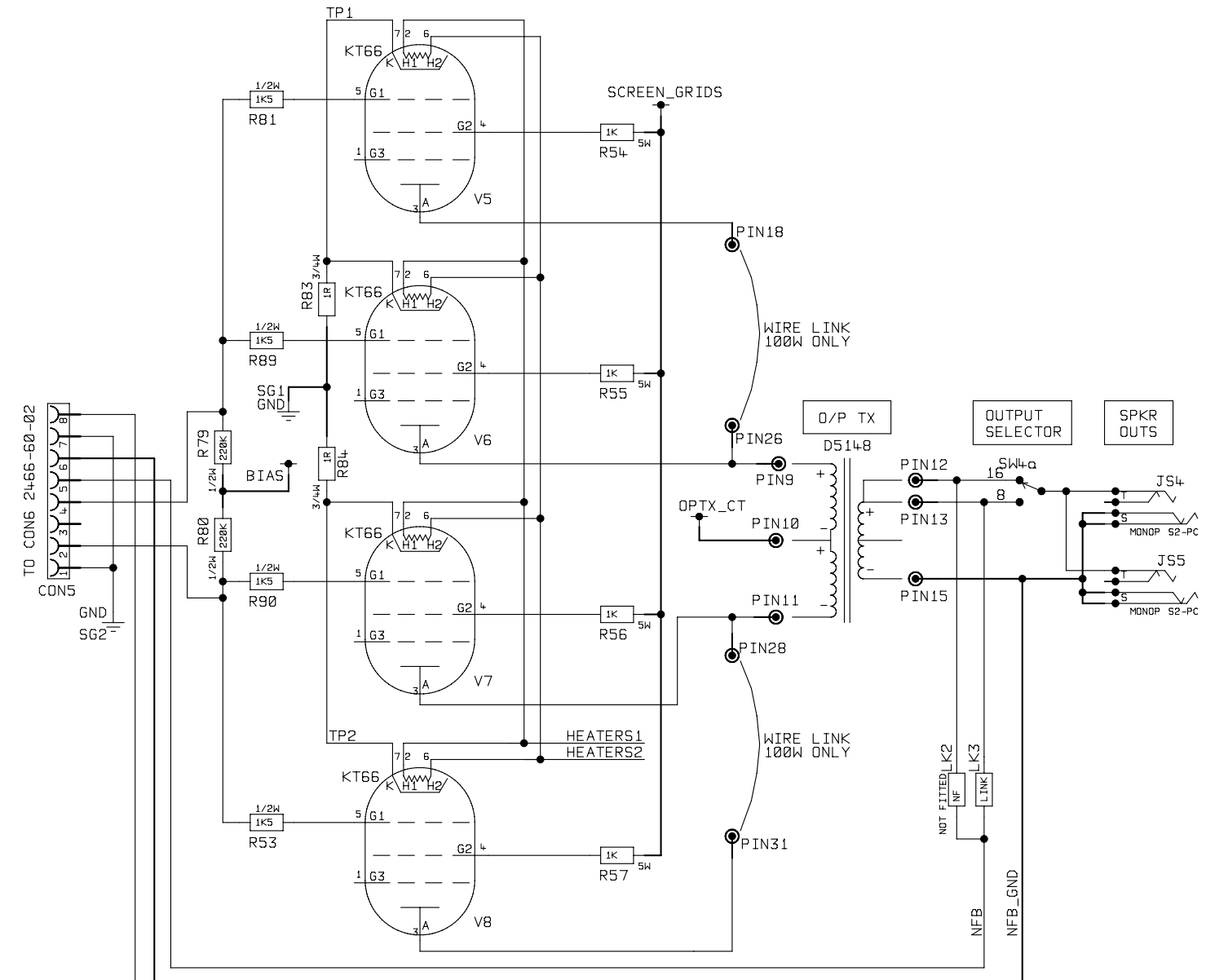

**SAFETY CRITICAL COMPONENT**  
 REPLACE ONLY WITH SAME TYPE AND RATING

DRAWN	S.R.D.	DATE	05-09-05
MODEL	2466		
ISS	3	3 C39 C42 DUAL PITCH	23-11-06
ISS	ECD NUMBER	CHK	DATE

*Marshall*  
 © MARSHALL AMPLIFICATION PLC  
 DENBIGH ROAD, BLETCHLEY, MILTON KEYNES, MK1 1DQ.  
 TEL (01908) 375411 FAX (01908) 376118

TITLE	100W POWERAMP	
DWG.No	2466-61-02	ISS 3