



偉詮電子股份有限公司
Weltrend Semiconductor, Inc.

WT7514L

Data Sheet

REV. 1.30

April 12, 2004

The information in this document is subject to change without notice.
©Weltrend Semiconductor, Inc. All Rights Reserved.

新竹市科學工業園區工業東九路 24 號 2 樓
2F, No. 24, Industry E. 9th RD., Science-Based Industrial Park, Hsin-Chu, Taiwan
TEL:886-3-5780241 FAX:886-3-5794278.5770419
Email:support@weltrend.com.tw

GENERAL DESCRIPTION

The WT7514L is a pulse-width modulation (PWM) control circuit with complete protection circuits for used in the SMPS (Switched Mode Power Supply). It contains various functions, which are Over Voltage Protection, Under Voltage Protection, Power Good Output (PGO), Remote On/Off control and etc. It can minimize external components of switching power supply systems in personal computer.

Over Voltage Protection (OVP) monitors 3.3V, 5V, 12V and PT input voltage level. Under Voltage Protection (UVP) monitors 3.3V, 5V and 12V input voltage level. Power Good Output monitors the voltage level of power supply.

FEATURES

- Complete PWM Control and Protection Circuitry
- Over Voltage Protection for 3.3V / 5V / 12V / PT
- Under Voltage Protection for 3.3V / 5V / 12V
- Various PG Time Delay by TPG
- Power Good Output is Open Drain Output
- PWM Control Output are Open Drain Output
- 250 mS Time Delay for UVP
- Remote ON/OFF function De-bounce Time
- Power Good Output with Hysteresis
- 16-Pin Dual In-line Package

PIN CONFIGURATION

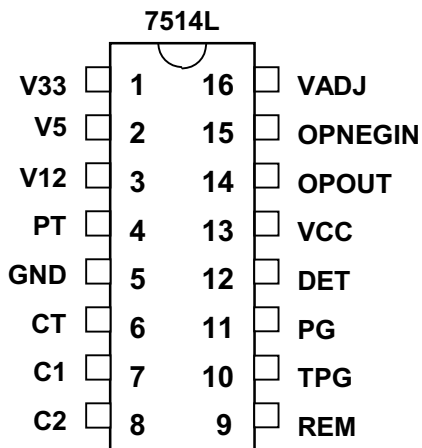

Ordering Number	Package Type
WT7514L-N160WT	DIP 16

PIN DESCRIPTION

Pin No.	Pin Name	TYPE	FUNCTION
1	V33	I	OVP/UVI INPUT FOR 3.3V
2	V5	I	OVP/UVI INPUT FOR 5V
3	V12	I	OVP/UVI INPUT FOR 12V
4	PT	I	EXTRA OVP INPUT PROTECTION
5	GND	P	GROUND
6	CT	---	OSCILLATION FREQUENCY BY SETTING CAP
7	C1	O	OUTPUT 1
8	C2	O	OUTPUT 2
9	REM	I	REMOTE ON/OFF INPUT. IF REM="LOW" THAT MEANS THE MAIN SMPS IS OPERATION. WHEN REM="HIGH", THE MAIN SMPS IS TURNED-OFF.
10	TPG	---	POWER GOOD DELAY TIME
11	PG	O	POWER GOOD SIGNAL. IF PG="HIGH" MEANS "POWER GOOD" AND PG="LOW" MEANS "POWER FAIL".
12	DET	I	POWER GOOD SIGNAL INPUT
13	VCC	P	SUPPLY VOLTAGE
14	OPOUT	O	OP COMPENSATION OUTPUT
15	OPNEGIN	I	OP COMPENSATION NEGATIVE INPUT
16	VADJ	I	VOLTAGE ADJUST

BLOCK DIAGRAM

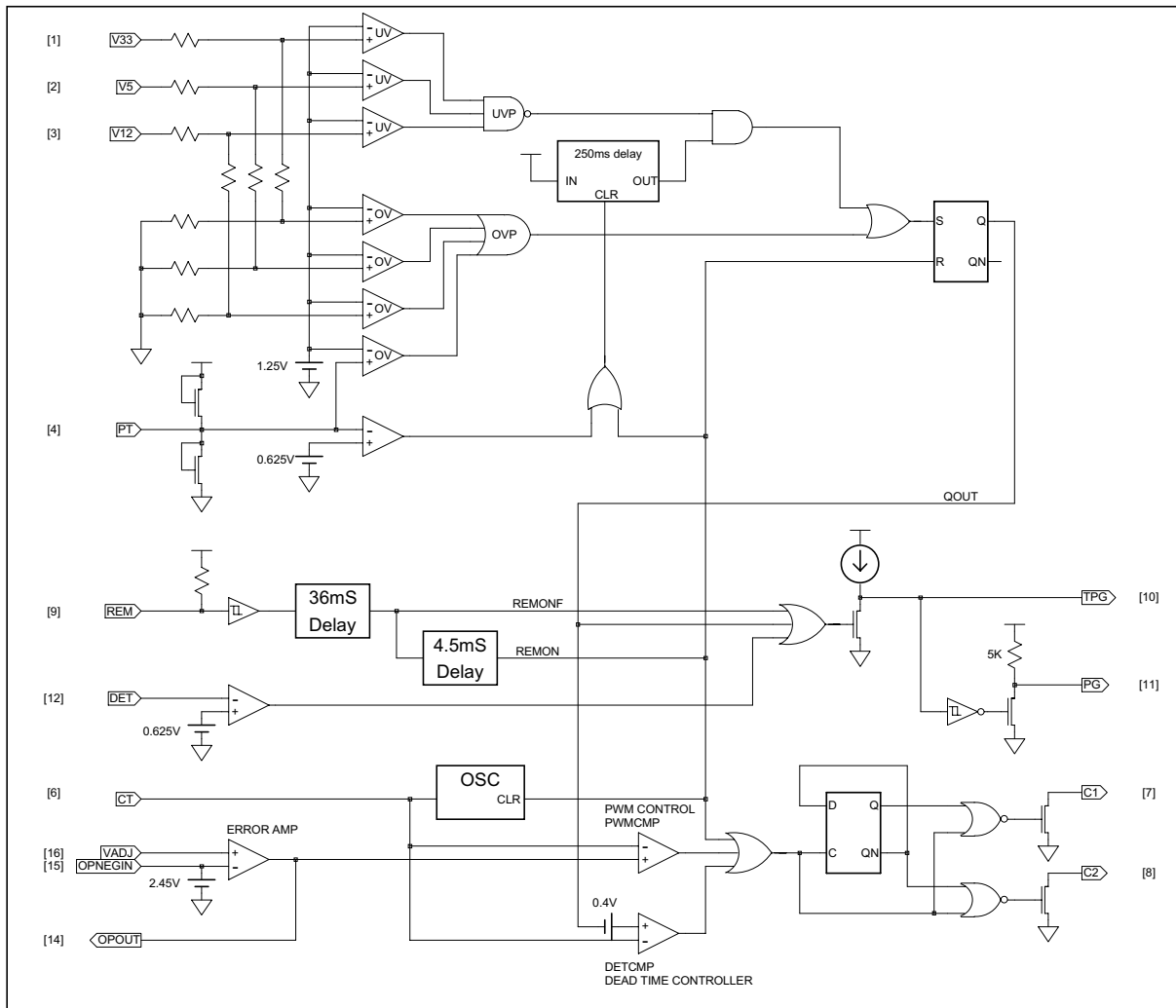

ABSOLUTE MAXIMUM RATINGS, VCC=5.5V

CHARACTERISTICS	SYMBOL	VALUE	Unit
Supply voltage	VCC	5.5	V
Drain output voltage	Vcc1, Vcc2	5.5	V
Drain output current	Icc1, Icc2	200	mA
Power dissipation	Pd	200	mW
Operating temperature	Topr	-10 ~ +70	°C
Storage temperature	Tstg	-65 ~ +150	°C



ELECTRICAL CHARACTERISTICS, TA=25°C, V_{CC}=5V,

CHARACTERISTICS	SYMBOL	TEST CONDITION	Min.	Typ.	Max.	Unit
-----------------	--------	----------------	------	------	------	------

DEAD TIME CONTROL SECTION

INPUT THRESHOLD VOLTAGE	Vthdt	ZERO DUTY CYCLE		3.0	3.3	V
		MAX. DUTY CYCLE		0.1		

ERROR AMP SECTION

CLOSE LOOP VOLTAGE GAIN		0.5V ~ 3.5V		65		dB
CROSS OVER POINT		0dB		320		KHZ
OPNEG BIAS VOLTAGE		OPNEG OPEN	2.38	2.45	2.52	V

OUTPUT SECTION

OUTPUT SATURATION VOLTAGE	Vdssat	Id=200mA		1.1	1.3	V
DRAIN OFF-STATE CURRENT	Idoff	Vcc=Vd=Vs=0V		2	10	uA
RISING TIME	Tr			100	200	ns
FALLING TIME	Tf			50	200	ns

PROTECTION SECTION

OVER VOLTAGE PROTECTION (OVP)	V33		3.8	4.1	4.3	V
	V5		5.8	6.2	6.6	V
	V12		4.41	4.64	4.90	V
	PT		1.2	1.25	1.3	V
UNDER VOLTAGE PROTECTION (UVP)	V33		1.78	1.98	2.18	V
	V5		2.70	3.00	3.30	V
	V12		2.11	2.37	2.63	V
UVP DISABLE VOLTAGE	PT		0.55	0.62	0.68	V
UVP DELAY TIME	Td.uvp		100	250	500	ms

REMOTE ON/OFF SECTION

REM HIGH INPUT VOLTAGE	Vremh		2.0			V
REM LOW INPUT VOLTAGE	Vreml				0.8	V
REM PULL HIGH VOLTAGE	Vremo		2.0		5.25	V
REM DELAY TIME	Trem		30	36	42	ms
REM OFF DELAY TIME	Toff		3.5	4.5	5.5	ms

POWER GOOD SECTION

DETECTING INPUT VOLTAGE	Vdet		0.55	0.62	0.68	V
PG OUTPUT PULL-UP RESISTOR	Rpup, pg			5		KΩ
PG OUTPUT LOAD RESISTOR	Rpg		0.5	1	2	KΩ
CHARGING CURRENT FOR TPG	Ichg.tpg			30		uA
PG DELAY TIME	Td.pg	C=2.2uF	100	250	500	ms
OUTPUT SATURATION VOLTAGE	Vsat.pg	Ipg=10mA		0.2	0.4	V

TOTAL DEVICE

STANDBY SUPPLY CURRENT	Icc			10	20	mA
------------------------	-----	--	--	----	----	----

OSCILLATION SECTION

OSCILLATION FREQUENCY	Fosc	CT=2200P	50	60	70	KHZ
FREQ. CHANGE WITH TEMP.	Fosc/T	CT=2200p		2		%

APPLICATION NOTE

1. Input impedance:

Pin No.	Pin Name	Input impedance
1	V33	52KΩ
2	V5	81KΩ
3	V12	52KΩ
4	PT	279KΩ (VGS1=4.12V) 59.8KΩ (VGS2=0.88V) (VCC=5V, PT=0.88V)

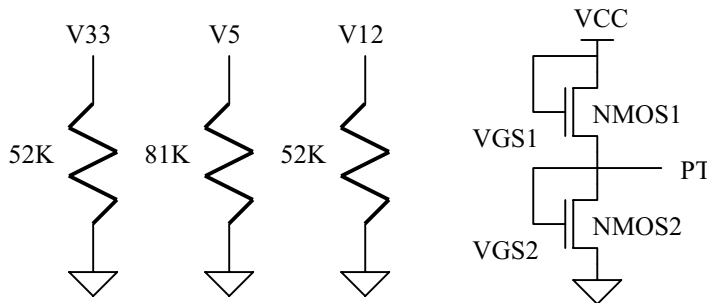

2. Operation Frequency:

The period of the sawtooth is T_{OSC} :

$$I_{CHARGE} = (1.25V / 5.8 K\Omega) * 2 = 430\mu A$$

$$T_{OSC} = (3.3V * C_T) / I_{CHARGE} = (3.3V * 2200pF) / 430\mu A$$

$$F_{OSC} = 1 / T_{OSC} = 59 KHZ$$

For Push-Pull applications:

$$F_{PUSH-PULL} = 1 / 2 T_{OSC}$$

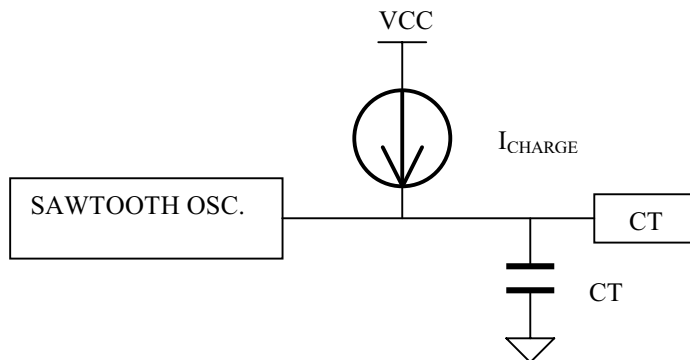

3. REMOTE ON/OFF :

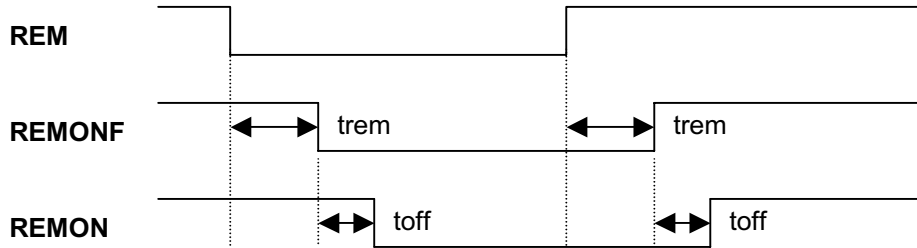

4. Under Voltage Protection Delay Time :

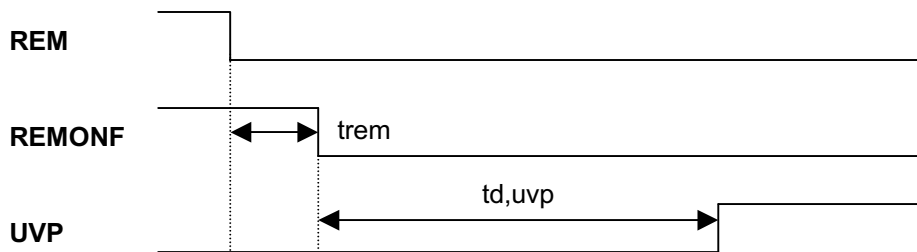

5. Pulse Width Modulation Block :

The output pulse width modulation is generated by comparison of the saw-tooth waveform from the capacitor C_T to the feedback of the voltage.

Therefore, an increase in feedback control signal amplitude cause a linear decrease of the output pulse width. The timing diagram is shown as below:

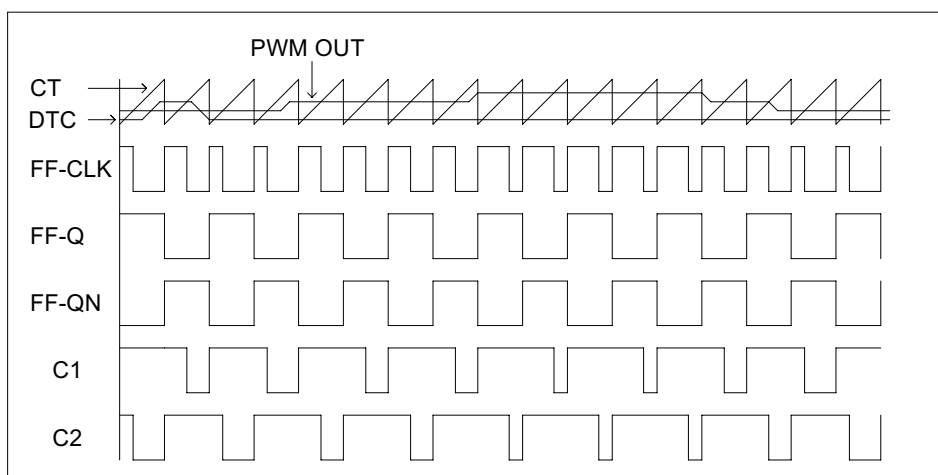

6. The function of “PT”: (Default floating $V_{PT} = 0.8V$)

This signal is prepared for extra Over Voltage Protection Input ($V_{PT} > 1.25V$) or another Disable Under Voltage Protection function ($V_{PT} < 0.62V$)

7. Reference Application Circuit:

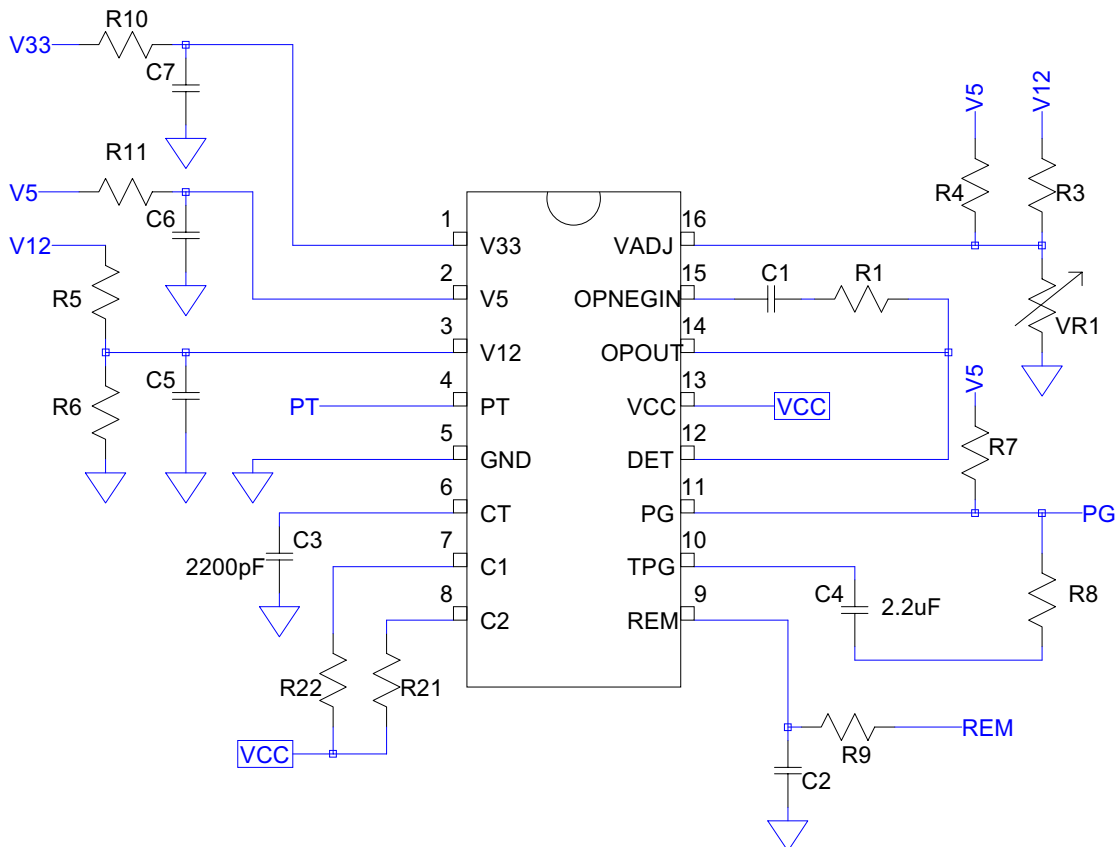

MECHANICAL INFORMATION

PLASTIC DUAL-IN-LINE PACKAGE

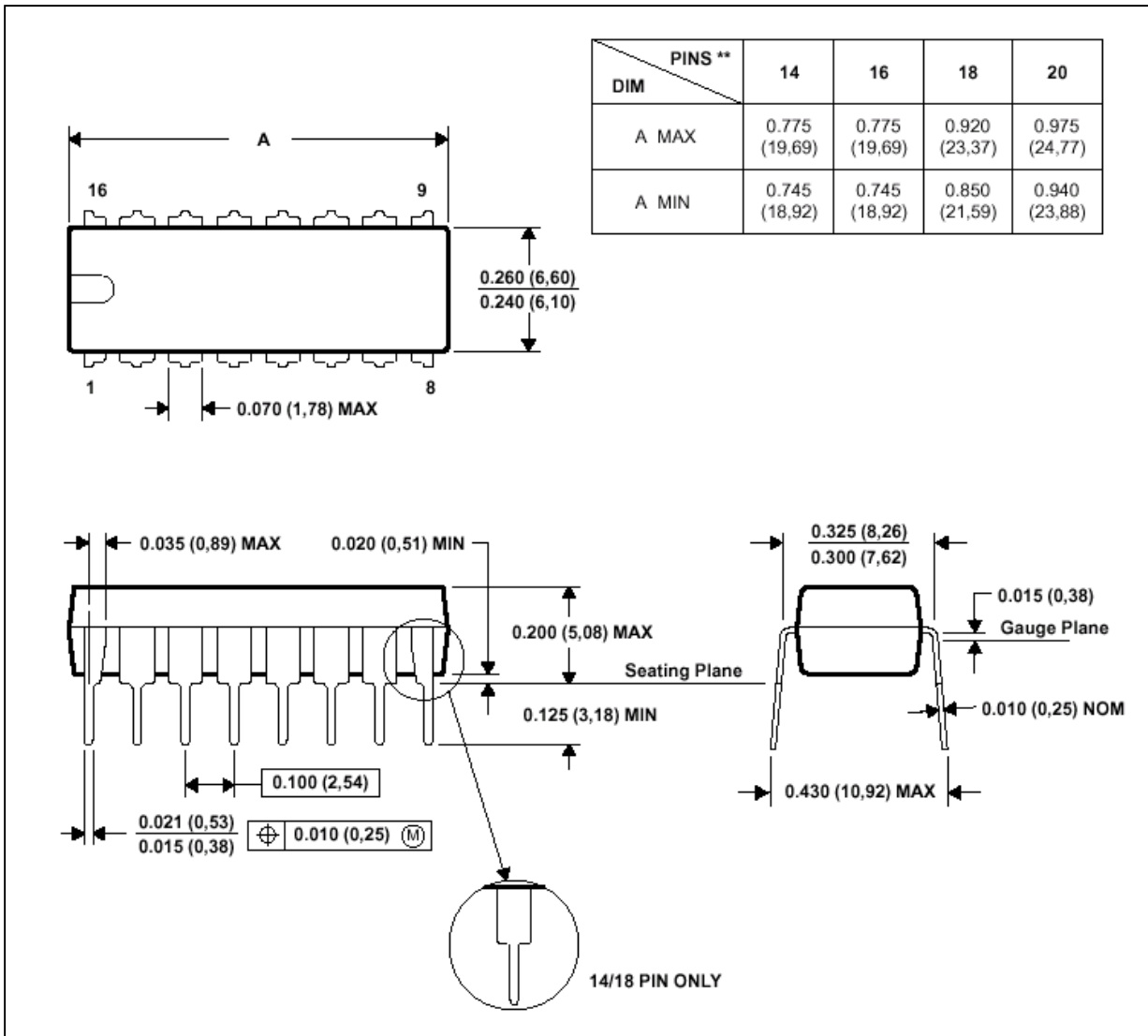

NOTE 1 : All linear dimensions are in inches (millimeters) .

NOTE 2 : This drawing is subject to change without notice.

NOTE 3 : Falls within JEDEC MS-001