

CGR18650A: Cylindrical Model

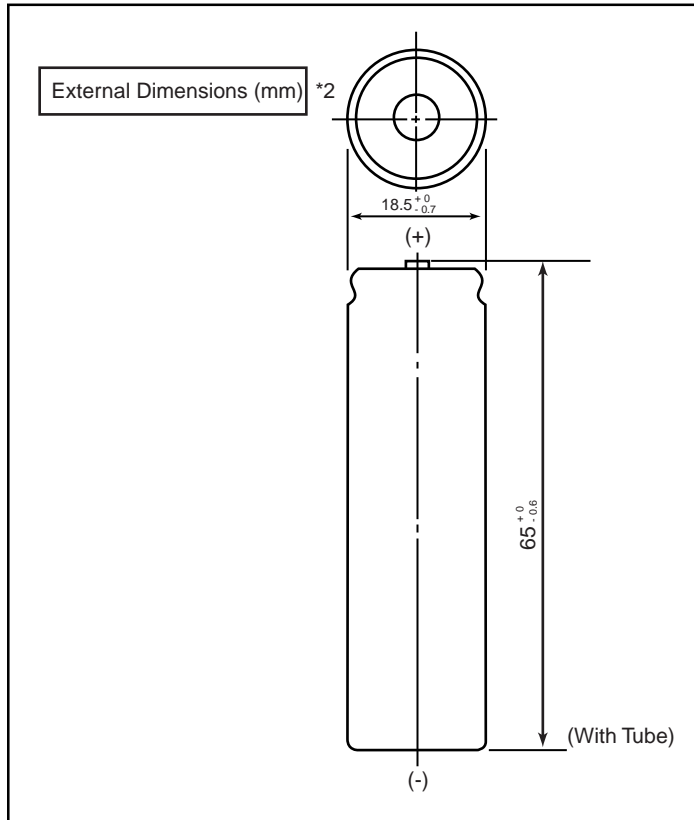

Specifications

Nominal Voltage		3.6V
Standard Capacity *1		2000mAh
Dimensions *2	Diameter	18.5 +0/-0.7mm
	Height	65.0 +0/-0.6mm
	Weight	Approx. 43g

*1 After a fresh battery has been charged at constant voltage/constant current (4.2 V, 1190 mA (max), 2 hours, 20°C), the average of the capacity (ending voltage of 3 V at 20°C) that is discharged at a standard current (370 mA).

*2 Dimensions of a fresh battery

Discharge Characteristics

