

Thermocouple Circuit Using MCP6V01 and PIC18F2550

Author: Yang Zhen and Ezana Haile
Microchip Technology Inc.

INTRODUCTION

Target Audience

This application note is intended for hardware and firmware design engineers who need to accurately measure Type-K Thermocouple voltage and convert it to degree Celsius ($^{\circ}\text{C}$).

Goals

- Accurately measure Type-K Thermocouple Electromotive Force (EMF)
- Provide Low-Cost and accurate thermocouple solution

Description

This application note shows how to use a difference amplifier system to measure EMF voltage at the cold junction of thermocouple in order to accurately measure temperature at the hot junction. This can be done by using the MCP6V01 auto-zeroed op amp because of its extremely low input offset voltage (V_{OS}) and very high common mode rejection ratio (CMRR). This solution minimizes cost by using resources internal to the PIC18F2550, such as 10-bit ADC and 4-bit adjustable reference, to achieve less than 0.1°C resolution from a measurement range of -100°C to 1000°C .

Related Reference Design Board

The measurements for this application note were made on the MCP6V01 Thermocouple Auto-Zeroed Reference Design Board which is discussed in the user's guide (DS51738)^[9]. This board is further described by:

- Order Number: MCP6V01RD-TCPL
- Assembly Number: 114-00169

THERMOCOUPLE OVERVIEW

Thermocouples are constructed of two dissimilar metals such as Chromel and Alumel (Type-K). The two dissimilar metals are bonded together on one end of the wires with a weld bead, or Hot Junction. The junction point is the temperature sensor. Temperature difference between the Hot Junction and the open junction, Cold Junction, generates measurable voltage between the two terminals of the open junction. This voltage is commonly called the Electromotive Force (EMF) voltage, or Seebeck Effect. This EMF voltage does not require excitation current or voltage. If the difference in temperature between the open and closed end of the Thermocouple wires increases, then the EMF voltage increases proportionally.

The Type-K thermocouple used in the circuit is from OMEGA with part number 5SRTC-TT-K-24-36. The EMF voltage and temperature range of Type-K thermocouple are shown in Figure 1. The voltage shown is referenced to 0°C .

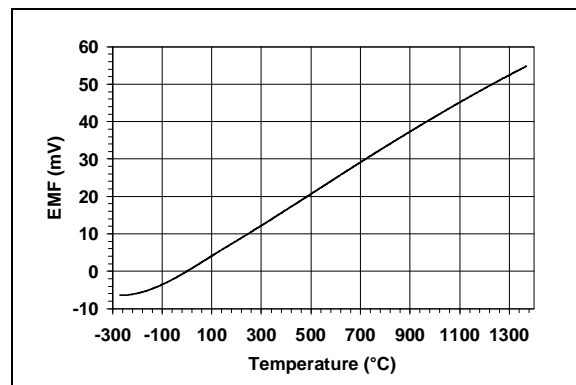

FIGURE 1: EMF Voltage vs. Temperature.

From Figure 1, it can be summarized that the EMF voltage has relatively small magnitude (millivolts). Consequently, the signal conditioning portion of the electronics requires an analog gain stage. In addition, the signal conditioning circuit must have absolute reference voltage in order to measure temperature with absolute accuracy.

AN1306

SYSTEM BLOCK DIAGRAM

Figure 2 shows the system block diagram of the solution. The difference amplifier uses MCP6V01 auto-zeroed op amp to amplify the thermocouple's EMF voltage.

The CV_{REF} is an internal comparator voltage reference of PIC18F2550, which is a 16-tap resistor ladder network that provides a selectable reference voltage. It has low accuracy and high variable output resistance. The buffer amplifier eliminates the output impedance loading effect and produces the voltage V_{SHIFT} that shifts the V_{OUT1} .

The V_{SHIFT} is brought back into the PIC18F2550, sampled and calibrated by the internal ADC, then used to adjust measured V_{OUT1} , so that the temperature

range is segmented into 16 smaller ranges. This gives a greater range (-100°C to +1000°C) and better accuracy.

The MCP1541 provides a reference voltage of 4.1V which references the PIC18F2550's internal 10-bit ADC. The 2nd order RC low-pass filter reduces noise and aliasing at the ADC input.

The MCP9800 senses temperature at the thermocouple connector, or cold-junction. It should be located as close as possible to the connector on the PCB. This measurement is used to perform cold junction compensation for the thermocouple measurement.

The Thermal Management Software is used to perform data acquisition to show the real-time temperature data.

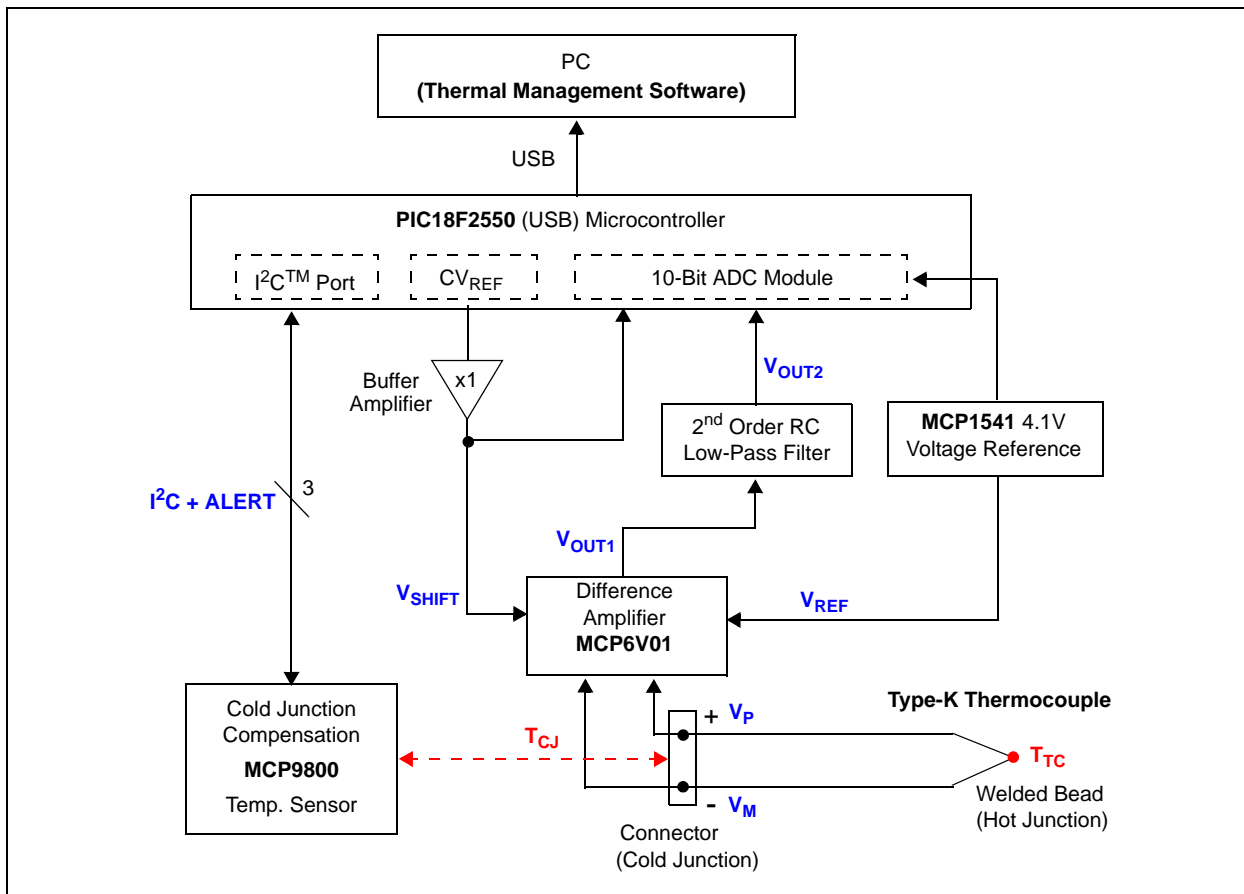

FIGURE 2: System Block Diagram.

HARDWARE CIRCUITS

Voltage Sensors With Common Mode Noise

Any remote voltage sensor with differential output is usually subject of high common-mode noise. An example would be a temperature sensor for an engine, such as a thermocouple sensor.

EQUATION 1:

$$V_{CM} = \frac{V_1 + V_2}{2} \quad V_{DM} = V_1 - V_2$$

Where:

V_{CM} = Common Mode Voltage
 V_{DM} = Difference Mode Voltage
 V_1, V_2 = Differential Outputs of Remote Voltage Sensor

Figure 3 shows voltage sensors with high common mode noise.

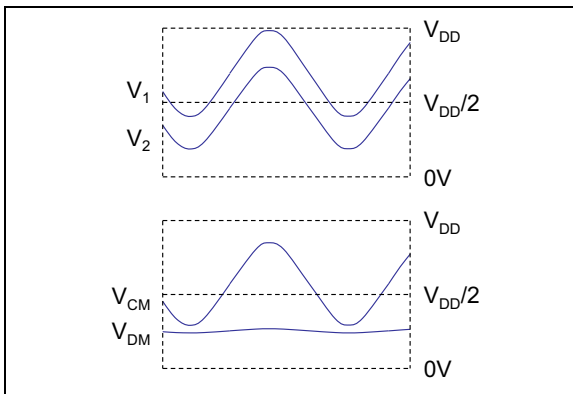

FIGURE 3: Voltage Output Sensor with High Common Mode Noise.

Figure 4 shows voltage sensor with low common mode noise.

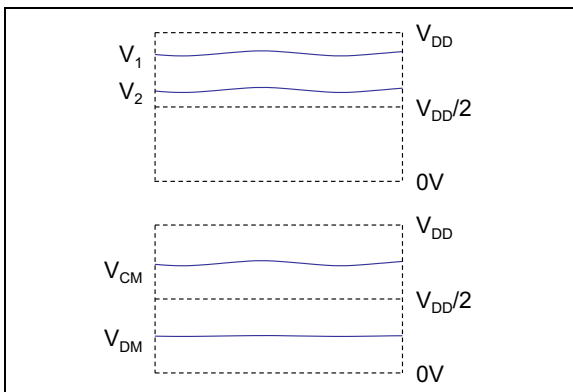

FIGURE 4: Local Sensors with Low Common Mode Noise.

Common mode noise is reduced by shielding, PCB layout, and using a difference or instrumentation amplifier. In this application note, we will focus on using difference amplifier to reduce the common mode noise.

Difference Amplifier

Figure 5 shows a difference amplifier using an op amp. It presents an impedance of R_1 to each end of the sensor (V_1 and V_2) and amplifies the input difference voltage ($V_1 - V_2$).

An ideal difference amplifier gives an output as:

EQUATION 2:

$$V_{OUT} = G_{DM} \times (V_1 - V_2)$$

$$G_{DM} = \frac{R_2}{R_1}$$

Where:

G_{DM} = Difference Mode Gain

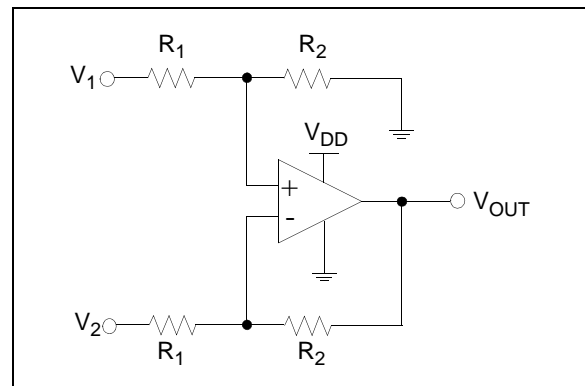

FIGURE 5: Difference Amplifier

Advantages:

- Resistive isolation from the source
- Large input voltage range is possible
- Rejects common mode noise
- Simplicity

Disadvantages:

- Resistive loading of the source
- Input stage distortion

Equation 3 gives a more practical result for the difference amplifier.

EQUATION 3:

$$V_{OUT} = G_{DM} \times (V_1 - V_2) + G_{CM} \times \left(\frac{V_1 + V_2}{2} \right)$$

$$G_{DM} = \frac{R_2}{R_1} \quad G_{CM} = \frac{G_{DM}}{CMRR_{DIFF}}$$

Where:

G_{DM}	=	Difference Mode Voltage
G_{CM}	=	Common Mode Voltage
$CMRR_{DIFF}$	=	Common Mode Rejection Ratio of Difference Amplifier

From the above equation, it can be summarized that a practical difference amplifier amplifies the difference mode voltage by G_{DM} and the common mode voltage by G_{CM} .

The $CMRR_{DIFF}$ is given by:

EQUATION 4:

$$CMRR_{DIFF} = \frac{1}{\frac{1}{CMRR_{OP}} + 2 \times TOL_R}$$

Where:

TOL_R	=	Resistors' Tolerance
$CMRR_{OP}$	=	Common Mode Rejection Ratio of Operational Amplifier

Notice that a difference amplifier with lower TOL_R and higher $CMRR_{OP}$ will have the higher $CMRR_{DIFF}$.

If the op amp's CMRR ($CMRR_{OP}$) is given in V/V (e.g., 80 dB is converted to 10,000 V/V), and the resistor tolerance (TOL_R) is given in absolute terms (e.g., 0.1% becomes 0.001), then the difference amplifier's CMRR ($CMRR_{DIFF}$) will be in V/V (for the example already given, 476 V/V = 54 dB).

Equation 3 shows that as $CMRR_{DIFF}$ increases, G_{CM} becomes smaller. For a perfectly symmetrical difference amplifier, as $CMRR_{DIFF}$ approaches infinity, G_{CM} approaches zero.

Analog Sensor Conditioning Circuit

Figure 6 shows the analog sensor conditioning circuit.

It includes three building blocks:

- Buffer Amplifier
- Difference Amplifier
- 2nd Order Low-Pass Filter

BUFFER AMPLIFIER

- MCP6001 standard op amp used as unity gain buffer
- Provides a low impedance adjustable reference voltage

EQUATION 5:

$$CV_{REF} = V_{SHIFT}$$

Where:

CV_{REF} = Selectable reference voltage of PIC18F2550

DIFFERENCE AMPLIFIER

- $V_{DD} = 5.0V$, $V_{SS} = 0V$
- Uses a MCP6V01 auto-zeroed op amp (U5)
- Two 0.1% tolerance gain resistors (R_8 and R_{11})
- Two 0.1% tolerance input resistors for shifting V_{OUT1} (R_9 and R_{10})
- Two 0.1% tolerance input resistors for the thermocouple output (R_6 and R_7)

The difference amplifier is powered in single supply configuration and V_{DD} should have a local bypass capacitor (i.e., 0.01 μF to 0.1 μF). V_{OUT1} must be kept within the ADC's allowed voltage range, which is scaled by the gain of MCP6V01. The low tolerance gain setting resistors are matched to provide symmetry for good common mode rejection.

The MCP6V01 auto-zeroed op amp less than 2 μV input offset voltage and high common-mode rejection ratio makes it ideal for thermocouple sensing applications.

The transfer function set by the difference amplifier is:

EQUATION 6:

$$V_{OUT1} = G_1 \times V_{TH} + G_2 \times (0 - V_{SHIFT}) + V_{REF}$$

$$= G_1 \times V_{TH} - G_2 \times V_{SHIFT} + V_{REF}$$

Where:

- $V_{TH} = V_P - V_M$; EMF Voltage from Thermocouple
- $V_{REF} = 4.1V$; Reference Voltage
- $V_{SHIFT} = CV_{REF}$
- $V_{OUT1} =$ Output Voltage of Difference Amplifier
- $G_1 = R_{11}/R_7 = R_8/R_6 = 1000 V/V$
- $G_2 = R_{11}/R_{10} = R_8/R_9 = 17.86 V/V$

2ND ORDER RC LOW-PASS FILTER

- Fast enough to quick changes in temperature
- Double pole for anti-aliasing and removing high-frequency noise
- No DC offset and simple architecture

The pole set by the low-pass filter is:

EQUATION 7:

$$f_P = \frac{1}{2\pi R_{12} C_6} = \frac{1}{2\pi R_{13} C_7} = 3.19Hz$$

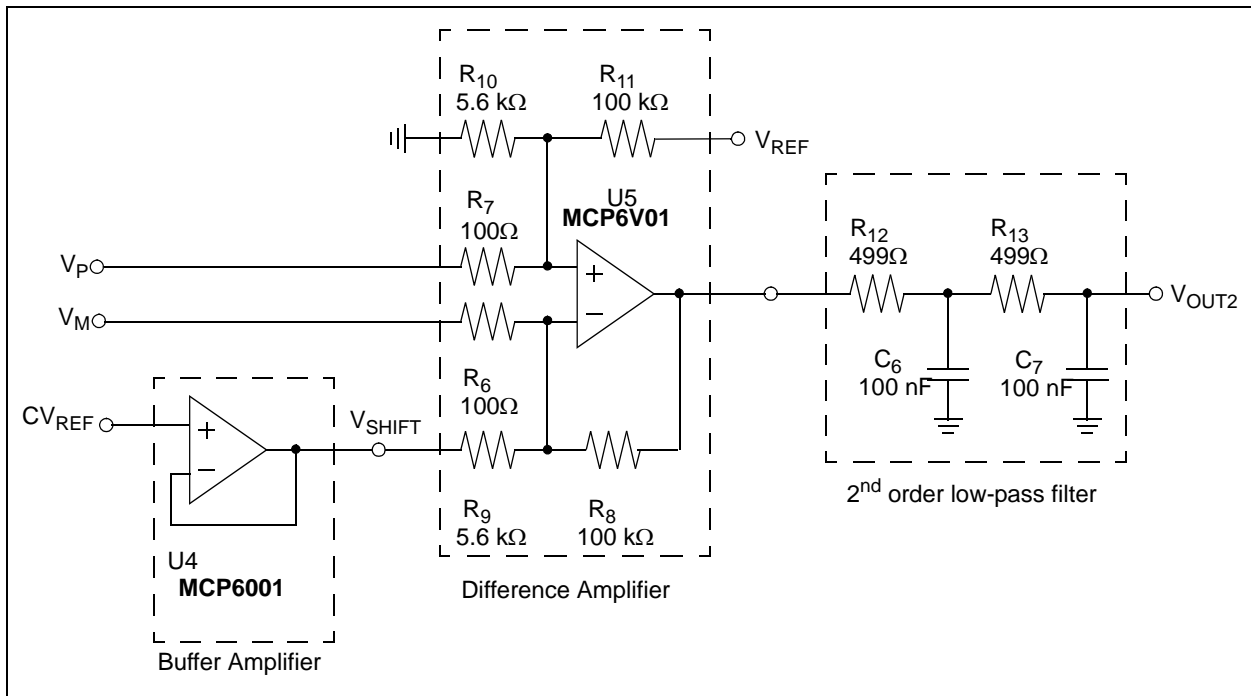

FIGURE 6: Analog Sensing Circuit Diagram.

AN1306

V_{SHIFT} Operation Description

PIC18F2550'S COMPARATOR VOLTAGE REFERENCE BLOCK DIAGRAM

The comparator voltage reference is a 16-tap resistor ladder network that provides a selectable reference voltage. Although its primary purpose is to provide a reference for the analog comparators, it may also be used independently of them. A block diagram of the module is shown in Figure 7. The resistor ladder is segmented to provide two ranges of CV_{REF} values and has a power-down function to conserve power when the reference is not being used. The module's supply reference can be provided from either device V_{DD}/V_{SS} or an external voltage reference.

In this application note, $CVRSS = 1$ is set for V_{REF+} and $CVRSS = 0$ is set for V_{REF-} . The MCP1541 provides an absolute reference voltage 4.1V. ($V_{REF+} = 4.1V$ and $V_{REF-} = 0V$).

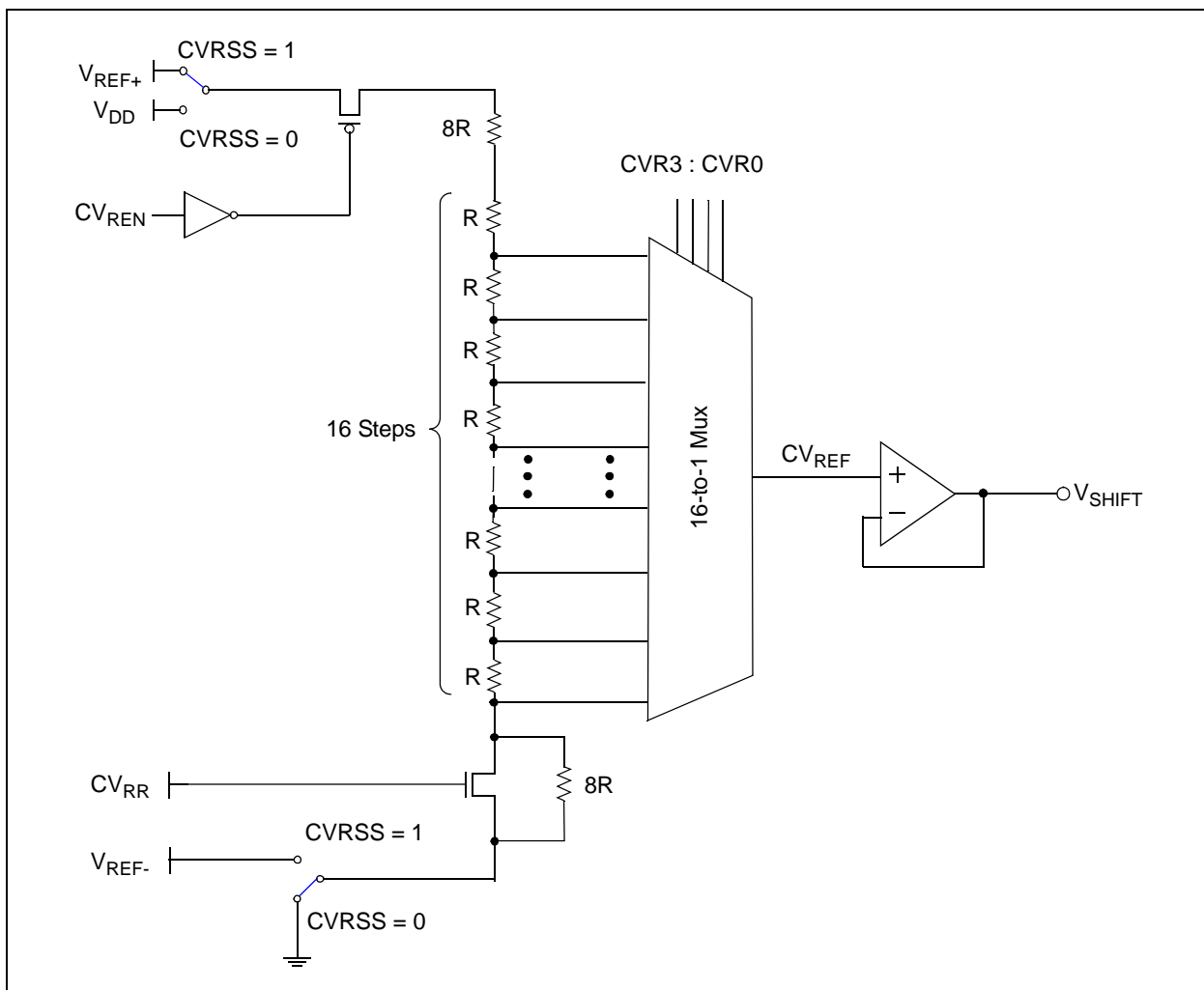

FIGURE 7: PIC18F2550 Comparator Voltage Reference Block Diagram.

V_{SHIFT} OPERATION CONCEPTUAL DIAGRAM

Figure 8 shows the V_{SHIFT} operation conceptual diagram. V_{SHIFT} is also connected to the PIC18F2550 ADC channels along with V_{OUT2}, which is used to calculate Thermocouple EMF voltage. The 10-bit ADC and the 4-bit adjustable reference voltage provide a 14-bit measurement resolution. The MCP1541 provides an absolute reference to the ADC and difference amplifier circuit.

This solution minimizes cost by using resources internal to the PIC to achieve high accuracy and high resolution thermocouple solution. This solution eliminates the need for a high end and costly instrumentation system to measure temperature using thermocouple. Further savings could be achieved by using a voltage reference internal to the PIC instead of the external MCP1541.

- 14-bit Resolution, 10-bit ADC:
 - PIC18F2550's CV_{REF} (4-bit Adjustable Reference Voltage)
 - PIC18F2550's internal 10-bit ADC
 - The firmware automatically searches for correct CV_{REF} level

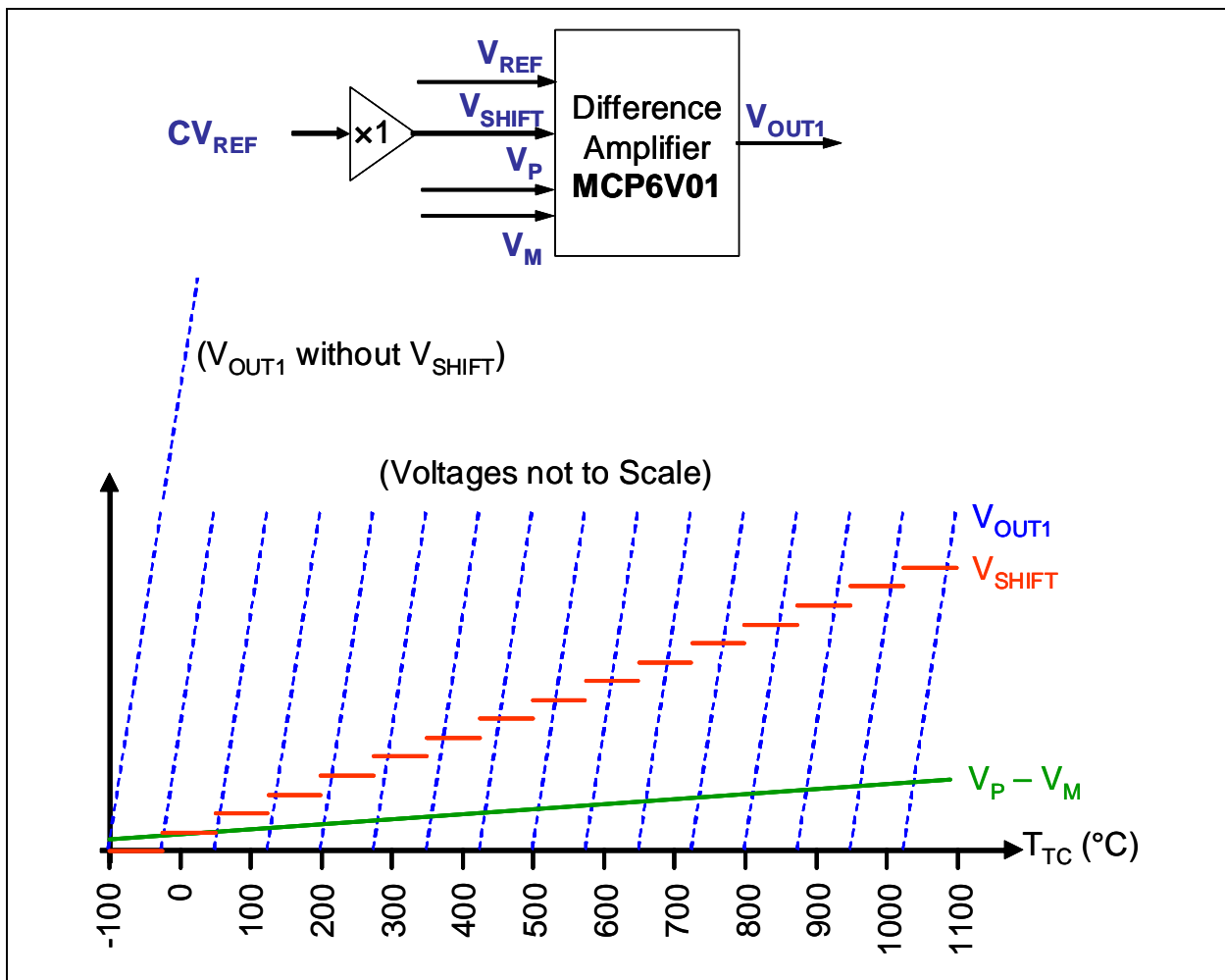

FIGURE 8: V_{SHIFT} Operation Conceptual Diagram.

AN1306

Automatic Reference Voltage Search

Figure 9 shows a screen capture from an oscilloscope while the PIC18F2550 searches a reference voltage V_{SHIFT} . Channel 1 (yellow trace) is the MCP6V01 output V_{OUT1} and Channel 2 is V_{SHIFT} . V_{SHIFT} is adjusted until the output is scaled within a voltage range of 0.2V to 4V, as shown in Table 1. The search is

sequenced by first setting CV_{REF} levels 0, 15, 1, 14, 2, 13, ... 6, 9, and 7. The voltage at level 7 set the output to equal approximately 0.7V. Then, EMF is calculated by measuring V_{SHIFT} and V_{OUT2} .

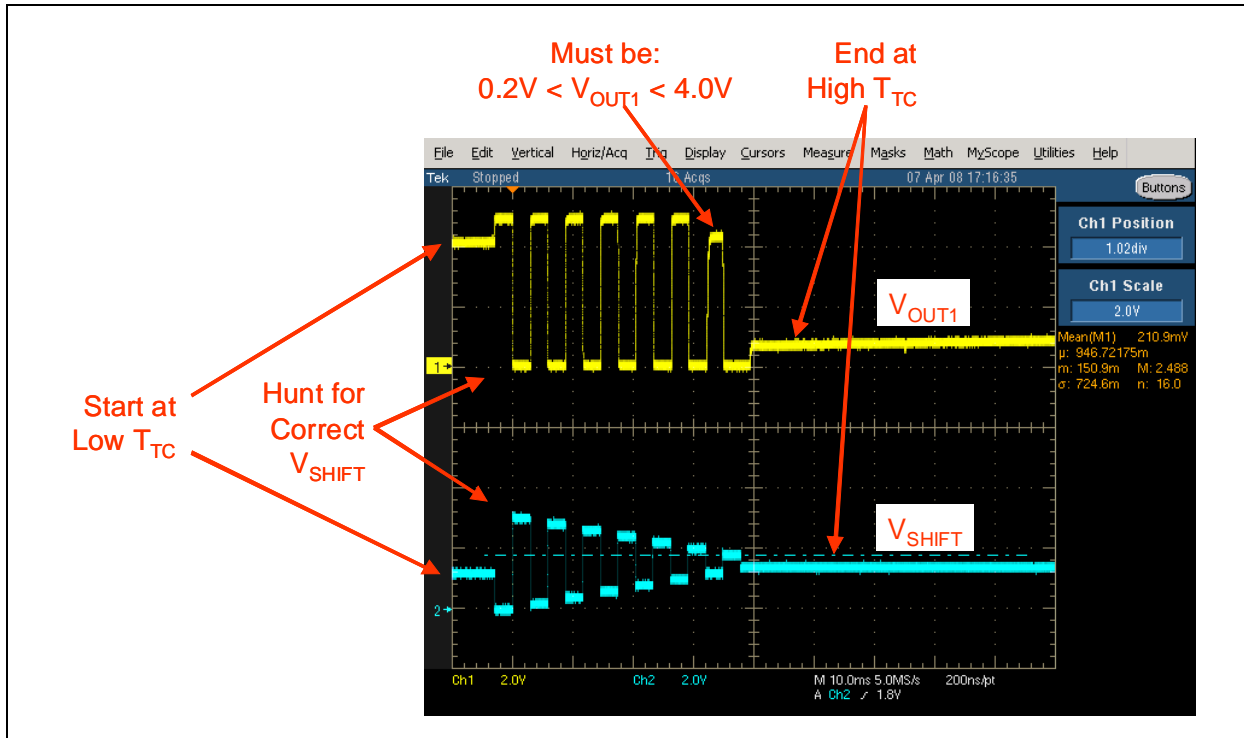

FIGURE 9: Voltage vs. Time Plot

TABLE 1: V_{SHIFT} OPERATION CHANGING POINTS

# Ref	Approximate V_{SHIFT}	ADC (Code)	V_{OUT1} (V)	V_{TH} (mV)	Approximate Temp Range ($^{\circ}$ C)
0	0	50 to 1000	0.200 to 4.000	-3.900 to -0.096	-102 to +2
1	0.208333	50 to 1000	0.200 to 4.000	-0.180 to 3.624	-4 to +88
2	0.416667	50 to 1000	0.200 to 4.000	3.541 to 7.344	+86 to +180
3	0.625000	50 to 1000	0.200 to 4.000	7.261 to 11.065	+178 to +272
4	0.833333	50 to 1000	0.200 to 4.000	10.981 to 14.785	+270 to +361
5	1.041667	50 to 1000	0.200 to 4.000	14.701 to 18.505	+359 to +449
6	1.250000	50 to 1000	0.200 to 4.000	18.422 to 22.225	+447 to +537
7	1.458333	50 to 1000	0.200 to 4.000	22.142 to 25.946	+535 to +624
8	1.666667	50 to 1000	0.200 to 4.000	25.862 to 29.666	+622 to +712
9	1.875000	50 to 1000	0.200 to 4.000	29.582 to 33.386	+710 to +802
10	2.083333	50 to 1000	0.200 to 4.000	33.303 to 37.106	+800 to +894
11	2.291667	50 to 1000	0.200 to 4.000	37.023 to 40.827	+892 to +988
12	2.500000	50 to 1000	0.200 to 4.000	40.743 to 44.547	+986 to +1083
13	2.708333	50 to 1000	0.200 to 4.000	44.463 to 48.267	+1081 to +1184
14	2.916667	50 to 1000	0.200 to 4.000	48.184 to 51.987	+1182 to +1277
15	3.125000	50 to 1000	0.200 to 4.000	51.904 to 55.707	+1275 to +1372

FIRMWARE AND SOFTWARE

Firmware

The firmware uses the PIC18F2550 USB PIC[®] Microcontroller to compute Thermocouple temperature and transfer temperature data to PC via the USB interface. The firmware has two major functions, maintain USB interface with PC and measure/compute temperature.

The firmware uses USB HID interface and does not require PC side driver software. Once the USB is connected to a PC the USB module is initialized, and the Thermocouple temperature conversion is started upon a successful USB initialization.

The Thermocouple measurement routine starts by measuring the thermocouple output voltage from the MCP6V01. If the output voltage is out of range as shown in the [Table 1](#) then the reference voltage is adjusted automatically as shown in [Figure 9](#). Once the corresponding V_{SHIFT} value is determined, both V_{OUT2} and V_{SHIFT} are digitized using the 10bit ADC. From these voltages, the Thermocouple EMF is calculated. The EMF voltage is converted to temperature in degree Celcius (°C) using the 9th order equation provided by ITS-90 standard (www.nist.org). The temperature value is cold-junction compensated using the MCP9800 temperature sensor.

EQUATION 8: EMF CALCULATION

$$EMF = (V_{OUT2} + V_{SHIFT} \cdot Gain - V_{REF})$$

Where:

- EMF = Thermocouple voltage (mV)
- V_{OUT2} = MCP6V01 Filtered Output (V)
- V_{SHIFT} = Adjustable reference voltage (V)
- Gain = Difference Amplifier Gain (R8/R9)
- V_{REF} = Absolute reference voltage, MCP1541 output (V)

EQUATION 9: COLD JUNCTION COMPENSATION

$$T = T_{CJ} - T_{HJ}$$

Where:

- T = Absolute Thermocouple temperature (°C)
- T_{CJ} = Cold-Junction temperature, MCP9800 output (°C)
- T_{HJ} = Hot-Junction temperature or Thermocouple temperature from ITS-90 standard (°C)

The temperature data is stored in memory in IEEE Standard for Floating-Point Arithmetic (IEEE 754). When a temperature data is requested from the PC the floating point data is converted to Binary Code Decimal (BCD) and each byte is loaded in the USB data transfer buffer. Along with the temperature data, V_{OUT2} , V_{SHIFT} and the cold-junction temperature are loaded. The PC Graphical User Interface (GUI) converts the BCD data to floating point number which represents temperature. The temperature data is displayed and plotted on the graphical display. Additionally, the GUI displays EMF voltage, thermocouple output and cold junction temperature.

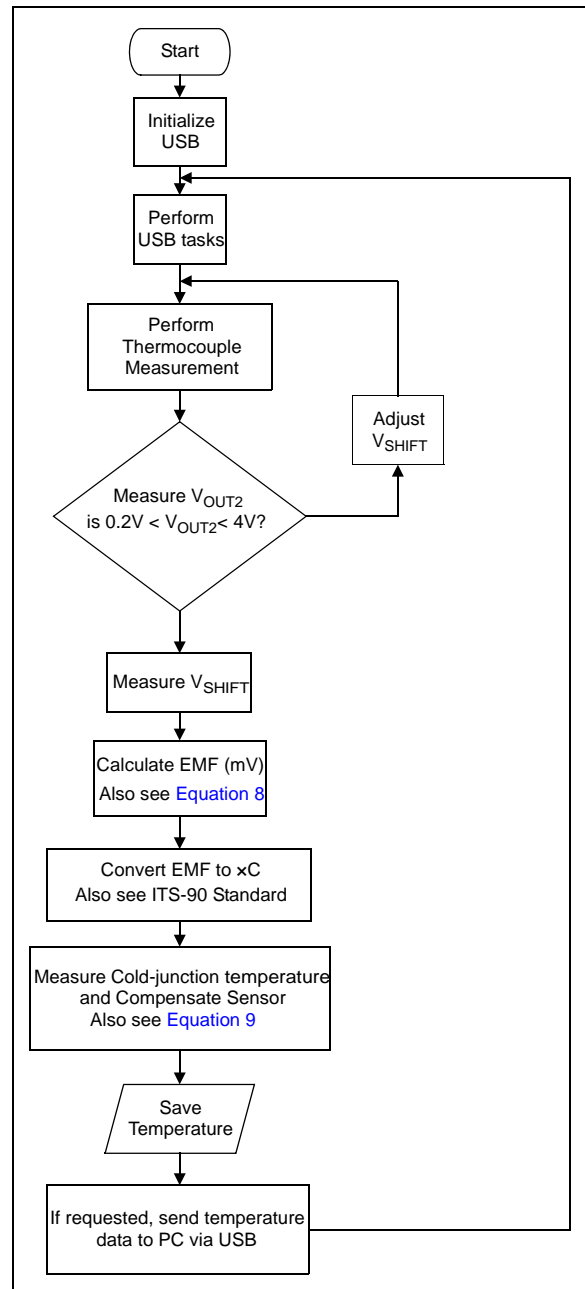

FIGURE 10: Top Level Flow Chart.

AN1306

Thermal Management Software GUI

The GUI is a measurement tool which enables user to see the changes in temperature graphically by displaying the Thermocouple raw output data along with linearized temperature data. It also enables user to calibrate the system.

Temperature can also be measured over an extended period of time by clicking the **Start Acquisition** button or **Play** button. The measurement interval is controlled by the software timer. When the timer ticks a command is sent to the hardware to acquire temperature data then the firmware transfers the last successfully converted temperature data.

Additionally, user can calibrate the Thermocouple sensor by using the calibration option from the GUI. This feature can be enabled by clicking on the Enable Calibration check box. Once enabled, user can type in the thermocouple calibration temperature and click the **Calibrate!** button. When calibrated, the temperature difference between the thermocouple and calibration temperature is stored in the PICmicro EEPROM. The difference is also shown in the "Calibration Offset" display of the GUI. Once calibrated, the offset is subtracted from temperature measurements. In addition, clicking the **Reset** button clears the calibration offset value to 0 (the EEPROM content is set to 0).

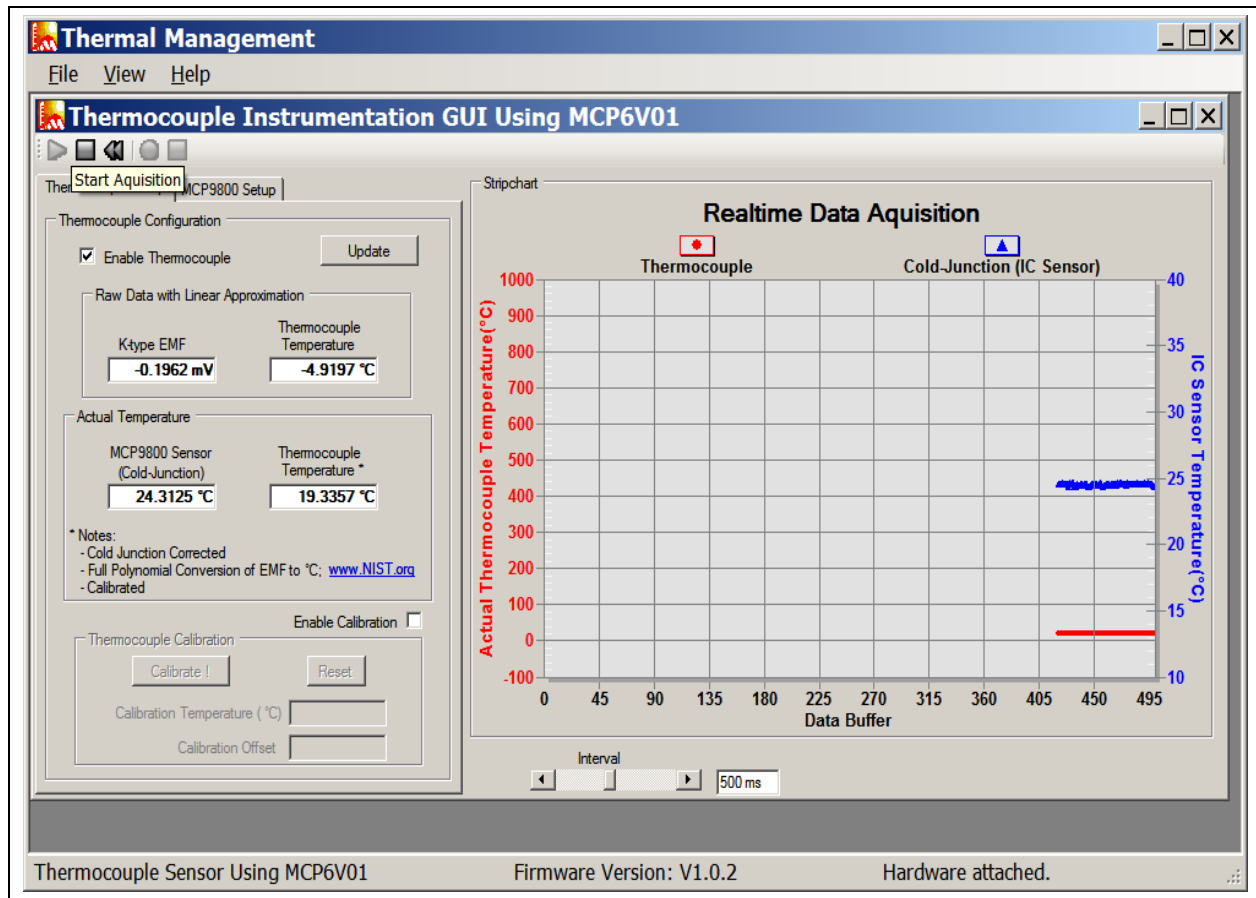

FIGURE 11: Graphical User Interface.

SUMMARY

This application note shows hardware and firmware design engineers how to use a PICmicro[®] Microcontroller and a difference amplifier system to measure Type-K Thermocouple voltage to accurately measure temperature from -100°C to 1000°C using a 10-bit ADC and 4-bit adjustable reference voltage.

REFERENCES

- [1] *"The OMEGA[®] Made in the USA Handbook[™]",* Vol. 1, OMEGA Engineering, Inc., ©2002.
- [2] *"The OMEGA[®] Made in the USA Handbook[™]",* Vol. 2, OMEGA Engineering, Inc., ©2002.
- [3] AN990, *"Analog Sensor Conditioning Circuits – An Overview",* Kumen Blake, Microchip Technology Inc., DS00990, ©2005.
- [4] AN1258, *"Op Amp Precision Design: PCB Layout Techniques",* Kumen Blake, Microchip Technology Inc., DS01258, ©2009.
- [5] AN679, *"Temperature Sensing Technologies",* Bonnie Baker, Microchip Technology Inc., DS00679, ©1998.
- [6] AN684, *"Single Supply Temperature Sensing with Thermocouples",* Bonnie Baker, Microchip Technology Inc., DS00684, 1998.
- [7] MCP6V01/2/3 Data Sheet, *"Auto-Zeroed Op Amps",* Microchip Technology Inc., DS22058, ©2008.
- [8] PIC18F2455/2550/4455/4550 Data Sheet, *"28/40/44-Pin, High-Performance, Enhanced Flash, USB Microcontrollers with nanoWatt Technology",* Microchip Technology Inc., DS39632, ©2007.
- [9] *"MCP6V01 Thermocouple Auto-Zeroed Reference Design",* Yang Zhen, Microchip Technology Inc., DS51738, ©2008.
- [10] AN1297, *"Microchip's Op Amp SPICE Macro Models",* Yang Zhen, Microchip Technology Inc. DS01297, ©2009.

AN1306

NOTES:

Note the following details of the code protection feature on Microchip devices:

- Microchip products meet the specification contained in their particular Microchip Data Sheet.
- Microchip believes that its family of products is one of the most secure families of its kind on the market today, when used in the intended manner and under normal conditions.
- There are dishonest and possibly illegal methods used to breach the code protection feature. All of these methods, to our knowledge, require using the Microchip products in a manner outside the operating specifications contained in Microchip's Data Sheets. Most likely, the person doing so is engaged in theft of intellectual property.
- Microchip is willing to work with the customer who is concerned about the integrity of their code.
- Neither Microchip nor any other semiconductor manufacturer can guarantee the security of their code. Code protection does not mean that we are guaranteeing the product as “unbreakable.”

Code protection is constantly evolving. We at Microchip are committed to continuously improving the code protection features of our products. Attempts to break Microchip's code protection feature may be a violation of the Digital Millennium Copyright Act. If such acts allow unauthorized access to your software or other copyrighted work, you may have a right to sue for relief under that Act.

Information contained in this publication regarding device applications and the like is provided only for your convenience and may be superseded by updates. It is your responsibility to ensure that your application meets with your specifications. MICROCHIP MAKES NO REPRESENTATIONS OR WARRANTIES OF ANY KIND WHETHER EXPRESS OR IMPLIED, WRITTEN OR ORAL, STATUTORY OR OTHERWISE, RELATED TO THE INFORMATION, INCLUDING BUT NOT LIMITED TO ITS CONDITION, QUALITY, PERFORMANCE, MERCHANTABILITY OR FITNESS FOR PURPOSE. Microchip disclaims all liability arising from this information and its use. Use of Microchip devices in life support and/or safety applications is entirely at the buyer's risk, and the buyer agrees to defend, indemnify and hold harmless Microchip from any and all damages, claims, suits, or expenses resulting from such use. No licenses are conveyed, implicitly or otherwise, under any Microchip intellectual property rights.

Trademarks

The Microchip name and logo, the Microchip logo, dsPIC, KEELOQ, KEELOQ logo, MPLAB, PIC, PICmicro, PICSTART, rPIC and UNI/O are registered trademarks of Microchip Technology Incorporated in the U.S.A. and other countries.

FilterLab, Hampshire, HI-TECH C, Linear Active Thermistor, MXDEV, MXLAB, SEEVAL and The Embedded Control Solutions Company are registered trademarks of Microchip Technology Incorporated in the U.S.A.

Analog-for-the-Digital Age, Application Maestro, CodeGuard, dsPICDEM, dsPICDEM.net, dsPICworks, dsSPEAK, ECAN, ECONOMONITOR, FanSense, HI-TIDE, In-Circuit Serial Programming, ICSP, Mindi, MiWi, MPASM, MPLAB Certified logo, MPLIB, MPLINK, mTouch, Octopus, Omniscient Code Generation, PICC, PICC-18, PICDEM, PICDEM.net, PICkit, PICtail, PIC³² logo, REAL ICE, rLAB, Select Mode, Total Endurance, TSHARC, UniWinDriver, WiperLock and ZENA are trademarks of Microchip Technology Incorporated in the U.S.A. and other countries.

SQTP is a service mark of Microchip Technology Incorporated in the U.S.A.

All other trademarks mentioned herein are property of their respective companies.

© 2009, Microchip Technology Incorporated, Printed in the U.S.A., All Rights Reserved.

 Printed on recycled paper.

QUALITY MANAGEMENT SYSTEM
CERTIFIED BY DNV
== ISO/TS 16949:2002 ==

Microchip received ISO/TS-16949:2002 certification for its worldwide headquarters, design and wafer fabrication facilities in Chandler and Tempe, Arizona; Gresham, Oregon and design centers in California and India. The Company's quality system processes and procedures are for its PIC[®] MCUs and dsPIC[®] DSCs, KEELOQ[®] code hopping devices, Serial EEPROMs, microperipherals, nonvolatile memory and analog products. In addition, Microchip's quality system for the design and manufacture of development systems is ISO 9001:2000 certified.



WORLDWIDE SALES AND SERVICE

AMERICAS

Corporate Office

2355 West Chandler Blvd.
Chandler, AZ 85224-6199
Tel: 480-792-7200
Fax: 480-792-7277
Technical Support:
<http://support.microchip.com>
Web Address:
www.microchip.com

Atlanta

Duluth, GA
Tel: 678-957-9614
Fax: 678-957-1455

Boston

Westborough, MA
Tel: 774-760-0087
Fax: 774-760-0088

Chicago

Itasca, IL
Tel: 630-285-0071
Fax: 630-285-0075

Cleveland

Independence, OH
Tel: 216-447-0464
Fax: 216-447-0643

Dallas

Addison, TX
Tel: 972-818-7423
Fax: 972-818-2924

Detroit

Farmington Hills, MI
Tel: 248-538-2250
Fax: 248-538-2260

Kokomo

Kokomo, IN
Tel: 765-864-8360
Fax: 765-864-8387

Los Angeles

Mission Viejo, CA
Tel: 949-462-9523
Fax: 949-462-9608

Santa Clara

Santa Clara, CA
Tel: 408-961-6444
Fax: 408-961-6445

Toronto

Mississauga, Ontario,
Canada
Tel: 905-673-0699
Fax: 905-673-6509

ASIA/PACIFIC

Asia Pacific Office

Suites 3707-14, 37th Floor
Tower 6, The Gateway
Harbour City, Kowloon
Hong Kong
Tel: 852-2401-1200
Fax: 852-2401-3431

Australia - Sydney

Tel: 61-2-9868-6733
Fax: 61-2-9868-6755

China - Beijing

Tel: 86-10-8528-2100
Fax: 86-10-8528-2104

China - Chengdu

Tel: 86-28-8665-5511
Fax: 86-28-8665-7889

China - Hong Kong SAR

Tel: 852-2401-1200
Fax: 852-2401-3431

China - Nanjing

Tel: 86-25-8473-2460
Fax: 86-25-8473-2470

China - Qingdao

Tel: 86-532-8502-7355
Fax: 86-532-8502-7205

China - Shanghai

Tel: 86-21-5407-5533
Fax: 86-21-5407-5066

China - Shenyang

Tel: 86-24-2334-2829
Fax: 86-24-2334-2393

China - Shenzhen

Tel: 86-755-8203-2660
Fax: 86-755-8203-1760

China - Wuhan

Tel: 86-27-5980-5300
Fax: 86-27-5980-5118

China - Xiamen

Tel: 86-592-2388138
Fax: 86-592-2388130

China - Xian

Tel: 86-29-8833-7252
Fax: 86-29-8833-7256

China - Zhuhai

Tel: 86-756-3210040
Fax: 86-756-3210049

ASIA/PACIFIC

India - Bangalore

Tel: 91-80-3090-4444
Fax: 91-80-3090-4080

India - New Delhi

Tel: 91-11-4160-8631
Fax: 91-11-4160-8632

India - Pune

Tel: 91-20-2566-1512
Fax: 91-20-2566-1513

Japan - Yokohama

Tel: 81-45-471- 6166
Fax: 81-45-471-6122

Korea - Daegu

Tel: 82-53-744-4301
Fax: 82-53-744-4302

Korea - Seoul

Tel: 82-2-554-7200
Fax: 82-2-558-5932 or
82-2-558-5934

Malaysia - Kuala Lumpur

Tel: 60-3-6201-9857
Fax: 60-3-6201-9859

Malaysia - Penang

Tel: 60-4-227-8870
Fax: 60-4-227-4068

Philippines - Manila

Tel: 63-2-634-9065
Fax: 63-2-634-9069

Singapore

Tel: 65-6334-8870
Fax: 65-6334-8850

Taiwan - Hsin Chu

Tel: 886-3-6578-300
Fax: 886-3-6578-370

Taiwan - Kaohsiung

Tel: 886-7-536-4818
Fax: 886-7-536-4803

Taiwan - Taipei

Tel: 886-2-2500-6610
Fax: 886-2-2508-0102

Thailand - Bangkok

Tel: 66-2-694-1351
Fax: 66-2-694-1350

EUROPE

Austria - Wels

Tel: 43-7242-2244-39
Fax: 43-7242-2244-393

Denmark - Copenhagen

Tel: 45-4450-2828
Fax: 45-4485-2829

France - Paris

Tel: 33-1-69-53-63-20
Fax: 33-1-69-30-90-79

Germany - Munich

Tel: 49-89-627-144-0
Fax: 49-89-627-144-44

Italy - Milan

Tel: 39-0331-742611
Fax: 39-0331-466781

Netherlands - Drunen

Tel: 31-416-690399
Fax: 31-416-690340

Spain - Madrid

Tel: 34-91-708-08-90
Fax: 34-91-708-08-91

UK - Wokingham

Tel: 44-118-921-5869
Fax: 44-118-921-5820

03/26/09