



Service Manual

Washing machine

Toploader

AWT 2289

Model Version		Page
AWT 2289 8561 228 10190		
	Technical data	2 - 3
	Spare part list	4
	Exploded view	5 - 6
	Wiring diagram	7
	Circuit diagram	8
	Program diagram	9

Technical data**Dimensions**

Height	85.0	cm
Width	40.0	cm
Depth	60.0	cm

Weight

Net weight	61	kg
With packing	64	kg

Main connection

Voltage	230	V ± 10%
Frequency	50	Hz
Power consumption	~ 2.3	kW
Fuse rating	10	A

Drum

Volume	42	l
Wash spin	54	rpm
Speed spinning max.	500/ 800	rpm

Capacity of dry laundry

Cotton/coloured laundry	5/ 4.5	kg
Cotton rapid	3	kg
Easy care	2.5	kg
Easy care rapid	1.5	kg
Delicate	1.5	kg
Wool	1	kg

Pressostat for washing-machine**Level 0 - PRF - anti foam**

Switching point	35 ± 5	mm Wc
Reset	15 ± 5	mm Wc

Level 1 - PRL - washing

Switching point	65 ± 5	mm Wc
Reset	35 ± 5	mm Wc
Overflow - PRS		
Switching point	300 ± 20	mm Wc

Water column drum**Level 1 - PRL - washing**

Switching point	50 ± 5	mmWc
Overflow		
Switching point	285 ± 20	mmWc

Nominal current**Contacts:**

11 - 12	0.5 - 1 mA/ 5 V DC
11 - 14	0.5 - 1 mA/ 5 V DC
21 - 12	4 (4) A
21 - 24	16 (4) A
21 - 26	1 (1) A

Contacts system:

11 - 12 - 14	jump contacts
21 - 22 - 24	jump contacts
21 - 26	slow action contacts

Door lock

Lock time (0 - 85 °C)	< 5"
Unlock time after 30" on	110" ± 50"
Nominal voltage	250 V
Nominal current contacts:	
4 - 5	16 (4) A

Heating element

Kind of heating	Tubular heating element
Nominal voltage	230 V
Nominal power	2050 W
Heat conductor resistance	25.8 Ω ± 5%
Working temperature max.	120 °C

Water inlet valve

Water temperature max.	90 °C
Rated flow (> 1 bar)	8 l/min.
Pressure range	0.2 - 10 bar
Nominal voltage	220 - 240 V
Frequency	50 Hz
Starting voltage	170 V
Nominal current	40 mA
Nominal power	8.8 VA
Nominal resistor(20°C)	3.8 kΩ ± 10%

Drain pump (synchronous)

Nominal voltage	230 V
Nominal current	0.3 A
Nominal consumption	34 W
Frequency	50 Hz
Resistor (coil)	164 Ω ± 7%
Motor protection	no
Capacity (1.25m height)	14 l/min

Technical data

Program timer

Type	Electromechanical	
Fab.	EC 4774 (Timer A2-)	
Nominal voltage	230	V
Frequency	50	Hz
Total positions	60	
Pre wash	pos.	01
Main wash	pos.	06
Rinse	pos.	21
Spin	pos.	33/ 58
Stop	pos.	37/ 60
Ambient temperature to	70	°C
Storage temperature to	85	°C

Motor

Type	MCA 30/64 - 148/ALA 1 i = 1 : 17.3	
Pulley diameter	16.5	mm
Contact 6 - 7	68.7	$\Omega \pm 7\%$
Collector directly 4 - 5	3.07	$\Omega \pm 7\%$
Field winding 2 - 3	2.40	$\Omega \pm 7\%$
Tacho (at 825 rpm on motor)	1 - 2	V
Tacho pole pairs	16	
Protector, current sensit.	150	°C
Sense of rotation in spin., in view on pulley side	clockwise	

Radio interference supression

Nominal voltage	230	V
Nominal capacity	470 nFX1 + 2 x 22 nFY	
Nominal inductance	2 x 0.5	mH
Nominal resistance	680	k Ω

Thermostats - optional

Thermostat Bi-metal 60°C

ON	40 ± 4	°C
OFF	55 ± 3	°C
Rated voltage	230	V
Rated current	10	A

Thermostat variable

Nominal voltage	230	V
Nominal current	10	A
Temperature range	28± 4 - 80± 3 °C	

Switch mains

Push button on/off	SM
--------------------	----

Push button switch

Eco	SEC
Half load	SHL
Rinse hold	SRS
Bi speed	SSR

Motor electronic 800 rpm

Type	RN 2239
------	---------

Spare part list

Model AWT 2289
Service No. 856122810190
Version 856122810190

Pos. No.	12NC Code	Description
002 0	4812 459 38027	Flap round
002 1	4812 459 38028	Hinge Flap
004 0	4812 440 19625	Drip tray assy
010 0	4812 459 48056	Door frame inner
010 1	4812 459 48057	Door frame outer
011 0	4812 462 48054	Foot
012 7	4812 310 18497	Trolley kit front
012 8	4812 528 78046	Foot adjustable rear
021 0	4812 440 19626	Front,panel
022 0	4812 440 19628	Side panel right
022 1	4812 440 19629	Side panel left
024 0	4812 440 19631	Rear panel
025 0	4812 440 19632	Support
040 0	4812 417 18815	Hinge bolt
061 0	4812 466 88489	Counter weight
061 1	4812 466 88491	Counter weight front
061 2	4812 466 88492	Counter weight bottom
081 4	4812 529 18043	Shock absorber
086 2	4812 401 18412	Stopper
086 3	4812 529 18044	Clamp absorber
086 4	4812 529 18045	Pin f. Shock absorber
086 5	4812 529 18046	Shaft f. absorber
100 1	4812 440 19634	Lid outer
100 3	4812 440 19635	Lid inner
100 5	4812 440 19636	Lid assembly
110 4	4812 440 19553	Handle cpl.
130 0	4812 417 18849	Hook f. Door
191 0	4812 466 68596	Door bellow
191 1	4812 492 98014	Strap f. bellow
200 0	4812 418 18242	Tub 4fix points
201 0	4812 440 19644	Cover cpl.
220 0	4812 418 18243	Drum
223 0	4819 418 49713	Drum lifter
271 0	4812 358 18167	Belt Poly V 1204 H8 MA
272 0	4812 528 88083	Pulley 298 mm
290 0	4812 532 68078	Gasket
301 0	4812 452 10811	Control panel AWT 2289
331 0	4812 412 58818	Knob Timer
331 1	4812 412 58817	Knob Options
332 0	4812 410 28583	Button Options
333 0	4812 410 28611	Button on/off
339 0	4812 412 58866	Adapter
351 0	4812 124 98001	Lamp mains
351 1	4812 124 18001	Cover pilot lamp
400 0	4812 361 58146	Motor AC
421 0	4812 121 18142	Interf.filter 1,00 µ F
421 1	4812 121 18197	Cover interf.filter
430 0	4812 360 18472	Pump,draining
451 0	4812 259 28703	Heating element with hole
490 0	4812 321 18066	Cable,mains EU/2m
490 1	4812 321 28367	Strain relief
500 0	4812 282 18856	Timer EC4774
521 0	4812 214 78455	Control unit RN2239 A2-
552 0	4812 282 48235	Thermostat monopack 60 °C
554 0	4812 282 48234	Thermostat variable

Pos. No.	12NC Code	Description
571 0	4812 281 28393	Valve,magnet
571 1	4812 281 18049	Cover f. valve
581 0	4812 271 28396	Pressostat
620 0	4819 410 29005	Switch Options NC
620 2	4812 276 28369	Switch options CO
620 4	4812 276 18266	Switch Speed Reduction
621 0	4812 276 18276	Switch ON/OFF
630 0	4812 271 38373	Door lock hybrid
701 0	4819 530 29034	Hose, inlet
702 2	4812 530 28871	Hose VALVE-DISPENSER
707 0	4812 526 48044	Nozzle box cold cpl.
707 1	4812 526 48049	Clamp f. nozzle box
712 6	4812 418 68164	Clip SOAP DISPENSER
712 9	4812 418 68186	Soap dispenser cpl. 4
717 0	4812 323 18179	Cam A1/A2
717 1	4812 323 18183	Lever ass.plastic
717 2	4812 323 18021	Lever adjustment (metal)
717 3	4812 323 18181	Lever adjustment
717 4	4812 323 18182	Lever
717 5	4812 323 18025	Support lever metal
753 0	4812 418 68187	Chamber,air
754 0	4812 530 28938	Drainhose
754 1	4812 530 28832	Lock eco
760 0	4812 480 58089	Filter set pump
781 0	4812 530 28953	Hose,draining
782 0	4812 530 28941	Hose Pressostat
787 0	4812 530 28942	Hose Air Exhaust
787 1	4812 530 28943	Hose Cover
794 0	4812 530 58098	Gasket Airtrap
900 0	4812 290 68157	Strap SNP 8
900 1	4812 401 18431	Clamp to pump
900 2	4812 401 18461	Support cable/hose
900 3	4819 401 18529	Clamp,hose
900 4	4819 401 18362	Strap SNP 8
901 0	4812 401 18462	Clamp,hose drain hose
910 0	4812 502 48347	Screw,selftap 3,5x14SS
910 1	4812 502 38151	Screw 4x14
910 3	4812 502 18404	Screw
910 4	4812 502 18423	Screw PT 7x15
910 5	4812 502 18401	Screw M8X 35
910 6	4812 502 18399	Nut Push in M 8
921 0	4812 400 18047	Washer
930 1	4812 492 48171	Torsions spring
930 2	4812 492 48162	Spring
930 3	4812 323 18019	Spring f. lever
941 0	4812 310 18578	Bearing Kit
953 0	4812 325 68001	Shaft seal
962 0	4812 440 19645	Cover f. Motor
990 0	4812 310 18504	Fixing mat.set front counter
990 2	4812 310 18506	Fixing mat.set bottom
993 0	4819 530 29028	Bow
993 1	4812 290 18025	Clamp heating element

Exploded view

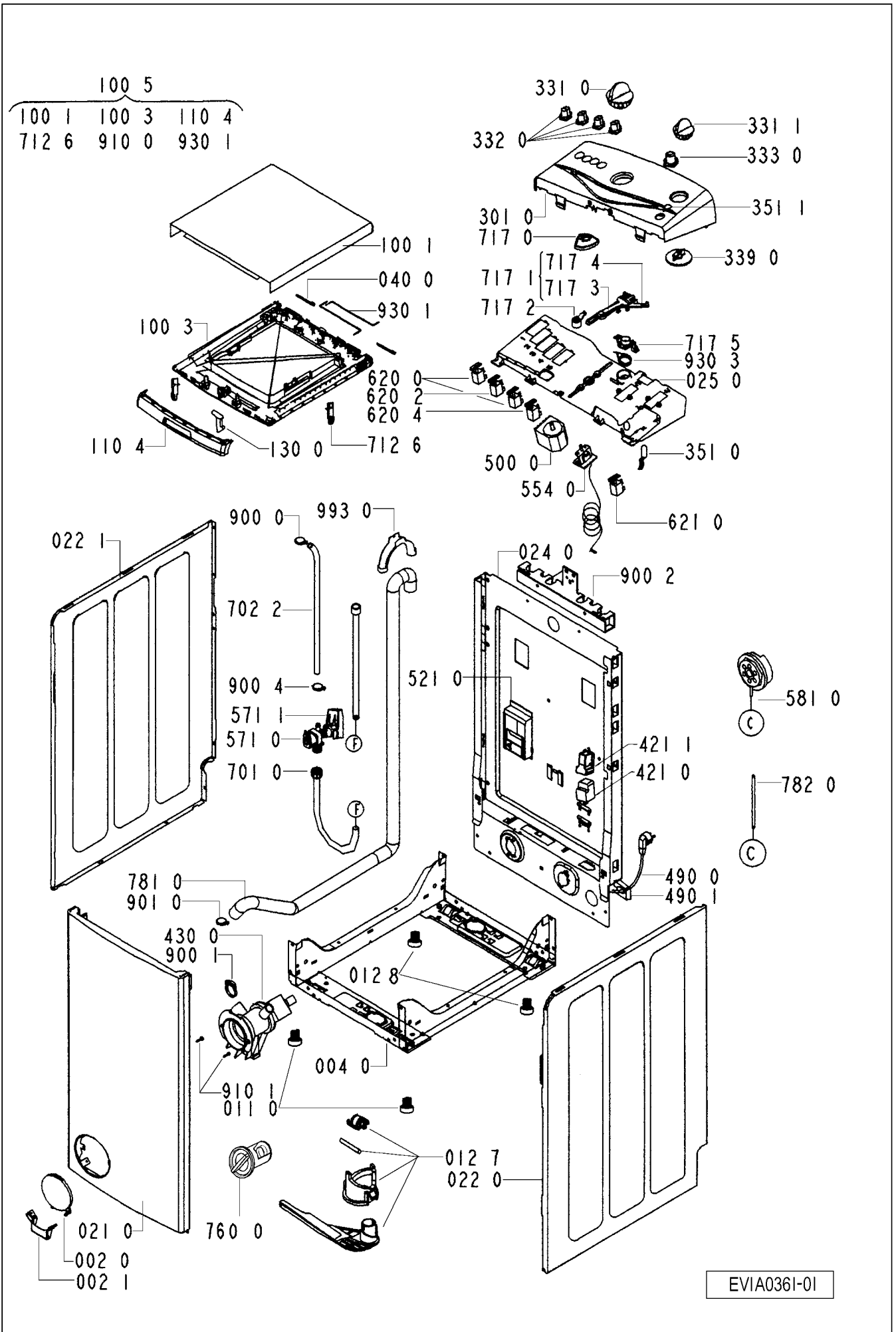

Exploded view

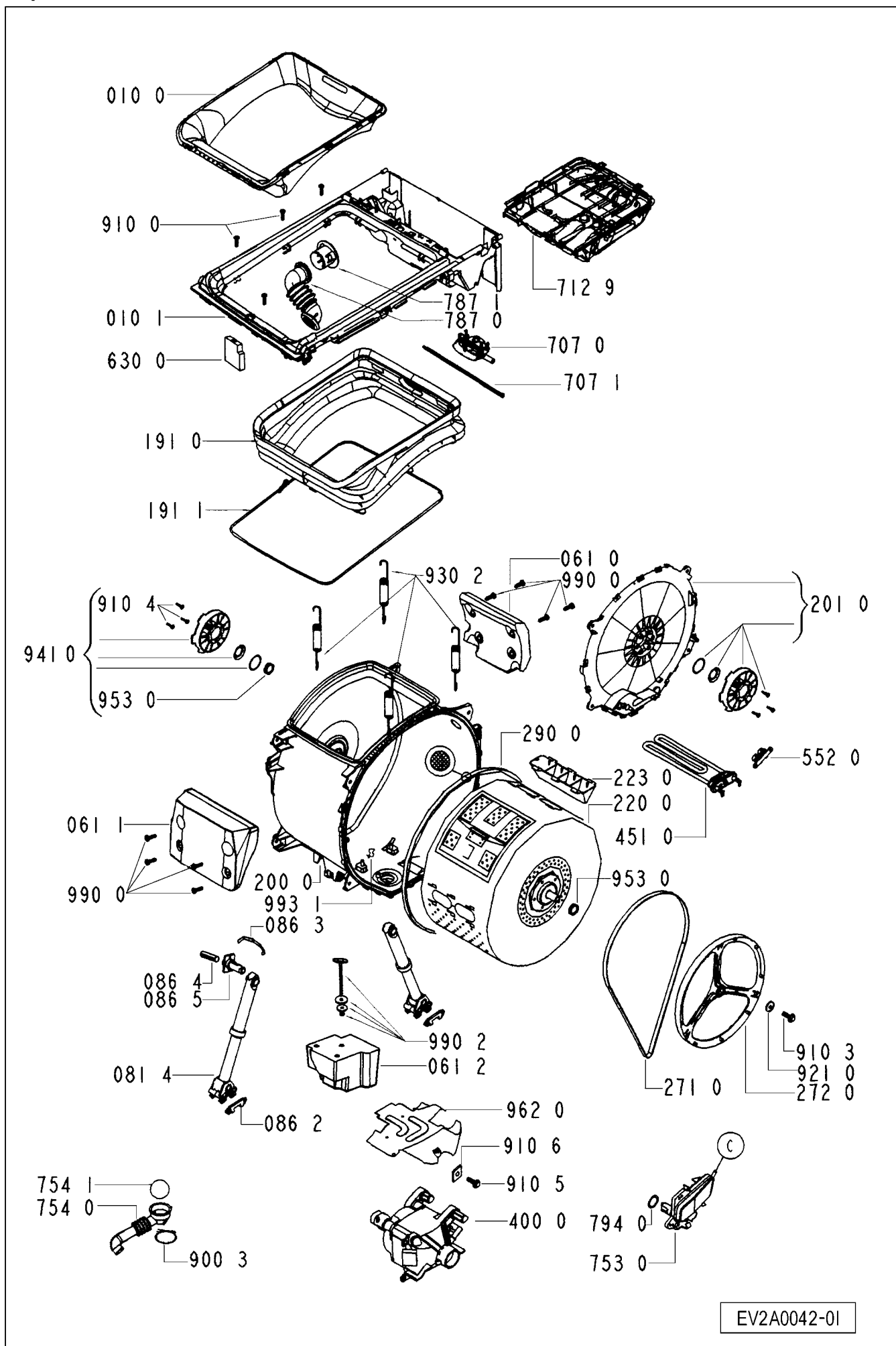

EV2A0042-01

Wiring diagram

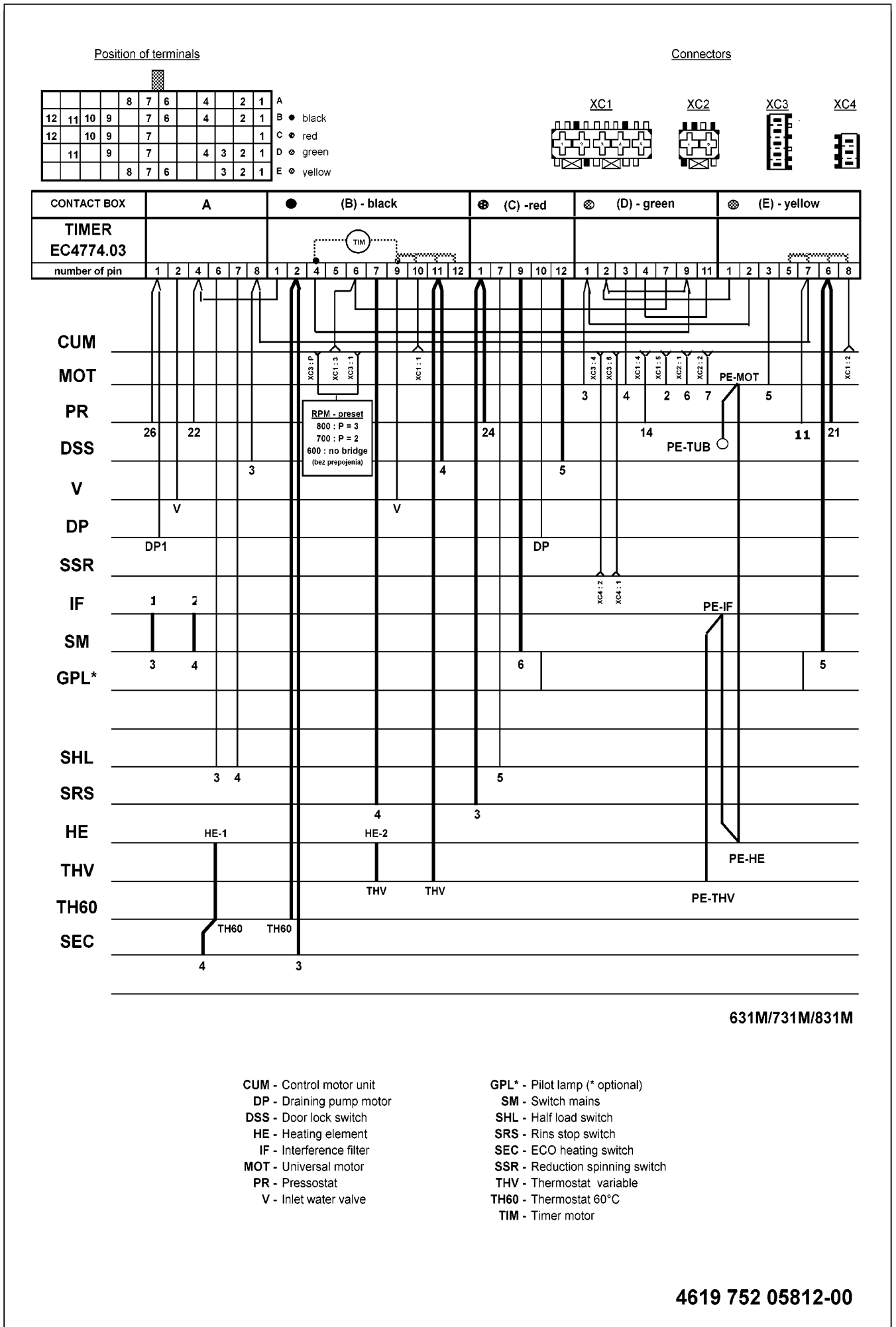

Circuit diagram

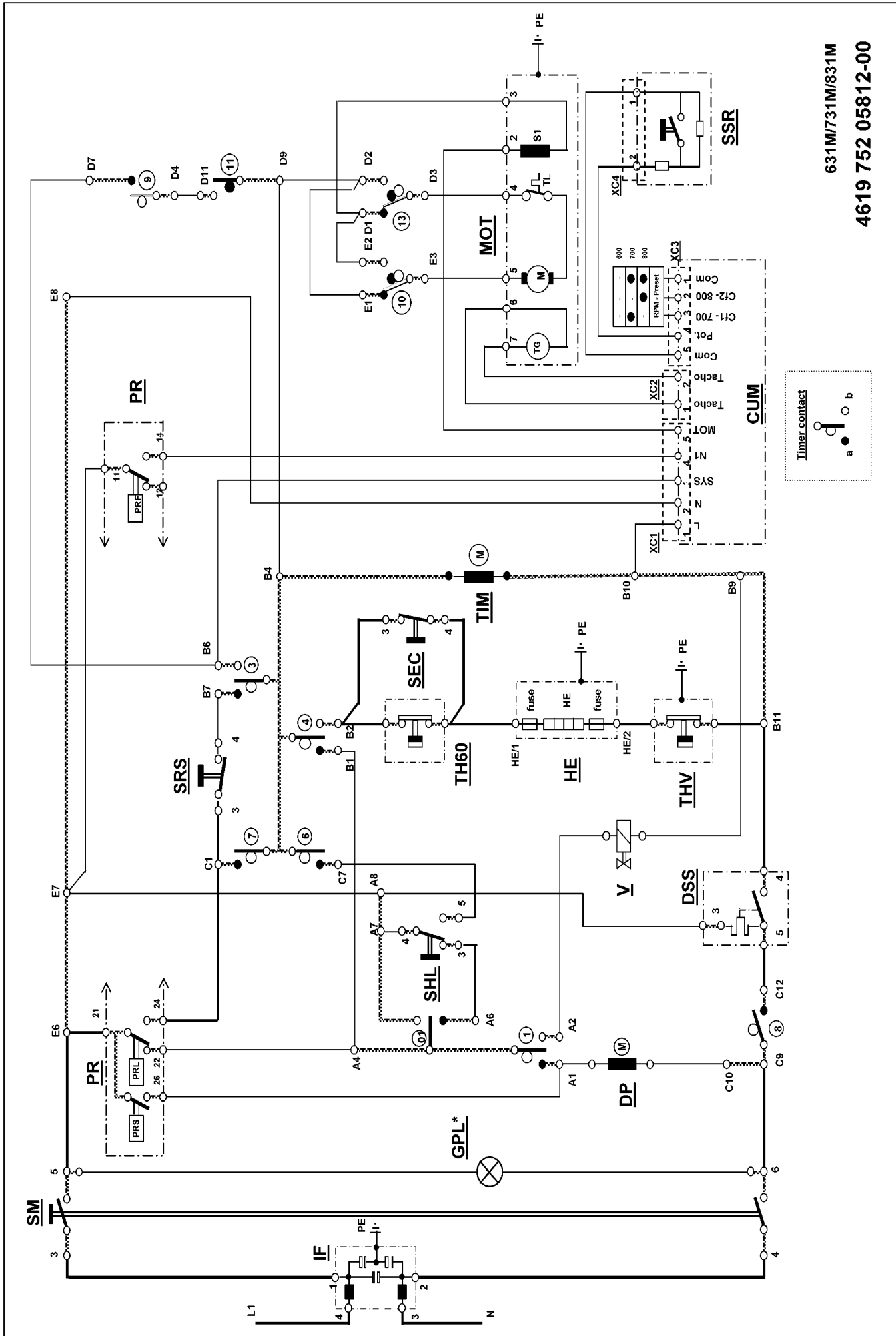

Program diagram

