

ALPINE

SERVICE MANUAL

MONO POWER AMPLIFIER

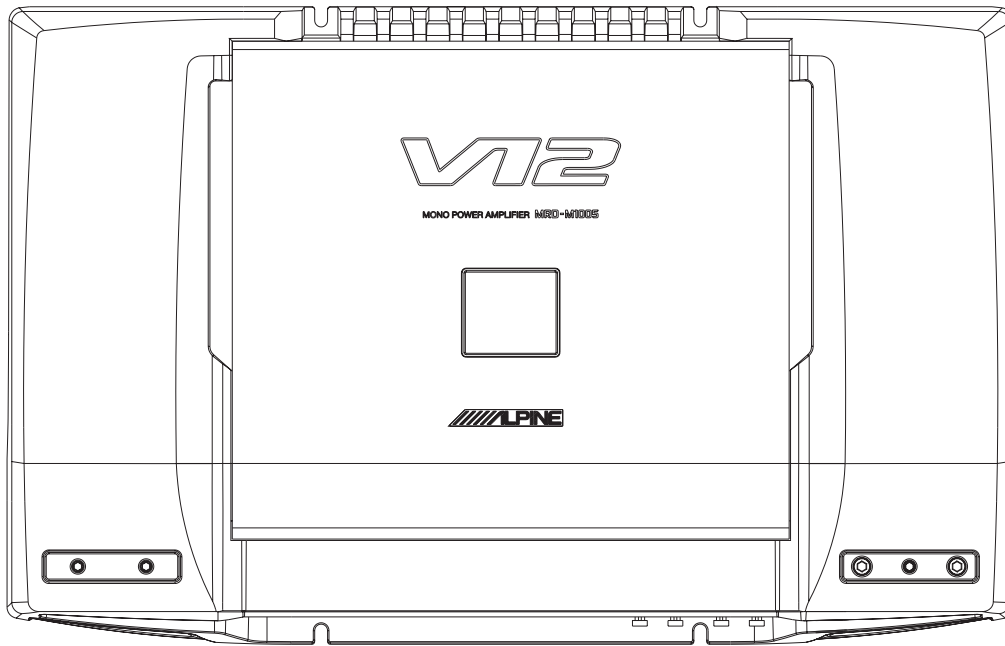

1 / 05-A
68E37841S01



MRD-M1005

<Cautions for Safe Repair Work>



The following cautions will prevent accidents in the workplace and will ensure safe products.

*The symbols indicate caution is needed to prevent injuries and damage to property.



The symbols and their meanings follow.

 Warning	If you ignore this symbol and handle the product incorrectly or unsafely, serious injury or death may result.
 Caution	If you ignore this symbol and handle the product incorrectly or unsafely, injury or only material damage may result.



*The following symbols indicate two levels of cautions.



 When you see this symbol, you have to be very careful.	
 When you see this symbol, you have to follow the instructions there.	



Warning

 Do not look squarely into the laser light coming from the pickup. You may lose your sight.	 Fuse Caution Always use a designated fuse. Use of an incorrect fuse may result in a fire.
--	--

Caution

 Do not allow wiring to be caught in the screw/chassis. If wiring is caught in the screw/chassis, it may cause a short circuit, resulting in a fire.	 Battery Caution Use the designated battery. Confirm the correct polarity and seat of the battery. An incorrect battery or an improperly connected or seated battery may result in a fire.
---	---

 High Temperature Caution Touching the heat sink may cause severe burns.	 Designated Parts Caution Look up the part list and ensure that only designated parts are used to prevent problems or accidents.
---	---

 Reverse Power Supply Connections or Misconnections Caution Reverse power supply connections or misconnections may cause ignition problems and smoke may result.	 Wiring Caution Ensure that the wiring is correct when rewiring to prevent problems with ignition/breakdown.
---	---

 Soldering Caution Hot solder from solder splash may cause severe burns.	 Wear Gloves Wear gloves to prevent electrical shocks or injury from the end face of the metal.
---	--

Contents

Packing Assembly Parts List	4
Packing Method View	4
Specifications	5
Extension Cable	6
Block Diagram	7
Parts Layout on P.W.Boards and Wiring Diagram	8 to 10
Schematic Diagram	11 to 15
Terminal Voltage of IC/TR	16 to 20
Description of IC Terminal	21
Exploded View (Cabinet)	22

NOTE : Due to continuing product improvement, specifications and designs are subject to change without notice.

Packing Assembly Parts List

Symbol No.	Part No.	Description	Symbol No.	Part No.	Description
101-1	03E36238S01	SCR,M4X20 TPG1			
101-2	03E36690S01	WRENCH,2.5X2.9			
101-3	03E36692S01	WRENCH,4X4.6			
#1 102	68-02278Z44	OWNER'S MANUAL			
\$1 102	68-02278Z45	OWNER'S MANUAL			
\$1 102	68-02278Z46	OWNER'S MANUAL			

NOTE:#1:For North American Model Only,\$1:For General Foreign Model Only,Others:Common.

Packing Method View

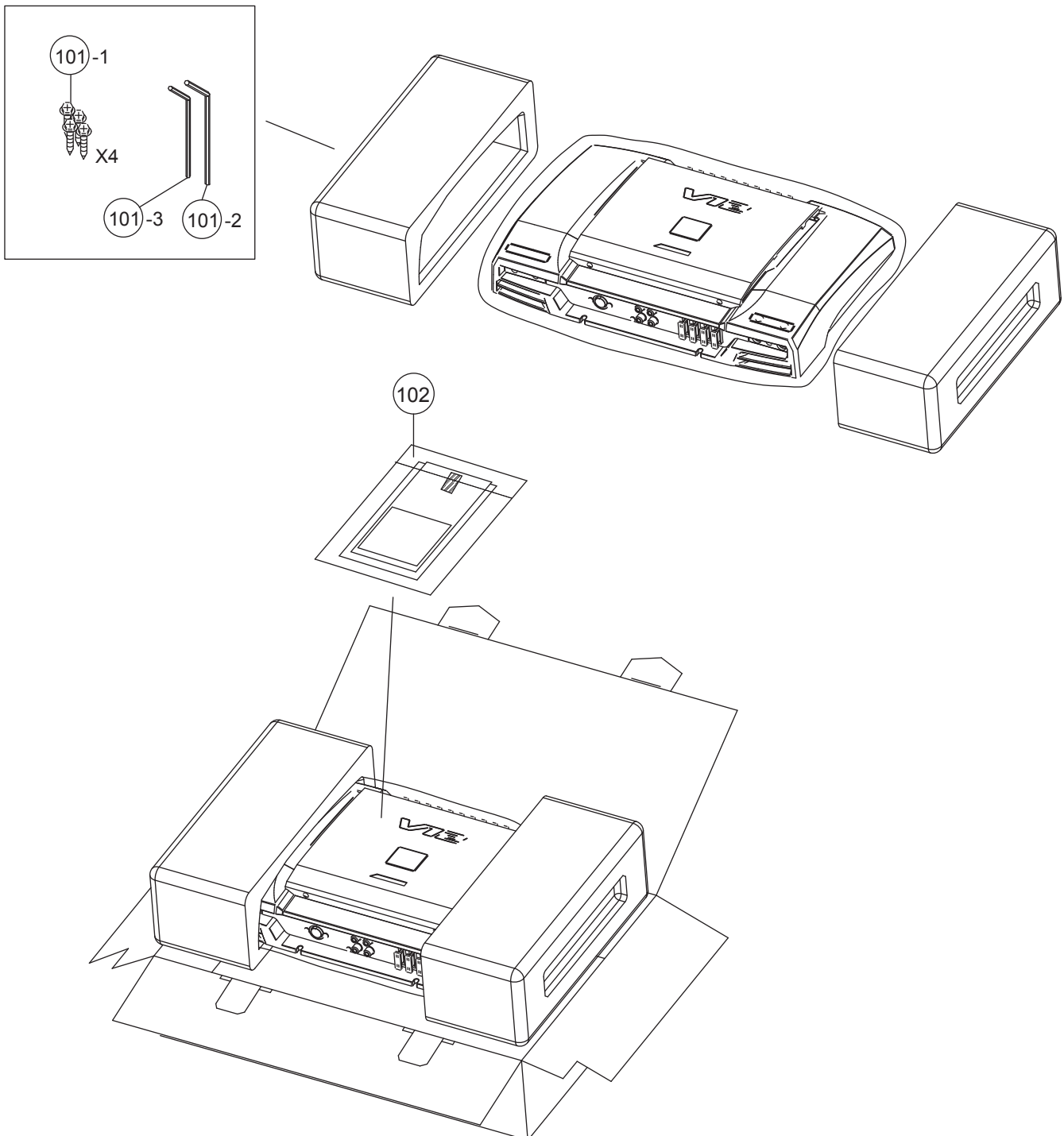

Specifications

Power Output	20Hz/100Hz, 4ohm, 1.0% T.H.D.(14.4V) : 500W 20Hz, 2ohm, 1.0% T.H.D.(14.4V) : 900W 100Hz, 2ohm, 1.0% T.H.D.(14.4V) : 1,000W
T.H.D. (100Hz, 400W/4ohm(14.4V), Display Gain position -12dB(0.5V))	1.0%
Residual Noise (Ref.Output 500W/4ohm, Input Short, Display Gain position -12dB(0.5V))	40mV
S/N Ratio (Ref.Output 500W/4ohm, Input Short, Display Gain position -12dB(0.5V))	80dB
Frequency Response (Ref.Output 500W/4ohm, Ref.100Hz 0dB)	20Hz : -0.5±2dB 200Hz : -3.0±2dB
Output Offset Voltage (No Signal)	±150mV
Remote On Voltage (1W Output)	6.5±1V
Current Drain	No Signal : 2.7A 10% T.H.D., 2ohm Load : 170A Remote Current Drain : 0.53±0.2mA Back Up Current Drain : 1.2mA
Input Sensitivity (Ref.) (Ref.Output 500W/4ohm)	Gain position 0.1V : RCA Input Level : 0.15V±2dB Gain position 0.2V : RCA Input Level : 0.24V±2dB Gain position 0.3V : RCA Input Level : 0.30V±2dB Gain position 0.4V : RCA Input Level : 0.47V±2dB Gain position 0.5V : RCA Input Level : 0.60V±2dB Gain position 0.7V : RCA Input Level : 0.75V±2dB Gain position 1.0V : RCA Input Level : 0.95V±2dB Gain position 1.5V : RCA Input Level : 1.50V±2dB Gain position 2.5V : RCA Input Level : 2.70V±2dB Gain position 4.0V : RCA Input Level : 4.0V±2dB Gain position 8.0V : RCA Input Level : 8.4V±2dB
Pre-Out Level at 1.0V Input (Ref.)	1.0V±2dB
Input Impedance (Ref.)	100k ohm±10%
Fuse Requirement	20A(Peak) x 4 (For Battery Line)
Power Source	DC14.4V (11 to 16V)
Dimensions (W x H x D)	360 x 60 x 227.8mm
Weight	5.1kg

NOTE : Due to Continuing product improvement, specifications and designs are subject to change without notice.

Extension Cable

*Always connect the Extension Cable when making checks of voltage and repair.

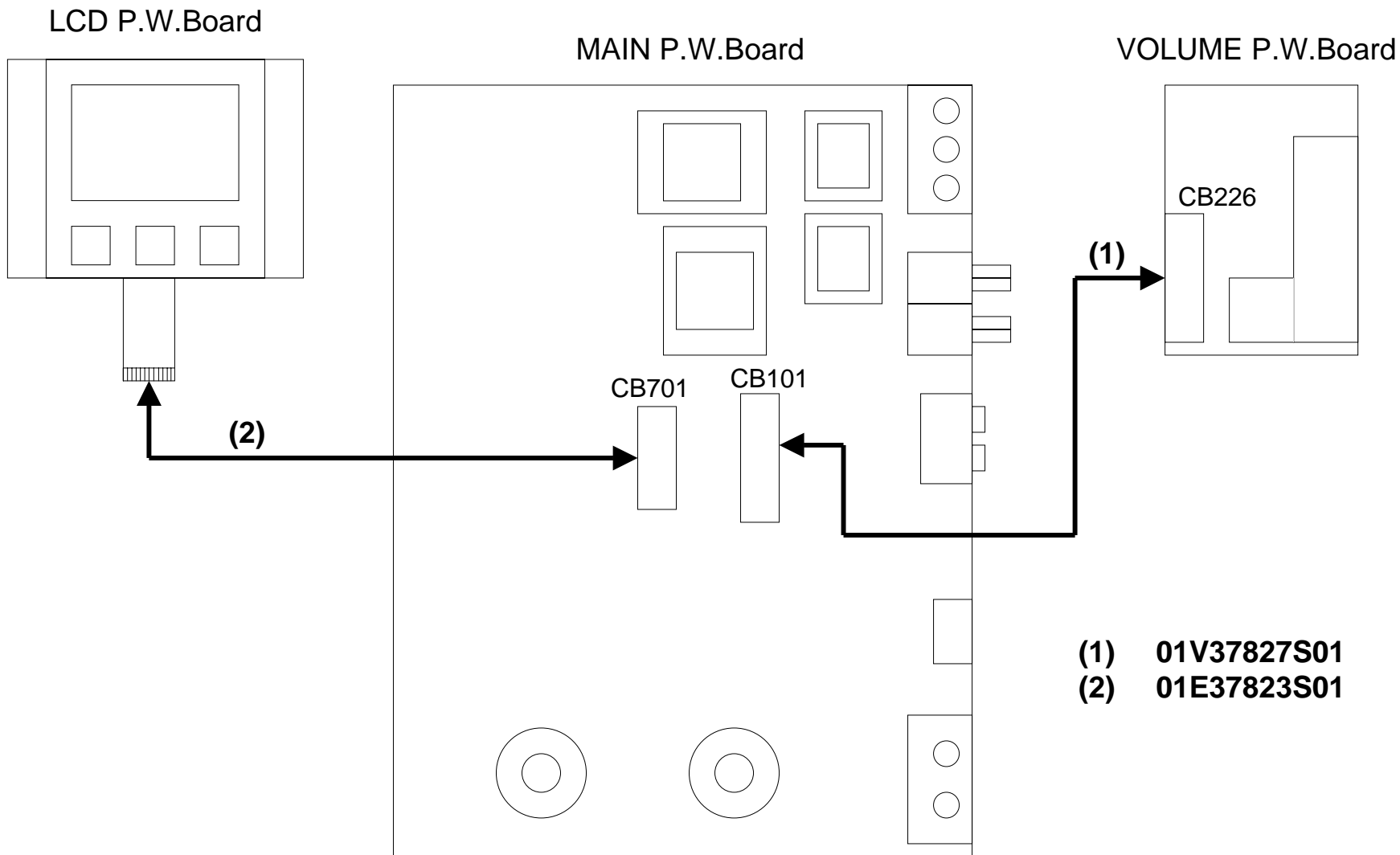

Block Diagram

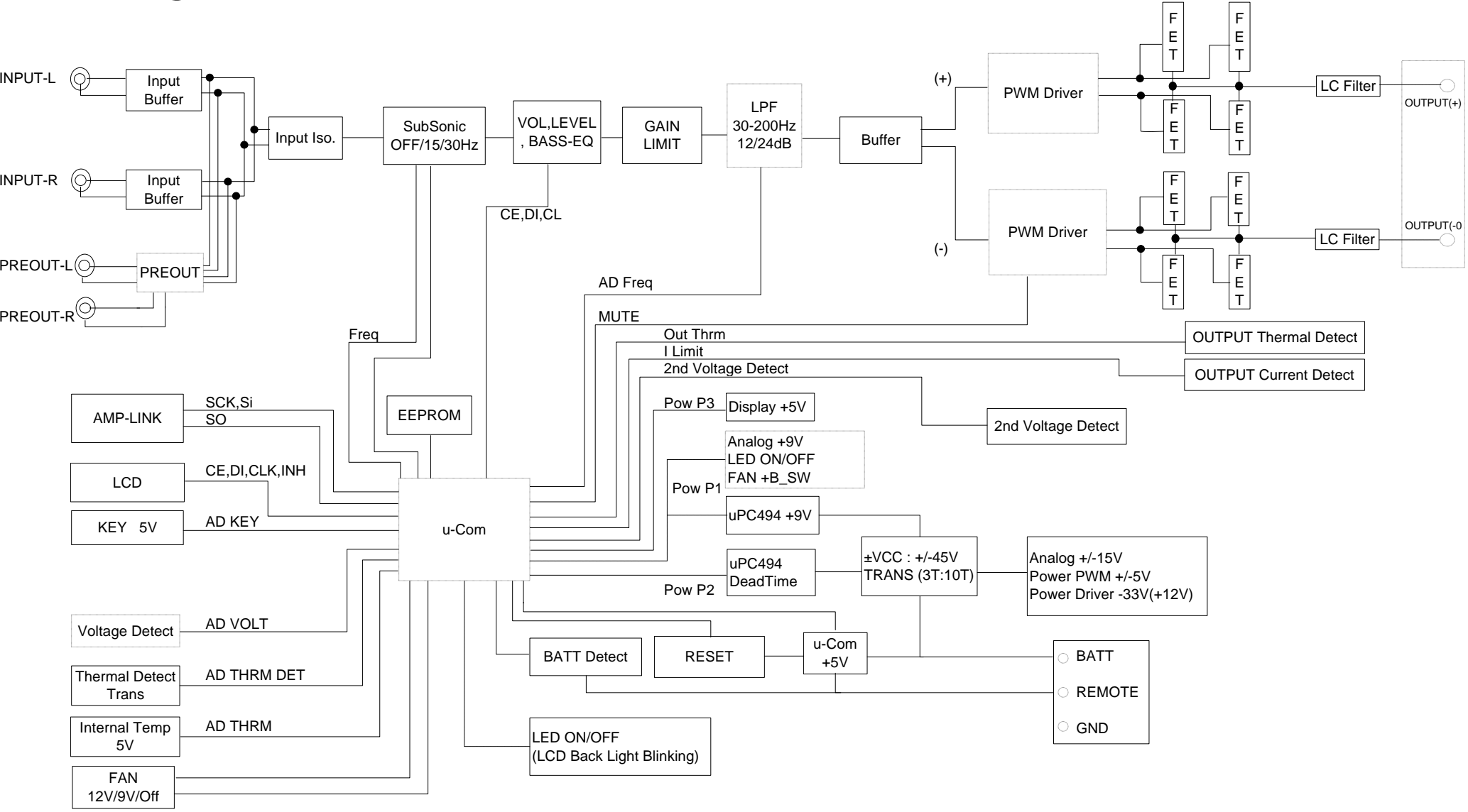

MAIN P.W.Board (Component Side View)

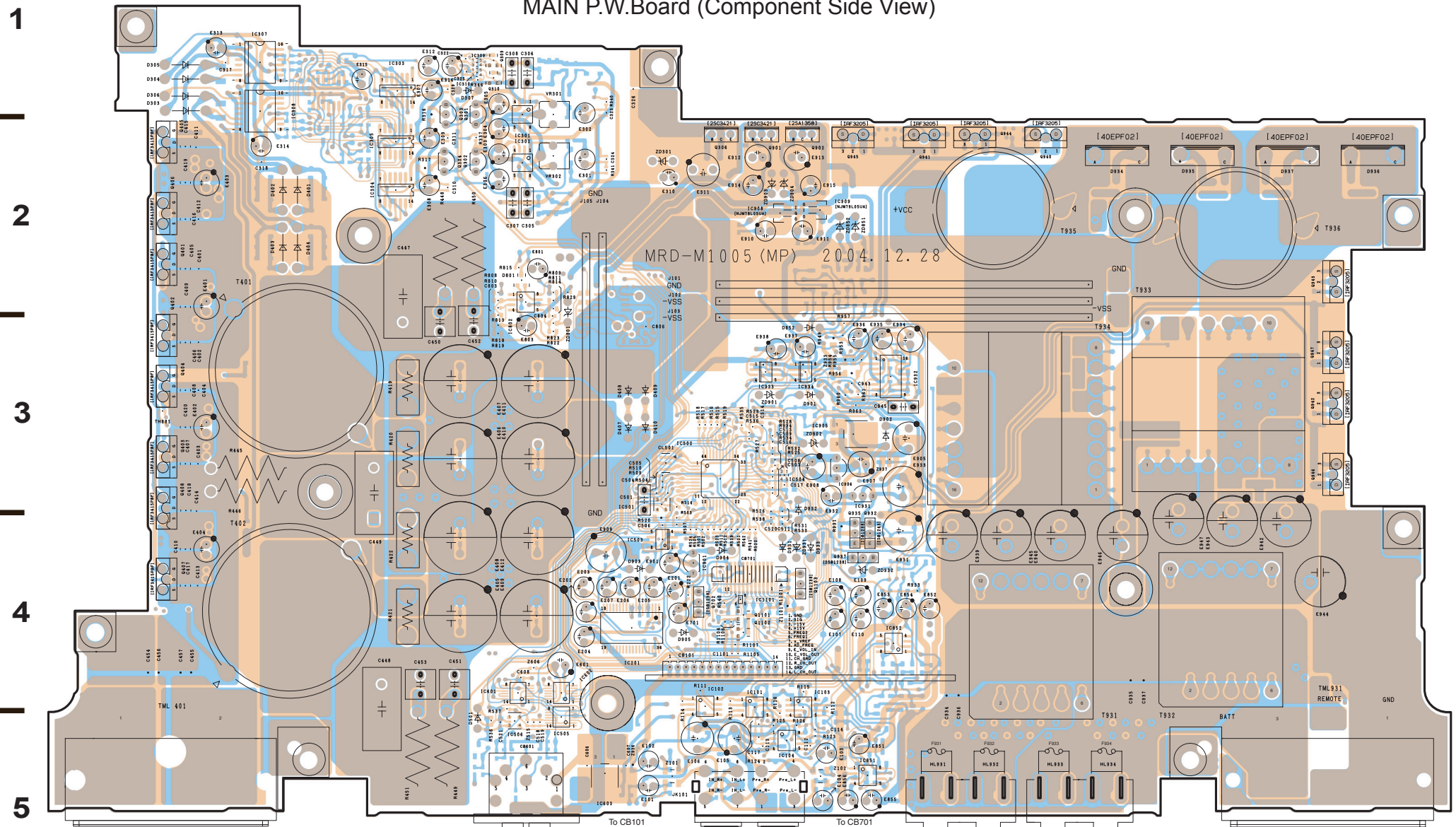

To CB101
From VOLUME P.W.Board (CB226)
To CB701
From LCD P.W.Board (C)

Orange Color Pattern:Component Side Pattern
Blue Color Pattern:Foil Side Pattern

A | B | C | D | E | F | G

1
2
3
4
5

MAIN P.W.Board (Foil Side View)

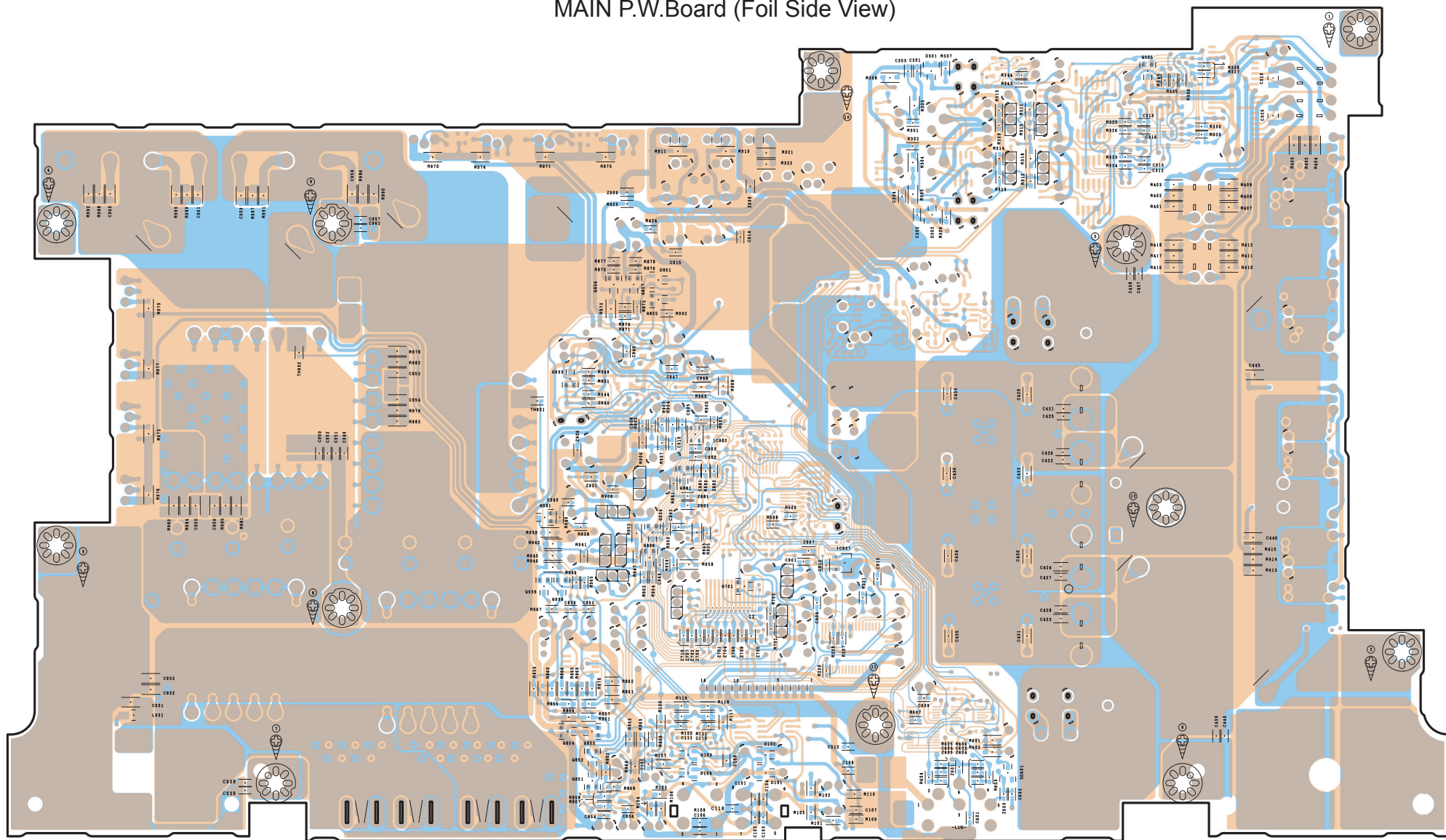

Orange Color Pattern:Component Side Pattern
Blue Color Pattern:Foil Side Pattern

A | B | C | D | E | F | G

1

LCD P.W.Board
(Component Side View)

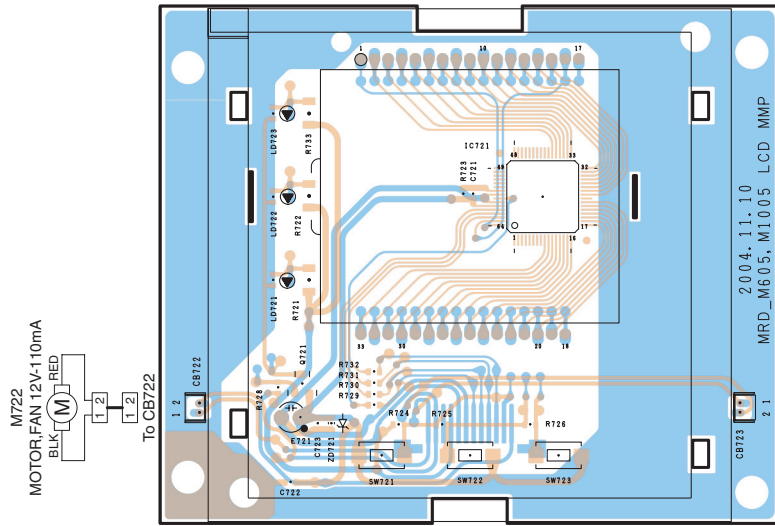

LCD P.W.Board
(Foil Side View)

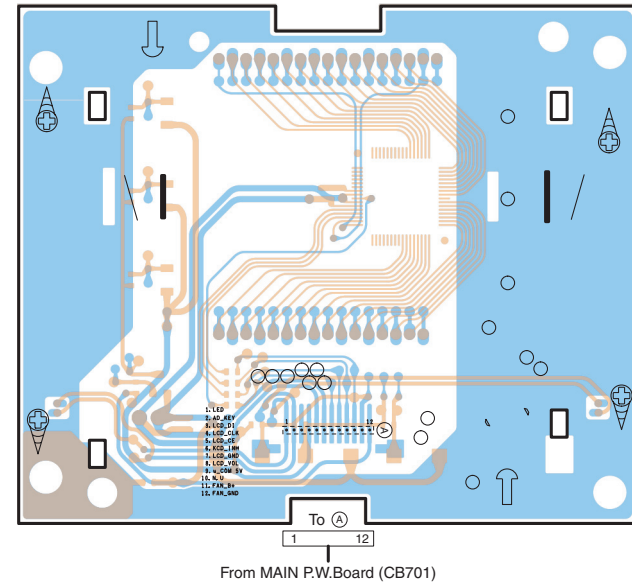

2

3

VOLUME P.W.Board
(Component Side View)

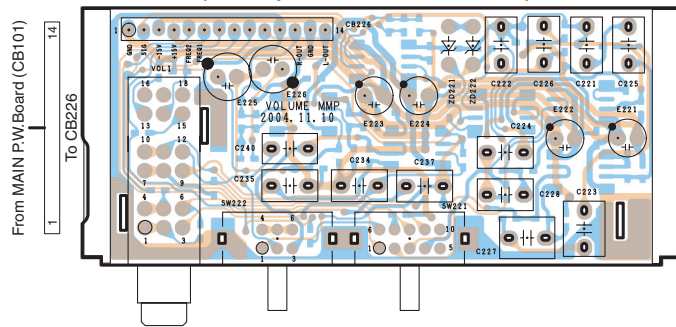

VOLUME P.W.Board
(Foil Side View)

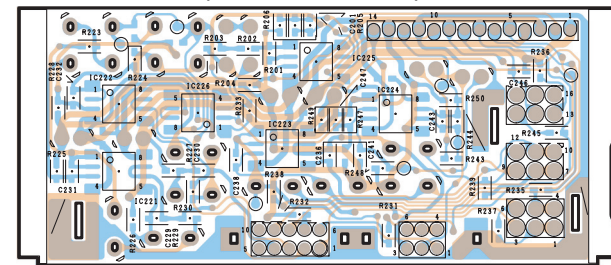

4

5

Orange Color Pattern:Component Side Pattern
Blue Color Pattern:Foil Side Pattern

A | B | C | D | E | F | G

Schematic Diagram(1/5)

MRD-M1005

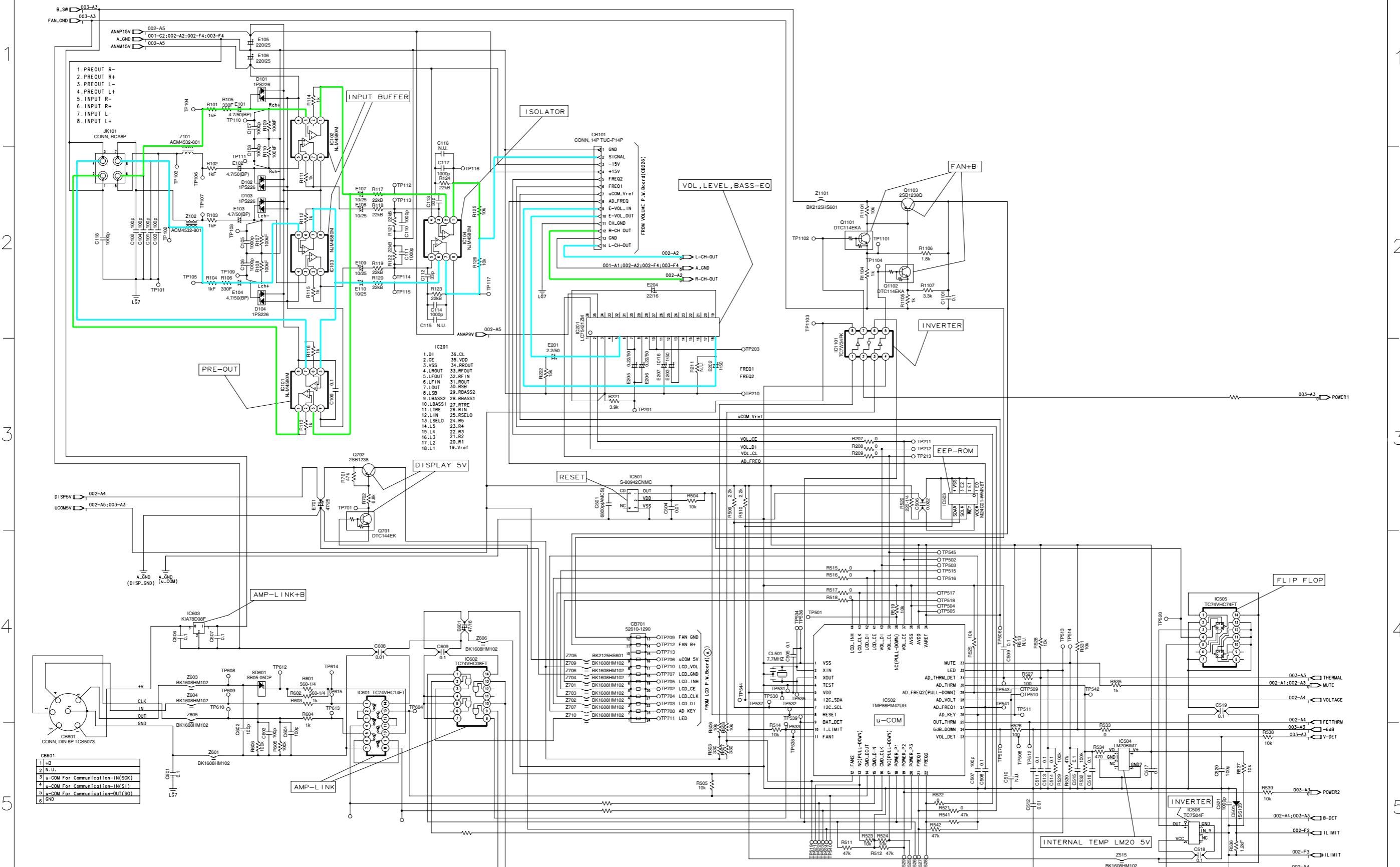

MAIN P.W. Board(1/3)
NOTE: N.U. is Not Used Parts.

Schematic Diagram(2/5)

MRD-M1005

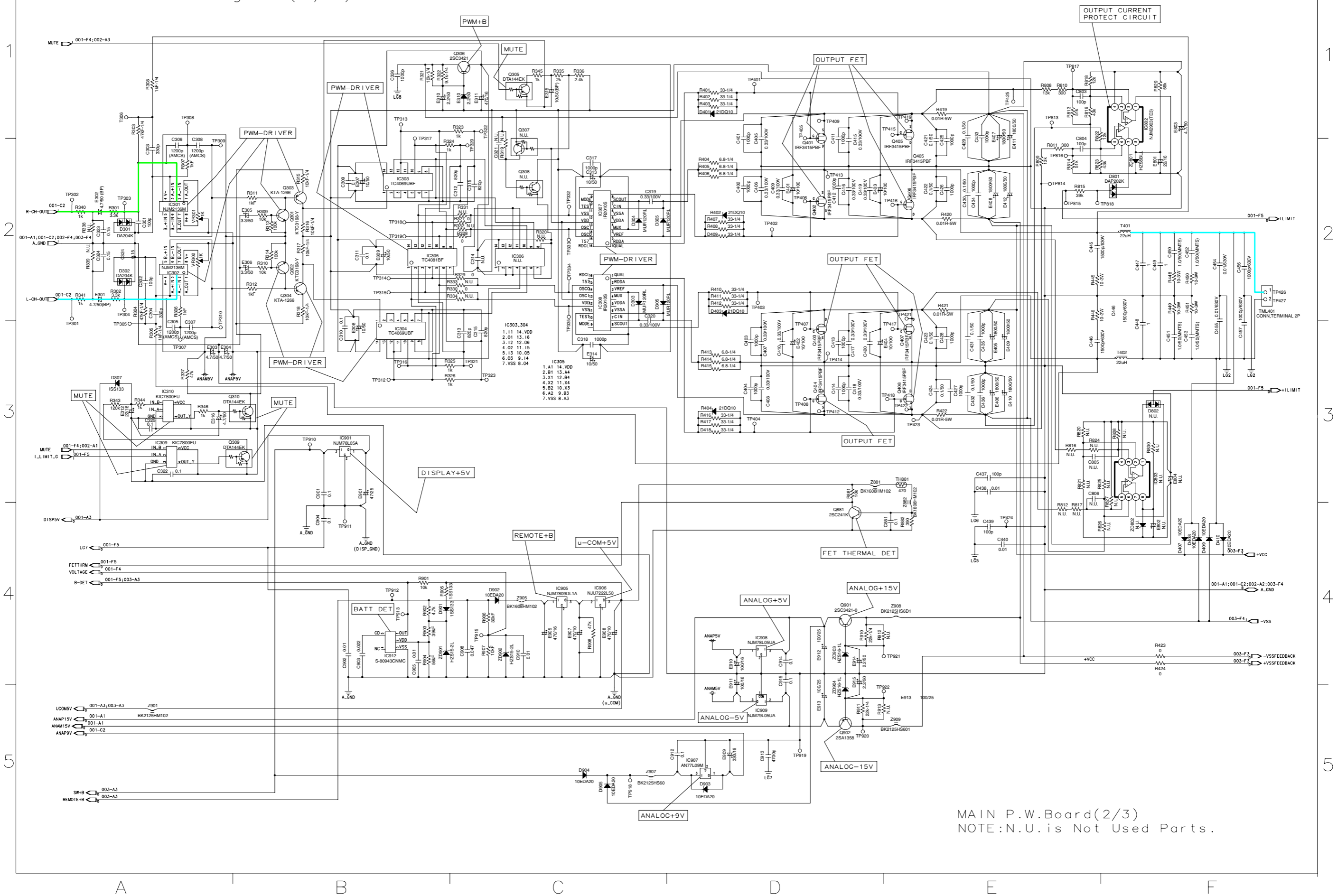

MAIN P.W.Board(2/3)
NOTE:N.U. is Not Used Parts.

Schematic Diagram(3/5)

MRD-M1005

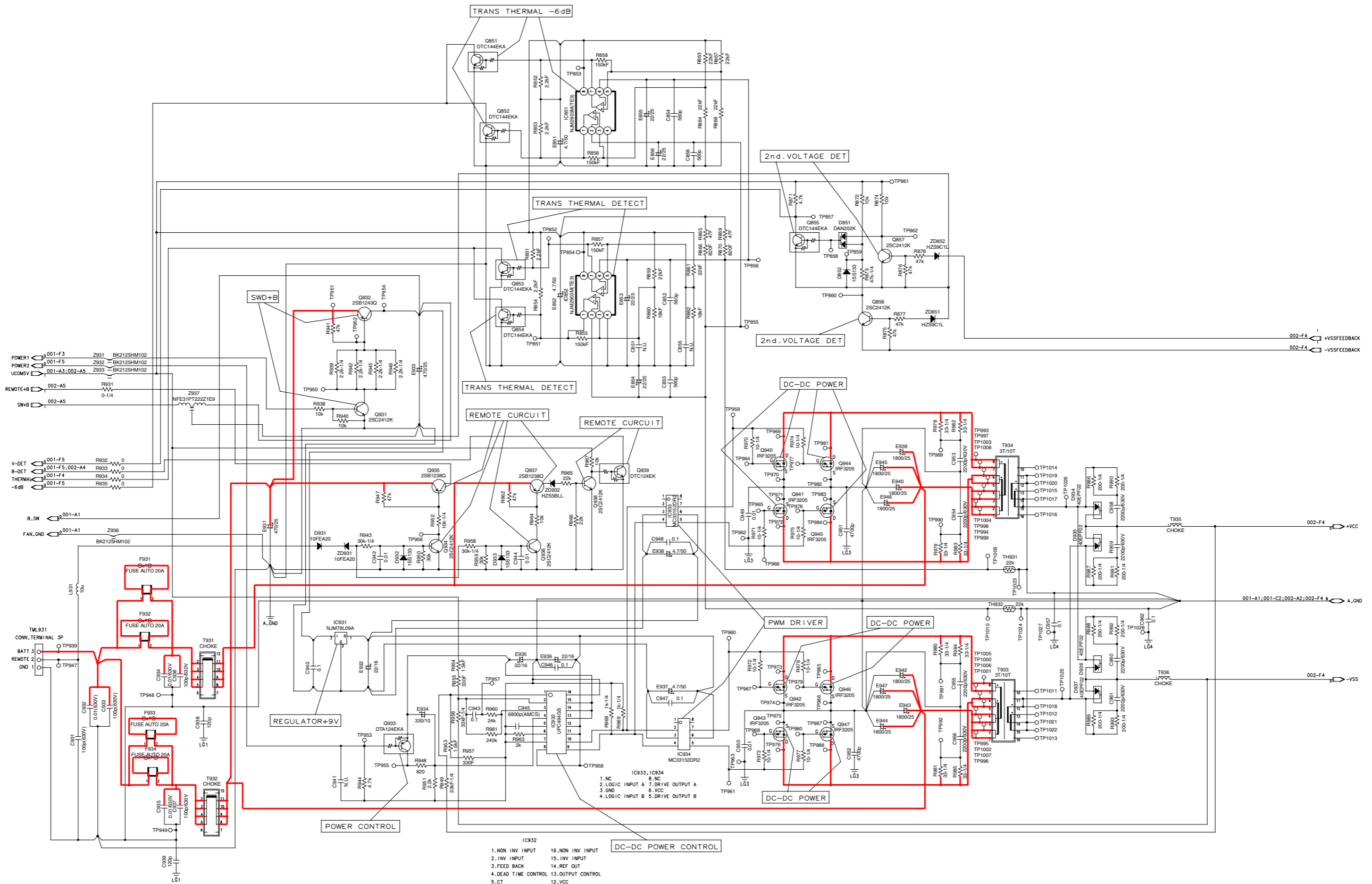

MAIN P.W.Board(3/3)
NOTE:N.U.is Not Used Parts.

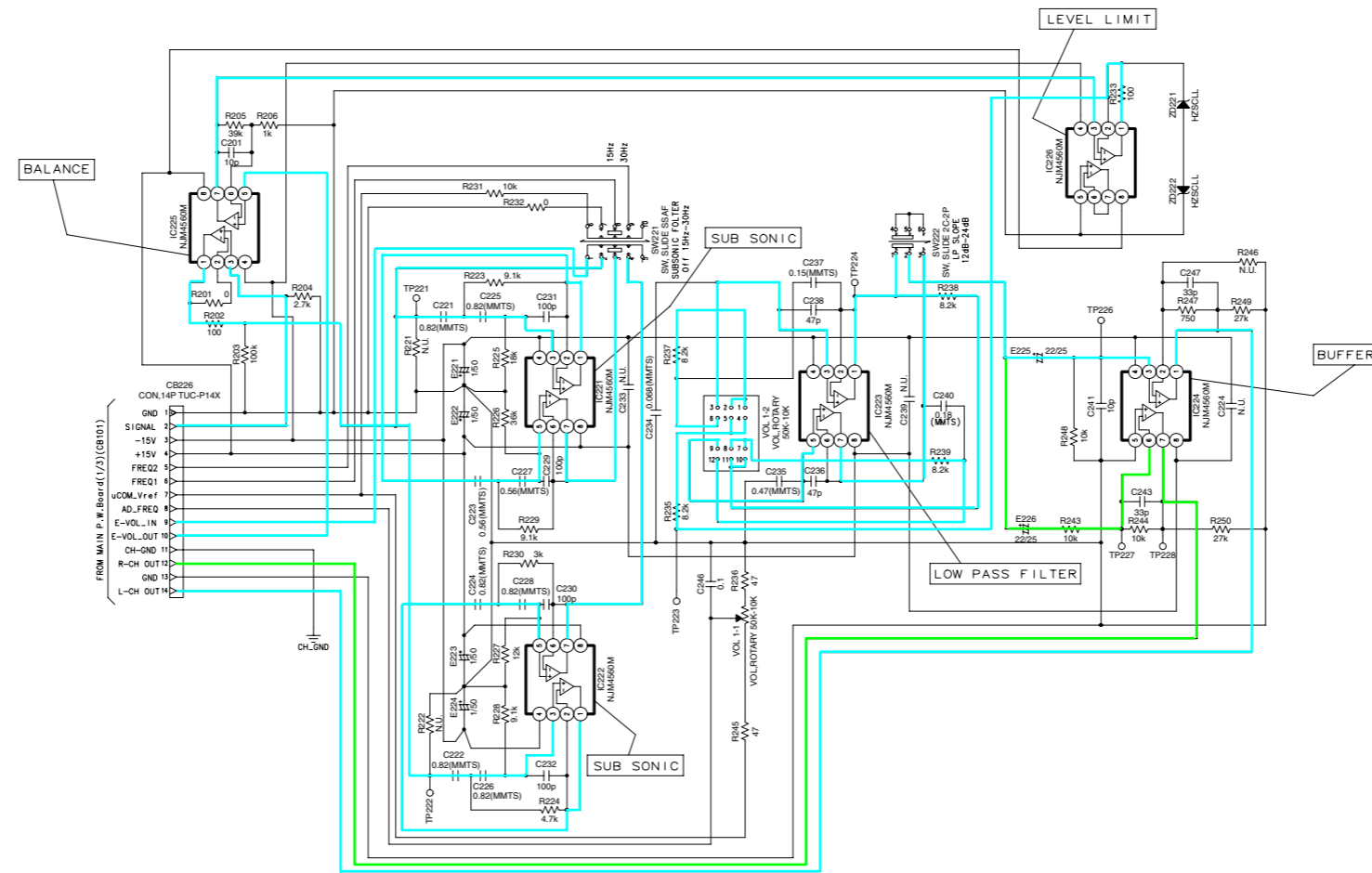

VOLUME P.W.Board
NOTE:N.U. is Not Used Parts.

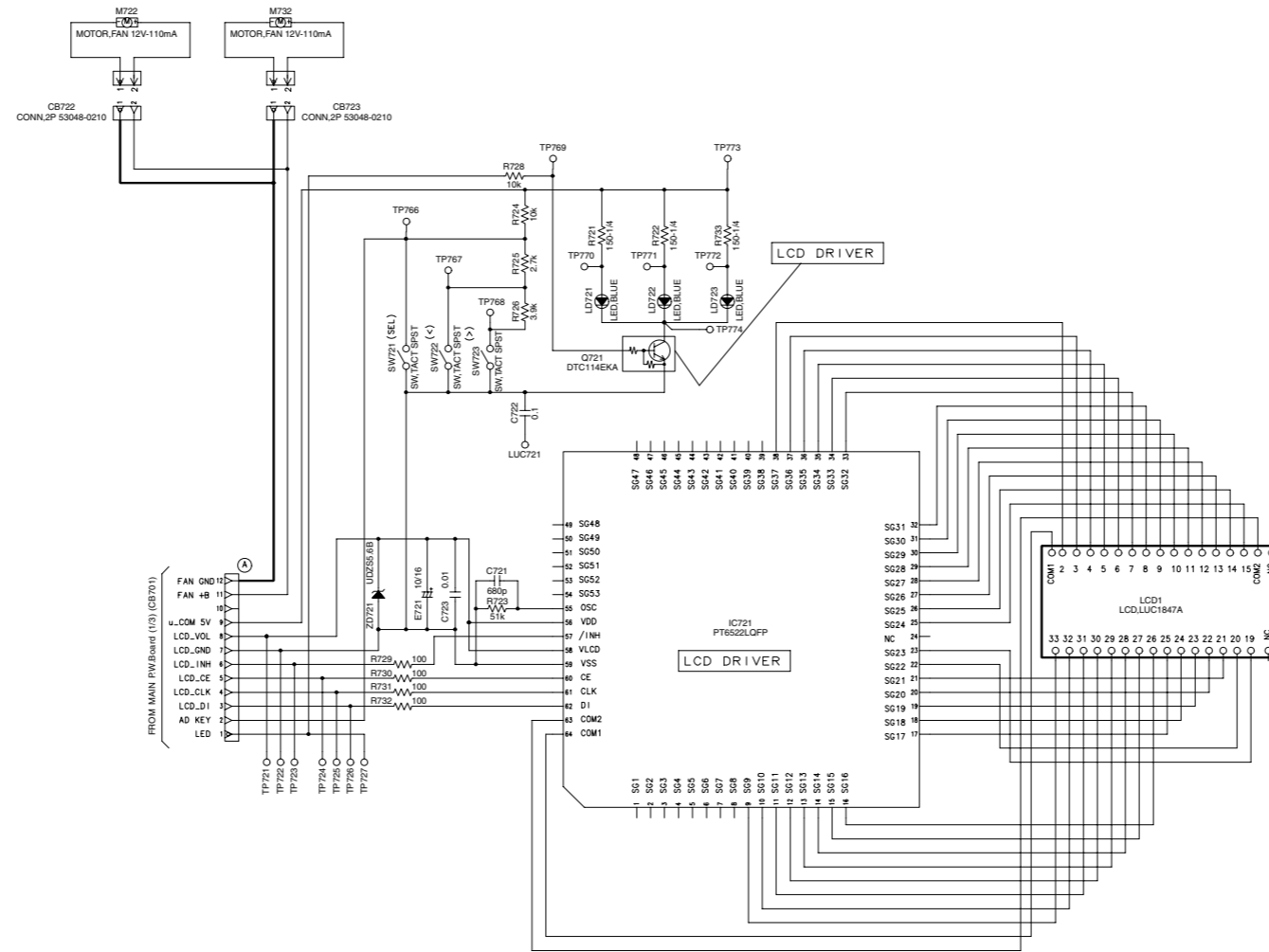

LCD P.W.Board
NOTE:N.U.is Not Used Parts.

Terminal Voltage of IC/TR

IC101	
1	0.02
2	0.02
3	0.02
4	-15.55
5	0.02
6	0.02
7	0.02
8	15.58

IC102	
1	0.02
2	0.02
3	0.02
4	-15.55
5	0.02
6	0.02
7	0.02
8	15.57

IC103	
1	0.02
2	0.02
3	0.02
4	-15.24
5	0.02
6	0.02
7	0.02
8	15.24

IC104	
1	0.00
2	0.00
3	0.00
4	15.24
5	0.00
6	0.00
7	0.00
8	15.24

IC201					
1	0.00	13	4.48	25	NC
2	0.00	14	NC	26	NC
3	0.00	15	NC	27	NC
4	NC	16	NC	28	NC
5	NC	17	NC	29	NC
6	4.50	18	4.48	30	NC
7	4.50	19	4.50	31	NC
8	4.50	20	NC	32	NC
9	4.50	21	NC	33	NC
10	4.50	22	NC	34	NC
11	4.47	23	NC	35	0.00
12	0.00	24	NC	36	0.00

IC221	
1	0.01
2	0.01
3	0.01
4	-15.29
5	0.01
6	0.01
7	0.01
8	15.34

IC222	
1	0.00
2	0.00
3	0.01
4	-15.43
5	0.01
6	0.00
7	0.00
8	14.48

IC223	
1	0.02
2	0.02
3	0.03
4	-15.34
5	0.03
6	0.03
7	0.03
8	15.38

IC224	
1	0.01
2	0.04
3	0.01
4	-15.35
5	0.01
6	0.01
7	0.01
8	15.39

IC225	
1	0.01
2	0.01
3	0.01
4	-15.33
5	0.03
6	0.03
7	0.03
8	15.33

IC226	
1	0.03
2	0.03
3	0.03
4	-15.40
5	0.01
6	0.01
7	0.01
8	15.39

MRD-M1005

IC301	
1	5.00
2	0.00
3	0.00
4	-4.95
5	0.00
6	1.58
7	5.01
8	5.00

IC302	
1	5.00
2	0.00
3	0.00
4	-4.95
5	0.00
6	1.54
7	5.01
8	5.00

IC303			
1	-32.24	8	NC
2	-38.44	9	-43.91
3	-38.44	10	-38.53
4	-37.58	11	-38.54
5	-37.59	12	-38.43
6	-38.44	13	-38.52
7	-43.92	14	-32.02

IC304			
1	-43.91	8	NC
2	-38.49	9	-43.91
3	-37.65	10	-38.56
4	-37.61	11	-37.60
5	-38.45	12	-37.60
6	-38.45	13	-38.45
7	-38.04	14	-32.11

IC305			
1	-38.59	8	-37.58
2	-38.47	9	-37.60
3	-40.31	10	-39.00
4	-39.00	11	-40.28
5	-37.57	12	-38.46
6	-37.52	13	-38.54
7	-43.86	14	-32.09

IC307			
1	-39.95	9	NC
2	-43.96	10	NC
3	-32.43	11	-32.42
4	NC	12	-40.40
5	NC	13	-43.61
6	0.00	14	-39.15
7	10.69	15	-43.97
8	2.75	16	NC

IC308			
1	-39.98	9	NC
2	-42.96	10	NC
3	-32.43	11	-32.42
4	NC	12	-40.42
5	NC	13	-43.54
6	0.00	14	-39.16
7	10.72	15	-43.96
8	2.72	16	NC

IC309	
1	4.97
2	4.97
3	0.00
4	0.01
5	5.01

IC310	
1	4.97
2	5.01
3	0.00
4	0.01
5	5.01

IC501	
1	4.99
2	4.49
3	0.01
4	NC
5	0.01

IC502							
1	0.00	12	0.35	23	4.97	34	4.98
2	2.11	13	0.03	24	4.97	35	4.98
3	2.28	14	4.97	25	0.01	36	0.00
4	0.00	15	0.00	26	4.97	37	0.01
5	4.98	16	0.00	27	4.96	38	0.01
6	4.98	17	0.03	28	3.56	39	0.01
7	4.98	18	4.97	29	0.02	40	0.01
8	4.94	19	4.88	30	1.46	41	0.42
9	4.99	20	4.97	31	4.97	42	0.10
10	4.97	21	0.01	32	4.97	43	0.08
11	0.36	22	0.01	33	4.97	44	4.98

MRD-M1005

IC503	
1	0.00
2	0.01
3	0.01
4	0.01
5	4.97
6	4.97
7	0.01
8	4.97

IC504	
1	NC
2	0.00
3	1.50
4	4.98
5	0.00

IC505			
1	4.95	8	NC
2	0.01	9	NC
3	0.01	10	0.01
4	4.98	11	0.01
5	4.94	12	0.01
6	NC	13	0.01
7	4.94	14	4.95

IC506	
1	NC
2	4.97
3	0.00
4	0.01
5	4.95

IC601	
1	0.00
2	0.00
3	4.97
4	0.00
5	0.00
6	4.96
7	0.00
8	0.00
9	4.96
10	4.97
11	0.00
12	0.00
13	4.97
14	4.97

IC602	
1	4.97
2	4.97
3	0.02
4	0.01
5	0.01
6	NC
7	0.01
8	4.97
9	4.97
10	4.94
11	NC
12	NC
13	4.94
14	4.96

IC603	
1	14.35
2	0.00
3	8.84

IC721							
1	NC	17	2.42	33	2.42	49	NC
2	NC	18	0.76	34	2.42	50	NC
3	NC	19	2.41	35	2.42	51	NC
4	NC	20	2.41	36	1.50	52	NC
5	NC	21	2.41	37	2.41	53	NC
6	NC	22	2.42	38	2.42	54	NC
7	NC	23	2.42	39	NC	55	
8	NC	24	0.67	40	NC	56	4.90
9	2.42	25	2.42	41	NC	57	4.99
10	2.42	26	2.42	42	NC	58	4.90
11	2.42	27	2.72	43	NC	59	0.03
12	2.42	28	2.42	44	NC	60	0.00
13	0.71	29	2.42	45	NC	61	0.00
14	0.69	30	2.42	46	NC	62	0.10
15	2.42	31	2.42	47	NC	63	1.70
16	2.42	32	2.42	48	NC	64	1.71

IC802	
1	4.99
2	-34.90
3	-34.25
4	-43.86
5	-34.26
6	-34.87
7	4.96
8	-4.78

IC851	
1	0.11
2	4.67
3	2.11
4	0.00
5	2.32
6	4.63
7	0.11
8	4.97

IC852	
1	0.11
2	4.68
3	2.10
4	0.00
5	2.11
6	4.65
7	0.11
8	4.97

IC901	
1	4.96
2	0.00
3	14.35

IC902	
1	0.00
2	6.98
3	0.01
4	NC
5	0.01

IC905	
1	9.00
2	0.00
3	13.44

IC906	
1	0.00
2	9.01
3	5.02

IC907	
1	9.02
2	0.01
3	0.00

IC908	
1	5.01
2	0.00
3	15.25

IC909	
1	0.00
2	-15.35
3	-4.95

IC931	
1	8.90
2	0.00
3	14.38

IC932	
1	2.22
2	1.72
3	2.18
4	0.00
5	1.68
6	3.44
7	0.00
8	8.90
9	2.20
10	2.21
11	8.90
12	8.90
13	5.03
14	5.03
15	5.03
16	0.00

IC933	
1	NC
2	2.22
3	0.01
4	2.21
5	2.57
6	8.90
7	2.58
8	NC

IC934	
1	NC
2	2.22
3	0.01
4	2.21
5	2.58
6	8.90
7	2.59
8	NC

IC1101	
1	0.41
2	0.00
3	4.92
4	0.01
5	0.01
6	4.97
7	0.01
8	4.98

FET	G	D	S
Q401	-40.52	-0.01	-43.93
Q402	2.18	45.62	-0.01
Q403	2.11	45.62	-0.01
Q404	-40.52	-0.01	-43.93
Q405	-40.51	-0.01	-0.01
Q406	2.19	45.62	-0.01
Q407	2.13	45.62	-43.94
Q408	-40.61	-0.01	0.00
Q940	2.54	14.40	0.00
Q941	2.52	14.40	0.00
Q942	2.54	14.40	0.00
Q943	2.54	14.40	0.00
Q944	2.53	14.40	0.00
Q945	2.52	14.40	0.00
Q946	2.54	14.40	0.00
Q947	2.54	14.40	0.00

TR	E	B	C
Q301	-4.92	-4.96	-1.56
Q302	-4.92	-4.96	-1.54
Q303	-1.58	-.08	-38.24
Q304	-1.55	-.08	-38.23
Q305	5.01	-43.63	4.97
Q306	-32.39	0.00	-31.84
Q309	5.01	4.98	0.02
Q310	5.01	4.98	0.02
Q701	1.85	1.83	1.85
Q702	4.98	4.90	4.30
Q721	0.01	0.36	2.83
Q851	0.00	4.98	0.10
Q852	0.00	4.98	0.11
Q853	0.00	4.98	0.10
Q854	0.00	4.98	0.11
Q855	0.00	4.97	0.00
Q856	-43.95	-43.96	-43.27
Q857	0.00	0.00	0.69
Q881	0.00	0.01	0.77
Q901	15.25	45.50	15.85
Q902	-15.28	-43.96	-15.86
Q931	0.00	0.13	0.73
Q932	14.38	14.35	13.65
Q933	5.03	0.00	4.78
Q934	0.00	0.02	0.65
Q935	14.38	14.22	13.66
Q936	0.00	0.02	0.65
Q937	14.39	14.39	13.74
Q938	0.00	0.10	0.66
Q939	0.00	5.03	0.01
Q1101	0.00	15.35	0.02
Q1102	0.01	14.35	0.02
Q1103	14.35	0.00	14.34

[Measuring Conditions]

- 1.Power Supply Voltage : DC 14.4V
- 2.Measuring Meter : Digital Multi Voltmeter
- 3.Measuring Point Reference : Between GND
- 4.Measuring Condition : No Signal Input

Description of IC Terminal

TMP86PM47AUG : IC502

No.	Symbol	I/O	Terminal Description
1	VSS	I	GND connect terminal.
2	XIN	I	Crystal OSC connect terminal.
3	XOUT	O	
4	TEST	I	TEST terminal.
5	VDD	-	Power supply terminal. (4.5 to 5.5V)
6	I2C_SDA	O	I2C_SDA output terminal.
7	I2C_SCL	O	I2C_SCL output terminal.
8	RESET	I	RESET terminal.
9	BAT_DET	I	BAT-DET terminal.
10	I_LIMIT	I	I_LIMIT input terminal.
11	FAN1	O	FAN power supply control terminal. (9V)
12	FAN2	O	FAN power supply control terminal. (12V)
13	NC(PULL-DOWN)	-	Pull-down connect terminal.
14	CMD_DOUT	O	AMP LINK data output terminal.
15	CMD_DIN	I	AMP LINK data input terminal.
16	CMD_CLK	I	AMP LINK clock terminal.
17	NC(PULL-DOWN)	-	Pull-down connect terminal.
18	POWER_P1	O	Power supply circuit control signal output terminal -1.
19	POWER_P2	O	Power supply circuit control signal output terminal -2.
20	POWER_P3	O	Power supply circuit control signal output terminal -3. (for LCD circuit)
21	FREQ1	I	Subsonic 15Hz input terminal.
22	FREQ2	I	Subsonic 30Hz input terminal.
23	VOL_DET	I	VOL-DET terminal. (Secondary voltage, DC-OFFSET)
24	6dB_DOWN	I	-6dB temperature detection input terminal.
25	OUT_THRM	I	Output Thermal detect terminal.
26	AD_KEY	I	KEY level input terminal.
27	AD_FREQ1	I	Frequency signal input terminal.
28	AD_VOLT	I	Voltage signal input terminal.
29	AD_FREQ2 (PULL-DOWN)	-	Pull-down connect terminal.
30	AD_THRM	I	Temperature signal input terminal.
31	AD_THRM_DET	I	Temperature detection input terminal.
32	LED	O	LED (Back Light) ON output terminal.
33	MUTE	O	MUTE output terminal.
34	VAREF	-	Analog reference power supply terminal for A/D converter.
35	AVDD	-	Power supply terminal for A/D converter.
36	AVSS	-	Analog reference GND terminal for A/D converter.
37	VOL_CE	O	E-VOL chip enable terminal.
38	NC(PULL-DOWN)	-	Pull-down connect terminal.
39	VOL_CL	O	E-VOL synchronous clock terminal.
40	VOL_DI	O	E-VOL transmission data terminal.
41	LCD_CE	O	LCD driver chip enable terminal.
42	LCD_DI	O	LCD driver transmission data terminal.
43	LCD_CLK	O	LCD driver synchronous clock terminal.
44	LCD_INH	O	LCD driver INH terminal.

Exploded View (Cabinet)

MRD-M1005

