

TC-H2700/H3700

SERVICE MANUAL

AEP Model

UK Model

TC-H2700/H3700

E Model

Australian Model

Tourist Model

TC-H2700



Discard TC-H3700
Service Manual
(No. 9-956-999-11)
Previously issued.
This Service Manual
contains it.

This set is the cassette deck
section in FH-E757, MHC-2700/3700.

SPECIFICATIONS

Recording system 4-track 2-channel stereo
Frequency response (DOLBY NR OFF)
40 — 13,000 Hz (± 3 dB),
using TYPE I cassette
(Sony HF-S)
40 — 14,000 Hz (± 3 dB),
using TYPE II cassette
40 — 15,000 Hz (± 3 dB) using
TYPE IV cassette
Wow and flutter 0.1% WRMS $\pm 0.3\%$ (DIN)
Inputs
PHONO (phono jacks):
sensitivity 2.5 mV,
impedance 47 kilohms
DAT (phono jacks):
sensitivity 450 mV,
impedance 47 kilohms
VIDEO (phono jacks):
sensitivity 300 mV,
impedance 47 kilohms

Design and specifications subject to change
without notice.

- Dolby noise reduction and HX Pro
headroom extension manufactured under
license from Dolby Laboratories Licensing
Corporation. HX Pro originated by Bang &
Olufsen.
"DOLBY", the double-D symbol $\square\square$, and
"HX PRO" are trademarks of Dolby
Laboratories Licensing Corporation.

Model Name Using Similar Mechanism		TC-H2600/H6600
Tape Transport Mechanism Type	EXCEPT H3700: UK, G	DECK A TCM-190RA13A
	H3700: UK, G	DECK B TCM-190RB22A
		DECK B TCM-190RB12A

• G: Germany model

SAFETY-RELATED COMPONENT WARNING!!

COMPONENTS IDENTIFIED BY MARK \triangle OR DOTTED LINE WITH MARK \triangle ON THE SCHEMATIC DIAGRAMS AND IN THE PARTS LIST ARE CRITICAL TO SAFE OPERATION. REPLACE THESE COMPONENTS WITH SONY PARTS WHOSE PART NUMBERS APPEAR AS SHOWN IN THIS MANUAL OR IN SUPPLEMENTS PUBLISHED BY SONY.

STEREO CASSETTE DECK
SONY[®]

CAUTION WHEN REPAIRING

Normally the power of this set is supplied from the TA-H2700/H3700 amplifier connected. When only this set is repaired, connect the power of 18V AC as shown in the figure below.

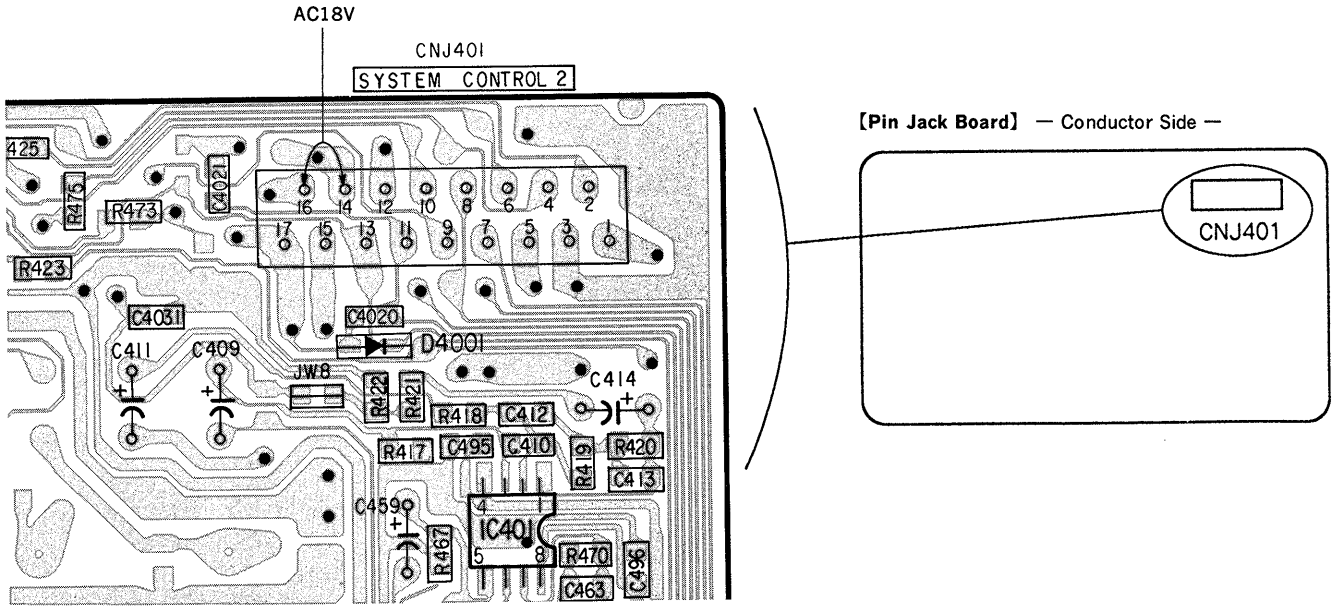

MODEL IDENTIFICATION

— BACK PANEL —

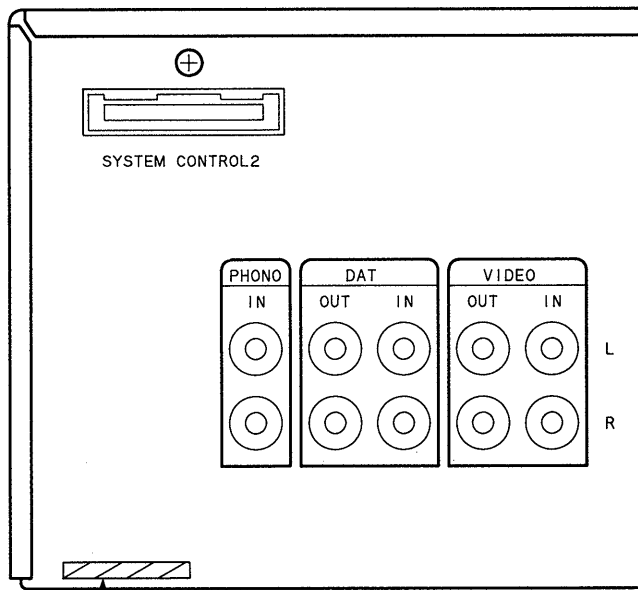

- 3-374-471-21 (AE) : H3700: AEP model
- 3-374-471-31 (AE4): H3700: Germany model
- 3-374-471-41 (AE) : H2700: AEP, UK, E, Australian, Tourist model
- 3-374-471-51 (AE4): H2700: Germany model
- 3-375-041-51 (UK) : H3700: UK model

TABLE OF CONTENTS

<i>Section</i>	<i>Title</i>	<i>Page</i>	<i>Section</i>	<i>Title</i>	<i>Page</i>
1. GENERAL			5-6.	Printed Wiring Boards —Main Section—	23
1-1.	Part Identification	3	5-7.	Schematic Diagram —Pin Jack Section—	27
2. DISASSEMBLY		4	5-8.	Printed Wiring Boards —Pin Jack Section—	31
3. MECHANICAL ADJUSTMENTS		6	5-9.	Printed Wiring Board	
4. ELECTRICAL ADJUSTMENTS		6	—MD Section (H3700 : UK, Germany)—	34	
5. DIAGRAMS			5-10.	Schematic Diagram	
5-1.	IC Pin Description	10	—MD Section (H3700 : UK, Germany)—	35	
5-2.	Semiconductor Lead Layouts	14	6. EXPLODED VIEWS		
5-3.	Block Diagram	15	6-1.	Cabinet Section	39
5-4.	Circuit Boards Location	18	6-2.	Cassette Holder Section	40
5-5.	Schematic Diagram —Main Section—	19	6-3.	Mechanism deck Section 1	41
			6-4.	Mechanism deck Section 2	42
			7. ELECTRICAL PARTS LIST		43

SECTION 1
GENERAL

1-1. PARTS IDENTIFICATION

This section is extracted from instruction manual.

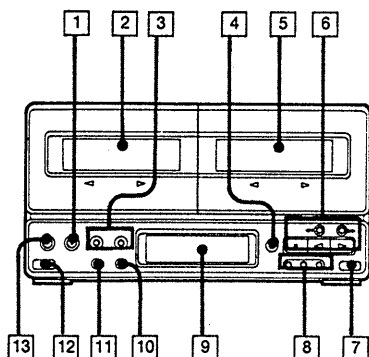

- 1 CD SYNCHRO (CD synchronized recording) button and indicator 45 48
- 2 Cassette holder (Deck A)
- 3 DECK A/B selector 30
- 4 COUNTER RESET button 30
Resets the counter of the cassette deck to "0".
- 5 Cassette holder (Deck B)
- 6 Tape operation buttons (for Deck A and B)
AMS ◀▶▶ : Fast winding
■ : Stop
▷ : Forward play
◁ : Reverse play
- 7 EJECT button (Deck B)
- 8 Tape operation buttons (for Deck B)
|| : PAUSE
○ : MUTE (Muting)
● : REC (recording)
- 9 Display window
- 10 DIRECTION MODE selector 30 33
- 11 DOLBY NR (Dolby Noise Reduction) 31
- 12 EJECT button (Deck A)
- 13 DUBBING MODE button and indicator 40

SECTION 2 DISASSEMBLY

NOTE: Follow the disassembly procedure in the numerical order given.

• FRONT PANEL

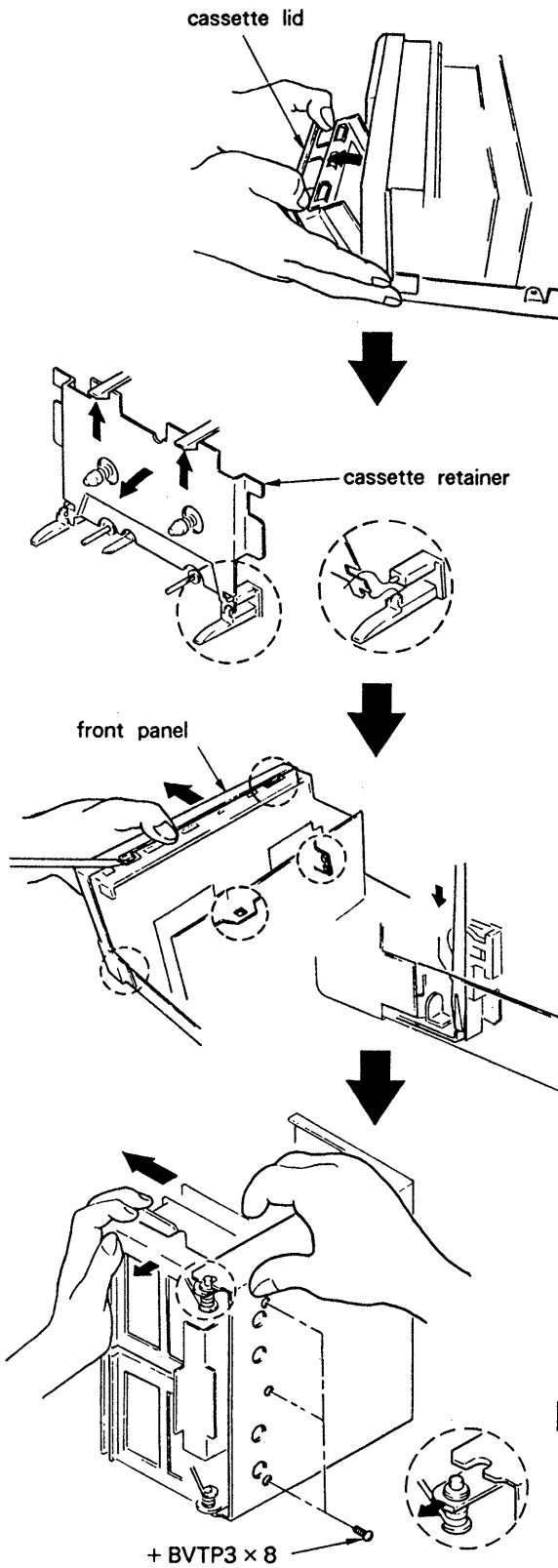

• MAIN BOARD

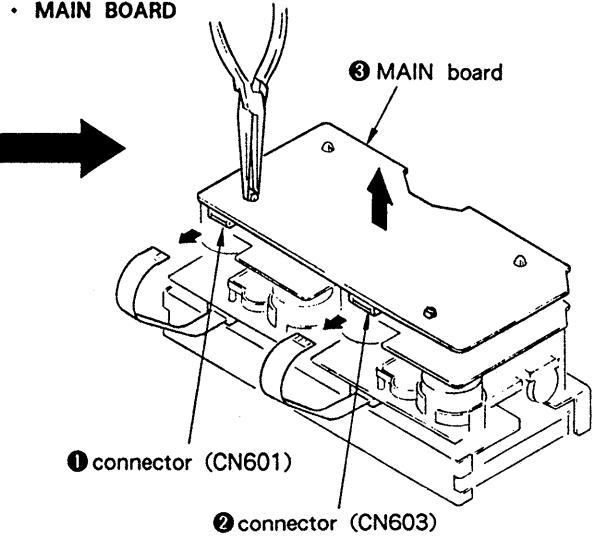

• PIN JACK/POWER BOARD

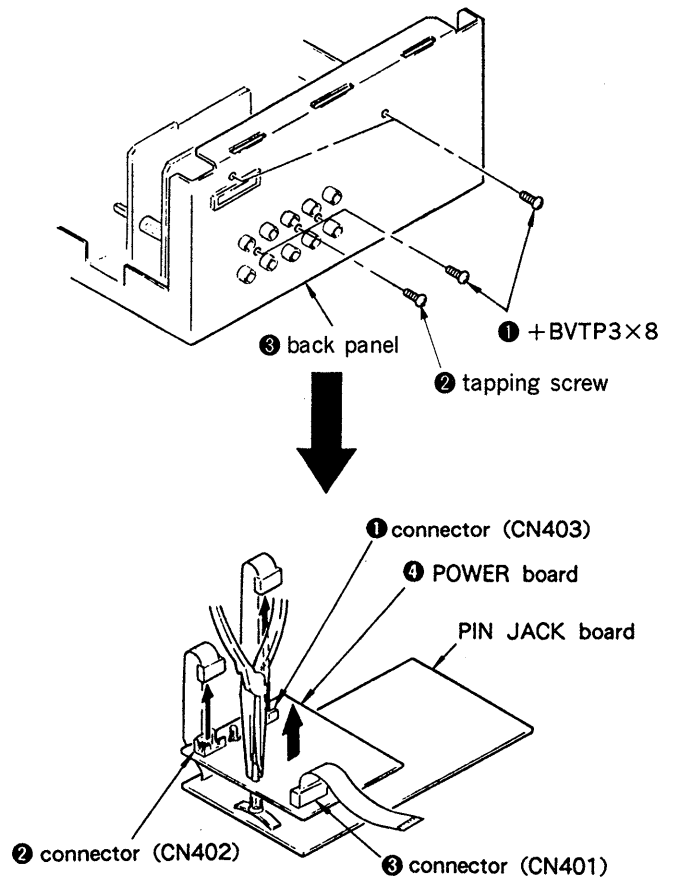

• MECHANISM DECK

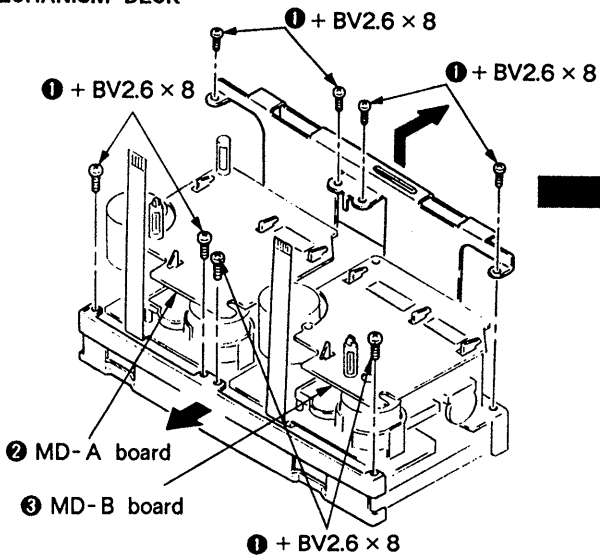

• CAPSTAN/REEL MOTOR

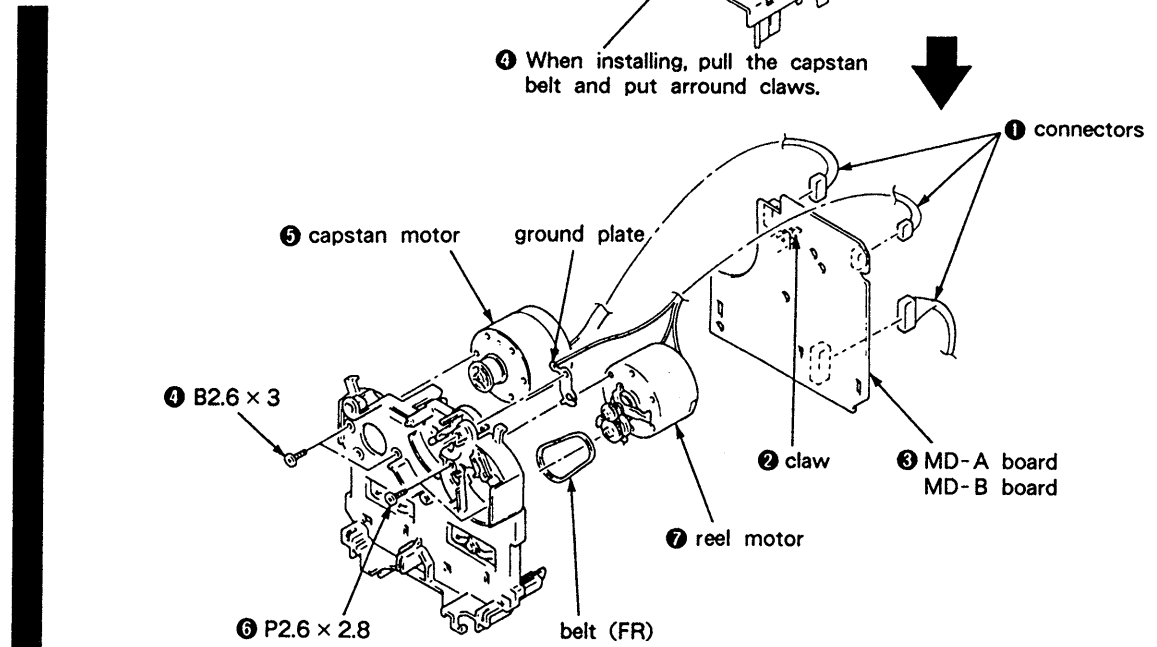
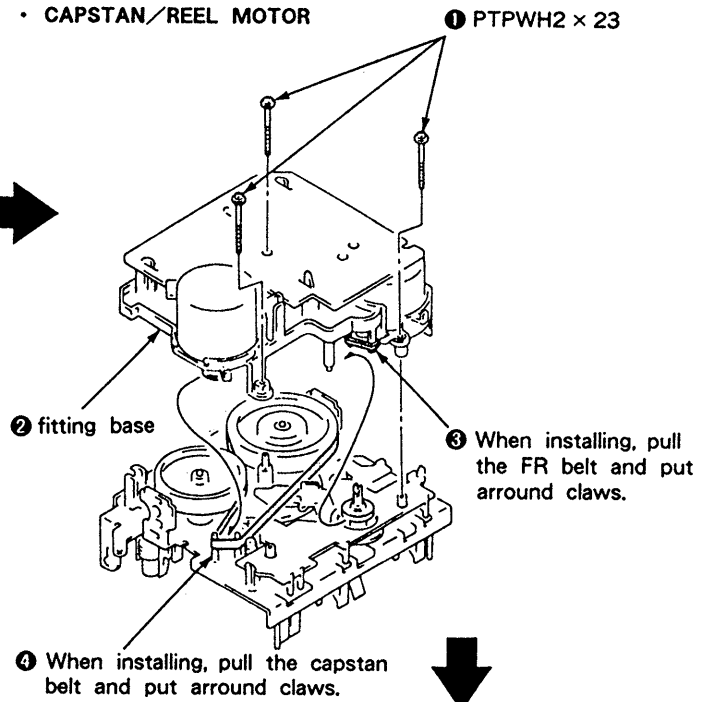

• HEAD, PINCH ROLLER

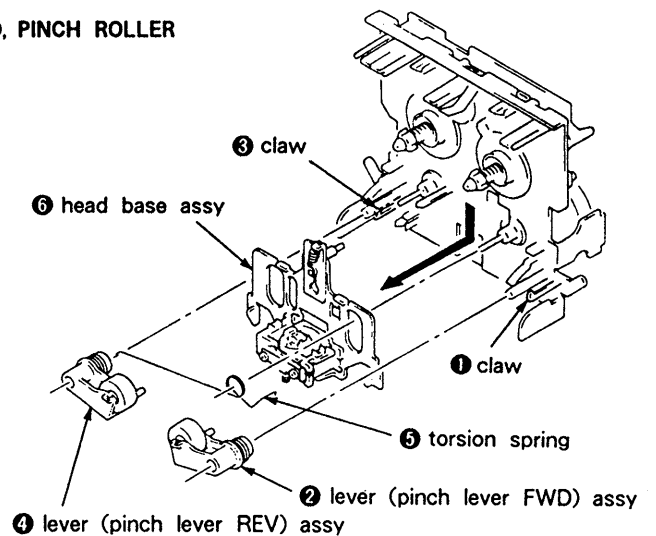

SECTION 3 MECHANICAL ADJUSTMENTS

PRECAUTION

1. Clean the following parts with a denatured alcohol-moistened swab :

record/playback head	pinch roller
erase head	rubber belts
capstan	idlers
2. Demagnetize the record/playback head with a head demagnetizer.
(Head demagnetizer do not approach for the erase head.)
3. Do not use a magnetized screwdriver for the adjustment.
4. After the adjustments, apply suitable locking compound to the parts adjusted.
5. The adjustments should be performed with the rated power supply voltage unless otherwise noted.

Torque Measurement

Torque	Torque meter	Meter reading
Forward	CQ-102C	35 to 60g · cm (0.49 to 0.83 oz · inch)
Forward back tension	CQ-102C	2 to 6g · cm (0.03 to 0.08oz · inch)
Reverse	CQ-102RC	35 to 60g · cm (0.49 to 0.83oz · inch)
Reverse back tension	CQ-102RC	2 to 6g · cm (0.03 to 0.08oz · inch)
Forward, Reverse	CQ-201B	70 to 110g · cm (0.98 to 1.52 oz · inch)

LINE IN/OUT Terminal (CNJ401)

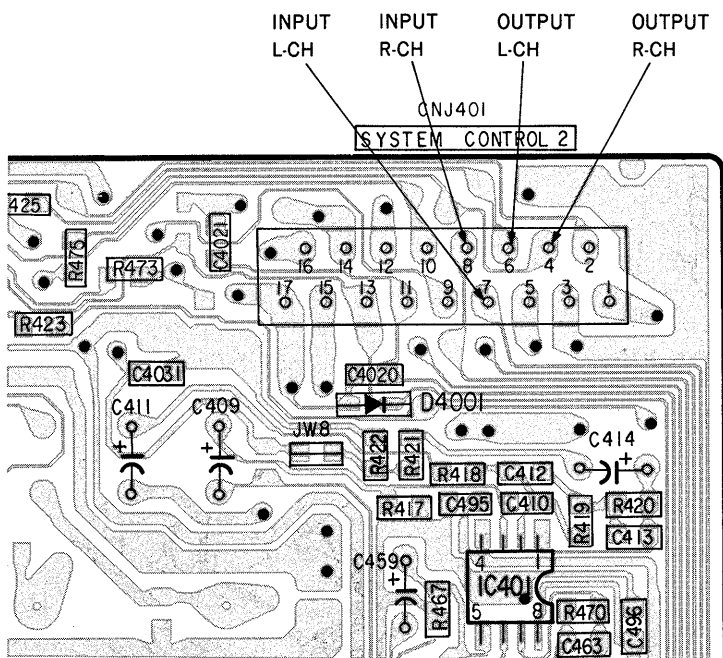

SECTION 4 ELECTRICAL ADJUSTMENTS

PRECAUTION

1. The adjustment should be performed in the publication.
(Be sure to make playback adjustment at first.)
2. The adjustment and measurement should be performed for both L-CH and R-CH.
 - Switch position
DOLBY NR switch : OFF

Test Tape

Tape	Contents	Use
P-4-A100	10kHz, -10dB	Azimuth Adjustment
P-4-L300	315Hz, 0dB	Level Adjustment
WS-48B	3kHz, 0dB	Tape Speed Adjustment

Record/Playback Head Azimuth Adjustment

DECK A **DECK B**

Procedure :

1. Forward Playback Mode
test tape
P-4-A100
(10kHz, -10dB)

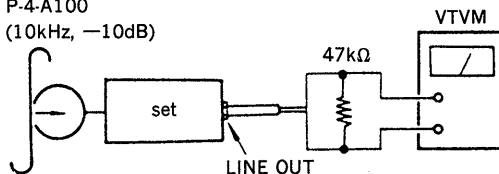

2. Turn the adjustment screw for the maximum output levels. If these levels do not match, turn the adjustment screw until both of output levels match together within 1dB.

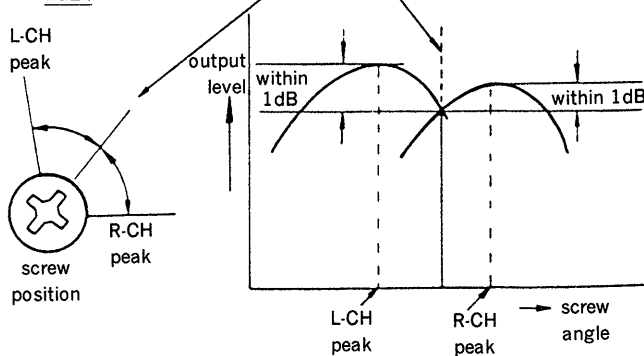

3. Playback Mode

test tape
P-4-A100
(10kHz, -10dB)

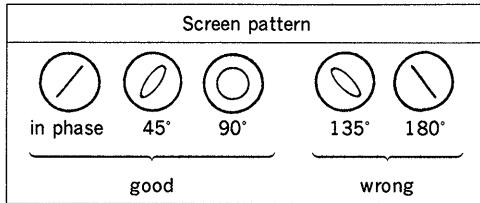
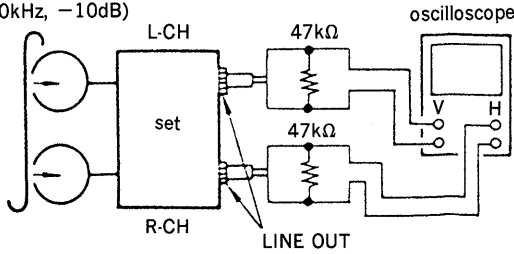

4. Change the reverse playback mode and repeat the steps 1 to 3.
5. After the adjustment, lock the adjustment screw with suitable locking compound.

Adjustment Location : —record/playback head—

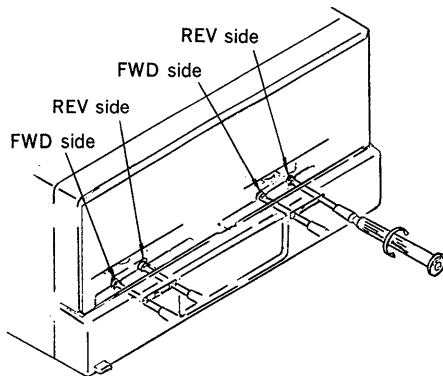
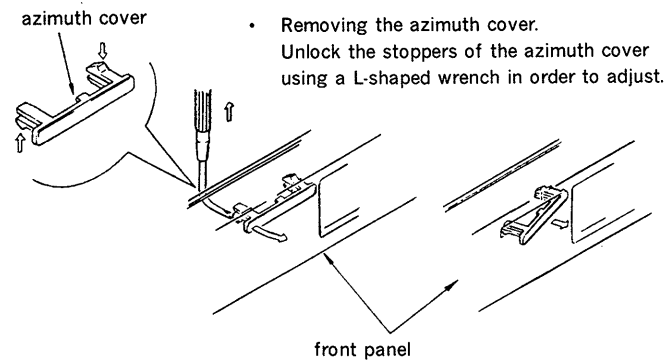

Tape Speed Adjustment DECK A DECK B

Procedure :

—Forward Playback Mode—

test tape
WS-48B
(3kHz, 0dB)

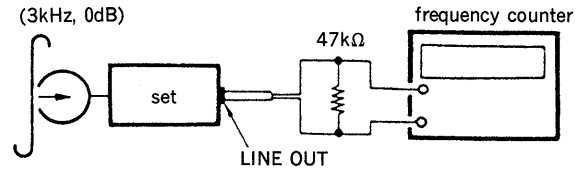

Perform high speed adjustment before normal speed adjustment.

(High speed adjustment)

1. Short TP601 (main board) when the power is OFF.
2. Turn on the power and put the deck A into the FWD mode.
3. Connect a 150Ω resistor to both the terminals of TP6001 (main board). (The set enters into high speed playback mode.)
4. Adjust RV72A (H) of the deck A so that a reading of the frequency counter meets the adjustment value.
5. Adjust the RV72B (H) of deck B performing steps 2 to 5 as deck A.
6. After the adjustment is completed, remove the short of TP601 and 150Ω resistor of TP6001.

(Normal speed adjustment)

1. Put the set into the FWD playback mode.
2. At this time, adjust RV71A (L) of the deck A and RV71B (L) of the deck B so that a reading of the frequency counter meets the adjustment value.

Adjustment Limits :

Speed	Frequency Counter Reading
High	6,000 ± 20Hz
Normal	3,000 ± 10Hz

Frequency difference between the beginning and the end of the tape should be within 3%.

Frequency difference between deck A and deck B the beginning of the tape should be within 1.5%.

Adjustment Location : MD-A Board

MD-B Board (H2700, H3700 : AEP)

MD-B HX PRO Board

(H3700 : UK, Germany)

Playback Level Adjustment DECK A DECK B

Procedure :

—Forward Playback Mode—

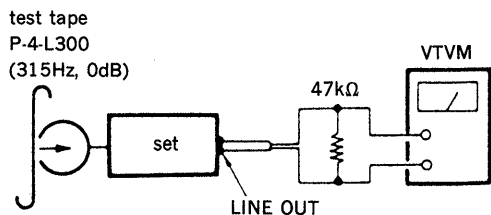

Adjust deck A : RV11A (L-CH), RV21A (R-CH) and deck B : RV11B (L-CH), RV21B (R-CH) so that the VTVM reading becomes the adjustment limits below.

Adjustment Limits :

LINE OUT level : $-10 \pm 0.5\text{dB}$ (0.23 to 0.26V)

Level Difference between Channels : within 0.5dB

Confirm the LINE OUT level does not change in playback mode while changing the mode from playback to stop several times.

Adjustment Location : MD-A Board
 MD-B Board (H2700, H3700 : AEP)
 MD-B HX PRO Board
 (H3700 : UK, Germany)

Tape Speed/playback Level Adjustment

Screwdriver to adjust the MD block

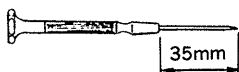

The MD block adjustment can be performed by inserting a screwdriver of which axis length (not including the shaft) is 35 mm or more through the rear side of the main board.

MD-B Board (H2700, H3700 : AEP)
 MD-B HX PRO Board (H3700 : UK, Germany)

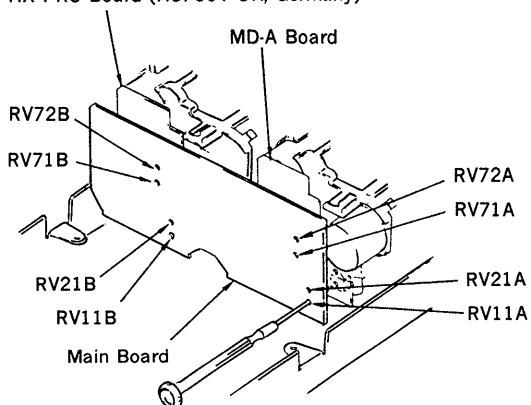

Record Bias Adjustment DECK B

Procedure :

1. Record Mode

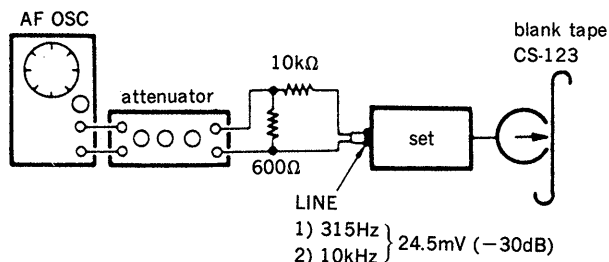

2. Playback Mode

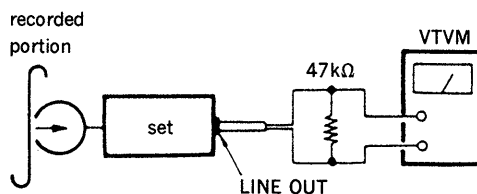

Playback the signal recorded in step 1.

Confirm that the 10kHz playback output is $0 \pm 0.5\text{dB}$ (0.732 to 0.821V) relative to the 315Hz output. if necessary, adjust RV12 (L-CH), RV22 (R-CH) (MD-B board (H2700, H3700 : AEP)) or RV81 (L-CH), RV91 (R-CH) (MD-B HX PRO board (H3700 : UK, Germany)) and repeat the steps given above.

Adjustment Location : MD-B Board (H2700, H3700 : AEP)
 MD-B HX PRO Board
 (H3700 : UK, Germany)

Record Level Adjustment DECK B

Procedure :

1. Record Mode

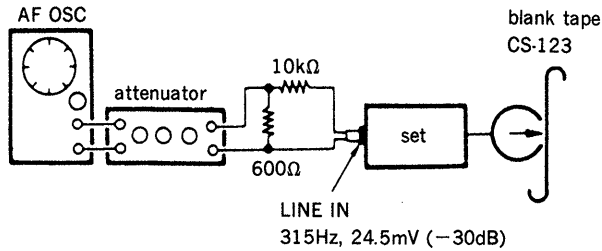

2. Playback Mode

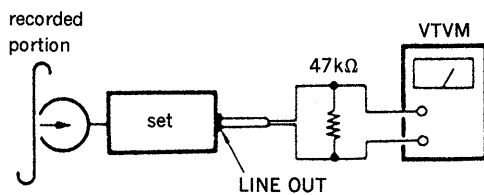

Confirm playback the tape recorded become adjustment level as follows.

If necessary, adjust RV101 (L-CH), RV201 (R-CH) and repeat steps 1 and 2.

Adjustment Limits :

LINE OUT level : $-30 \pm 0.5\text{dB}$ (23 to 26mV)

Adjustment Location : main board

Adjustment Location :

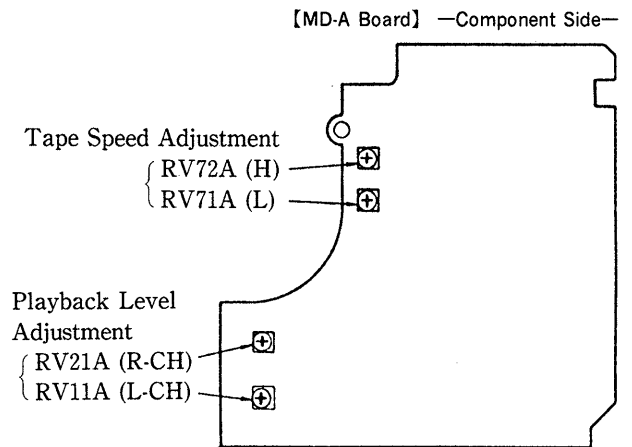

【MD-B Board】 (H2700, H3700: AEP)
【MD-B HX PRO Board】 (H3700: UK, Germany)
—Component Side—

Record Bias Adjustment

- RV12 (H2700, H3700: AEP) (L-CH)
- RV81 (H3700: UK, Germany) (L-CH)
- RV22 (H2700, H3700: AEP) (R-CH)
- RV91 (H3700: UK, Germany) (R-CH)

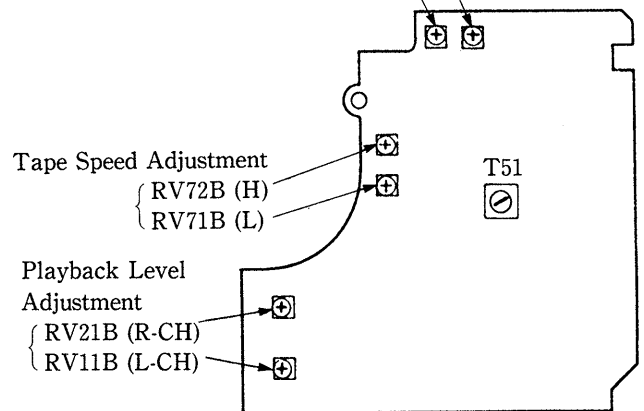

【Main Board】 —Component Side—

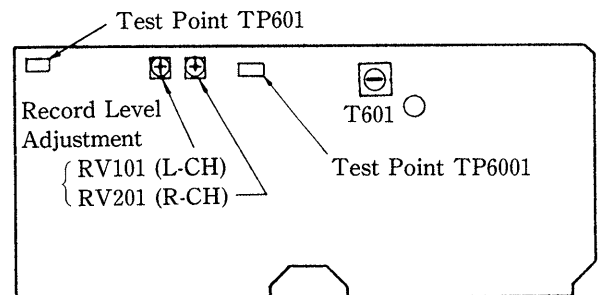

SECTION 5 DIAGRAMS

5-1. IC PIN DESCRIPTION

IC351 display microprocessor HD614023-FA93

Fluorescent indicator tube is activated by receiving data from IC601 (system controller).

Pin No.	Pin Name	I/O	Description
1—11	S10—S0	O	FL indicator tube (FL351) segment output
12			Not used. (+5.6V)
13	VDISP	—	Power supply for activating the FL indicator tube (−20V)
14—15			Not used (GND)
16	SYNC	I	Interrupt input. Data transmission from IC601 (system controller) is checked.
17	INT	I	Not used. (GND)
18—25		I	Not used. (GND)
26	V _{CC}	—	Power supply terminal (+5.6V)
27	CLK	I	Data transmission clock input from IC601 (system controller)
28	DATA	I	Serial data input from IC601 (system controller)
29	SYNC	I	Sync signal input which indicates the first byte of data sent from IC601 (system controller)
30		—	Not used. (GND)
31	KEY A	O	LED (D303) light output in the deck A.
32	KEY B	O	LED (D304) light output in the deck B.
33	HIGH DUB	O	LED (D301) light output in the high speed dubbing mode.
34	NORM DUB	O	LED (D301) light output in the normal speed dubbing mode.
35	CD SYNC	O	LED (D302) light output in the CD synchro mode.
36—38			Not used. (GND)
39	FLCHECK	I	All the FL indicator tubes are lit when this port is set to “L”. (Normally +5.6V)
40—42			Not used. (GND)
43	RESET	I	Reset input from IC601 (system controller). “L”: Reset.
44	TEST	I	Not used. (+5.6V)
45	OSC1	I	Clock input (4.19MHz)
46	OSC2	O	Clock output
47	GND	—	Power supply terminal (GND)
48—50			Not used. (GND)
51			Not used. (Pull-up)
52—57	G0—G6	O	FL indicator tube (FL351) grid output
58—61			Not used. (+5.6V)
62—64	S11—S13	O	FL indicator tube (FL351) segment output

IC406 selector controller M50760-315FP

AV output is switched with the audio pass signal sent from the amplifier (TA-H2700/H3700).

Pin No.	Pin Name	I/O	Description
1	D3	I	Model selection input port. Connected to GND.
2	A0	O	Audio IN switch (IC403 and IC404) control output port.
3			Not used.
4	A1	O	Audio IN switch (IC403 and IC404) control output port.
5	CNV _{SS}	—	Power supply terminal (GND)
6	V _{SS}	—	Power supply terminal (GND)
7	A2	O	Audio IN switch (IC403 and IC404) control output port.
8	B0	O	Audio OUT switch (IC405) control output port.
9	B1	O	Audio OUT switch (IC405) control output port.
10			Not used.
11, 12			Not used.
13, 14			Not used. (GND)
15			Not used.
16	RESET	I	Reset input. “L”: Reset
17	XOUT	O	Clock output.
18	XIN	I	Clock input.
19	S	I	Serial data input (audio bus)
20	D2	I	Serial data input (audio bus)
21	S1	I	Model selection input port. Connected to GND.
22			Not used.
23	VD0	I	Model selection input port. Connected to GND.
24	V _{DD}	—	Power supply terminal (+5V)

IC601 system controller M50944-128FP

The system is wholly controlled by communication between IC351 (display microprocessor) and IC602 (mechanism controller).

Pin No.	Pin Name	I/O	Description
1	KEY2	I	Not used. (GND)
2	KEY1	I	Not used. (GND)
3	SYNC	O	Synchro signal input which indicates the first byte of data sent to IC351 (display microprocessor).
4	FL-SCK	O	Data transmission clock output to IC351 (display microprocessor).
5	FL-SO	O	Serial data output to IC351 (display microprocessor).
6	AU-BUS	O	Audio pass output.
7	AU-BUS	I	Audio pass input (negative edge).
8	POWER-IN	I	Power-off detection input. "L": Power OFF.
9	PB-SELECT	O	Deck A/B switch output in the playback mode. "L": deck B, "H": deck A.
10	AMS-SELECT	O	AMS amplifier input switch output
11	MD-REQ	I	Data request input from IC602 (mechanism controller)
12	MD-SCLK	O	Data transmission clock output to IC602 (mechanism controller)
13	MD-SO	O	Serial data output to IC602 (mechanism controller)
14	MD-SI	I	Serial data input from IC602 (mechanism controller)
15		O	Not used. (GND)
16	RESET (MD)	O	IC602 (mechanism controller) reset signal output.
17	AU-BUS	I	Audio bus input (positive-edge)
18	RESET (DSP)	O	IC351 (display microprocessor) reset signal output.
19	GND	—	Power supply terminal. (GND)
20	RESET	I	System reset input. "L": Reset.
21	X-IN	I	Clock input (4MHz)
22	X-OUT	O	Clock output
23	XC-IN	I	Not used. (GND)
24	XC-OUT	O	Not used. (open)
25	VSS	—	Power supply terminal (GND)
26	N. C.		Not used. (open)
27	TEST	I	Electrical adjustment test mode setting input This set enters into the test mode when the power is on and it is set to "L". * 1
28	VAR SELECT	I	Not used. (pull-up)
29	METAL (B)	I	Metal switch (S83) input for deck B. "H": Metal.
30	70 μ (B)	I	Chrome switch (S82) input for deck B. "L": Normal.
31	PPOWER-ON	O	Not used. (open)
32—35			Not used. (GND)
36	70 μ (A)	I	Chrome switch (S83) input for deck A. "L": Normal.
37	AMS IN	I	Signal input from the AMS amplifier. "H": Detected, "L": Not detected.
38	N. C.		Not used. (GND)
39			Not used. (GND)
40	EQ-HIGH	O	REC equalizer characteristic switch output "H": High speed, "L": Normal speed.
41	BIAS FADE	O	Not used. (GND)
42	BIAS (B)	O	Bias ON/OFF switch output. "H": OFF, "L": ON.
43	TYPE II (B)	O	Not used. (GND)
44	TYPE I (B)	O	Not used. (GND)
45	R.MUTE (B)	O	REC mute control output. "L": Mute ON, "H": Mute OFF.
46	RELAY (B)	O	Mechanism deck head switch control output. "L": ON.
47	DOLBY B	O	Dolby B/C switch control output. "L": Dolby C, "H": Dolby B.
48	DOLBY ON	O	Dolby ON/OFF switch control output. "L": ON, "H": OFF.
49	REC/PB	O	Dolby amplifier REC/PB switch output. "L": REC, "H": PB.
50			Not used. (open)
51	PB 70 μ	O	Playback equalizer characteristic switch output. "H": normal, "L": chrome/metal.
52	AMS/BS	O	Not used.
53	PASS	O	PASS amplifier switch output for LINE OUT. "L": PASS amplifier, "H": Through.

Pin No.	Pin Name	I/O	Description
54	LINE-MUTE	O	Line mute control output. "L": MUTE OFF, "H": MUTE ON
55	AVCC	—	Power supply terminal. (+5V)
56	VCC	—	Power supply terminal. (+5V)
57	AVSS	—	Power supply terminal (GND)
58	V.REF	I	Reference voltage input for A/D input port (+5V)
59	METER (R)	I	Level meter signal input (R-CH)
60	METER (L)	I	Level meter signal input (L-CH)
61	VOL DATA	I	Not used. (GND)
62	KEY5	I	Not used. (GND)
63	KEY4	I	Key input. (analog) * 2
64	KEY3	I	Key input. (analog) * 2

* 1 Test mode

When the power is on and pin ② is set to "L" Short TP601. (main board), the set enters the electrical adjustment test mode and the followings can be available.

(1) High speed playback

When deck A or B is in the playback mode and a 150Ω resistor is connected to both the terminals of TP6001 (main board), the set can be entered the high speed playback mode.

(2) Source monitor

Recording signals can be monitored through the LINE OUT terminal (see page 6.) because the line short is removed in recording.

(3) Recording memory

Recording memory is set to ON when the tape counter is reset at the record start point.

(4) Mode display

The counter displays as shown in the figure A when the counter mode is set to the deck A and the deck A button of deck A/B switch is pressed, or when the counter mode is the deck B and the deck B button is pressed.

(5) When this terminal is set back to "H" after it is set to the test mode in "L" of the power-on mode, all the FL indicator tubes are lit.

(The mechanism block continues to operate as before it is set to "H".)

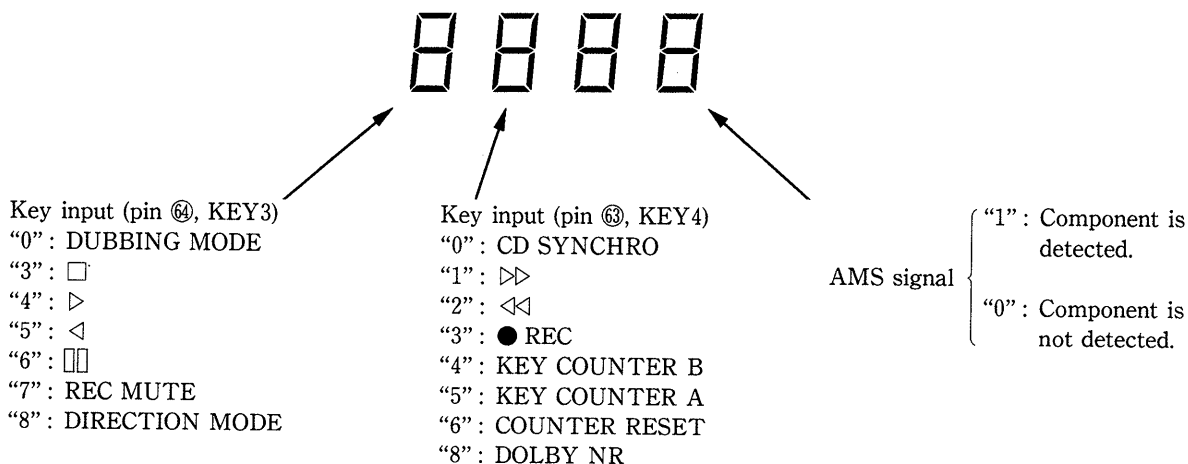

Figure A

* 2 Key input (analog port)

Input port \ Voltage(V)	0	0.3	0.7	1.2	1.7	2.3	2.8	3.3	4.0
Pin ③, KEY4	CD SYNCHRO	◁◁	▷▷	● REC	KEY COUNTER B	KEY COUNTER A	COUNTER RESET		DOLBY NR
Pin ④, KEY3	DUBBING MODE			□	▷	◁	□□ PAUSE	● REC MUTE	DIRECTION MODE

5-2. SEMICONDUCTOR LEAD LAYOUTS

BA3308F
CD4066BCM

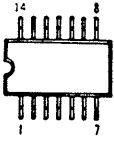

(TOP VIEW)

BA7625
HD14053BFP

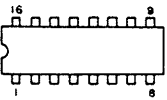

(TOP VIEW)

CD4052BCM
CXA1578M
MC14051BF

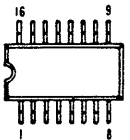

(TOP VIEW)

CXA1331M

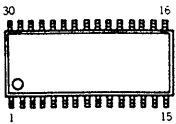

(TOP VIEW)

HD614023-FA93
M50944-128FP

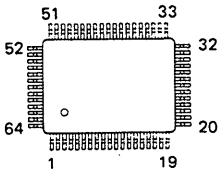

(TOP VIEW)

LA5603-S

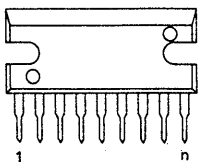

M50760-315FP

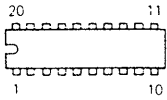

(TOP VIEW)

M50925-482FP

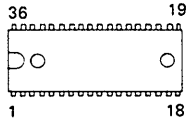

(TOPVIEW)

M51953BFP
μPC4570G2

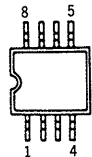

(TOP VIEW)

M5218AFP

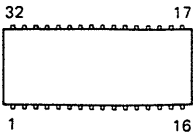

TA7272P

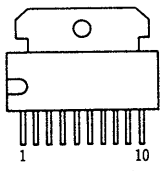

marking side view

μPC1297CA

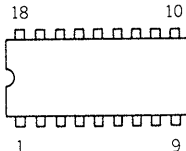

(TOP VIEW)

FA1A4M-L33
FA1A4Z-L68
2SA1162
2SA1602-F
2SC3395
2SC4154-F

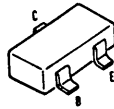

2SA1341

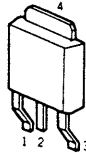

2SA1344

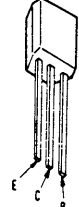

2SB1094-LK
2SD2012

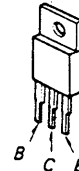

2SB1122-S
2SD1622-S

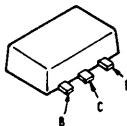

DCA010

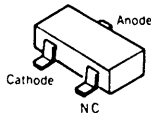

EC10DS2
EC10QS-04

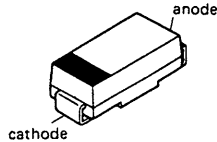

MA8056
1SS352

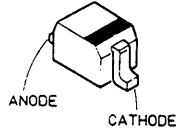

NJL5165K-B

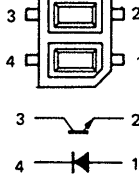

UZM8.2Z

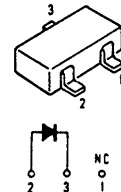

SEL4226C
SEL4226E

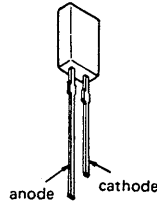

5-3. BLOCK DIAGRAM

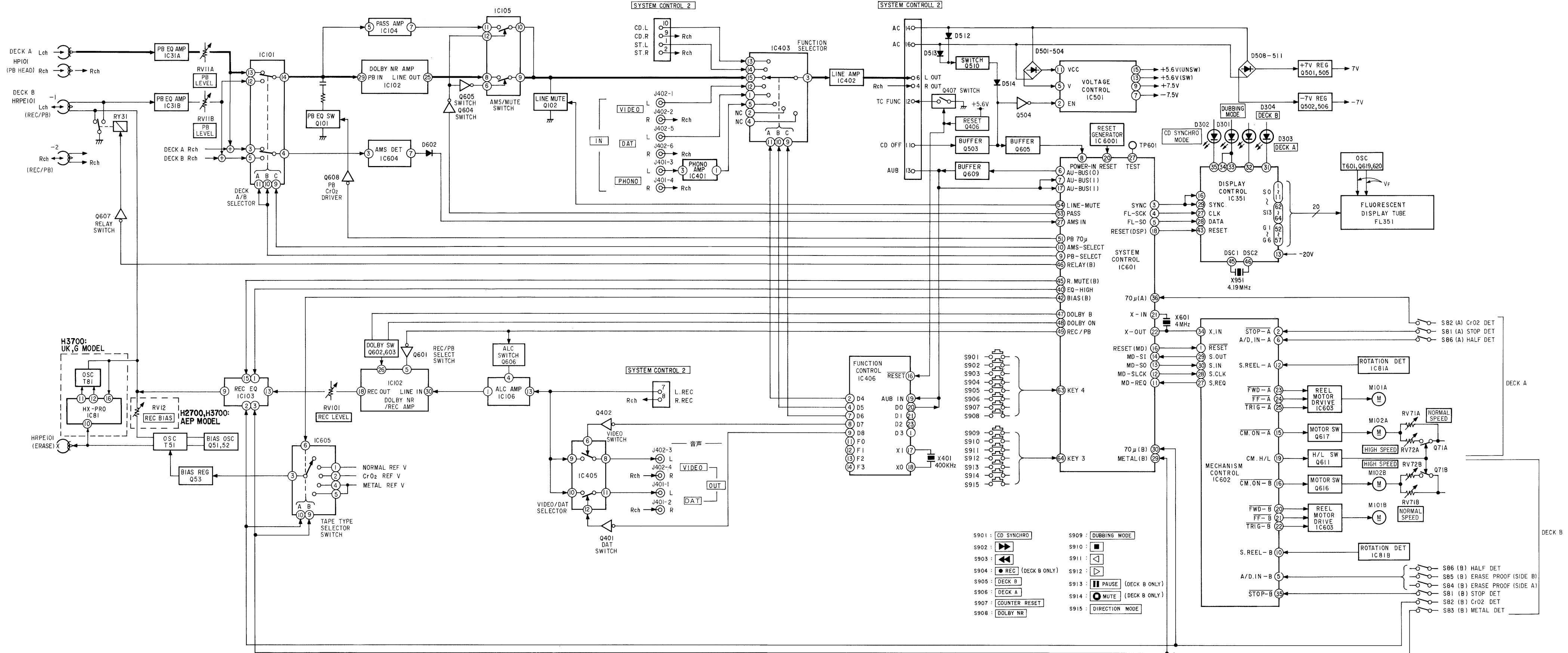

5-4. CIRCUIT BOARDS LOCATION

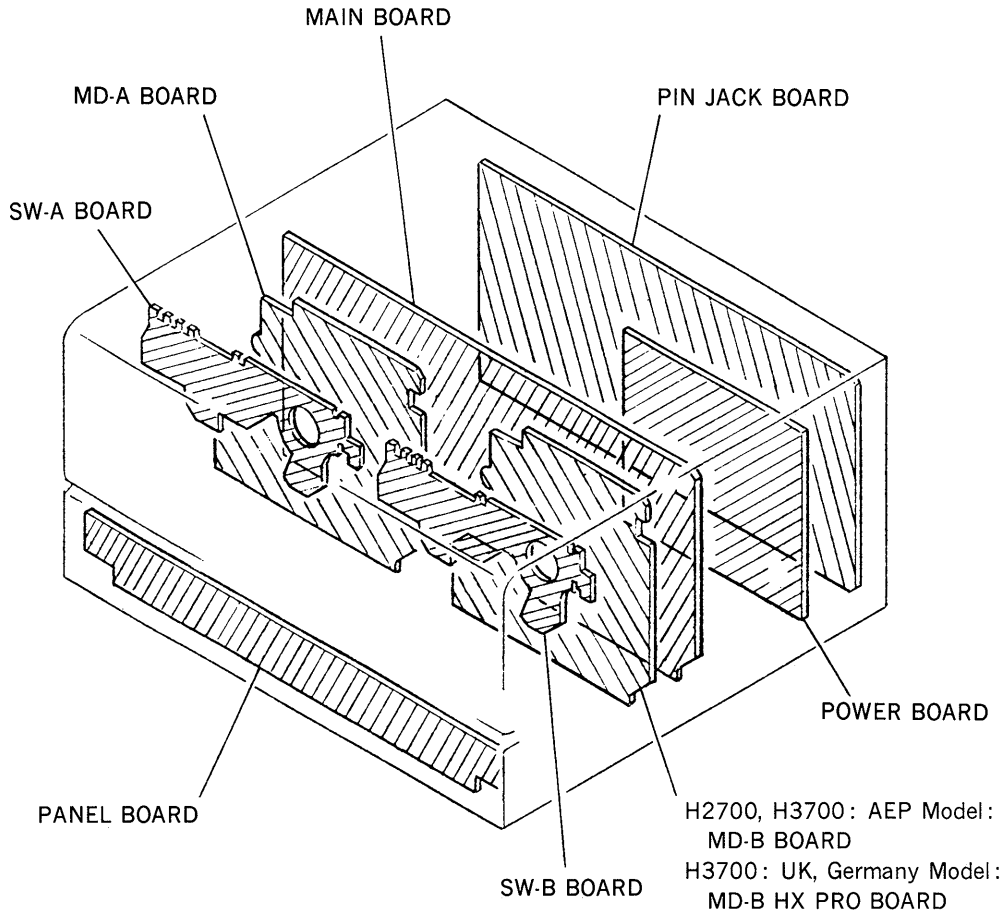

5-5. SCHEMATIC DIAGRAM —MAIN SECTION— Refer to page 37 for IC Block Diagrams.

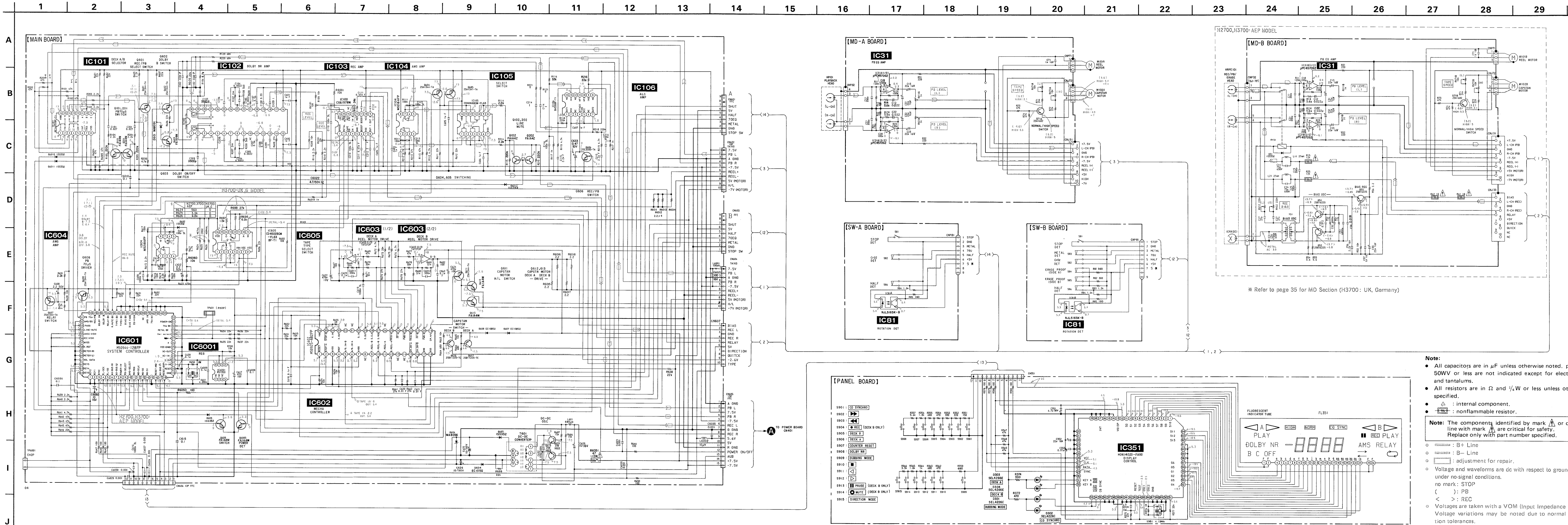

- Note:**
- All capacitors are in μF unless otherwise noted. pF : μF 50WV or less are not indicated except for electrolytics and tantalums.
 - All resistors are in Ω and $\frac{1}{4}\text{W}$ or less unless otherwise specified.
 - \triangle : internal component.
 - \square : nonflammable resistor.
- Note:** The components identified by mark \triangle or dotted line with mark \triangle are critical for safety. Replace only with part number specified.
- : B+ Line
 - : B- Line
 - : adjustment for repair.
 - Voltage and waveforms are dc with respect to ground under no-signal conditions.
no mark: STOP
(): PB
< > : REC
 - Voltages are taken with a VOM (Input Impedance $10\text{M}\Omega$). Voltage variations may be noted due to normal production tolerances.
 - Signal path.
 - ⊞ : PB (DECK A)
 - ⊞ : REC (DECK A)
 - ⊞ : REC (DECK B)
 - ⊞ : REC (DECK A)
 - G: Germany model

5-6. PRINTED WIRING BOARDS —MAIN SECTION— • Refer to page 14 for Semiconductor Lead Layouts.

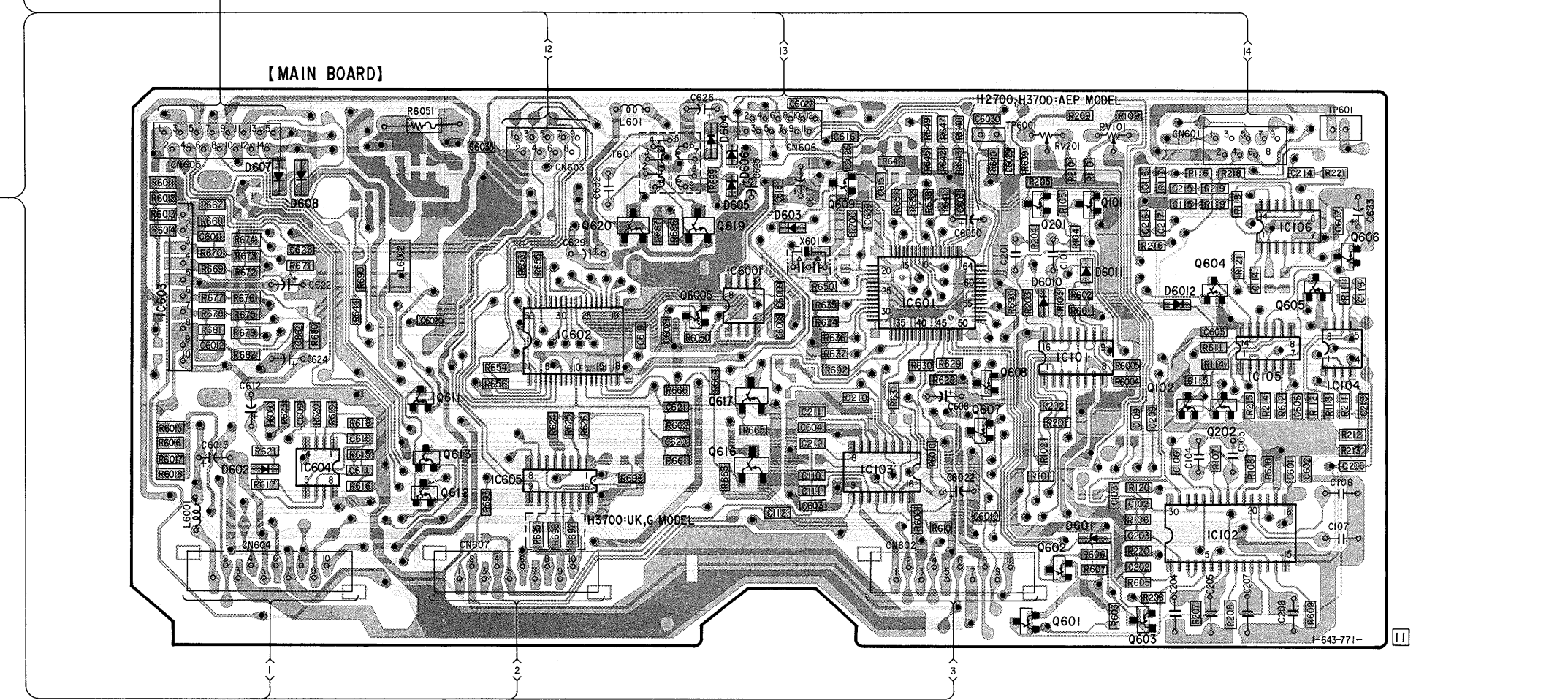
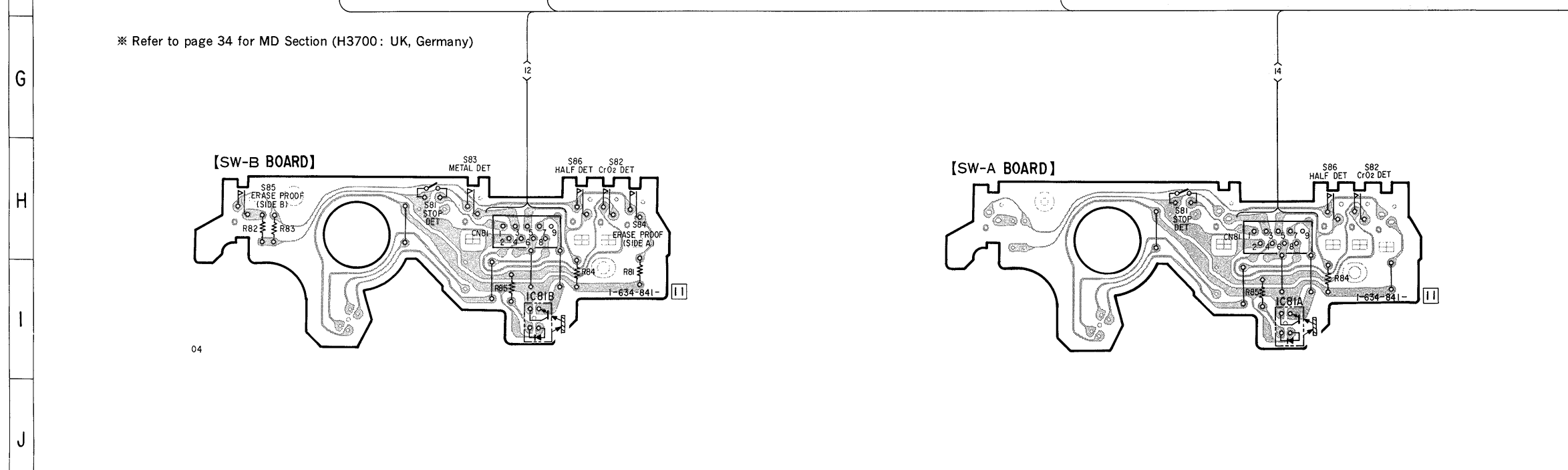
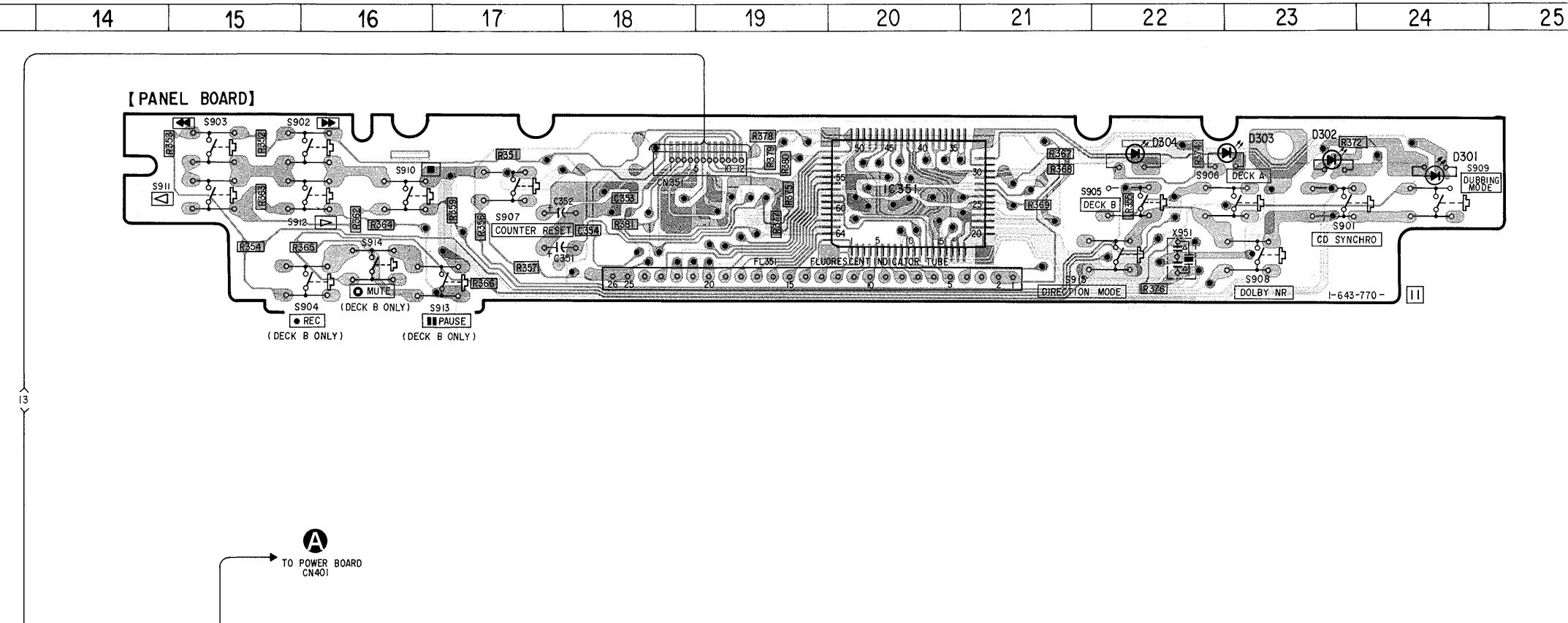
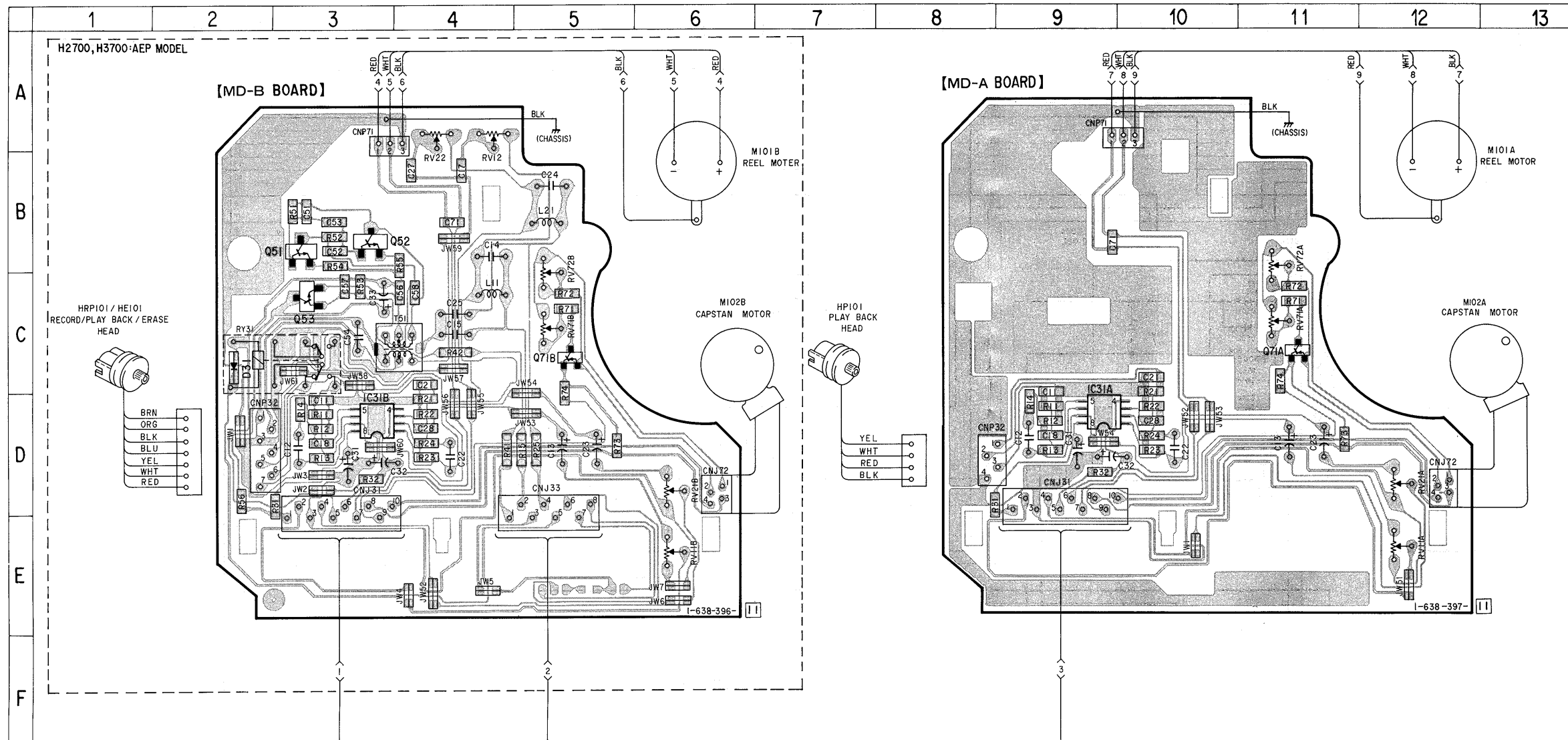

• Semiconductor Location

Ref. No.	Location
D31	C-2
D301	B-24
D302	A-23
D303	A-22
D304	A-22
D601	I-21
D602	I-15
D603	G-19
D604	F-19
D605	F-19
D606	F-19
D607	F-15
D608	F-15
D6010	G-21
D6011	G-21
D6012	G-22
IC31A	D-9
IC31B	D-3
IC81A	I-11
IC81B	I-5
IC101	H-21
IC102	I-22
IC103	I-20
IC104	H-23
IC105	H-23
IC106	G-23
IC351	B-20
IC601	G-20
IC602	H-17
IC603	G-15
IC604	I-16
IC605	I-17
IC6001	G-19
Q51	B-3
Q52	B-3
Q53	C-3
Q71A	C-11
Q71B	C-5
Q101	G-21
Q102	H-22
Q201	G-21
Q202	H-22
Q601	J-21
Q602	I-21
Q603	J-22
Q604	G-22
Q605	G-23
Q606	G-23
Q607	H-21
Q608	H-21
Q609	F-20
Q611	H-16
Q612	I-16
Q613	H-16
Q616	H-19
Q617	H-19
Q619	G-18
Q620	G-18
Q6005	G-18

Note:
 ○ : parts extracted from the component side.
 ● : Through hole.
 ◐ : Pattern on the side which is seen.
 ◑ : Pattern of the rear side.
 ●G : Germany model

5-7. SCHEMATIC DIAGRAM —PIN JACK SECTION— Refer to page 37 for IC Block Diagrams.

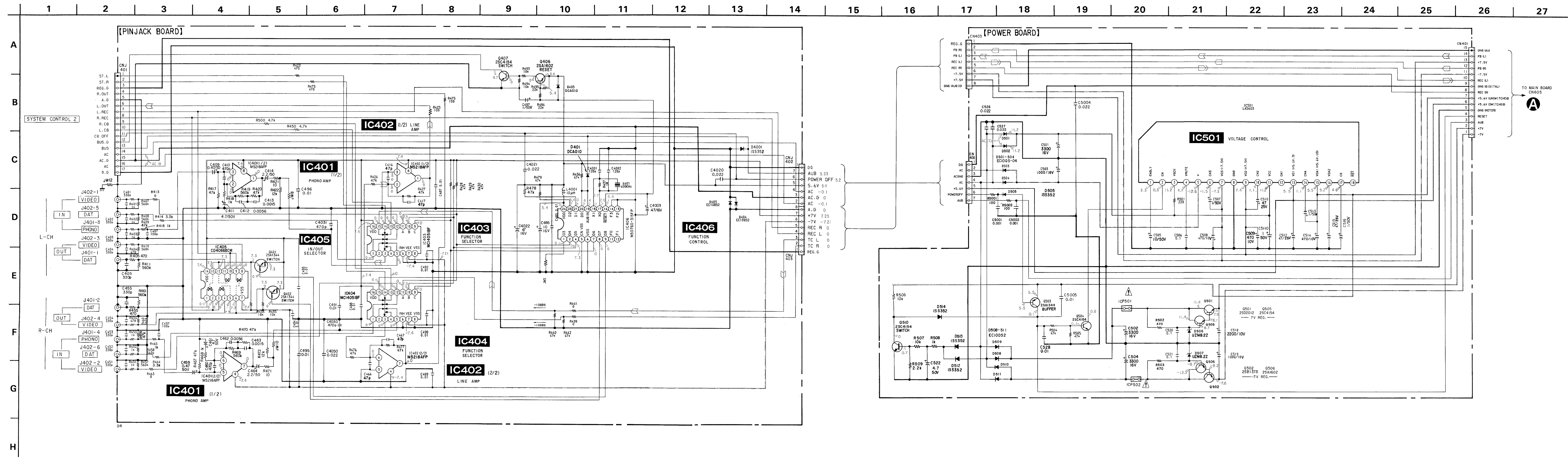

- Note:**
- All capacitors are in μF unless otherwise noted. pF : μpF 50WV or less are not indicated except for electrolytics and tantalums.
 - All resistors are in Ω and $\frac{1}{4}\text{W}$ or less unless otherwise specified.
- Note:** The components identified by mark **A** or dotted line with mark **A** are critical for safety. Replace only with part number specified.
- : B+ Line
 - : B- Line
 - : Voltage and waveforms are dc with respect to ground under no-signal conditions.
 - : no mark: STOP
 - : (): PB
 - : < >: REC
 - : Voltages are taken with a VOM (Input Impedance 10M Ω). Voltage variations may be noted due to normal production tolerances.
 - **Signal path.**
 - : PB (DECK A)
 - : REC (DECK A)
 - : REC (DECK B)

5-9. PRINTED WIRING BOARD —MD SECTION (H3700: UK, Germany)—

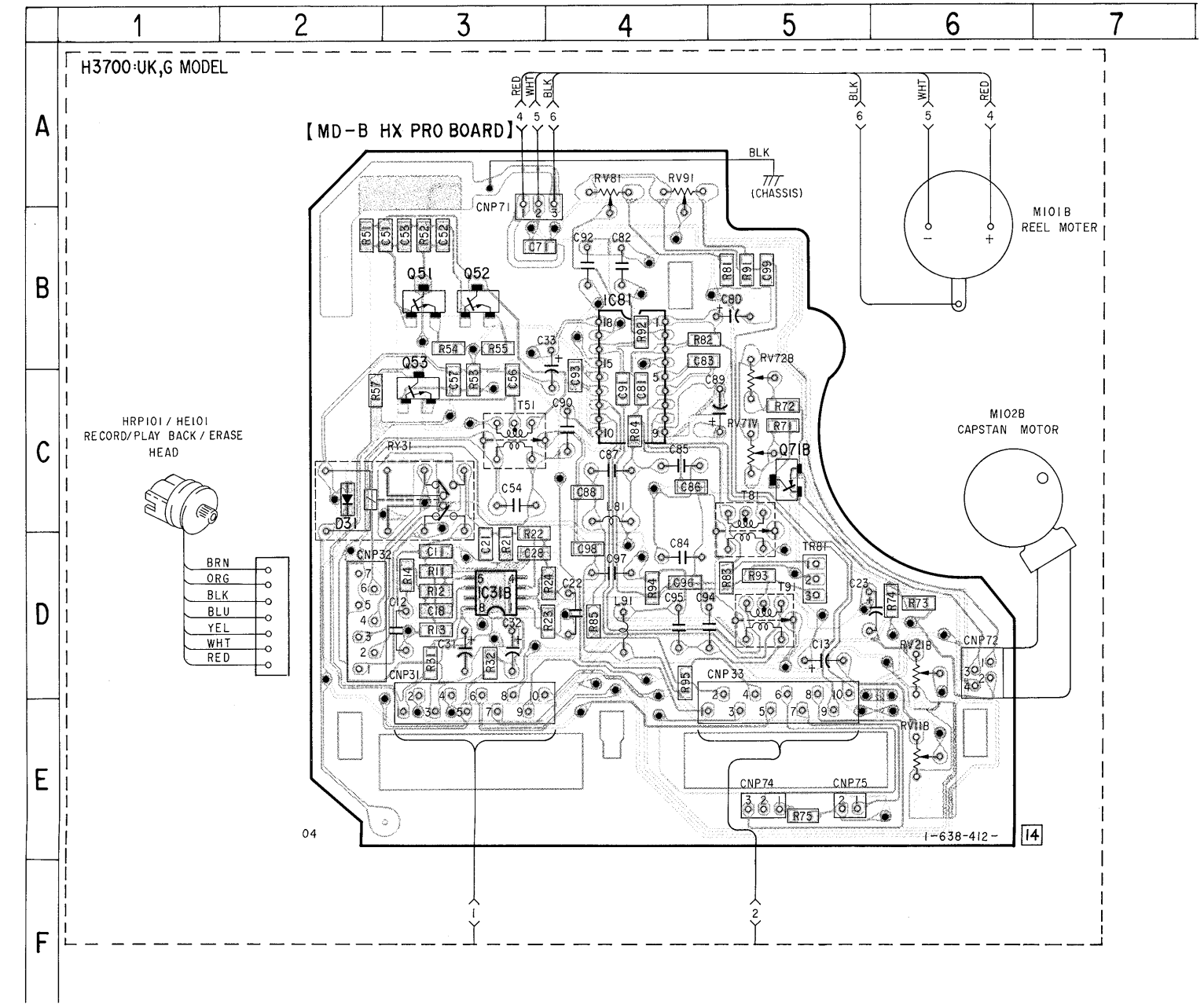

● Semiconductor Location

Ref. No.	Location
D31	C-2
IC31B	D-3
IC81	B-4
Q51	B-3
Q52	B-3
Q53	C-3
Q71B	C-5

- Note:
- — : parts extracted from the component side.
 - : Through hole.
 - ▨ : Pattern on the side which is seen.
 - (with diagonal lines) : Pattern of the rear side.
 - G : Germany model

5-10. SCHEMATIC DIAGRAM —MD SECTION (H3700: UK, Germany)—

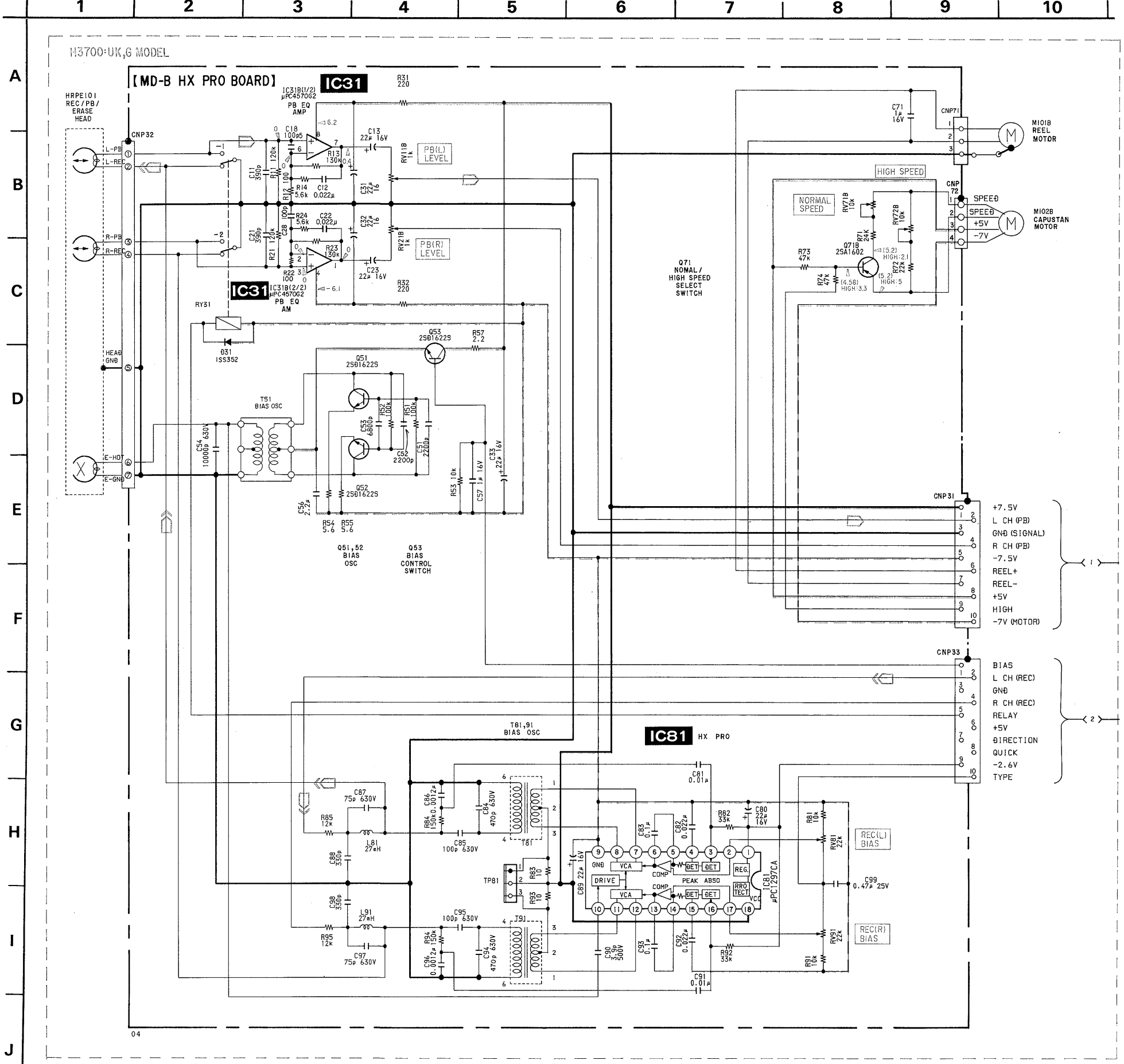

- Note:
- All capacitors are in μF unless otherwise noted. pF : μF 50WV or less are not indicated except for electrolytics and tantalums.
 - All resistors are in Ω and $\frac{1}{4}\text{W}$ or less unless otherwise specified.
 - : B+ Line
 - : B- Line
 - (with diagonal lines) : adjustment for repair.
 - Voltage and waveforms are dc with respect to ground under no-signal conditions.
 - no mark : STOP
 - Voltages are taken with a VOM (Input Impedance $10\text{M}\Omega$). Voltage variations may be noted due to normal production tolerances.
 - Signal path.
 - ▨ : PB (DECK B)
 - ▨ (with diagonal lines) : REC (DECK B)
 - G : Germany model

● IC Block Diagrams

IC102 CXA1331M

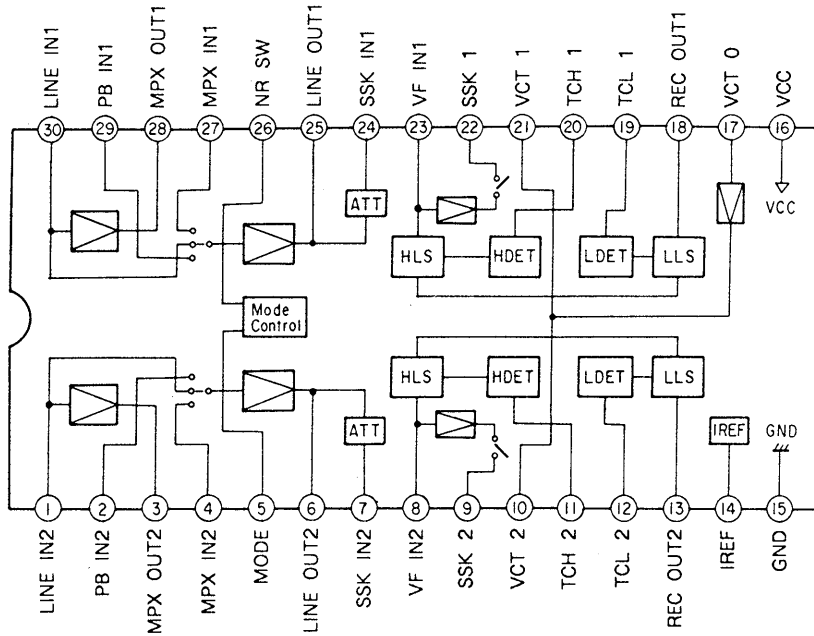

IC103 CXA1578M

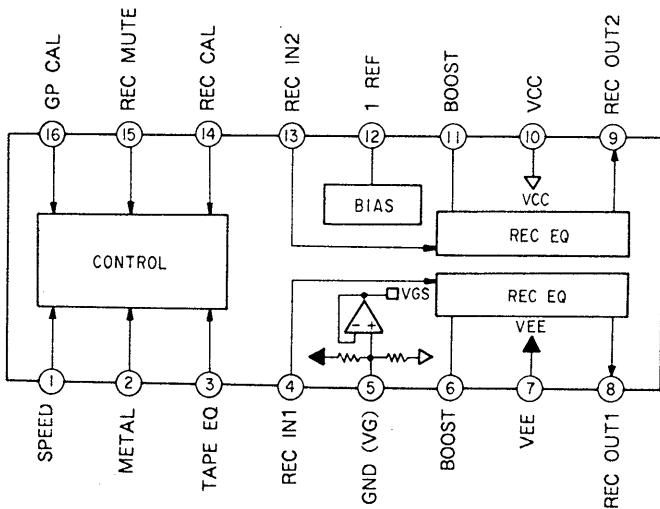

IC407 BA7625

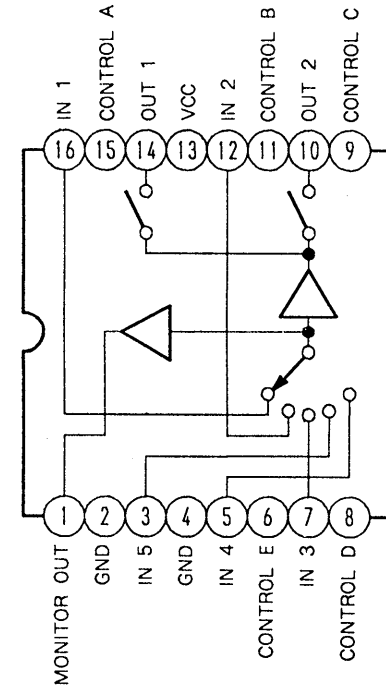

IC106 BA3308F

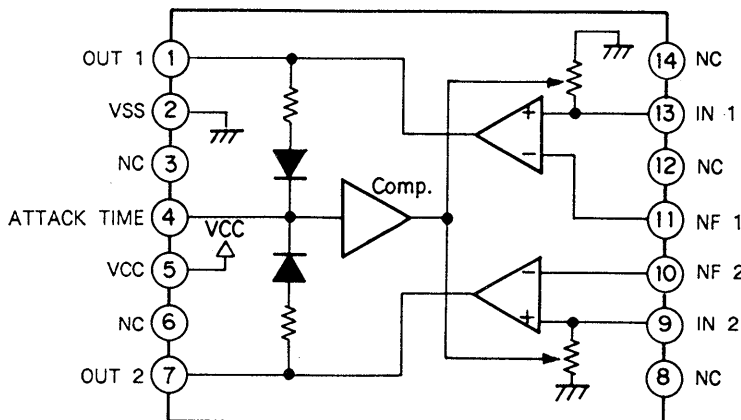

IC501 LA5603-S

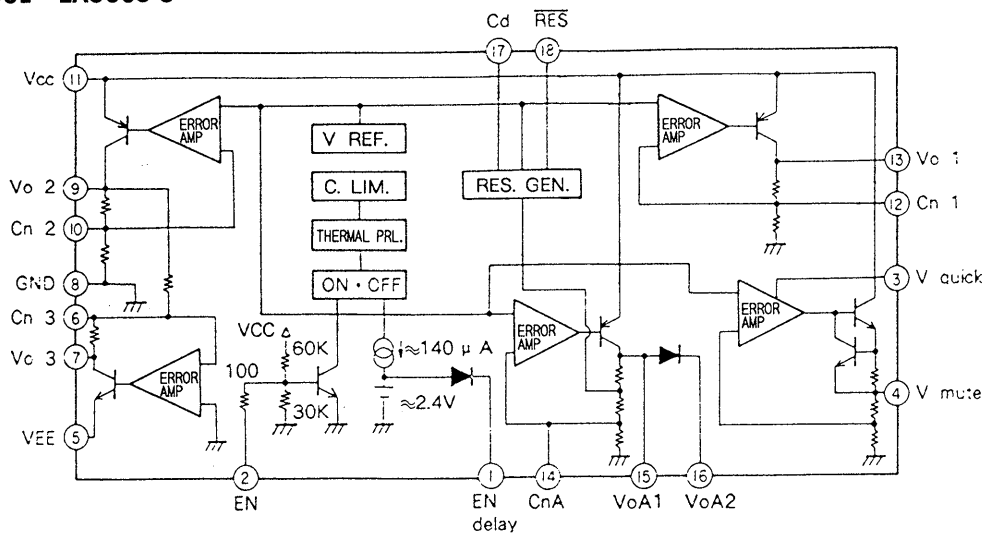

6-2. CASSETTE HOLDER SECTION

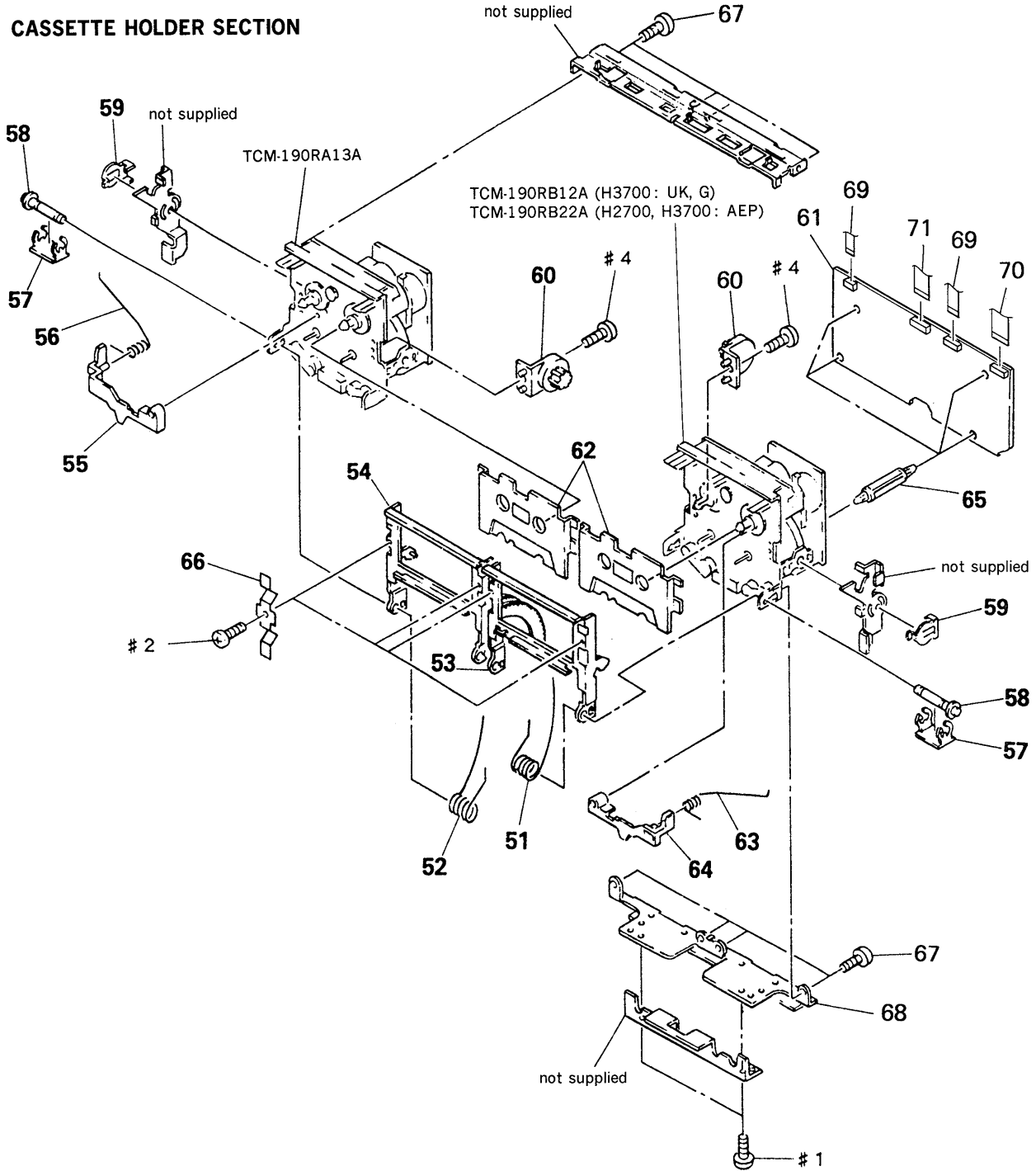

Ref. No.	Part No.	Description	Remark
51	3-354-960-01	SPRING (LOADING R), TORSION	
52	3-354-959-01	SPRING (LOADING L), TORSION	
53	X-3362-856-1	HOLDER (R) ASSY, CASSETTE	
54	X-3362-857-1	HOLDER (L) ASSY, CASSETTE	
55	3-354-955-01	LEVER (EJ SAFTY LEVER L)	
56	3-354-961-01	SPRING (EJ SAFTY SPRING L)	
57	3-367-720-01	RING (W), RETAINING	
58	3-367-721-01	SHAFT (FULCRUM SHAFT)	
59	3-354-957-01	JOINT (LOCK LEVER)	
60	3-354-963-01	DAMPER	

Ref. No.	Part No.	Description	Remark
62	3-367-711-01	RETAINER, CASSETTE	
63	3-354-962-01	SPRING (EJ SAFTY SPRING R)	
64	3-354-956-01	LEVER (EJ SAFTY LEVER R)	
* 65	3-682-419-21	HOLDER, P. C. B	
66	3-340-137-01	SPRING, CASSETTE RETAINER	
67	4-928-635-01	SCREW, +BV (2.6X8) TAPPING	
* 68	3-367-724-01	JOINT (LOWER)	
69	1-590-902-11	WIRE, FLAT TYPE (9 CORE)	
70	1-590-903-11	WIRE, FLAT TYPE (15 CORE)	
71	1-590-904-11	WIRE, FLAT TYPE (12 CORE)	

* 61 A-2006-728-A MAIN BOARD, COMPLETE (H2700, H3700:AEP)
* 61 A-2006-729-A MAIN BOARD, COMPLETE (H3700:UK, G)

6-3. MECHANISM DECK SECTION 1
(DECK A : TCM-190RA13A)
(DECK B : TCM-190RB22A)
(H2700, H3700 : AEP)
(DECK B : TCM-190RB12A)
(H3700 : UK, G)

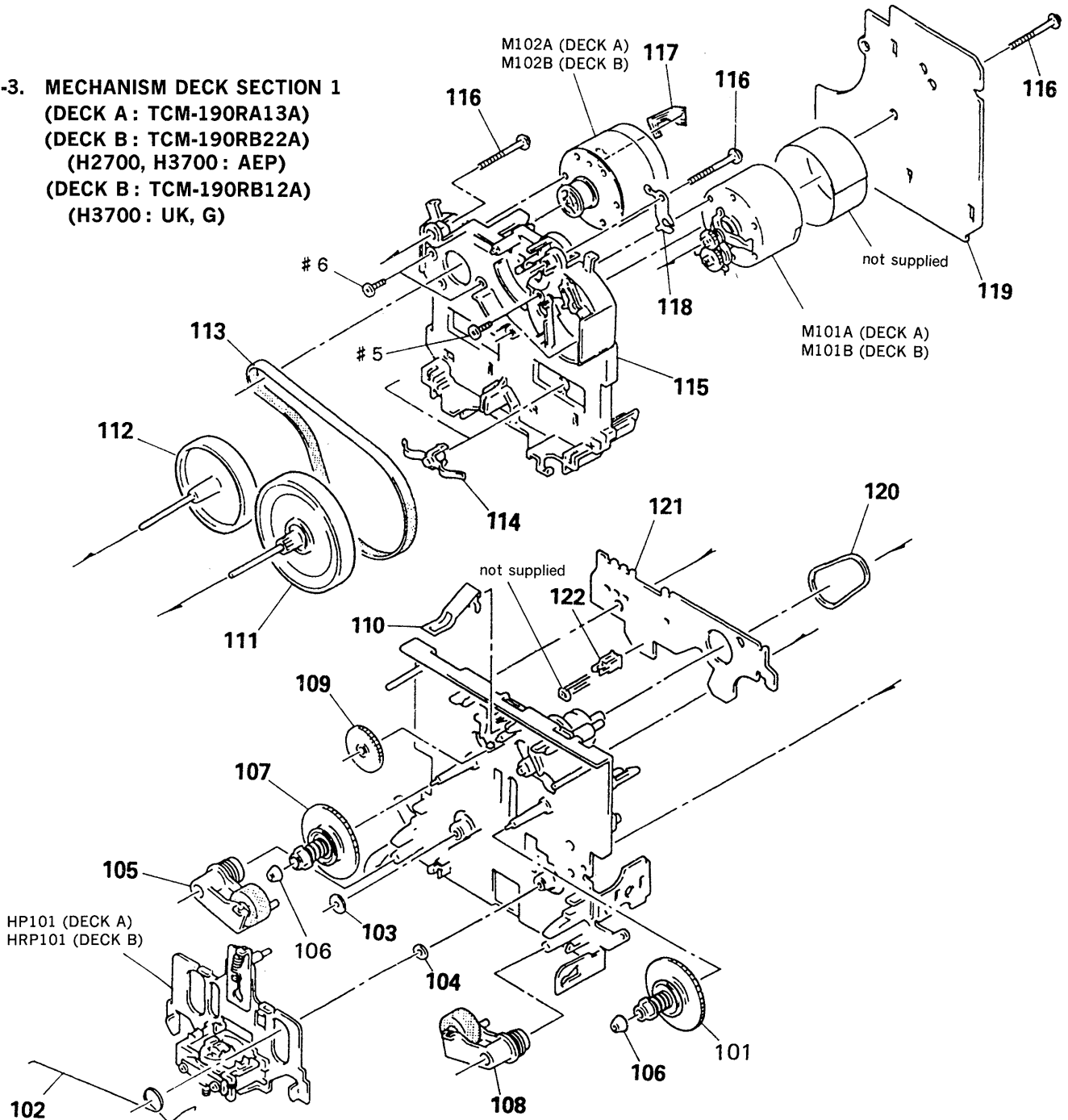

Ref. No.	Part No.	Description	Remark	Ref. No.	Part No.	Description	Remark
101	X-3359-404-1	TABLE ASSY, REEL		117	1-638-983-11	PC BOARD, MOTOR FLEXIBLE	
102	3-359-455-01	SPRING, TORSION		118	3-359-450-01	PLATE, GROUND	
103	3-356-714-01	WASHER		* 119	A-2006-399-A	MD-A BOARD, COMPLETE	
104	3-356-713-01	WASHER		* 119	A-2006-400-A	MD-B BOARD, COMPLETE (H2700, H3700:AEP)	
105	X-3359-409-1	LEVER (PINCH LEVER REV) ASSY		* 119	A-2006-401-A	MD-B HX PRO BOARD, COMPLETE (H3700:UK, G)	
106	3-362-308-01	CAP (REEL)		120	3-359-466-01	BELT (FR), SQUARE	
107	X-3362-078-1	TABLE ASSY (B), REEL		* 121	1-634-841-14	SW-A BOARD (DECK A)	
108	X-3359-408-1	LEVER (PINCH LEVER FWD) ASSY		* 121	1-634-841-14	SW-B BOARD (DECK B)	
109	3-359-424-01	GEAR (REV GEAR)		122	3-343-419-01	HOLDER (S SENSOR A)	
110	3-359-430-01	SPRING (CASSETTE RETAINER), LEAF		M101A	X-3363-501-1	MOTOR ASSY, REEL (DECK A)	
111	X-3364-554-1	FLYWHEEL (FWD) ASSY		M101B	X-3363-501-1	MOTOR ASSY, REEL (DECK B)	
112	X-3359-410-1	FLYWHEEL (REV) ASSY		M102A	X-3359-417-1	MOTOR ASSY, CAPSTAN (DECK A)	
113	3-359-417-01	BELT (FLAT), CAPSTAN		M102B	X-3359-417-1	MOTOR ASSY, CAPSTAN (DECK B)	
114	3-575-321-00	RETAINER, THRUST, CAPSTAN		HP101	A-2003-868-A	BASE ASSY, HEAD (DECK A)	
* 115	3-359-436-01	BASE (THRUST RETAINER), FITTING		HRP101	A-2003-838-A	BASE ASSY, HEAD (DECK B)	
116	3-359-414-01	SCREW (+PTPWH 2X23)					

6-4. MECHANISM DECK SECTION 2
(DECK A : TCM-190RA13A)
(DECK B : TCM-190RB22A) (H2700, H3700 : AEP)
(DECK B : TCM-190RB12A) (H3700 : UK, G)

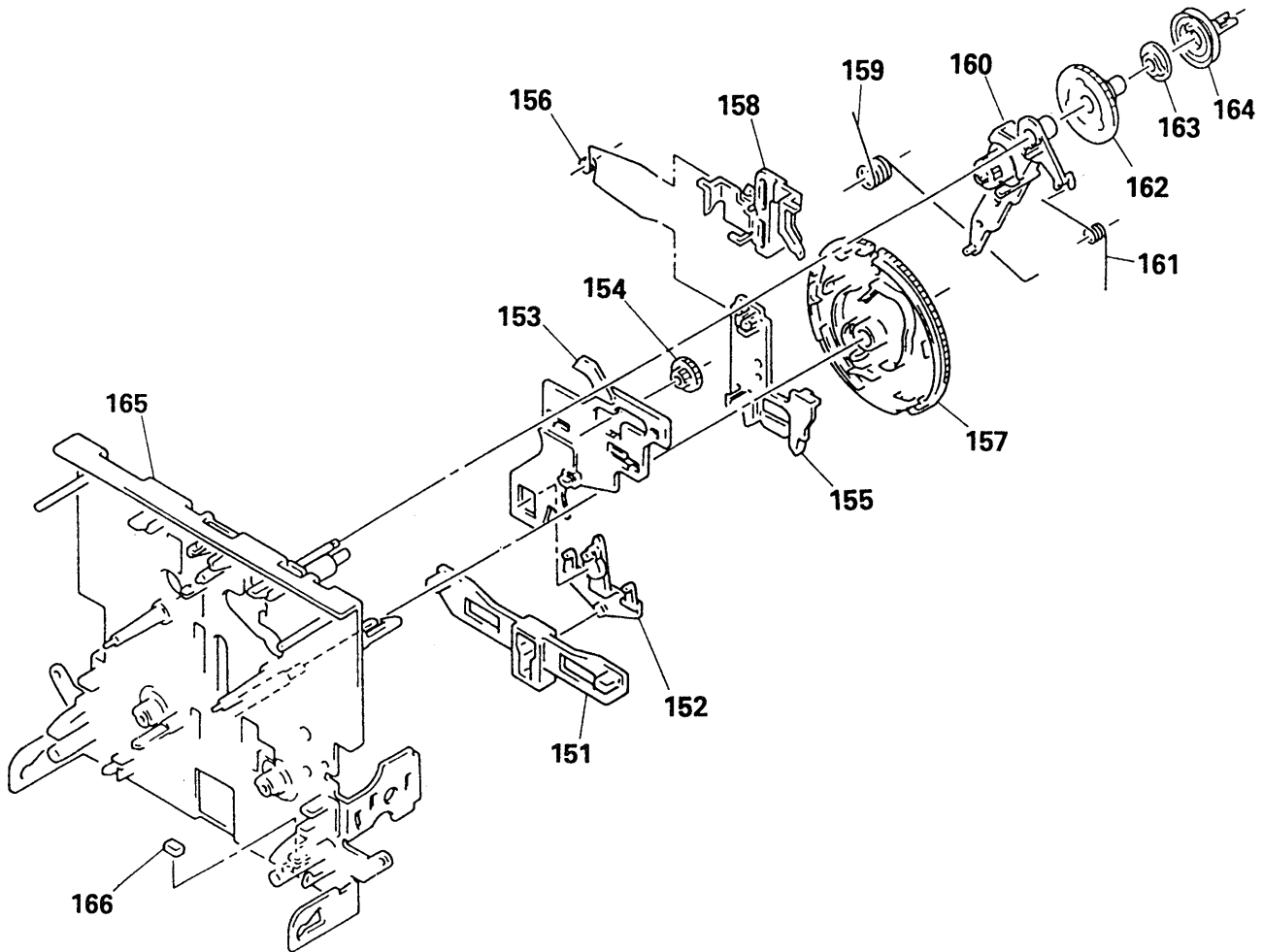

Ref. No.	Part No.	Description	Remark	Ref. No.	Part No.	Description	Remark
* 151	3-359-425-01	SLIDER (REVERSE SLIDER)		159	3-359-456-01	SPRING (TRIGGER SPRING), TORSION	
152	3-359-426-01	LEVER (REVERSE LEVER)		160	X-3359-405-1	LEVER (FR ARM) ASSY	
* 153	3-359-415-01	SLIDER (TRIGGER SLIDER)		161	3-359-453-01	SPRING (FR ARM), TORSION	
154	3-359-448-01	GEAR (TRIGGER)		162	3-359-419-01	GEAR (FR GEAR)	
* 155	3-359-427-01	SLIDER (LEVERSE SLIDER)		163	3-359-421-01	CLUTCH (REEL DISK)	
156	3-359-454-01	SPRING, TORSION		164	3-359-418-01	PULLEY (FR PULLEY)	
157	3-359-420-01	GEAR (CAM GEAR)		165	X-3363-790-1	CHASSIS ASSY, MECHANICAL	
158	3-359-429-01	SLIDER (BRAKE PLATE)		166	3-359-469-01	SPACER	

SECTION 7 ELECTRICAL PARTS LIST

MAIN

PANEL

PIN JACK

POWER

NOTE:

- Due to standardization, replacements in the parts list may be different from the parts specified in the diagrams or the components used on the set.
- -XX and -X mean standardized parts, so they may have some difference from the original one.
- RESISTORS
All resistors are in ohms.
METAL: Metal-film resistor.
METAL OXIDE: Metal oxide-film resistor.
F: nonflammable

- Items marked "*" are not stocked since they are seldom required for routine service. Some delay should be anticipated when ordering these items.
- SEMICONDUCTORS
In each case, u: μ , for example:
uA.: μ A. uPA.: μ PA.
uPB.: μ PB. uPC.: μ PC. uPD.: μ PD.
- CAPACITORS
uF: μ F
- COILS
uH: μ H

The components identified by mark Δ or dotted line with mark Δ are critical for safety. Replace only with part number specified.

When indicating parts by reference number, please include the board.

● G: Germany model

Ref. No.	Part No.	Description	Remark	Ref. No.	Part No.	Description	Remark
*	A-2006-728-A	MAIN BOARD, COMPLETE (H2700, H3700:AEP)		C210	1-163-117-00	CERAMIC CHIP 100PF	5% 50V
*	A-2006-729-A	MAIN BOARD, COMPLETE (H3700:UK, G)		C211	1-164-005-11	CERAMIC CHIP 0.47uF	25V
		*****		C212	1-164-346-11	CERAMIC CHIP 1uF	16V
*	A-2006-693-A	PANEL BOARD, COMPLETE		C213	1-163-117-00	CERAMIC CHIP 100PF	5% 50V
		*****		C214	1-164-346-11	CERAMIC CHIP 1uF	16V
*	A-2006-732-A	PIN JACK BOARD, COMPLETE		C215	1-164-505-11	CERAMIC CHIP 2.2uF	16V
		*****		C216	1-163-117-00	CERAMIC CHIP 100PF	5% 50V
*	A-2006-735-A	POWER BOARD, COMPLETE		C351	1-126-163-11	ELECT 4.7uF	20% 50V
		*****		C352	1-124-234-00	ELECT 22uF	20% 16V
*	3-309-144-21	HEAT SINK		C353	1-164-232-11	CERAMIC CHIP 0.01uF	50V
*	3-367-839-01	HOLDER, FL TUBE		C354	1-164-232-11	CERAMIC CHIP 0.01uF	50V
	7-685-646-79	SCREW +BVTP 3X8 TYPE2 N-S		C401	1-163-003-11	CERAMIC CHIP 330PF	10% 50V
	7-682-547-04	SCREW +BVTT 3X6 (S)		C402	1-163-003-11	CERAMIC CHIP 330PF	10% 50V
		< CAPACITOR >		C403	1-163-003-11	CERAMIC CHIP 330PF	10% 50V
				C404	1-163-003-11	CERAMIC CHIP 330PF	10% 50V
C101	1-136-158-00	FILM 0.027uF	5% 50V	C405	1-163-003-11	CERAMIC CHIP 330PF	10% 50V
C102	1-164-161-11	CERAMIC CHIP 0.0022uF	10% 100V	C407	1-163-117-00	CERAMIC CHIP 100PF	5% 50V
C103	1-164-182-11	CERAMIC CHIP 0.0033uF	10% 50V	C409	1-124-465-00	ELECT 0.47uF	20% 50V
C104	1-106-351-00	MYLAR 2200PF	5% 200V	C410	1-163-133-00	CERAMIC CHIP 470PF	5% 50V
C105	1-106-351-00	MYLAR 2200PF	5% 200V	C411	1-126-163-11	ELECT 4.7uF	20% 50V
C106	1-164-346-11	CERAMIC CHIP 1uF	16V	C412	1-163-018-00	CERAMIC CHIP 0.0056uF	5% 50V
C107	1-136-174-00	FILM 0.56uF	5% 50V	C413	1-163-011-11	CERAMIC CHIP 0.0015uF	10% 50V
C108	1-136-171-00	FILM 0.33uF	5% 50V	C414	1-124-257-00	ELECT 2.2uF	20% 50V
C109	1-164-346-11	CERAMIC CHIP 1uF	16V	C416	1-163-109-00	CERAMIC CHIP 47PF	5% 50V
C110	1-163-117-00	CERAMIC CHIP 100PF	5% 50V	C417	1-163-109-00	CERAMIC CHIP 47PF	5% 50V
C111	1-164-005-11	CERAMIC CHIP 0.47uF	25V	C451	1-163-003-11	CERAMIC CHIP 330PF	10% 50V
C112	1-164-346-11	CERAMIC CHIP 1uF	16V	C452	1-163-003-11	CERAMIC CHIP 330PF	10% 50V
C113	1-163-117-00	CERAMIC CHIP 100PF	5% 50V	C453	1-163-003-11	CERAMIC CHIP 330PF	10% 50V
C114	1-164-346-11	CERAMIC CHIP 1uF	16V	C454	1-163-003-11	CERAMIC CHIP 330PF	10% 50V
C115	1-164-505-11	CERAMIC CHIP 2.2uF	16V	C455	1-163-003-11	CERAMIC CHIP 330PF	10% 50V
C116	1-163-117-00	CERAMIC CHIP 100PF	5% 50V	C457	1-163-117-00	CERAMIC CHIP 100PF	5% 50V
C201	1-136-158-00	FILM 0.027uF	5% 50V	C459	1-124-465-00	ELECT 0.47uF	20% 50V
C202	1-164-161-11	CERAMIC CHIP 0.0022uF	10% 100V	C460	1-163-133-00	CERAMIC CHIP 470PF	5% 50V
C203	1-164-182-11	CERAMIC CHIP 0.0033uF	10% 50V	C461	1-126-163-11	ELECT 4.7uF	20% 50V
C204	1-106-351-00	MYLAR 2200PF	5% 200V	C462	1-163-018-00	CERAMIC CHIP 0.0056uF	5% 50V
C205	1-106-351-00	MYLAR 2200PF	5% 200V	C463	1-163-011-11	CERAMIC CHIP 0.0015uF	10% 50V
C206	1-164-346-11	CERAMIC CHIP 1uF	16V	C464	1-124-257-00	ELECT 2.2uF	20% 50V
C207	1-136-174-00	FILM 0.56uF	5% 50V	C466	1-163-109-00	CERAMIC CHIP 47PF	5% 50V
C208	1-136-171-00	FILM 0.33uF	5% 50V	C467	1-163-109-00	CERAMIC CHIP 47PF	5% 50V
C209	1-164-346-11	CERAMIC CHIP 1uF	16V	C485	1-164-232-11	CERAMIC CHIP 0.01uF	50V

MAIN

PANEL

PIN JACK

POWER

Ref. No.	Part No.	Description		Remark
C486	1-126-157-11	ELECT	10uF	20% 16V
C487	1-164-232-11	CERAMIC CHIP	0.01uF	50V
C488	1-164-232-11	CERAMIC CHIP	0.01uF	50V
C489	1-164-232-11	CERAMIC CHIP	0.01uF	50V
C490	1-164-232-11	CERAMIC CHIP	0.01uF	50V
C491	1-164-232-11	CERAMIC CHIP	0.01uF	50V
C492	1-164-232-11	CERAMIC CHIP	0.01uF	50V
C493	1-164-232-11	CERAMIC CHIP	0.01uF	50V
C494	1-164-232-11	CERAMIC CHIP	0.01uF	50V
C495	1-164-232-11	CERAMIC CHIP	0.01uF	50V
C496	1-164-232-11	CERAMIC CHIP	0.01uF	50V
C497	1-126-301-11	ELECT	1uF	20% 50V
C501	1-126-936-11	ELECT	3300uF	20% 16V
C502	1-126-936-11	ELECT	3300uF	20% 16V
C503	1-124-360-00	ELECT	1000uF	20% 16V
C504	1-126-936-11	ELECT	3300uF	20% 16V
C505	1-124-907-11	ELECT	10uF	20% 50V
C506	1-163-038-00	CERAMIC CHIP	0.1uF	25V
C507	1-124-903-11	ELECT	1uF	20% 50V
C508	1-124-472-11	ELECT	470uF	20% 10V
C509	1-124-472-11	ELECT	470uF	20% 10V
C510	1-124-477-11	ELECT	47uF	20% 25V
C512	1-124-477-11	ELECT	47uF	20% 25V
C513	1-124-903-11	ELECT	1uF	20% 50V
C514	1-124-472-11	ELECT	470uF	20% 10V
C515	1-124-477-11	ELECT	47uF	20% 25V
C516	1-124-903-11	ELECT	1uF	20% 50V
C518	1-126-927-11	ELECT	2200uF	20% 10V
C519	1-124-473-11	ELECT	1000uF	20% 10V
C520	1-163-038-00	CERAMIC CHIP	0.1uF	25V
C521	1-163-038-00	CERAMIC CHIP	0.1uF	25V
C522	1-124-927-11	ELECT	4.7uF	20% 100V
C526	1-163-037-11	CERAMIC CHIP	0.022uF	10% 25V
C527	1-163-037-11	CERAMIC CHIP	0.022uF	10% 25V
C528	1-164-232-11	CERAMIC CHIP	0.01uF	50V
C601	1-164-346-11	CERAMIC CHIP	1uF	16V
C602	1-164-346-11	CERAMIC CHIP	1uF	16V
C603	1-164-346-11	CERAMIC CHIP	1uF	16V
C604	1-164-346-11	CERAMIC CHIP	1uF	16V
C605	1-164-346-11	CERAMIC CHIP	1uF	16V
C606	1-164-346-11	CERAMIC CHIP	1uF	16V
C607	1-164-346-11	CERAMIC CHIP	1uF	16V
C608	1-124-257-00	ELECT	2.2uF	20% 50V
C609	1-163-141-00	CERAMIC CHIP	0.001uF	5% 50V
C610	1-163-038-00	CERAMIC CHIP	0.1uF	25V
C611	1-163-117-00	CERAMIC CHIP	100PF	5% 50V
C612	1-124-257-00	ELECT	2.2uF	20% 50V
C615	1-163-038-00	CERAMIC CHIP	0.1uF	25V
C616	1-163-141-00	CERAMIC CHIP	0.001uF	5% 50V

Ref. No.	Part No.	Description		Remark
C617	1-124-472-11	ELECT	470uF	20% 10V
C618	1-163-038-00	CERAMIC CHIP	0.1uF	25V
C619	1-163-141-00	CERAMIC CHIP	0.001uF	5% 50V
C620	1-164-232-11	CERAMIC CHIP	0.01uF	50V
C621	1-164-232-11	CERAMIC CHIP	0.01uF	50V
C622	1-124-472-11	ELECT	470uF	20% 10V
C623	1-163-038-00	CERAMIC CHIP	0.1uF	25V
C624	1-124-472-11	ELECT	470uF	20% 10V
C625	1-126-059-11	ELECT	10uF	20% 50V
C626	1-126-059-11	ELECT	10uF	20% 50V
C629	1-126-157-11	ELECT	10uF	20% 16V
C632	1-136-594-11	FILM	0.018uF	5% 100V
C633	1-124-465-00	ELECT	0.47uF	20% 50V
C639	1-163-038-00	CERAMIC CHIP	0.1uF	25V
C862	1-163-038-00	CERAMIC CHIP	0.1uF	25V
C4001	1-163-119-00	CERAMIC CHIP	120PF	5% 50V
C4002	1-163-119-00	CERAMIC CHIP	120PF	5% 50V
C4003	1-124-589-11	ELECT	47uF	20% 16V
C4020	1-163-037-11	CERAMIC CHIP	0.022uF	10% 25V
C4021	1-163-037-11	CERAMIC CHIP	0.022uF	10% 25V
C4022	1-124-589-11	ELECT	47uF	20% 16V
C4030	1-163-133-00	CERAMIC CHIP	470PF	5% 50V
C4031	1-163-133-00	CERAMIC CHIP	470PF	5% 50V
C4050	1-163-037-11	CERAMIC CHIP	0.022uF	10% 25V
C5001	1-163-009-11	CERAMIC CHIP	0.001uF	10% 50V
C5002	1-163-009-11	CERAMIC CHIP	0.001uF	10% 50V
C5004	1-163-037-11	CERAMIC CHIP	0.022uF	10% 25V
C5005	1-164-232-11	CERAMIC CHIP	0.01uF	50V
C5110	1-124-903-11	ELECT	1uF	20% 50V
C6008	1-163-038-00	CERAMIC CHIP	0.1uF	25V
C6009	1-163-038-00	CERAMIC CHIP	0.1uF	25V
C6010	1-163-038-00	CERAMIC CHIP	0.1uF	25V
C6011	1-163-129-00	CERAMIC CHIP	330PF	5% 50V
C6012	1-163-129-00	CERAMIC CHIP	330PF	5% 50V
C6013	1-126-023-11	ELECT	100uF	20% 16V
C6020	1-163-141-00	CERAMIC CHIP	0.001uF	5% 50V
C6021	1-163-141-00	CERAMIC CHIP	0.001uF	5% 50V
C6022	1-124-927-11	ELECT	4.7uF	20% 100V
C6026	1-163-141-00	CERAMIC CHIP	0.001uF	5% 50V
C6027	1-163-141-00	CERAMIC CHIP	0.001uF	5% 50V
C6029	1-163-141-00	CERAMIC CHIP	0.001uF	5% 50V
C6030	1-163-141-00	CERAMIC CHIP	0.001uF	5% 50V
C6031	1-163-038-00	CERAMIC CHIP	0.1uF	25V
C6035	1-163-141-00	CERAMIC CHIP	0.001uF	5% 50V
C6050	1-126-157-11	ELECT	10uF	20% 16V
(H2700, H3700:AEP)				
< CONNECTOR >				
CN351	1-580-883-21	SOCKET, CONNECTOR (SMT) 12P		

MAIN

PANEL

PIN JACK

POWER

Ref. No.	Part No.	Description	Remark
* CN401	1-568-834-11	SOCKET, CONNECTOR 15P	
* CN402	1-573-187-11	PIN, CONNECTOR (PC BOARD) 7P	
* CN403	1-573-388-11	PIN, CONNECTOR (PC BOARD) 8P	
CN601	1-573-101-11	SOCKET, CONNECTOR 9P	
CN602	1-580-783-11	CONNECTOR, BOARD TO BOARD	
CN603	1-573-101-11	SOCKET, CONNECTOR 9P	
CN604	1-580-783-11	CONNECTOR, BOARD TO BOARD	
* CN605	1-568-858-11	SOCKET, CONNECTOR 15P	
CN606	1-568-795-11	SOCKET, CONNECTOR 12P	
CN607	1-580-783-11	CONNECTOR, BOARD TO BOARD	
* CNJ401	1-580-740-11	SOCKET, CONNECTOR 17P(SYSTEM CONTROL 2)	
* CNJ402	1-573-187-11	PIN, CONNECTOR (PC BOARD) 7P	
* CNJ403	1-573-388-11	PIN, CONNECTOR (PC BOARD) 8P	
< DIODE >			
D301	8-719-027-53	DIODE SEL4226C (DUBBING MODE)	
D302	8-719-027-53	DIODE SEL4226C (CD SYNCHRO)	
D303	8-719-027-52	DIODE SEL4226E (DECK A)	
D304	8-719-027-52	DIODE SEL4226E (DECK B)	
D401	8-719-990-36	DIODE DCA010	
D403	8-719-210-33	DIODE EC10DS2	
D404	8-719-210-33	DIODE EC10DS2	
D405	8-719-990-36	DIODE DCA010	
D501	8-719-210-39	DIODE EC10QS-04	
D502	8-719-210-39	DIODE EC10QS-04	
D503	8-719-210-39	DIODE EC10QS-04	
D504	8-719-210-39	DIODE EC10QS-04	
D505	8-719-016-74	DIODE 1SS352	
D506	8-719-021-77	DIODE UZM8. 2Z	
D507	8-719-021-77	DIODE UZM8. 2Z	
D508	8-719-210-33	DIODE EC10DS2	
D509	8-719-210-33	DIODE EC10DS2	
D510	8-719-210-33	DIODE EC10DS2	
D511	8-719-210-33	DIODE EC10DS2	
D512	8-719-016-74	DIODE 1SS352	
D513	8-719-016-74	DIODE 1SS352	
D514	8-719-016-74	DIODE 1SS352	
D601	8-719-422-91	DIODE MA8091	
D602	8-719-016-74	DIODE 1SS352	
D603	8-719-016-74	DIODE 1SS352	
D604	8-719-210-39	DIODE EC10QS-04	
D605	8-719-016-74	DIODE 1SS352	
D606	8-719-422-46	DIODE MA8056	
D607	8-719-210-33	DIODE EC10DS2	
D608	8-719-210-33	DIODE EC10DS2	
D4001	8-719-016-74	DIODE 1SS352	
D6010	8-719-016-74	DIODE 1SS352	
D6011	8-719-016-74	DIODE 1SS352	
D6012	8-719-016-74	DIODE 1SS352	

Ref. No.	Part No.	Description	Remark
< FLUORESCENT INDICATOR >			
FL351	1-519-708-11	INDICATOR TUBE, FLUORESCENT	
< IC >			
IC101	8-759-300-71	IC HD14053BFP	
IC102	8-752-037-90	IC CXA1331M	
IC103	8-752-055-60	IC CXA1578M	
IC104	8-759-636-55	IC M5218AFP	
IC105	8-759-516-47	IC CD4066BCM	
IC106	8-759-998-71	IC BA3308F	
IC351	8-759-323-35	IC HD614023-FA93	
IC401	8-759-636-55	IC M5218AFP	
IC402	8-759-636-55	IC M5218AFP	
IC403	8-759-009-05	IC MC14051BF	
IC404	8-759-009-05	IC MC14051BF	
IC405	8-759-516-47	IC CD4066BCM	
IC406	8-759-636-35	IC M50760-315FP	
IC501	8-759-041-09	IC LA5603-S	
IC601	8-759-058-40	IC M50944-128FP	
IC602	8-759-636-67	IC M50925-482FP	
IC603	8-759-207-05	IC TA7272P	
IC604	8-759-636-55	IC M5218AFP	
IC605	8-759-516-41	IC CD4052BCM	
IC6001	8-759-634-43	IC M51953BFP	
< IC LINK >			
△ICP501	1-532-843-21	LI NK, IC	
△ICP502	1-532-843-21	LI NK, IC	
< JACK >			
J401	1-565-304-11	JACK, PIN 4P (DAT OUT, PHONO IN)	
* J402	1-569-812-11	JACK, PIN 6P (VIDEO IN/OUT, DAT IN)	
< JUMPER RESISTOR >			
JW3	1-216-295-00	METAL CHIP 0 5% 1/10W	
JW8	1-216-295-00	METAL CHIP 0 5% 1/10W	
JW10	1-216-295-00	METAL CHIP 0 5% 1/10W	
JW12	1-216-295-00	METAL CHIP 0 5% 1/10W	
< COIL >			
L601	1-410-761-11	INDUCTOR 0.68mH	
L4001	1-410-381-11	INDUCTOR CHIP 10uH	
L6001	1-410-482-31	INDUCTOR 100uH	
L6002	1-410-381-11	INDUCTOR CHIP 10uH	
< TRANSISTOR >			
Q101	8-729-113-13	TRANSISTOR FA1A4M-L33	
Q102	8-729-113-40	TRANSISTOR FA1A4Z-L68	

The components identified by
 mark △ or dotted line with mark.
 △ are critical for safety.
 Replace only with part number
 specified.

MAIN **PANEL** **PIN JACK** **POWER**

Ref. No.	Part No.	Description	Remark	Ref. No.	Part No.	Description	Remark
Q201	8-729-113-13	TRANSISTOR FA1A4M-L33		R118	1-216-105-00	METAL CHIP 220K 5%	1/10W
Q202	8-729-113-40	TRANSISTOR FA1A4Z-L68		R119	1-216-065-00	METAL CHIP 4.7K 5%	1/10W
Q401	8-729-805-65	TRANSISTOR 2SA1344		R120	1-216-093-00	METAL CHIP 68K 5%	1/10W
Q402	8-729-805-65	TRANSISTOR 2SA1344		R121	1-216-295-00	METAL CHIP 0 5%	1/10W
Q406	8-729-602-36	TRANSISTOR 2SA1602-F		R201	1-216-089-00	METAL CHIP 47K 5%	1/10W
Q407	8-729-602-21	TRANSISTOR 2SC4154-F		R202	1-216-089-00	METAL CHIP 47K 5%	1/10W
Q501	8-729-209-15	TRANSISTOR 2SD2012		R203	1-216-057-00	METAL CHIP 2.2K 5%	1/10W
Q502	8-729-141-83	TRANSISTOR 2SB1094-LK		R204	1-216-057-00	METAL CHIP 2.2K 5%	1/10W
Q503	8-729-805-65	TRANSISTOR 2SA1344		R205	1-216-105-00	METAL CHIP 220K 5%	1/10W
Q504	8-729-602-21	TRANSISTOR 2SC4154-F		R206	1-216-065-00	METAL CHIP 4.7K 5%	1/10W
Q505	8-729-602-21	TRANSISTOR 2SC4154-F		R207	1-216-082-00	METAL GLAZE 24K 5%	1/10W
Q506	8-729-602-36	TRANSISTOR 2SA1602-F		R208	1-216-043-00	METAL CHIP 560 5%	1/10W
Q510	8-729-602-21	TRANSISTOR 2SC4154-F		R209	1-216-073-00	METAL CHIP 10K 5%	1/10W
Q601	8-729-805-65	TRANSISTOR 2SA1344		R210	1-216-057-00	METAL CHIP 2.2K 5%	1/10W
Q602	8-729-805-65	TRANSISTOR 2SA1344		R211	1-216-097-00	METAL CHIP 100K 5%	1/10W
Q603	8-729-113-13	TRANSISTOR FA1A4M-L33		R212	1-216-065-00	METAL CHIP 4.7K 5%	1/10W
Q604	8-729-805-65	TRANSISTOR 2SA1344		R213	1-216-089-00	METAL CHIP 47K 5%	1/10W
Q605	8-729-805-69	TRANSISTOR 2SA1341		R214	1-216-057-00	METAL CHIP 2.2K 5%	1/10W
Q606	8-729-805-45	TRANSISTOR 2SC3395		R215	1-216-105-00	METAL CHIP 220K 5%	1/10W
Q607	8-729-805-65	TRANSISTOR 2SA1344		R216	1-216-085-00	METAL CHIP 33K 5%	1/10W
Q608	8-729-805-65	TRANSISTOR 2SA1344		R217	1-216-049-00	METAL CHIP 1K 5%	1/10W
Q609	8-729-113-13	TRANSISTOR FA1A4M-L33		R218	1-216-105-00	METAL CHIP 220K 5%	1/10W
Q611	8-729-805-65	TRANSISTOR 2SA1344		R219	1-216-065-00	METAL CHIP 4.7K 5%	1/10W
Q612	8-729-113-13	TRANSISTOR FA1A4M-L33		R220	1-216-093-00	METAL CHIP 68K 5%	1/10W
Q613	8-729-113-13	TRANSISTOR FA1A4M-L33		R221	1-216-295-00	METAL CHIP 0 5%	1/10W
Q616	8-729-804-41	TRANSISTOR 2SB1122-S		R351	1-216-029-00	METAL CHIP 150 5%	1/10W
Q617	8-729-804-41	TRANSISTOR 2SB1122-S		R352	1-216-033-00	METAL CHIP 220 5%	1/10W
Q619	8-729-808-01	TRANSISTOR 2SD1622-S		R353	1-216-037-00	METAL CHIP 330 5%	1/10W
Q620	8-729-808-01	TRANSISTOR 2SD1622-S		R354	1-216-041-00	METAL CHIP 470 5%	1/10W
Q6005	8-729-113-13	TRANSISTOR FA1A4M-L33		R355	1-216-045-00	METAL CHIP 680 5%	1/10W
< RESISTOR >				R356	1-216-049-00	METAL CHIP 1K 5%	1/10W
R101	1-216-089-00	METAL CHIP 47K 5%	1/10W	R357	1-216-067-00	METAL CHIP 5.6K 5%	1/10W
R102	1-216-089-00	METAL CHIP 47K 5%	1/10W	R359	1-216-045-00	METAL CHIP 680 5%	1/10W
R103	1-216-057-00	METAL CHIP 2.2K 5%	1/10W	R362	1-216-041-00	METAL CHIP 470 5%	1/10W
R104	1-216-057-00	METAL CHIP 2.2K 5%	1/10W	R363	1-216-045-00	METAL CHIP 680 5%	1/10W
R105	1-216-105-00	METAL CHIP 220K 5%	1/10W	R364	1-216-049-00	METAL CHIP 1K 5%	1/10W
R106	1-216-065-00	METAL CHIP 4.7K 5%	1/10W	R365	1-216-055-00	METAL CHIP 1.8K 5%	1/10W
R107	1-216-082-00	METAL GLAZE 24K 5%	1/10W	R366	1-216-063-00	METAL CHIP 3.9K 5%	1/10W
R108	1-216-043-00	METAL CHIP 560 5%	1/10W	R367	1-216-089-00	METAL CHIP 47K 5%	1/10W
R109	1-216-073-00	METAL CHIP 10K 5%	1/10W	R368	1-216-089-00	METAL CHIP 47K 5%	1/10W
R110	1-216-057-00	METAL CHIP 2.2K 5%	1/10W	R369	1-216-089-00	METAL CHIP 47K 5%	1/10W
R111	1-216-097-00	METAL CHIP 100K 5%	1/10W	R372	1-216-041-00	METAL CHIP 470 5%	1/10W
R112	1-216-065-00	METAL CHIP 4.7K 5%	1/10W	R374	1-216-037-00	METAL CHIP 330 5%	1/10W
R113	1-216-089-00	METAL CHIP 47K 5%	1/10W	R375	1-216-081-00	METAL CHIP 22K 5%	1/10W
R114	1-216-057-00	METAL CHIP 2.2K 5%	1/10W	R376	1-216-121-00	METAL CHIP 1M 5%	1/10W
R115	1-216-105-00	METAL CHIP 220K 5%	1/10W	R377	1-216-085-00	METAL CHIP 33K 5%	1/10W
R116	1-216-085-00	METAL CHIP 33K 5%	1/10W	R378	1-216-025-00	METAL CHIP 100 5%	1/10W
R117	1-216-049-00	METAL CHIP 1K 5%	1/10W	R379	1-216-025-00	METAL CHIP 100 5%	1/10W
				R380	1-216-025-00	METAL CHIP 100 5%	1/10W

MAIN

PANEL

PIN JACK

POWER

Ref. No.	Part No.	Description	Remark		
R381	1-216-025-00	METAL CHIP	100	5%	1/10W
R401	1-216-049-00	METAL CHIP	1K	5%	1/10W
R402	1-216-049-00	METAL CHIP	1K	5%	1/10W
R403	1-216-049-00	METAL CHIP	1K	5%	1/10W
R404	1-216-041-00	METAL CHIP	470	5%	1/10W
R405	1-216-041-00	METAL CHIP	470	5%	1/10W
R407	1-216-115-00	METAL CHIP	560K	5%	1/10W
R408	1-216-115-00	METAL CHIP	560K	5%	1/10W
R409	1-216-089-00	METAL CHIP	47K	5%	1/10W
R410	1-216-115-00	METAL CHIP	560K	5%	1/10W
R411	1-216-115-00	METAL CHIP	560K	5%	1/10W
R413	1-216-295-00	METAL CHIP	0	5%	1/10W
R414	1-216-061-00	METAL CHIP	3.3K	5%	1/10W
R415	1-216-049-00	METAL CHIP	1K	5%	1/10W
R417	1-216-089-00	METAL CHIP	47K	5%	1/10W
R418	1-216-049-00	METAL CHIP	1K	5%	1/10W
R419	1-216-115-00	METAL CHIP	560K	5%	1/10W
R420	1-216-089-00	METAL CHIP	47K	5%	1/10W
R421	1-216-001-00	METAL CHIP	10	5%	1/10W
R422	1-216-075-00	METAL CHIP	12K	5%	1/10W
R423	1-216-041-00	METAL CHIP	470	5%	1/10W
R425	1-216-025-00	METAL CHIP	100	5%	1/10W
R426	1-216-089-00	METAL CHIP	47K	5%	1/10W
R427	1-216-089-00	METAL CHIP	47K	5%	1/10W
R428	1-216-089-00	METAL CHIP	47K	5%	1/10W
R429	1-216-089-00	METAL CHIP	47K	5%	1/10W
R430	1-216-089-00	METAL CHIP	47K	5%	1/10W
R434	1-216-073-00	METAL CHIP	10K	5%	1/10W
R435	1-216-073-00	METAL CHIP	10K	5%	1/10W
R436	1-216-089-00	METAL CHIP	47K	5%	1/10W
R437	1-216-121-00	METAL CHIP	1M	5%	1/10W
R439	1-216-295-00	METAL CHIP	0	5%	1/10W
R440	1-216-089-00	METAL CHIP	47K	5%	1/10W
R441	1-216-295-00	METAL CHIP	0	5%	1/10W
R442	1-216-089-00	METAL CHIP	47K	5%	1/10W
R450	1-216-065-00	METAL CHIP	4.7K	5%	1/10W
R451	1-216-049-00	METAL CHIP	1K	5%	1/10W
R452	1-216-049-00	METAL CHIP	1K	5%	1/10W
R453	1-216-049-00	METAL CHIP	1K	5%	1/10W
R454	1-216-041-00	METAL CHIP	470	5%	1/10W
R455	1-216-041-00	METAL CHIP	470	5%	1/10W
R457	1-216-115-00	METAL CHIP	560K	5%	1/10W
R458	1-216-115-00	METAL CHIP	560K	5%	1/10W
R459	1-216-089-00	METAL CHIP	47K	5%	1/10W
R460	1-216-115-00	METAL CHIP	560K	5%	1/10W
R461	1-216-115-00	METAL CHIP	560K	5%	1/10W
R463	1-216-295-00	METAL CHIP	0	5%	1/10W
R464	1-216-061-00	METAL CHIP	3.3K	5%	1/10W
R465	1-216-049-00	METAL CHIP	1K	5%	1/10W

Ref. No.	Part No.	Description	Remark		
R467	1-216-089-00	METAL CHIP	47K	5%	1/10W
R468	1-216-049-00	METAL CHIP	1K	5%	1/10W
R469	1-216-115-00	METAL CHIP	560K	5%	1/10W
R470	1-216-089-00	METAL CHIP	47K	5%	1/10W
R471	1-216-001-00	METAL CHIP	10	5%	1/10W
R472	1-216-075-00	METAL CHIP	12K	5%	1/10W
R473	1-216-041-00	METAL CHIP	470	5%	1/10W
R475	1-216-025-00	METAL CHIP	100	5%	1/10W
R476	1-216-089-00	METAL CHIP	47K	5%	1/10W
R477	1-216-089-00	METAL CHIP	47K	5%	1/10W
R478	1-216-089-00	METAL CHIP	47K	5%	1/10W
R479	1-216-089-00	METAL CHIP	47K	5%	1/10W
R493	1-216-073-00	METAL CHIP	10K	5%	1/10W
R494	1-216-073-00	METAL CHIP	10K	5%	1/10W
R495	1-216-081-00	METAL CHIP	22K	5%	1/10W
R496	1-216-081-00	METAL CHIP	22K	5%	1/10W
R500	1-216-065-00	METAL CHIP	4.7K	5%	1/10W
R501	1-216-033-00	METAL CHIP	220	5%	1/10W
R502	1-216-041-00	METAL CHIP	470	5%	1/10W
R503	1-216-041-00	METAL CHIP	470	5%	1/10W
R504	1-216-089-00	METAL CHIP	47K	5%	1/10W
R505	1-216-089-00	METAL CHIP	47K	5%	1/10W
R506	1-216-073-00	METAL CHIP	10K	5%	1/10W
R507	1-216-073-00	METAL CHIP	10K	5%	1/10W
R508	1-216-049-00	METAL CHIP	1K	5%	1/10W
R509	1-216-057-00	METAL CHIP	2.2K	5%	1/10W
R601	1-216-081-00	METAL CHIP	22K	5%	1/10W
R602	1-216-081-00	METAL CHIP	22K	5%	1/10W
R603	1-216-057-00	METAL CHIP	2.2K	5%	1/10W
R605	1-216-081-00	METAL CHIP	22K	5%	1/10W
R606	1-216-081-00	METAL CHIP	22K	5%	1/10W
R607	1-216-081-00	METAL CHIP	22K	5%	1/10W
R608	1-216-049-00	METAL CHIP	1K	5%	1/10W
R609	1-216-083-00	METAL CHIP	27K	5%	1/10W
R610	1-216-082-00	METAL GLAZE	24K	5%	1/10W
R611	1-216-081-00	METAL CHIP	22K	5%	1/10W
R612	1-216-081-00	METAL CHIP	22K	5%	1/10W
R615	1-216-057-00	METAL CHIP	2.2K	5%	1/10W
R616	1-216-097-00	METAL CHIP	100K	5%	1/10W
R617	1-216-097-00	METAL CHIP	100K	5%	1/10W
R618	1-216-097-00	METAL CHIP	100K	5%	1/10W
R619	1-216-057-00	METAL CHIP	2.2K	5%	1/10W
R620	1-216-097-00	METAL CHIP	100K	5%	1/10W
R621	1-216-065-00	METAL CHIP	4.7K	5%	1/10W
R623	1-216-113-00	METAL CHIP	470K	5%	1/10W
R624	1-216-043-00	METAL CHIP (H2700, H3700:AEP)	560	5%	1/10W
R624	1-216-295-00	METAL CHIP (H3700:UK, G)	0	5%	1/10W

MAIN

PANEL

PIN JACK

POWER

Ref. No.	Part No.	Description			Remark
R625	1-216-061-00	METAL CHIP (H2700, H3700:AEP)	3. 3K	5%	1/10W
R625	1-216-295-00	METAL CHIP (H3700:UK, G)	0	5%	1/10W
R626	1-216-069-00	METAL CHIP (H2700, H3700:AEP)	6. 8K	5%	1/10W
R626	1-216-295-00	METAL CHIP (H3700:UK, G)	0	5%	1/10W
R628	1-216-073-00	METAL CHIP	10K	5%	1/10W
R629	1-216-057-00	METAL CHIP	2. 2K	5%	1/10W
R630	1-216-081-00	METAL CHIP	22K	5%	1/10W
R631	1-216-081-00	METAL CHIP	22K	5%	1/10W
R634	1-216-081-00	METAL CHIP	22K	5%	1/10W
R635	1-216-081-00	METAL CHIP	22K	5%	1/10W
R636	1-216-081-00	METAL CHIP	22K	5%	1/10W
R637	1-216-081-00	METAL CHIP	22K	5%	1/10W
R638	1-216-081-00	METAL CHIP	22K	5%	1/10W
R639	1-216-057-00	METAL CHIP	2. 2K	5%	1/10W
R640	1-216-057-00	METAL CHIP	2. 2K	5%	1/10W
R641	1-216-065-00	METAL CHIP	4. 7K	5%	1/10W
R642	1-216-089-00	METAL CHIP	47K	5%	1/10W
R643	1-216-089-00	METAL CHIP	47K	5%	1/10W
R644	1-216-025-00	METAL CHIP	100	5%	1/10W
R645	1-216-089-00	METAL CHIP	47K	5%	1/10W
R646	1-216-081-00	METAL CHIP	22K	5%	1/10W
R647	1-216-025-00	METAL CHIP	100	5%	1/10W
R648	1-216-025-00	METAL CHIP	100	5%	1/10W
R649	1-216-025-00	METAL CHIP	100	5%	1/10W
R650	1-216-121-00	METAL CHIP	1M	5%	1/10W
R651	1-216-081-00	METAL CHIP	22K	5%	1/10W
R652	1-216-081-00	METAL CHIP	22K	5%	1/10W
R653	1-216-073-00	METAL CHIP	10K	5%	1/10W
R654	1-216-073-00	METAL CHIP	10K	5%	1/10W
R655	1-216-121-00	METAL CHIP	1M	5%	1/10W
R656	1-216-073-00	METAL CHIP	10K	5%	1/10W
R661	1-216-083-00	METAL CHIP	27K	5%	1/10W
R662	1-216-083-00	METAL CHIP	27K	5%	1/10W
R663	1-216-073-00	METAL CHIP	10K	5%	1/10W
R664	1-216-045-00	METAL CHIP	680	5%	1/10W
R665	1-216-073-00	METAL CHIP	10K	5%	1/10W
R666	1-216-045-00	METAL CHIP	680	5%	1/10W
R667	1-216-025-00	METAL CHIP	100	5%	1/10W
R668	1-216-090-00	METAL CHIP	51K	5%	1/10W
R669	1-216-089-00	METAL CHIP	47K	5%	1/10W
R670	1-216-084-00	METAL CHIP	30K	5%	1/10W
R671	1-216-090-00	METAL CHIP	51K	5%	1/10W
R672	1-216-065-00	METAL CHIP	4. 7K	5%	1/10W
R673	1-216-080-00	METAL CHIP	20K	5%	1/10W
R674	1-216-083-00	METAL CHIP	27K	5%	1/10W

Ref. No.	Part No.	Description			Remark
R675	1-216-080-00	METAL CHIP	20K	5%	1/10W
R676	1-216-065-00	METAL CHIP	4. 7K	5%	1/10W
R677	1-216-089-00	METAL CHIP	47K	5%	1/10W
R678	1-216-084-00	METAL CHIP	30K	5%	1/10W
R679	1-216-083-00	METAL CHIP	27K	5%	1/10W
R680	1-216-090-00	METAL CHIP	51K	5%	1/10W
R681	1-216-090-00	METAL CHIP	51K	5%	1/10W
R682	1-216-025-00	METAL CHIP	100	5%	1/10W
R686	1-216-077-00	METAL CHIP	15K	5%	1/10W
R687	1-216-077-00	METAL CHIP	15K	5%	1/10W
R690	1-216-025-00	METAL CHIP	100	5%	1/10W
R691	1-216-057-00	METAL CHIP	2. 2K	5%	1/10W
R692	1-216-081-00	METAL CHIP	22K	5%	1/10W
R693	1-216-025-00	METAL CHIP	100	5%	1/10W
R695	1-216-068-00	METAL CHIP (H3700:UK, G)	6. 2K	5%	1/10W
R696	1-216-081-00	METAL CHIP	22K	5%	1/10W
R697	1-216-077-00	METAL CHIP (H3700:UK, G)	15K	5%	1/10W
R698	1-216-083-00	METAL CHIP (H3700:UK, G)	27K	5%	1/10W
R699	1-216-081-00	METAL CHIP	22K	5%	1/10W
R700	1-216-073-00	METAL CHIP	10K	5%	1/10W
R5001	1-216-025-00	METAL CHIP	100	5%	1/10W
R5002	1-216-025-00	METAL CHIP	100	5%	1/10W
R6001	1-216-073-00	METAL CHIP	10K	5%	1/10W
R6004	1-216-089-00	METAL CHIP	47K	5%	1/10W
R6005	1-216-089-00	METAL CHIP	47K	5%	1/10W
R6010	1-216-049-00	METAL CHIP	1K	5%	1/10W
R6011	1-216-298-00	METAL CHIP	2. 2	5%	1/10W
R6012	1-216-298-00	METAL CHIP	2. 2	5%	1/10W
R6013	1-216-298-00	METAL CHIP	2. 2	5%	1/10W
R6014	1-216-298-00	METAL CHIP	2. 2	5%	1/10W
R6015	1-216-298-00	METAL CHIP	2. 2	5%	1/10W
R6016	1-216-298-00	METAL CHIP	2. 2	5%	1/10W
R6017	1-216-298-00	METAL CHIP	2. 2	5%	1/10W
R6018	1-216-298-00	METAL CHIP	2. 2	5%	1/10W
R6050	1-216-025-00	METAL CHIP	100	5%	1/10W
△R6051	1-212-974-00	FUSIBLE	47	5%	1/2W F
R6060	1-216-073-00	METAL CHIP	10K	5%	1/10W
		< VARIABLE RESISTOR >			
RV101	1-241-136-11	RES, ADJ, CARBON 10K			
RV201	1-241-136-11	RES, ADJ, CARBON 10K			
		< SWITCH >			
S901	1-554-303-21	SWITCH, TACTILE (CD SYNCHRO)			
S902	1-554-303-21	SWITCH, TACTILE (▶▶)			
S903	1-554-303-21	SWITCH, TACTILE (◀◀)			

The components identified by mark △ or dotted line with mark. △ are critical for safety. Replace only with part number specified.

MAIN

PANEL

PIN JACK

POWER

MD-A

MD-B

MD-B HX PRO

Ref.No.	Part No.	Description	Remark
S904	1-554-303-21	SWITCH, TACTILE (●REC)	
S905	1-554-303-21	SWITCH, TACTILE (DECK B)	
S906	1-554-303-21	SWITCH, TACTILE (DECK A)	
S907	1-554-303-21	SWITCH, TACTILE (COUNTER RESET)	
S908	1-554-303-21	SWITCH, TACTILE (DOLBY NR)	
S909	1-554-303-21	SWITCH, TACTILE (DUBBING MODE)	
S910	1-554-303-21	SWITCH, TACTILE (■)	
S911	1-554-303-21	SWITCH, TACTILE (<)	
S912	1-554-303-21	SWITCH, TACTILE (>)	
S913	1-554-303-21	SWITCH, TACTILE (■PAUSE)	
S914	1-554-303-21	SWITCH, TACTILE (○MUTE)	
S915	1-554-303-21	SWITCH, TACTILE (DIRECTION MODE)	
< TRANSFORMER >			
T601	1-450-458-11	TRANSFORMER, DC-DC CONVERTER	
< TEST PIN >			
* TP601	1-564-718-11	PIN, CONNECTOR (SMALL TYPE) 2P	
* TP6001	1-564-517-11	PLUG, CONNECTOR 2P	
< VIBRATOR >			
X401	1-577-077-11	OSCILLATOR, CERAMIC (400kHz)	
X601	1-577-358-21	VIBRATOR, CERAMIC (4MHz)	
X951	1-577-101-11	VIBRATOR, CERAMIC (4.19MHz)	

* A-2006-399-A	MD-A BOARD, COMPLETE *****		
< CAPACITOR >			
C11	1-163-131-00	CERAMIC CHIP 390PF	5% 50V
C12	1-136-157-00	FILM 0.022uF	5% 50V
C13	1-124-234-00	ELECT 22uF	20% 16V
C18	1-163-117-00	CERAMIC CHIP 100PF	5% 50V
C21	1-163-131-00	CERAMIC CHIP 390PF	5% 50V
C22	1-136-157-00	FILM 0.022uF	5% 50V
C23	1-124-234-00	ELECT 22uF	20% 16V
C28	1-163-117-00	CERAMIC CHIP 100PF	5% 50V
C31	1-124-234-00	ELECT 22uF	20% 16V
C32	1-124-234-00	ELECT 22uF	20% 16V
C71	1-164-346-11	CERAMIC CHIP 1uF	16V
< CONNECTOR >			
* CNJ31	1-580-782-11	CONNECTOR, BOARD TO BOARD	
* CNJ72	1-580-411-11	SOCKET, CONNECTOR 4P	
* CNP32	1-580-772-11	PIN, CONNECTOR (PC BOARD) 4P	
* CNP71	1-564-719-11	PIN, CONNECTOR (SMALL TYPE) 3P	

Ref.No.	Part No.	Description	Remark
< IC >			
IC31A	8-759-106-02	IC uPC4570G2	
< JUMPER RESISTOR >			
JW1	1-216-295-00	METAL CHIP	0 5% 1/10W
JW51	1-216-296-00	METAL CHIP	0 5% 1/8W
JW52	1-216-296-00	METAL CHIP	0 5% 1/8W
JW53	1-216-296-00	METAL CHIP	0 5% 1/8W
JW54	1-216-296-00	METAL CHIP	0 5% 1/8W
< TRANSISTOR >			
Q71A	8-729-602-36	TRANSISTOR 2SA1602-F	
< RESISTOR >			
R11	1-216-099-00	METAL CHIP 120K	5% 1/10W
R12	1-216-025-00	METAL CHIP 100	5% 1/10W
R13	1-216-100-00	METAL GLAZE 130K	5% 1/10W
R14	1-216-067-00	METAL CHIP 5.6K	5% 1/10W
R21	1-216-099-00	METAL CHIP 120K	5% 1/10W
R22	1-216-025-00	METAL CHIP 100	5% 1/10W
R23	1-216-100-00	METAL GLAZE 130K	5% 1/10W
R24	1-216-067-00	METAL CHIP 5.6K	5% 1/10W
R31	1-216-033-00	METAL CHIP 220	5% 1/10W
R32	1-216-033-00	METAL CHIP 220	5% 1/10W
R71	1-216-082-00	METAL GLAZE 24K	5% 1/10W
R72	1-216-081-00	METAL CHIP 22K	5% 1/10W
R73	1-216-089-00	METAL CHIP 47K	5% 1/10W
R74	1-216-089-00	METAL CHIP 47K	5% 1/10W
< VARIABLE RESISTOR >			
RV11A	1-238-012-11	RES, ADJ, CARBON 1K	
RV21A	1-238-012-11	RES, ADJ, CARBON 1K	
RV71A	1-238-016-11	RES, ADJ, CARBON 10K	
RV72A	1-238-016-11	RES, ADJ, CARBON 10K	

* A-2006-400-A	MD-B BOARD, COMPLETE (H2700, H3700:AEP) *****		
* A-2006-401-A	MD-B HX PRO BOARD, COMPLETE (H3700:UK, G) *****		
< CAPACITOR >			
C11	1-163-131-00	CERAMIC CHIP 390PF	5% 50V
C12	1-136-157-00	FILM 0.022uF	5% 50V
C13	1-124-234-00	ELECT 22uF	20% 16V
C14	1-136-273-91	FILM 75PF	5% 630V
C15	1-164-080-11	CERAMIC 390PF	10% 50V (H2700, H3700:AEP)

MD-B

MD-B HX PRO

Ref.No.	Part No.	Description	Remark
C17	1-163-103-00	CERAMIC CHIP 27PF (H2700, H3700:AEP)	5% 50V
C18	1-163-117-00	CERAMIC CHIP 100PF	5% 50V
C21	1-163-131-00	CERAMIC CHIP 390PF	5% 50V
C22	1-136-157-00	FILM 0.022uF	5% 50V
C23	1-124-234-00	ELECT 22uF	20% 16V
C24	1-136-273-91	FILM 75PF (H2700, H3700:AEP)	5% 630V
C25	1-164-080-11	CERAMIC 390PF (H2700, H3700:AEP)	10% 50V
C27	1-163-103-00	CERAMIC CHIP 27PF (H2700, H3700:AEP)	5% 50V
C28	1-163-117-00	CERAMIC CHIP 100PF	5% 50V
C31	1-124-234-00	ELECT 22uF	20% 16V
C32	1-124-234-00	ELECT 22uF	20% 16V
C33	1-124-234-00	ELECT 22uF	20% 16V
C51	1-163-019-00	CERAMIC CHIP 0.0068uF (H2700, H3700:AEP)	10% 50V
C51	1-164-161-11	CERAMIC CHIP 0.0022uF (H3700:UK, G)	10% 100V
C52	1-163-019-00	CERAMIC CHIP 0.0068uF (H2700, H3700:AEP)	10% 50V
C52	1-164-161-11	CERAMIC CHIP 0.0022uF (H3700:UK, G)	10% 100V
C53	1-163-022-00	CERAMIC CHIP 0.012uF (H2700, H3700:AEP)	10% 50V
C53	1-163-019-00	CERAMIC CHIP 0.0068uF (H3700:UK, G)	10% 50V
C54	1-136-559-11	FILM 0.0047uF (H2700, H3700:AEP)	5% 630V
C54	1-136-601-11	FILM 0.01uF (H3700:UK, G)	5% 630V
C56	1-164-505-11	CERAMIC CHIP 2.2uF	16V
C57	1-164-346-11	CERAMIC CHIP 1uF	16V
C58	1-163-024-00	CERAMIC CHIP 0.018uF (H2700, H3700:AEP)	10% 50V
C71	1-164-346-11	CERAMIC CHIP 1uF	16V
C80	1-124-234-00	ELECT 22uF (H3700:UK, G)	20% 16V
C81	1-164-232-11	CERAMIC CHIP 0.01uF (H3700:UK, G)	50V
C82	1-136-157-00	FILM 0.022uF (H3700:UK, G)	5% 50V
C83	1-164-004-11	CERAMIC CHIP 0.1uF (H3700:UK, G)	10% 25V
C84	1-136-478-11	FILM 470PF (H3700:UK, G)	5% 630V
C85	1-136-433-11	FILM 100PF (H3700:UK, G)	5% 630V
C86	1-163-143-00	CERAMIC CHIP 0.0012uF (H3700:UK, G)	5% 50V

Ref.No.	Part No.	Description	Remark
C87	1-136-273-91	FILM 75PF (H3700:UK, G)	5% 630V
C88	1-163-003-11	CERAMIC CHIP 330PF (H3700:UK, G)	10% 50V
C89	1-124-234-00	ELECT 22uF (H3700:UK, G)	20% 16V
C90	1-107-045-00	MICA 3.9PF (H3700:UK, G)	500V
C91	1-164-232-11	CERAMIC CHIP 0.01uF (H3700:UK, G)	50V
C92	1-136-157-00	FILM 0.022uF (H3700:UK, G)	5% 50V
C93	1-164-004-11	CERAMIC CHIP 0.1uF (H3700:UK, G)	10% 25V
C94	1-136-478-11	FILM 470PF (H3700:UK, G)	5% 630V
C95	1-136-433-11	FILM 100PF (H3700:UK, G)	5% 630V
C96	1-163-143-00	CERAMIC CHIP 0.0012uF (H3700:UK, G)	5% 50V
C97	1-136-273-91	FILM 75PF (H3700:UK, G)	5% 630V
C98	1-163-003-11	CERAMIC CHIP 330PF (H3700:UK, G)	10% 50V
C99	1-164-005-11	CERAMIC CHIP 0.47uF (H3700:UK, G)	25V
< CONNECTOR >			
* CNJ31	1-580-782-11	CONNECTOR, BOARD TO BOARD (H2700, H3700:AEP)	
* CNJ33	1-580-782-11	CONNECTOR, BOARD TO BOARD (H2700, H3700:AEP)	
* CNJ72	1-580-411-11	SOCKET, CONNECTOR 4P (H2700, H3700:AEP)	
* CNP31	1-580-782-11	CONNECTOR, BOARD TO BOARD (H3700:UK, G)	
* CNP32	1-580-781-11	PIN, CONNECTOR (PC BOARD) 7P	
* CNP33	1-580-782-11	CONNECTOR, BOARD TO BOARD (H3700:UK, G)	
* CNP71	1-564-719-11	PIN, CONNECTOR (SMALL TYPE) 3P	
* CNP72	1-580-411-11	SOCKET, CONNECTOR 4P (H3700:UK, G)	
< DIODE >			
D31	8-719-016-74	DIODE 1SS352	
< IC >			
IC31B	8-759-106-02	IC uPC4570G2	
IC81	8-759-106-56	IC uPC1297CA (H3700:UK, G)	
< JUMPER RESISTOR >			
JW1	1-216-296-00	METAL CHIP 0 (H2700, H3700:AEP)	5% 1/8W
JW2	1-216-295-00	METAL CHIP 0 (H2700, H3700:AEP)	5% 1/10W

MD-B

MD-B HX PRO

Ref. No.	Part No.	Description	Remark
JW3	1-216-295-00	METAL CHIP 0 (H2700, H3700:AEP)	5% 1/10W
JW4	1-216-295-00	METAL CHIP 0 (H2700, H3700:AEP)	5% 1/10W
JW5	1-216-295-00	METAL CHIP 0 (H2700, H3700:AEP)	5% 1/10W
JW6	1-216-295-00	METAL CHIP 0 (H2700, H3700:AEP)	5% 1/10W
JW7	1-216-295-00	METAL CHIP 0 (H2700, H3700:AEP)	5% 1/10W
JW52	1-216-296-00	METAL CHIP 0 (H2700, H3700:AEP)	5% 1/8W
JW53	1-216-296-00	METAL CHIP 0 (H2700, H3700:AEP)	5% 1/8W
JW54	1-216-296-00	METAL CHIP 0 (H2700, H3700:AEP)	5% 1/8W
JW55	1-216-296-00	METAL CHIP 0 (H2700, H3700:AEP)	5% 1/8W
JW56	1-216-296-00	METAL CHIP 0 (H2700, H3700:AEP)	5% 1/8W
JW57	1-216-296-00	METAL CHIP 0 (H2700, H3700:AEP)	5% 1/8W
JW58	1-216-296-00	METAL CHIP 0 (H2700, H3700:AEP)	5% 1/8W
JW59	1-216-296-00	METAL CHIP 0 (H2700, H3700:AEP)	5% 1/8W
JW60	1-216-296-00	METAL CHIP 0 (H2700, H3700:AEP)	5% 1/8W
JW61	1-216-296-00	METAL CHIP 0 (H2700, H3700:AEP)	5% 1/8W
< COIL >			
L11	1-410-780-11	INDUCTOR 27mH (H2700, H3700:AEP)	
L21	1-410-780-11	INDUCTOR 27mH (H2700, H3700:AEP)	
L81	1-410-780-11	INDUCTOR 27mH (H3700:UK, G)	
L91	1-410-780-11	INDUCTOR 27mH (H3700:UK, G)	
< TRANSISTOR >			
Q51	8-729-808-01	TRANSISTOR 2SD1622-S	
Q52	8-729-808-01	TRANSISTOR 2SD1622-S	
Q53	8-729-808-01	TRANSISTOR 2SD1622-S	
Q71B	8-729-602-36	TRANSISTOR 2SA1602-F (H2700, H3700:AEP)	
Q71B	8-729-216-22	TRANSISTOR 2SA1162-C (H3700:UK, G)	
< RESISTOR >			
R11	1-216-099-00	METAL CHIP 120K 5%	1/10W
R12	1-216-025-00	METAL CHIP 100 5%	1/10W
R13	1-216-100-00	METAL GLAZE 130K 5%	1/10W
R14	1-216-067-00	METAL CHIP 5.6K 5%	1/10W
△R15	1-249-430-11	CARBON 12K 5% (H2700, H3700:AEP)	1/4W F

Ref. No.	Part No.	Description	Remark
R21	1-216-099-00	METAL CHIP 120K 5%	1/10W
R22	1-216-025-00	METAL CHIP 100 5%	1/10W
R23	1-216-100-00	METAL GLAZE 130K 5%	1/10W
R24	1-216-067-00	METAL CHIP 5.6K 5%	1/10W
△R25	1-249-430-11	CARBON 12K 5% (H2700, H3700:AEP)	1/4W F
R31	1-216-033-00	METAL CHIP 220 5%	1/10W
R32	1-216-033-00	METAL CHIP 220 5%	1/10W
△R41	1-249-393-11	CARBON 10 5% (H2700, H3700:AEP)	1/4W F
△R42	1-249-393-11	CARBON 10 5% (H2700, H3700:AEP)	1/4W F
R51	1-216-075-00	METAL CHIP 12K 5%	1/10W
R51	1-216-097-00	METAL CHIP 100K 5% (H3700:UK, G)	1/10W
R52	1-216-075-00	METAL CHIP 12K 5% (H2700, H3700:AEP)	1/10W
R52	1-216-097-00	METAL CHIP 100K 5% (H3700:UK, G)	1/10W
R53	1-216-073-00	METAL CHIP 10K 5%	1/10W
R54	1-216-309-00	METAL CHIP 5.6 5%	1/10W
R55	1-216-309-00	METAL CHIP 5.6 5%	1/10W
R56	1-216-298-00	METAL CHIP 2.2 5% (H2700, H3700:AEP)	1/10W
R57	1-216-298-00	METAL CHIP 2.2 5% (H3700:UK, G)	1/10W
R71	1-216-082-00	METAL GLAZE 24K 5%	1/10W
R72	1-216-081-00	METAL CHIP 22K 5%	1/10W
R73	1-216-089-00	METAL CHIP 47K 5%	1/10W
R74	1-216-089-00	METAL CHIP 47K 5%	1/10W
R81	1-216-073-00	METAL CHIP 10K 5% (H3700:UK, G)	1/10W
R82	1-216-085-00	METAL CHIP 33K 5% (H3700:UK, G)	1/10W
R83	1-216-001-00	METAL CHIP 10 5% (H3700:UK, G)	1/10W
R84	1-216-101-00	METAL CHIP 150K 5% (H3700:UK, G)	1/10W
R85	1-216-075-00	METAL CHIP 12K 5% (H3700:UK, G)	1/10W
R91	1-216-073-00	METAL CHIP 10K 5% (H3700:UK, G)	1/10W
R92	1-216-085-00	METAL CHIP 33K 5% (H3700:UK, G)	1/10W
R93	1-216-001-00	METAL CHIP 10 5% (H3700:UK, G)	1/10W
R94	1-216-101-00	METAL CHIP 150K 5% (H3700:UK, G)	1/10W
R95	1-216-075-00	METAL CHIP 12K 5% (H3700:UK, G)	1/10W

The components identified by mark △ or dotted line with mark △ are critical for safety. Replace only with part number specified.

MD-B

MD-B HX PRO

SW-A

SW-B

Ref. No.	Part No.	Description	Remark
< VARIABLE RESISTOR >			
RV11B	1-238-012-11	RES, ADJ, CARBON 1K	
RV12	1-238-551-11	RES, ADJ, CARBON 220K (H2700, H3700:AEP)	
RV21B	1-238-012-11	RES, ADJ, CARBON 1K	
RV22	1-238-551-11	RES, ADJ, CARBON 220K (H2700, H3700:AEP)	
RV71B	1-238-016-11	RES, ADJ, CARBON 10K	
RV72B	1-238-016-11	RES, ADJ, CARBON 10K	
RV81	1-241-122-11	RES, ADJ, CARBON 22K (H3700:UK, G)	
RV91	1-241-122-11	RES, ADJ, CARBON 22K (H3700:UK, G)	
< RELAY >			
RY31	1-515-726-11	RELAY	
< TRANSFORMER >			
T51	1-406-419-11	COIL, BIAS OSCILLATION (H2700, H3700:AEP)	
T51	1-406-417-11	COIL, BIAS OSCILLATION (H3700:UK, G)	
T81	1-433-381-11	TRANSFORMER, BIAS OSCILLATOR (H3700:UK, G)	
T91	1-433-381-11	TRANSFORMER, BIAS OSCILLATOR (H3700:UK, G)	
< TEST PIN >			
* TP81	1-568-449-11	HOUSING, CONNECTOR(PC BOARD) 3P (H3700:UK, G)	

* 1-634-841-14	SW-A BOARD	*****	
3-343-419-01	HOLDER (S SENSER A)		
< CONNECTOR >			
* CNP81	1-568-852-11	SOCKET, CONNECTOR 9P	
< IC >			
IC81A	8-719-710-03	DIODE NJL5165K-B	
< RESISTOR >			
R84	1-249-417-11	CARBON 1K 5% 1/4W	
R85	1-249-408-11	CARBON 180 5% 1/4W	
< SWITCH >			
S81	1-571-958-11	SWITCH, PUSH (1 KEY) (STOP DET)	
S82	1-571-281-21	SWITCH, LEAF (CrO2 DET)	
S86	1-571-281-21	SWITCH, LEAF (HALF DET)	

Ref. No.	Part No.	Description	Remark
* 1-634-841-14	SW-B BOARD	*****	
3-343-419-01	HOLDER (S SENSER A)		
< CONNECTOR >			
* CNP81	1-568-852-11	SOCKET, CONNECTOR 9P	
< IC >			
IC81B	8-719-710-03	DI ODE NJL5165K-B	
< RESISTOR >			
R81	1-249-414-11	CARBON 560 5% 1/4W	
R82	1-247-818-11	CARBON 300 5% 1/4W	
R83	1-247-834-11	CARBON 1.3K 5% 1/4W	
R84	1-249-417-11	CARBON 1K 5% 1/4W	
R85	1-249-408-11	CARBON 180 5% 1/4W	
< SWITCH >			
S81	1-571-958-11	SWITCH, PUSH (1 KEY) (STOP DET)	
S82	1-571-281-21	SWITCH, LEAF (CrO2 DET)	
S83	1-571-281-21	SWITCH, LEAF (METAL DET)	
S84	1-571-281-21	SWITCH, LEAF (ERASE PROOF SIDE A)	
S85	1-571-281-21	SWITCH, LEAF (ERASE PROOF SIDE B)	
S86	1-571-281-21	SWITCH, LEAF (HALF DET)	

MISCELLANEOUS			

* 17	1-573-188-11	CONNECTOR, BRIDGE 7P	
* 18	1-573-389-11	CONNECTOR, BRIDGE 8P	
69	1-590-902-11	WIRE, FLAT TYPE (9 CORE)	
70	1-590-903-11	WIRE, FLAT TYPE (15 CORE)	
71	1-590-904-11	WIRE, FLAT TYPE (12 CORE)	
117	1-638-983-11	PC BOARD, MOTOR FLEXIBLE	
HP101	A-2003-868-A	BASE ASSY, HEAD (DECK A)	
HRP101	A-2003-838-A	BASE ASSY, HEAD (DECK B)	
M101A	X-3363-501-1	MOTOR ASSY, REEL (DECK A)	
M101B	X-3363-501-1	MOTOR ASSY, REEL (DECK B)	
M102A	X-3359-417-1	MOTOR ASSY, CAPSTAN (DECK A)	
M102B	X-3359-417-1	MOTOR ASSY, CAPSTAN (DECK B)	

Ref. No.	Part No.	Description	Remark
----------	----------	-------------	--------

HARDWARE LIST

#1	7-685-646-79	SCREW +BVTP 3X8 TYPE2 N-S	
#2	7-621-255-15	SCREW +PTT 2X3 (S)	
#3	7-685-134-19	SCREW +BTP 2. 6X8 TYPE2 N-S	
#4	7-621-770-67	SCREW +PTT 2. 6X6 (S)	
#5	7-627-556-08	SCREW +P 2. 6X2. 8	
#6	7-621-775-00	SCREW +B 2. 6X3	
#7	7-682-547-04	SCREW +BVTT 3X6 (S)	
#8	7-621-849-00	SCREW, TAPPING	

