

TA-H2700

SERVICE MANUAL

*AEP Model
UK Model
E Model
Australian Model
Tourist Model*



This set is the Amplifier section in MHC-2700 and FH-E757.

This photo is AEP, UK, G and IT model.

SPECIFICATIONS

Continuous RMS power output	40+40 watts (6 ohms at 1kHz, 5% THD) (For AEP, UK, G, IT) 35+35 watts (6 ohms at 1kHz, DIN) (For E, AUS, EA, JE)
Music power output (for AEP, UK, G, IT)	60+60 watts (6 ohms at 1kHz, 10% THD)
Peak music power output (for E, AUS, EA, JE)	480 watts (4 speakers driven)
Inputs	MIX MIC (minijack): (For E, AUS, EA, JE): sensitivity 1mV, impedance 600 ohms ADAPTOR (pin jacks) (For E, AUS, EA, JE): sensitivity 300mV, impedance 47 kilohms
Outputs	HEADPHONES (stereo minijack): accepts headphones of 8 ohms or more. ADAPTOR (pin jacks) (For E, AUS, EA, JE): output level 300mV impedance 10 kilohms

Design and specifications subject to change without notice.

- G : Germany model
- IT : Italian model
- AUS: Australian model
- EA : Saudi Arabia model
- JE : Tourist model

SAFETY-RELATED COMPONENT WARNING!!

COMPONENTS IDENTIFIED BY MARK Δ OR DOTTED LINE WITH MARK Δ ON THE SCHEMATIC DIAGRAMS AND IN THE PARTS LIST ARE CRITICAL TO SAFE OPERATION. REPLACE THESE COMPONENTS WITH SONY PARTS WHOSE PART NUMBERS APPEAR AS SHOWN IN THIS MANUAL OR IN SUPPLEMENTS PUBLISHED BY SONY.

INTEGRATED STEREO AMPLIFIER
SONY®



<u>Section</u>	<u>Title</u>	<u>Page</u>
1. GENERAL		
1-1.	Parts Identification	2
2. DISASSEMBLY		
2-1.	Front Panel Assy	3
2-2.	Jack Board, Speaker Board	3
2-3.	Audio Board, AC Board	4
2-4.	Power Amplifier Board, Power Transformer	4
3. DIAGRAMS		
3-1.	Circuit Boards Location	5
3-2.	Semiconductor Lead Layouts	6
3-3.	Printed Wiring Board—Audio Section—	7
3-4.	Schematic Diagram—Audio Section—	9
3-5.	Schematic Diagram—AC/Volume Section—	13
3-6.	Printed Wiring Boards—AC/Volume Section—	17
3-7.	Printed Wiring Boards —Power/Power Amplifier Section—	19
3-8.	Schematic Diagram —Power/Power Amplifier Section—	21
3-9.	Schematic Diagram—Panel Section—	24
3-10.	Printed Wiring Board—Panel Section—	27
3-11.	Pin Functions of IC501 (μ PD78134GF-051-3B9)	31
4. EXPLODED VIEW		
4-1.	Main Section	33
5. ELECTRICAL PARTS LIST		
		35

MODEL IDENTIFICATION

—Model Number Label—

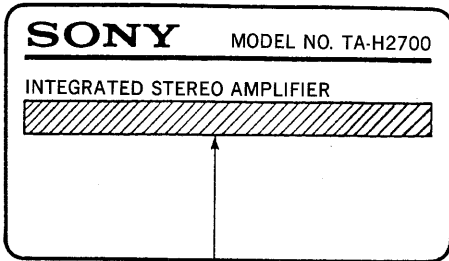

AEP, G model : AC: 220—230V~50/60Hz
 IT model : AC: 220—230V~50Hz
 UK model : AC: 240V~50Hz
 E, AUS, EA,
 JE model : AC: 120/220/240V~50/60Hz 140W

- G : Germany model
- IT : Italian model
- AUS: Australian model
- EA : Saudi Arabia model
- JE : Tourist model

**SECTION 1
GENERAL**

This section is extracted from instruction manual.

1-1. PARTS IDENTIFICATION

- 1 WAKE UP VOL SET button and indicator
- 2 SYSTEM POWER switch and STANDBY indicator
The indicator remains lit as long as the AC power cord is connected to a wall outlet.
- 3 DISPLAY button
- 4 Display window
- 5 VOLUME control
- 6 FUNCTION <-> buttons
- 7 T.P.O. button
- 8 DIRECT button
- 9 TOTAL EFFECT CONTROL -/+ buttons
- 10 MUSIC button
- 11 Function indicators
- 12 (For AEP, UK, G, IT) MUTING button,
(For E, AUS, EA, JE) KARAOKE PON button and indicator
- 13 MIC (microphone) LEVEL control (For E, AUS, EA, JE)
- 14 MIX MIC (microphone) input jack (For E, AUS, EA, JE)
- 15 HEADPHONES jack (stereo minijack)

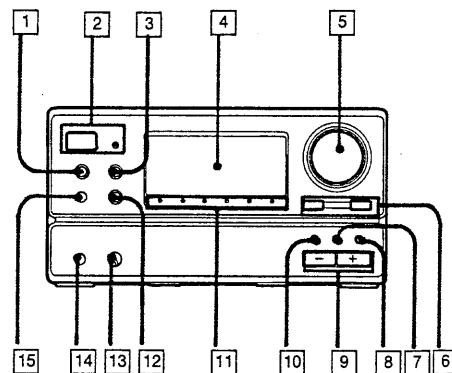

SECTION 2 DISASSEMBLY

Note: Follow the disassembly procedure in the numerical order given.

2-1. FRONT PANEL ASSY

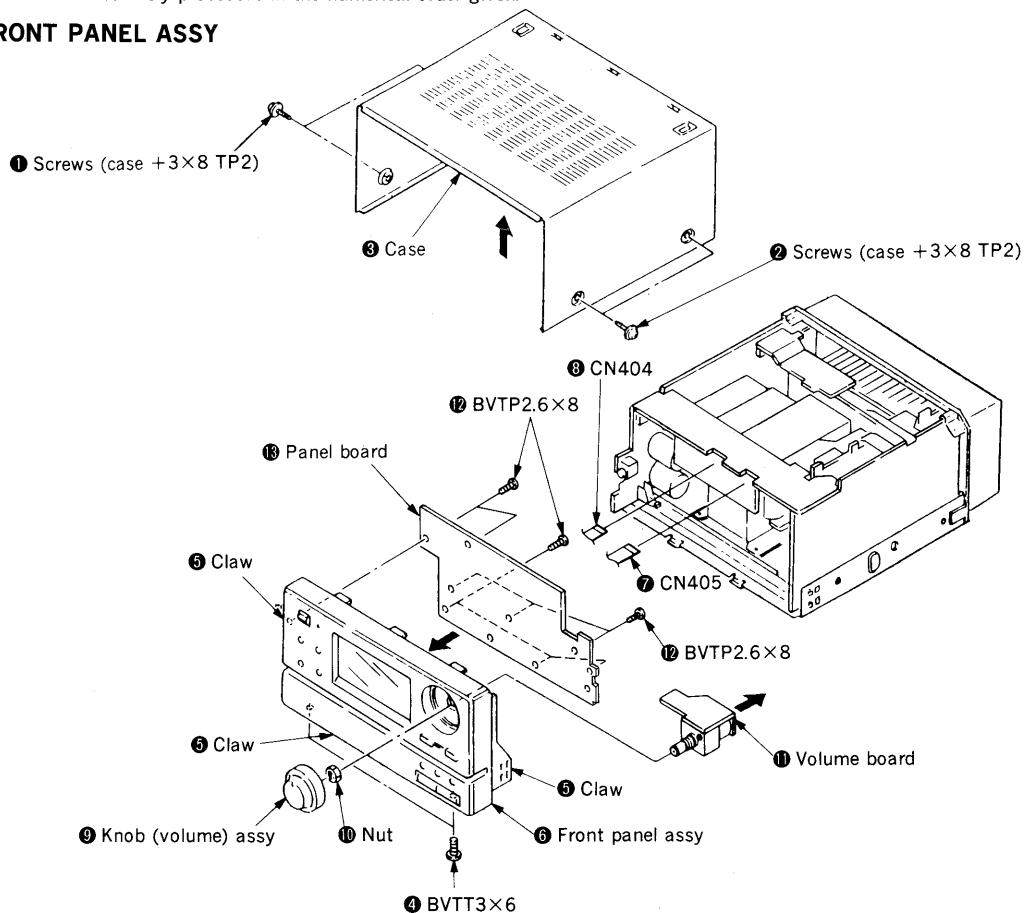

2-2. JACK BOARD, SPEAKER BOARD

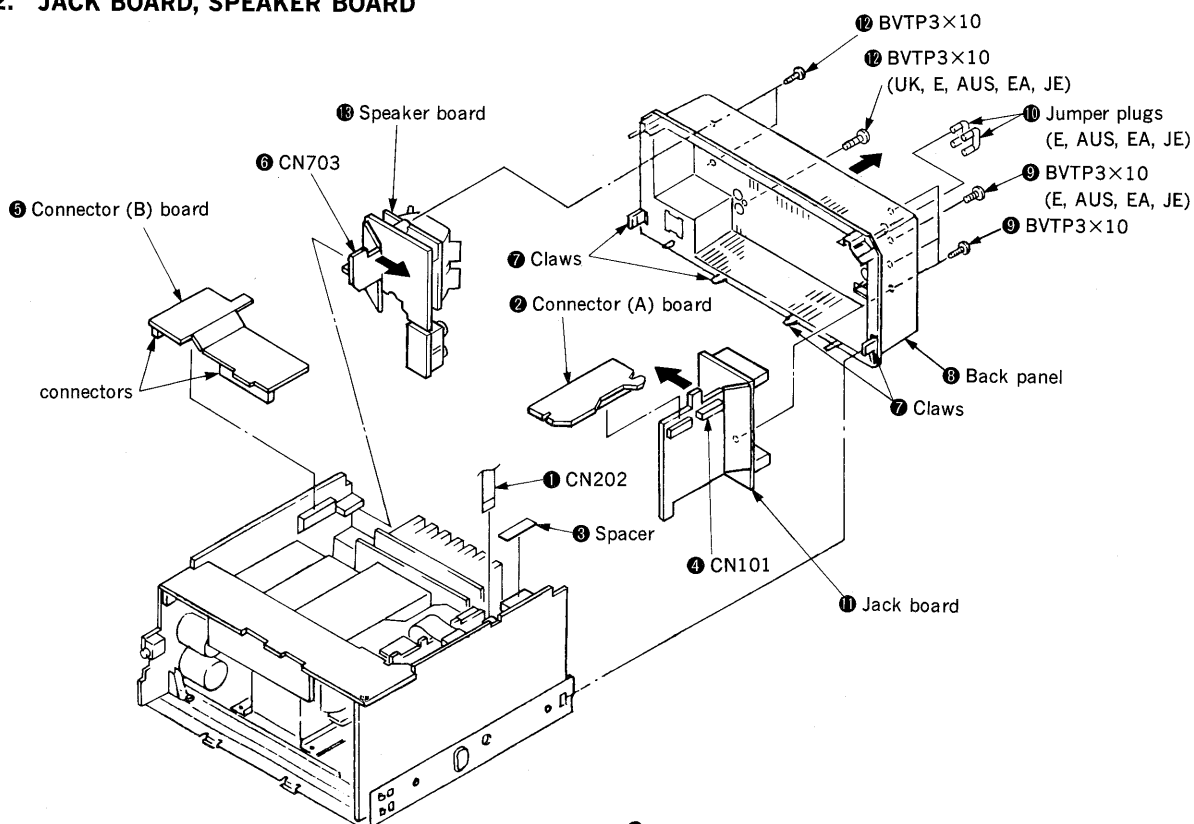

2-3. AUDIO BOARD, AC BOARD

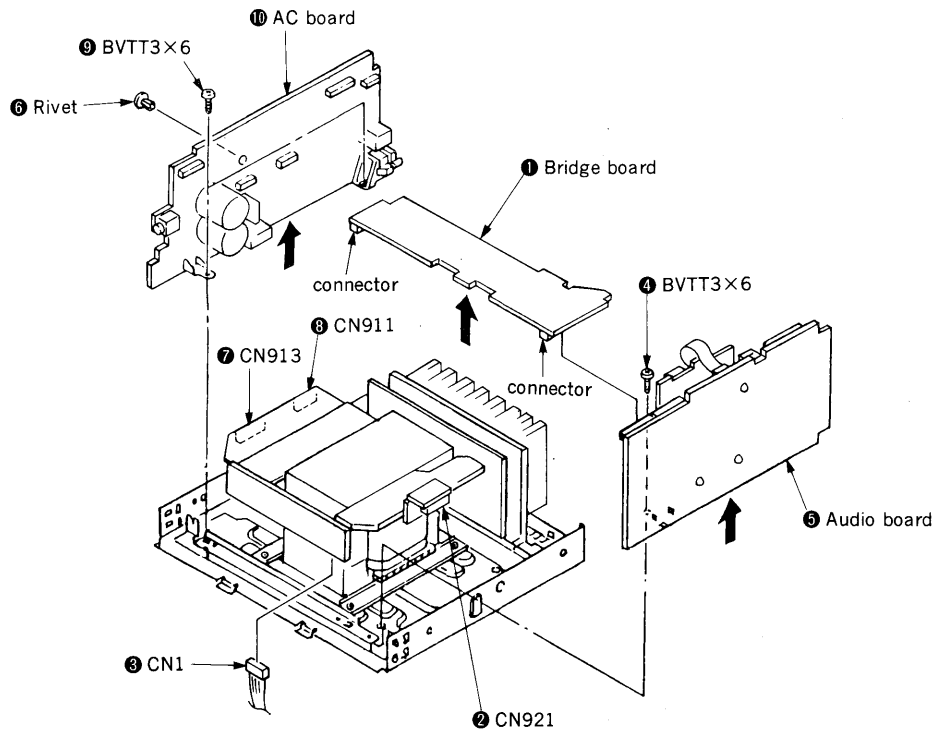

2-4. POWER AMPLIFIER BOARD, POWER TRANSFORMER

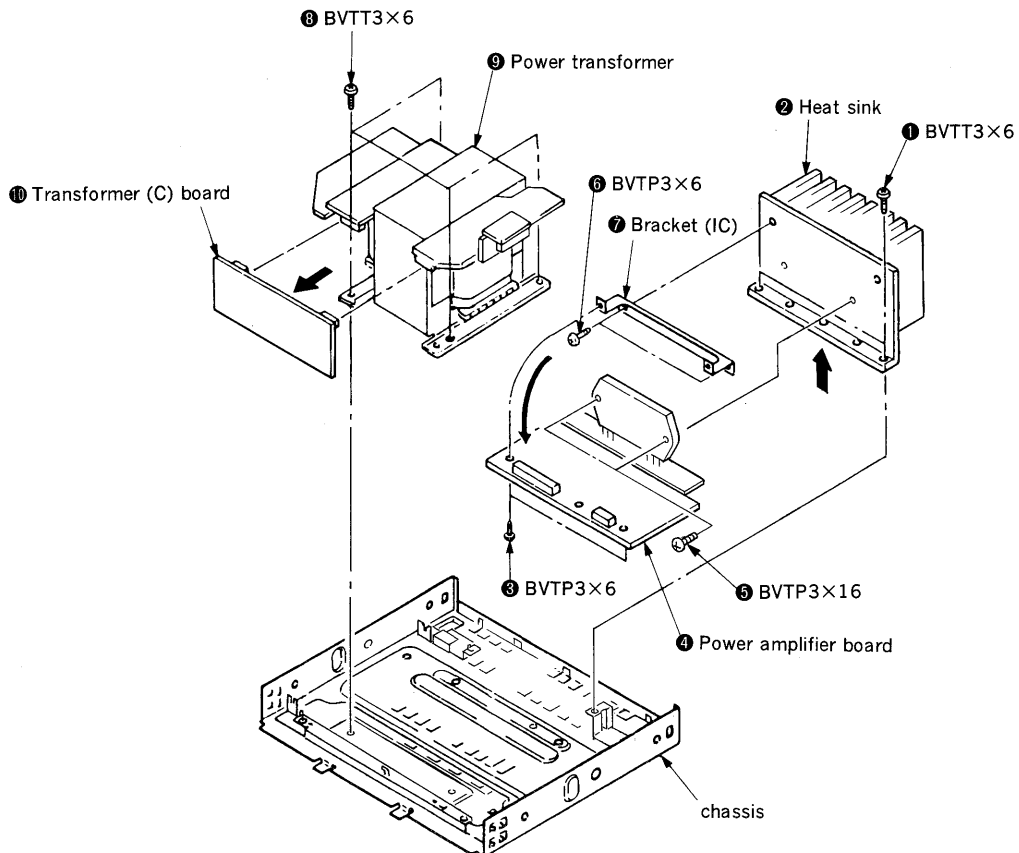

**SECTION 3
DIAGRAMS**

3-1. CIRCUIT BOARDS LOCATION

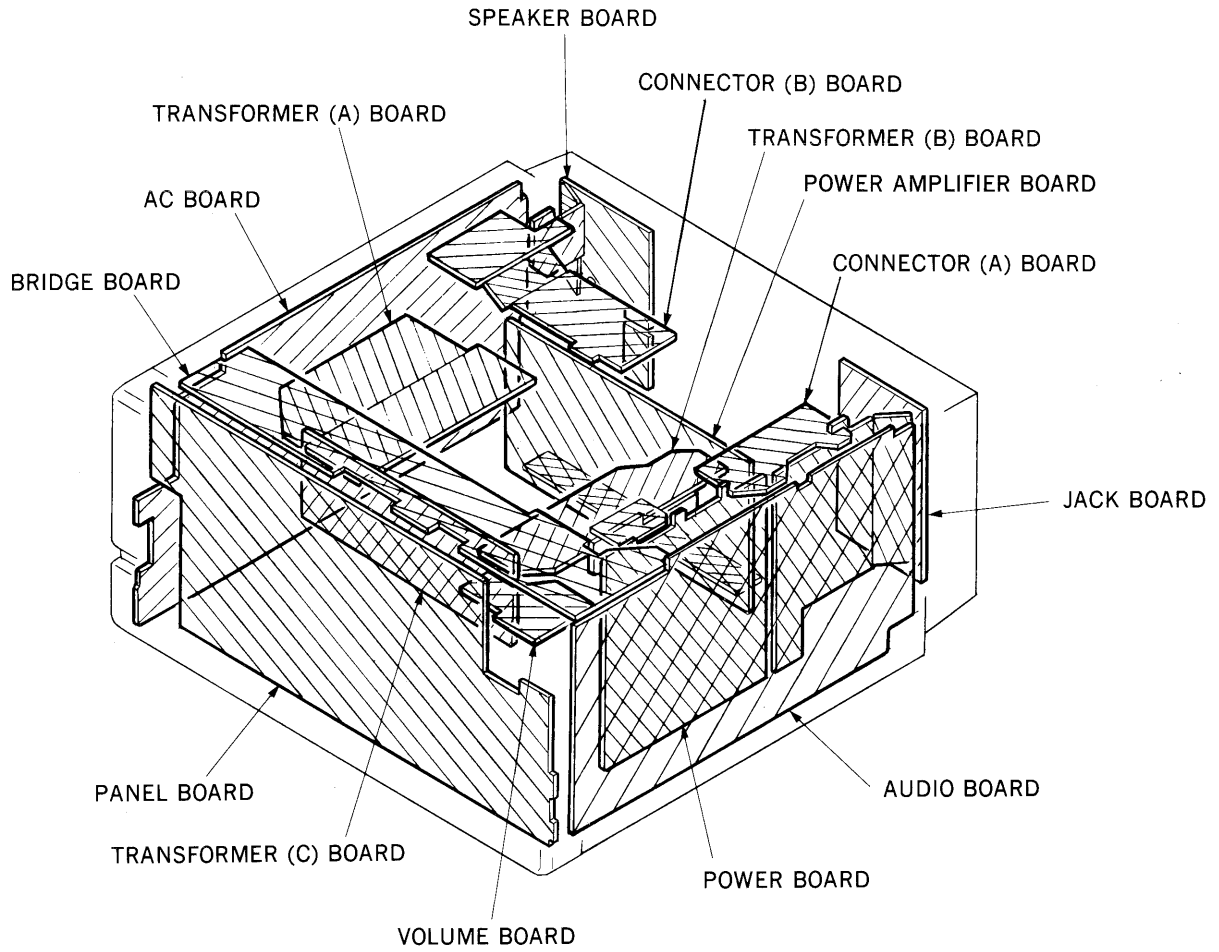

3-2. SEMICONDUCTOR LEAD LAYOUTS

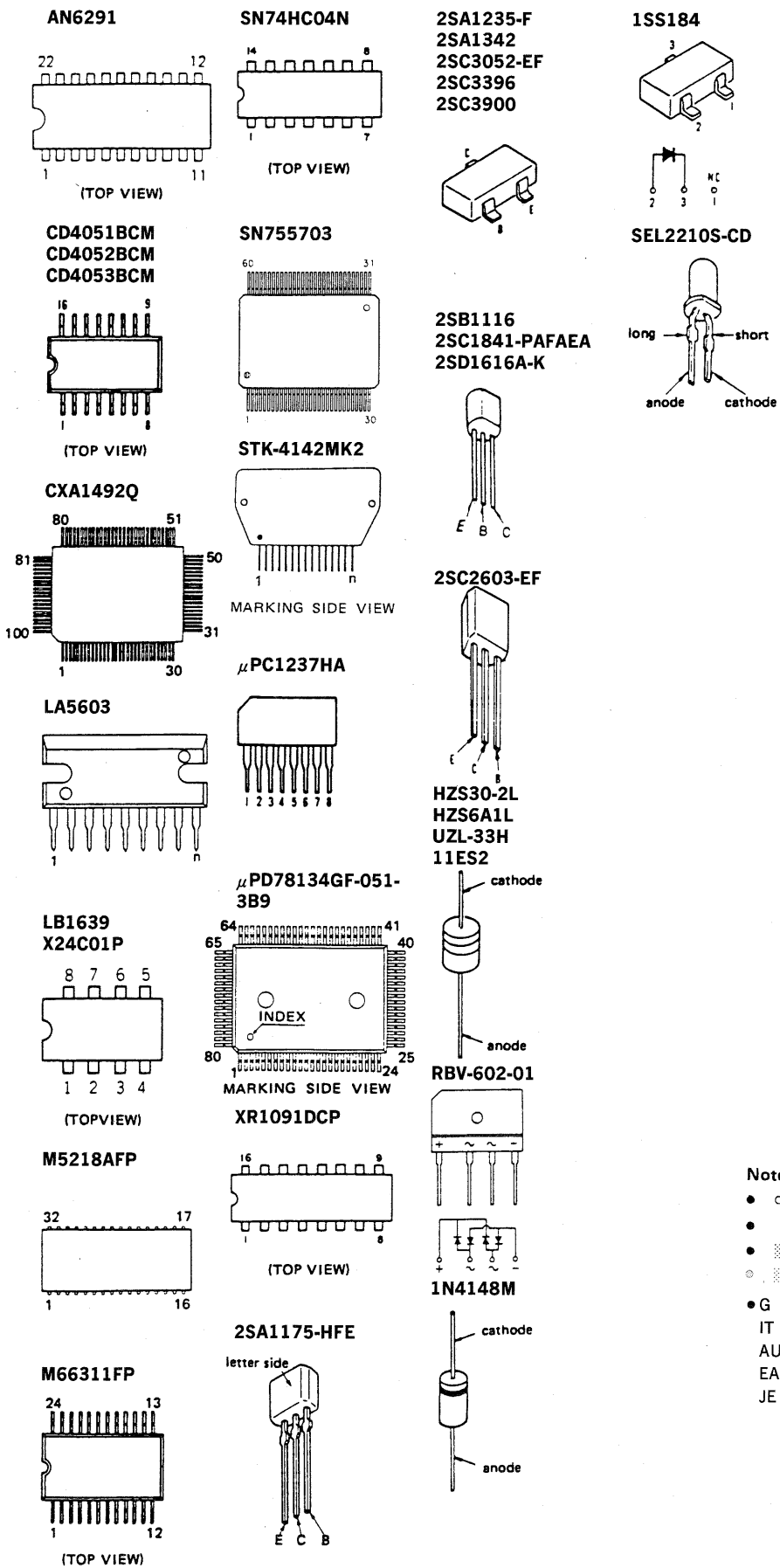

• Semiconductor Location

Ref. No.	Location
D231	E-3
D291	D-3
D292	D-3
D341	E-3
D342	D-3
D501	D-3
D502	C-3
D503	B-7
D504	B-3
D511	D-1
D512	D-1
D541	C-3
D601	B-3
IC101	B-8
IC102 (*1)	C-8
IC103	E-6
IC201	D-4
IC301	D-6
IC302	D-7
IC303	D-8
IC501	C-2
IC502	D-2
IC503	E-1
IC504	D-2
IC601	B-4
Q231	E-3
Q232	E-3
Q291	C-4
Q292	C-4
Q311	D-8
Q341	D-7
Q342	E-3
Q361	D-7
Q391	D-7
Q501	C-3
Q502	B-2
Q504	C-3
Q506	B-2
Q507	B-3
Q601	B-5
Q651	B-5

*1: Use on E, Australian, Saudi Arabia and Tourist model.

- Note:
- : parts extracted from the component side.
 - : Through hole.
 - ▨ : Pattern on the side which is seen.
 - (with dot) : Pattern of the rear side.
 - G : Germany model
 - IT : Italian model
 - AUS : Australian model
 - EA : Saudi Arabia model
 - JE : Tourist model

3-3. PRINTED WIRING BOARD—AUDIO SECTION—

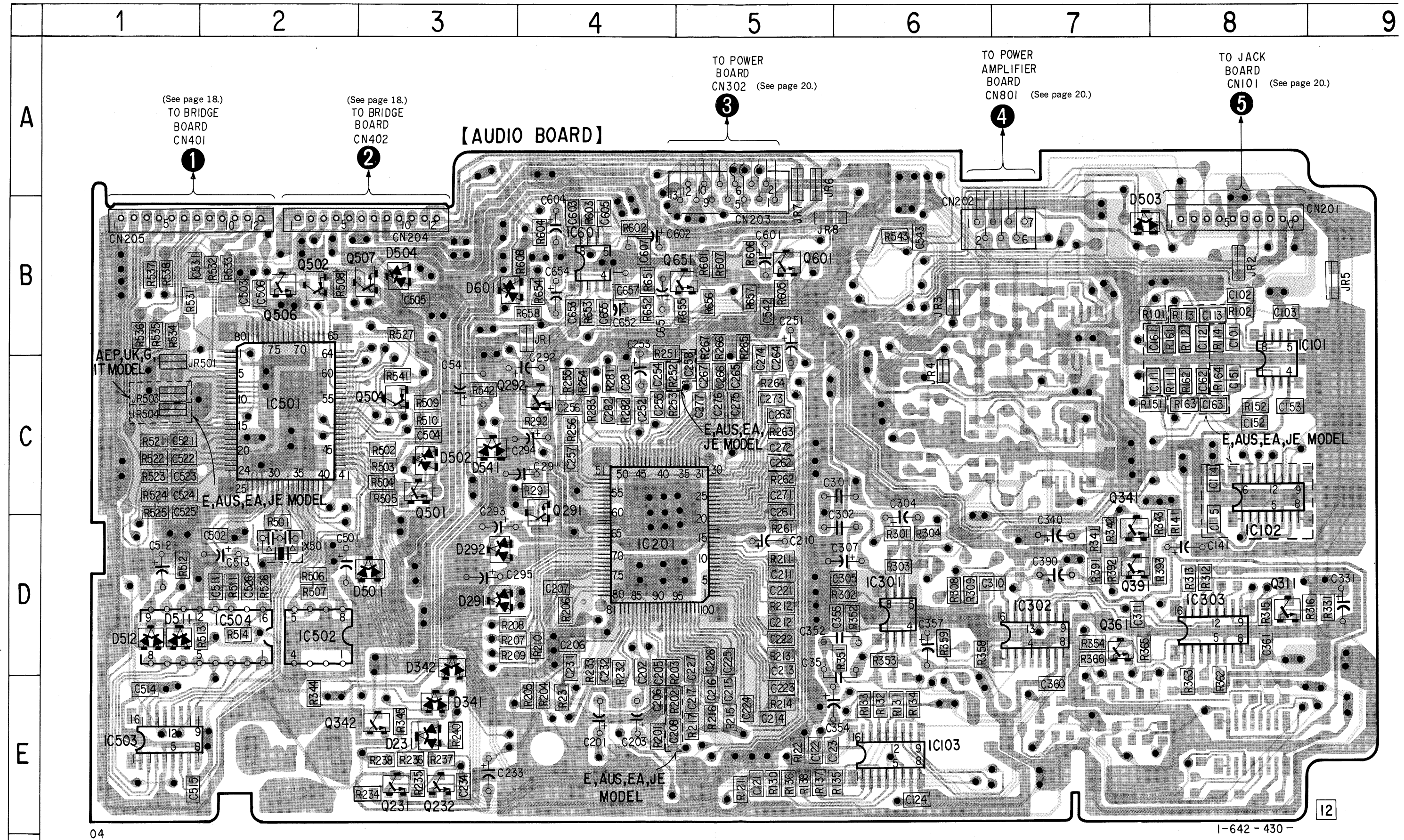

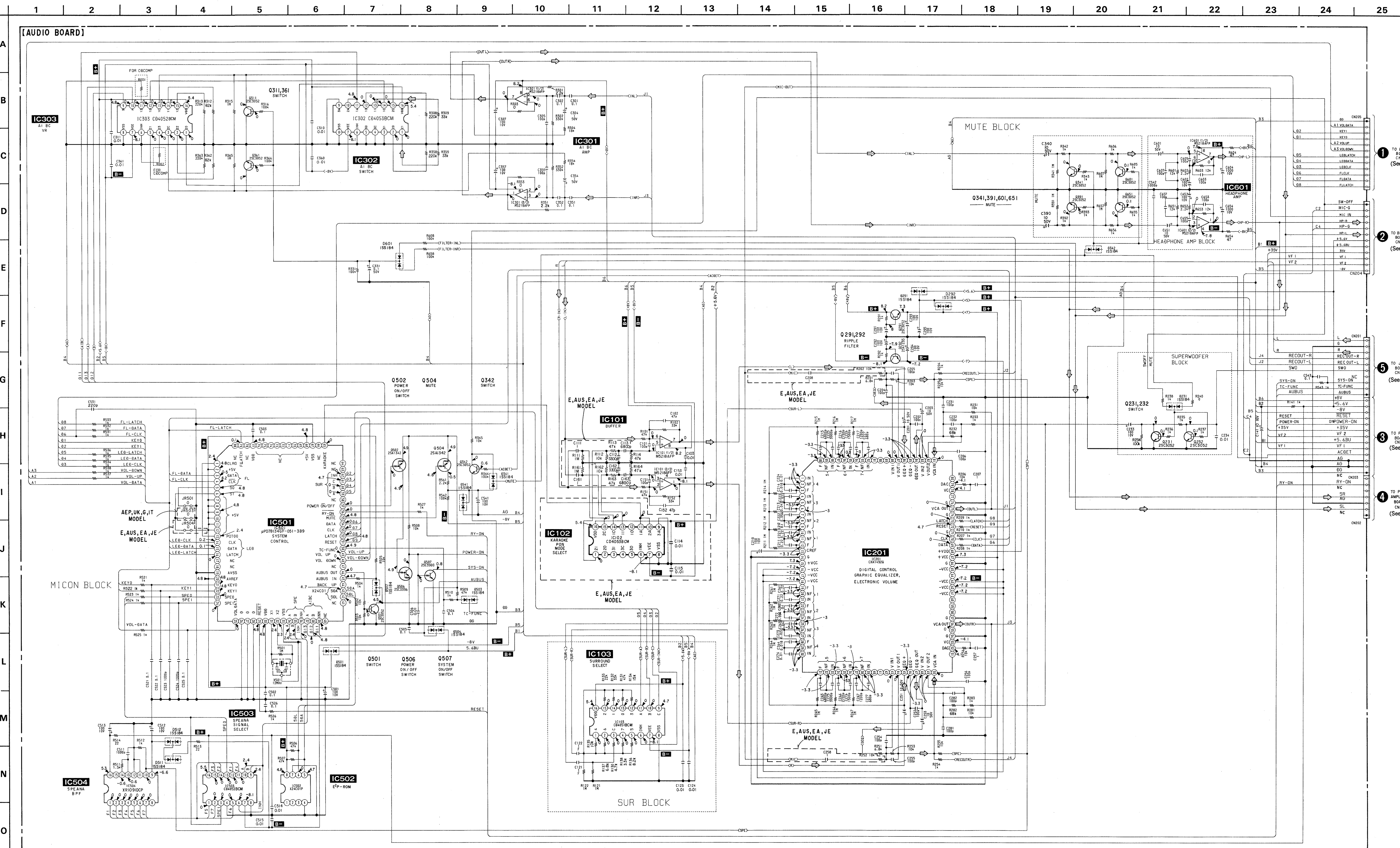

1 TO BRIDGE BOARD CN205 (See page 13.)
 2 TO BRIDGE BOARD CN202 (See page 14.)
 3 TO POWER BOARD CN203 (See page 22.)
 4 TO POWER AMPLIFIER BOARD CN204 (See page 22.)
 5 TO JACK BOARD CN201 (See page 23.)

Note:
 • All capacitors are in µF unless otherwise noted. pF: µF
 50WV or less are not indicated except for electrolytics and tantalums.
 • All resistors are in Ω and 1/4W or less unless otherwise specified.
 • Δ : internal component.
 • B+ : B+ Line
 • B- : B- Line
 • Voltage is dc with respect to ground under no-signal conditions.
 • no mark: SYSTEM POWER ON
 • Voltages are taken with a VOM (Input Impedance 10MΩ). Voltage variations may be noted due to normal production tolerances.
 • Signal path.
 • TUNER
 • G : Germany model
 • IT : Italian model
 • AUS : Australian model
 • EA : Saudi Arabia model
 • JE : Tourist model

3-6. PRINTED WIRING BOARDS—AC/VOLUME SECTION— • Refer to page 6 for Semiconductor Lead Layouts.

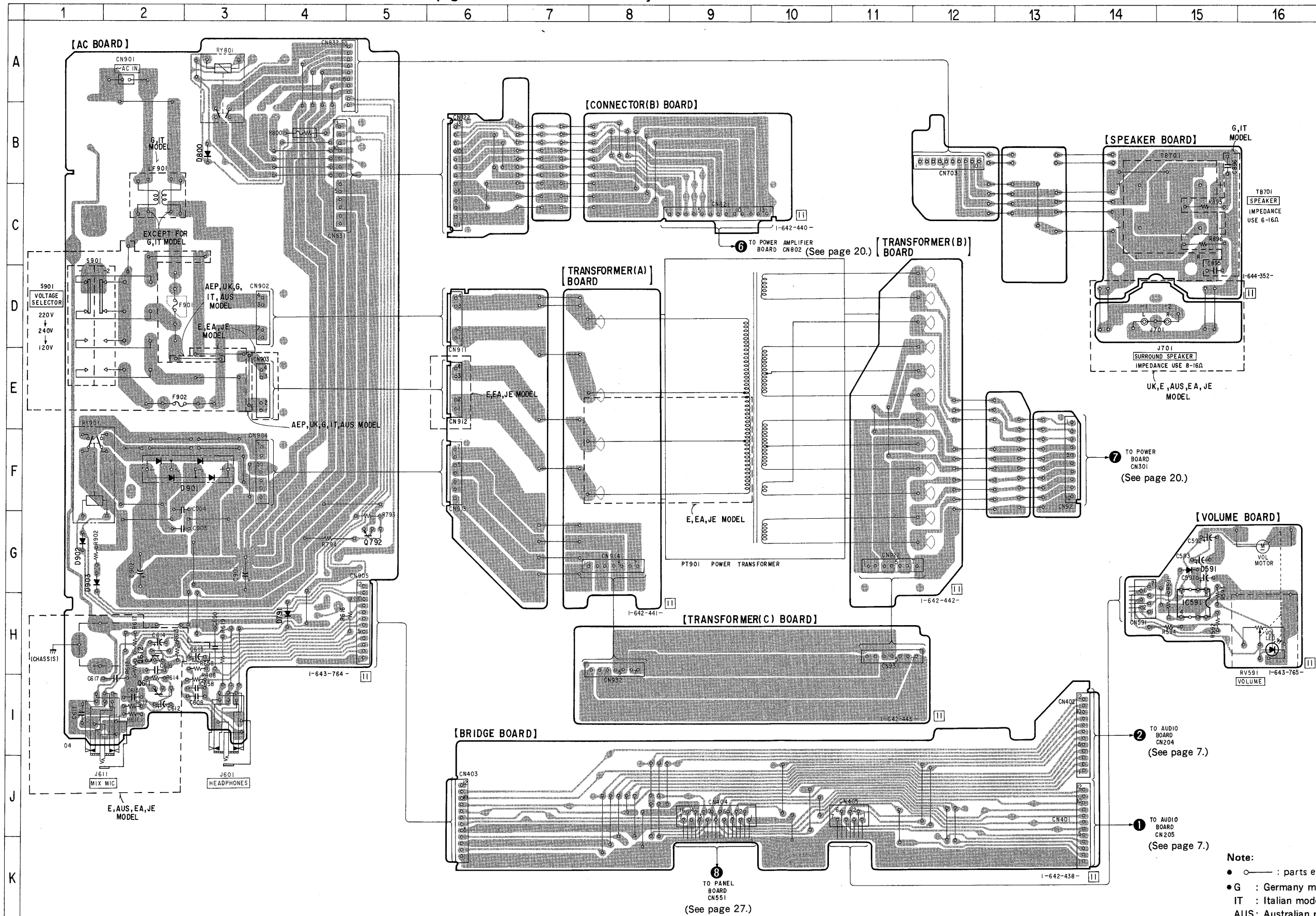

• Semiconductor Location

Ref. No.	Location
D591	G-15
D791	H-4
D800	B-3
D901	F-3
D902	G-1
D903	G-1
IC591	H-15
Q611 (* 1)	I-2
Q612 (* 1)	H-2
Q792	G-5

* 1 : Use on E, Australian, Saudi Arabia and Tourist model.

Note:

- ○ : parts extracted from the component side.
- G : Germany model
- IT : Italian model
- AUS : Australian model
- EA : Saudi Arabia model
- JE : Tourist model

● Semiconductor Location

Ref. No.	Location
D801	C-4
D851	C-4
D911	D-10
D912	C-10
D913	D-10
D914	C-10
D931	B-8
D932	B-8
D941	B-7
D942	C-8
D943	D-9
D944	B-8
D951	B-7
D952	C-7
D953	D-7
D961	B-10
D962	B-10
IC701	B-4
IC801	E-3
IC901	C-9
IC902	B-7
Q701	B-4
Q781	A-4
Q801	D-4
Q851	D-4
Q921	C-9
Q941	C-8
Q942	D-8
Q943	D-8
Q951	C-7
Q961	B-10

Note:

- ○ : parts extracted from the component side.
- G : Germany model
- IT : Italian model
- AUS : Australian model
- EA : Saudi Arabia model
- JE : Tourist model

3-7. PRINTED WIRING BOARDS—POWER/POWER AMPLIFIER SECTION— ● Refer to page 6 for Semiconductor Lead Layouts.

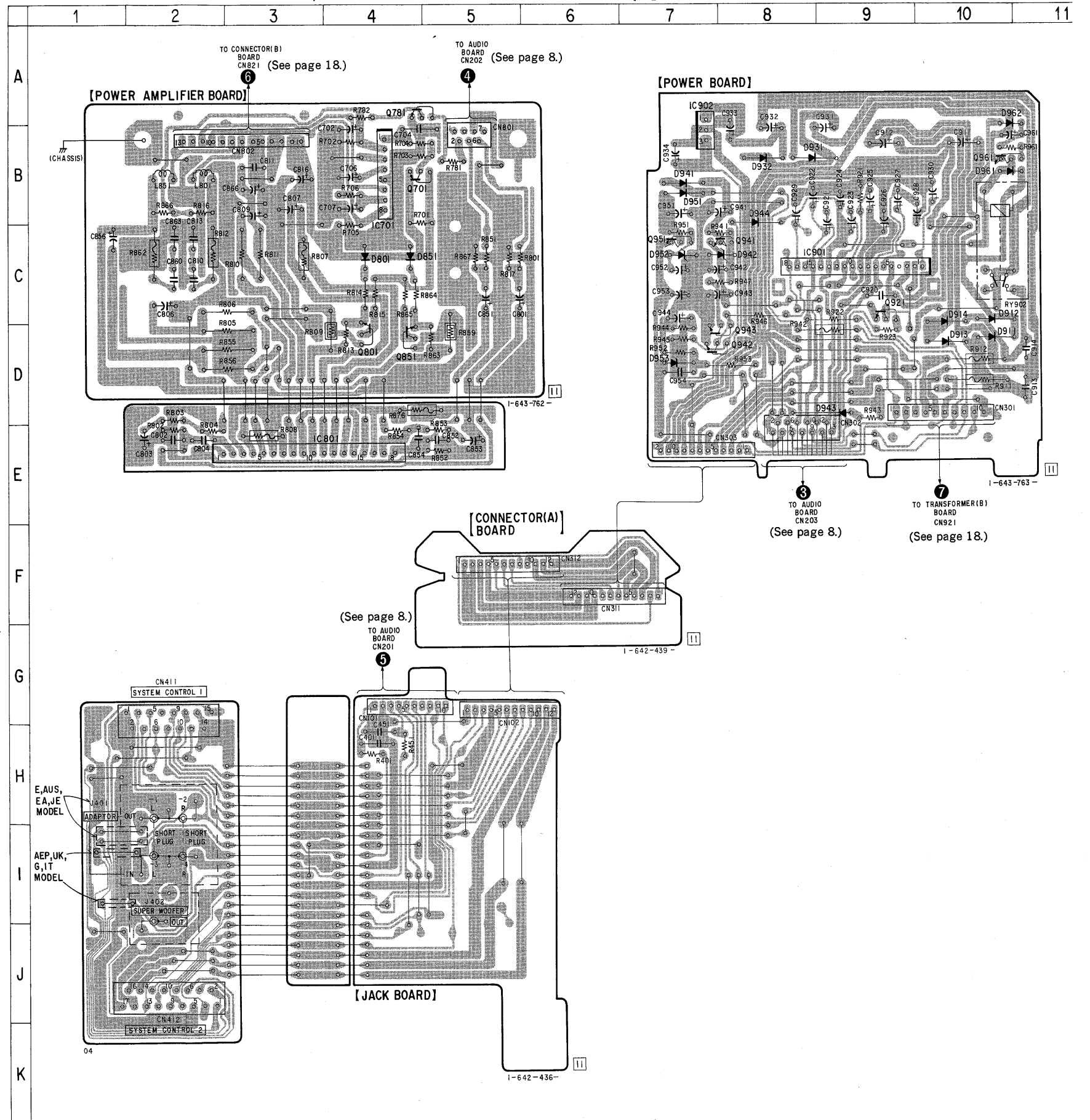

1 2 3 4 5 6 7 8 9 10 11 12 13 14 15 16 17 18 19 20

A
B
C
D
E
F
G
H
I
J
K
L
M
N
O

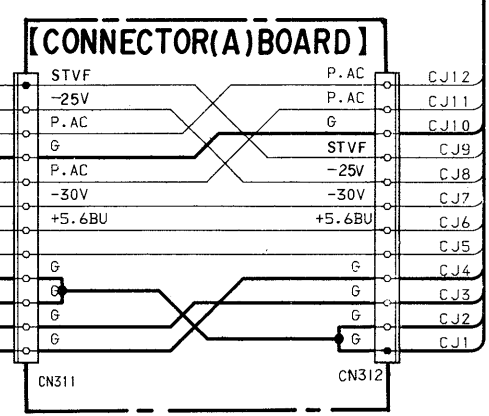
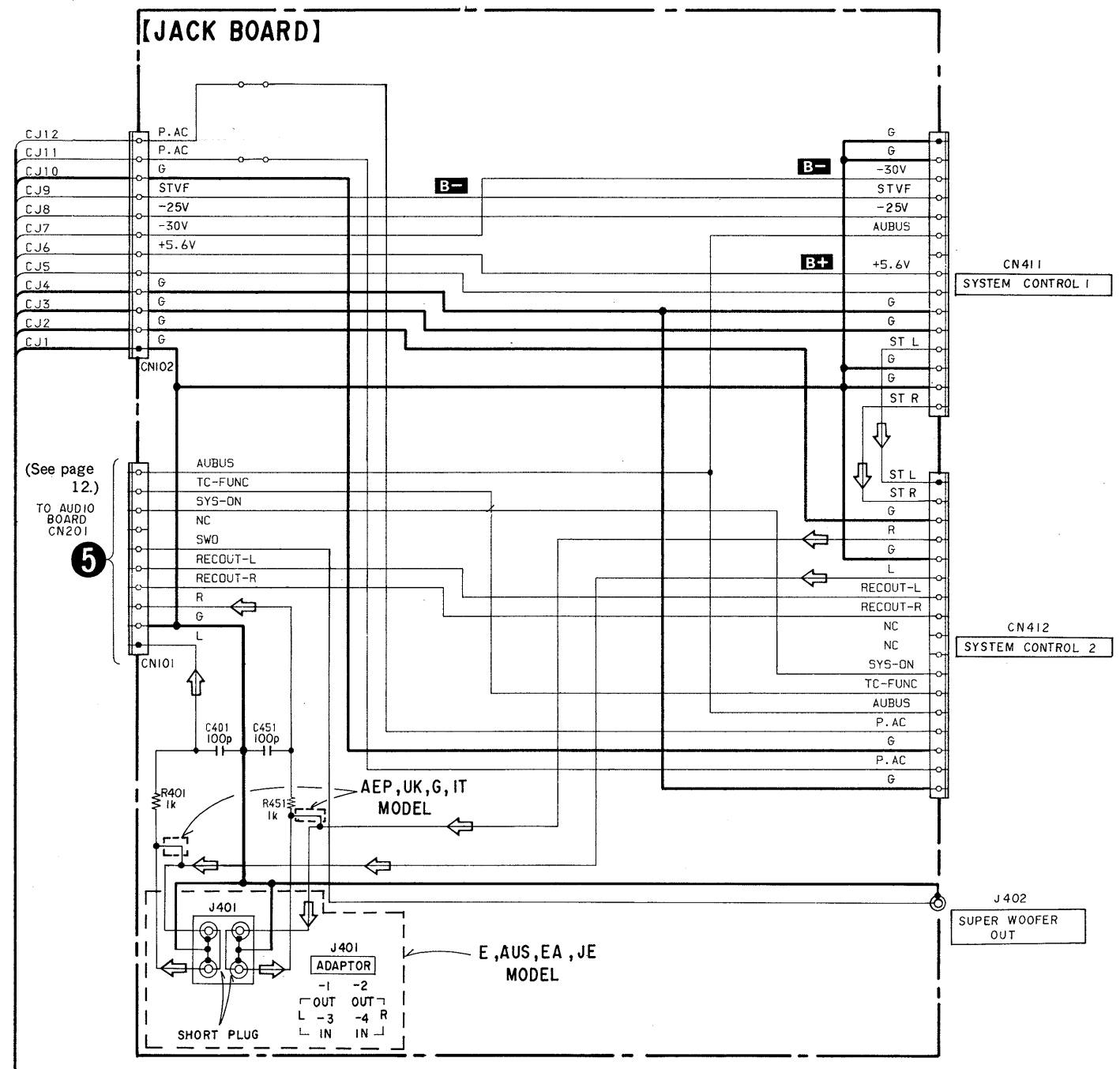
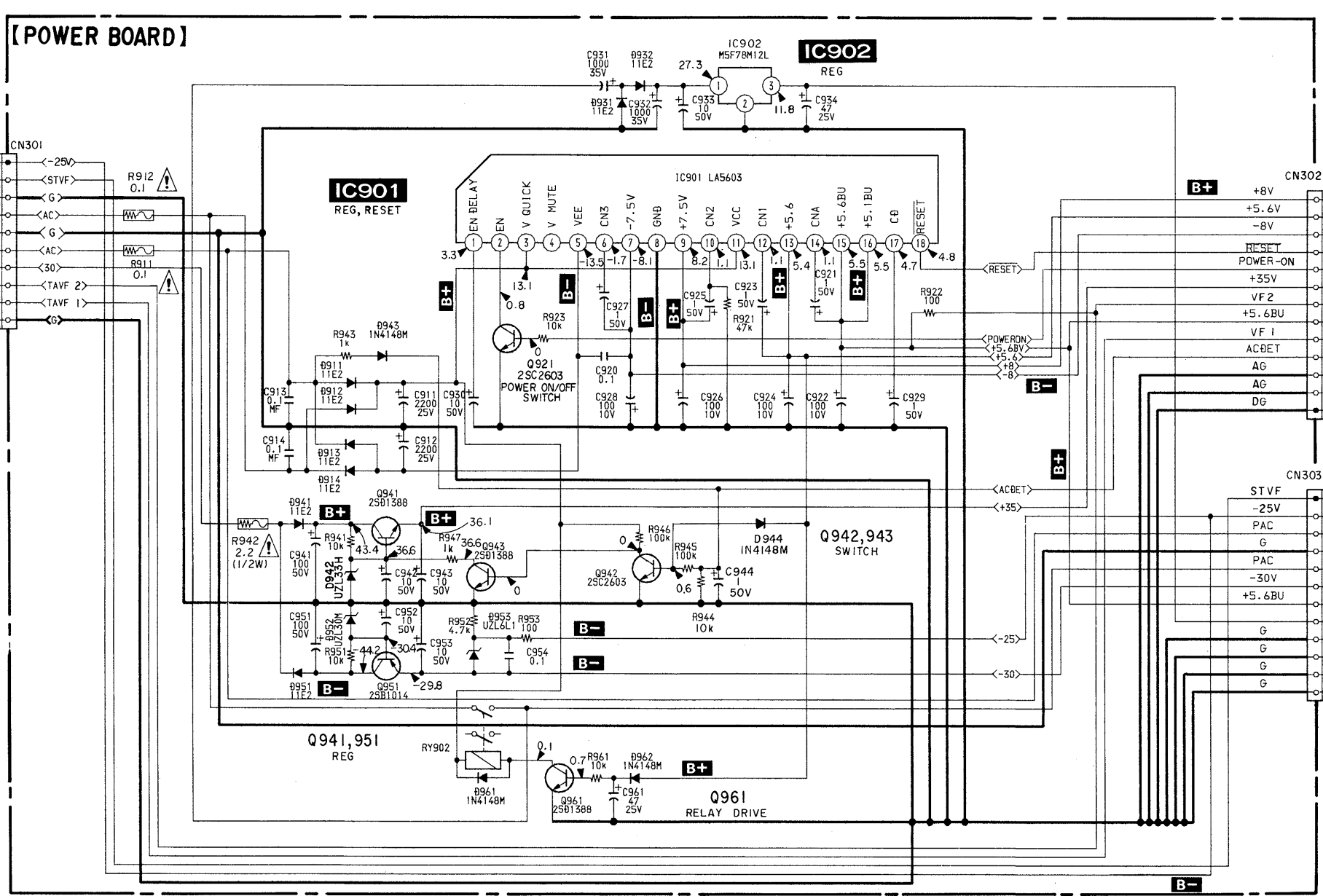
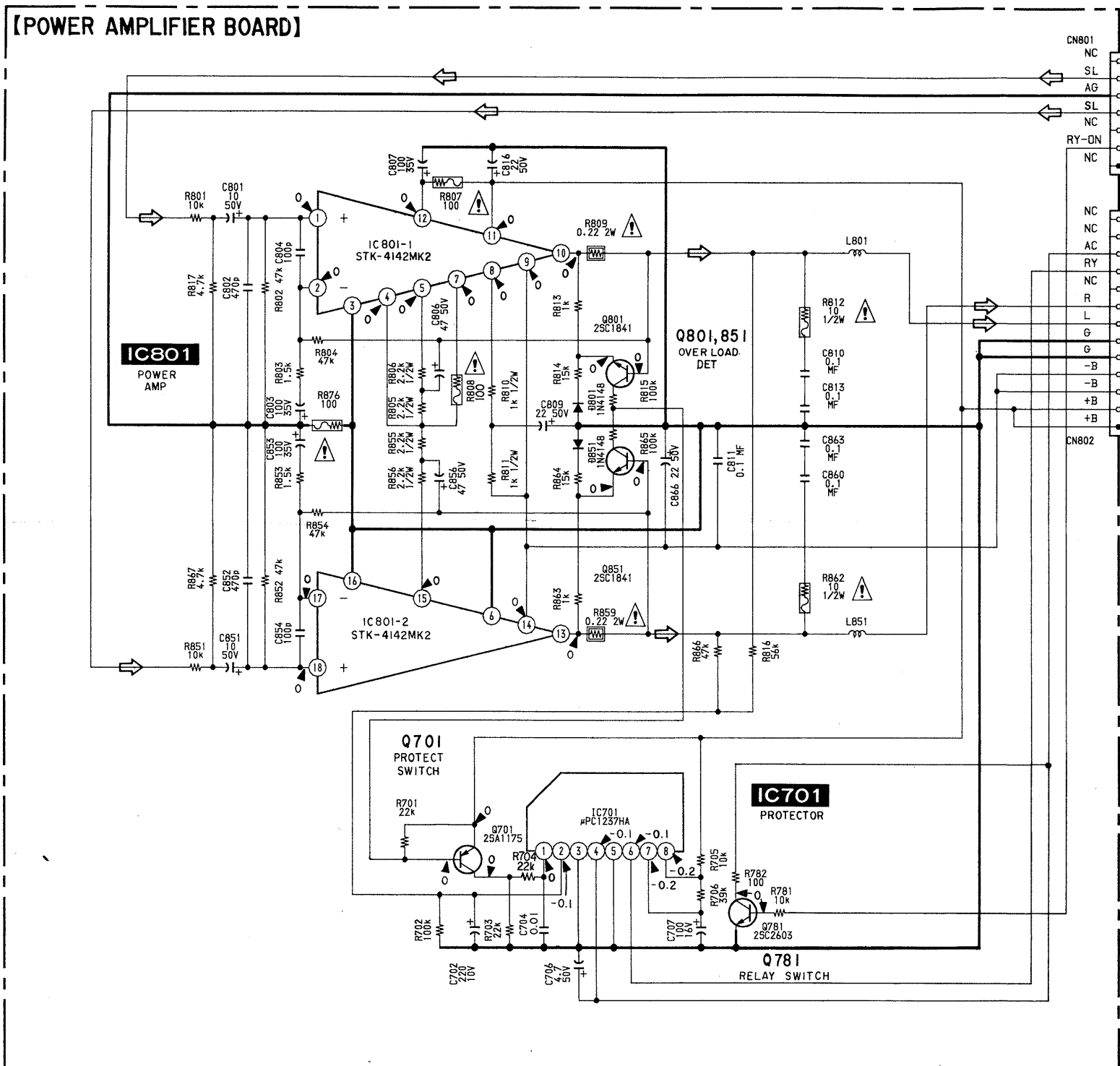

4 TO AUDIO BOARD CN202 (See page 12.)

6 TO CONNECTOR(B) BOARD CN821 (See page 15.)

5 TO AUDIO BOARD CN201 (See page 12.)

3 TO AUDIO BOARD CN203 (See page 12.)

7 TO TRANSFORMER(B) BOARD CN921 (See page 14.)

- Note:**
- All capacitors are in μF unless otherwise noted. pF : μpF 50WV or less are not indicated except for electrolytics and tantalums.
 - All resistors are in Ω and $\frac{1}{2}$ W or less unless otherwise specified.
 - \square : nonflammable resistor.
 - \square : fusible resistor.

Note: The components identified by mark Δ or dotted line with mark Δ are critical for safety. Replace only with part number specified.

- **B+**: B+ Line
- **B-**: B- Line
- Voltage is dc with respect to ground under no-signal conditions.
- no mark: SYSTEM POWER ON
- Voltages are taken with a VOM (Input Impedance 10M Ω). Voltage variations may be noted due to normal production tolerances.
- Signal path.
- \curvearrowright : TUNER
- G: Germany model
- IT: Italian model
- AUS: Australian model
- EA: Saudi Arabia model
- JE: Tourist model

3-9. SCHEMATIC DIAGRAM—PANEL SECTION— Refer to page 29 for IC Block Diagrams.

Note:

- All capacitors are in μF unless otherwise noted. pF : μF
- 50WV or less are not indicated except for electrolytics and tantalums.
- All resistors are in Ω and $\frac{1}{4}\text{W}$ or less unless otherwise specified.
- **B+** : B+ Line
- **B-** : B- Line

- Voltage is dc with respect to ground under no-signal conditions.
- no mark: SYSTEM POWER ON
- Voltages are taken with a VOM (Input Impedance $10\text{M}\Omega$).
- Voltage variations may be noted due to normal production tolerances.

- G : Germany model
- IT : Italian model
- AUS : Australian model
- EA : Saudi Arabia model
- JE : Tourist model

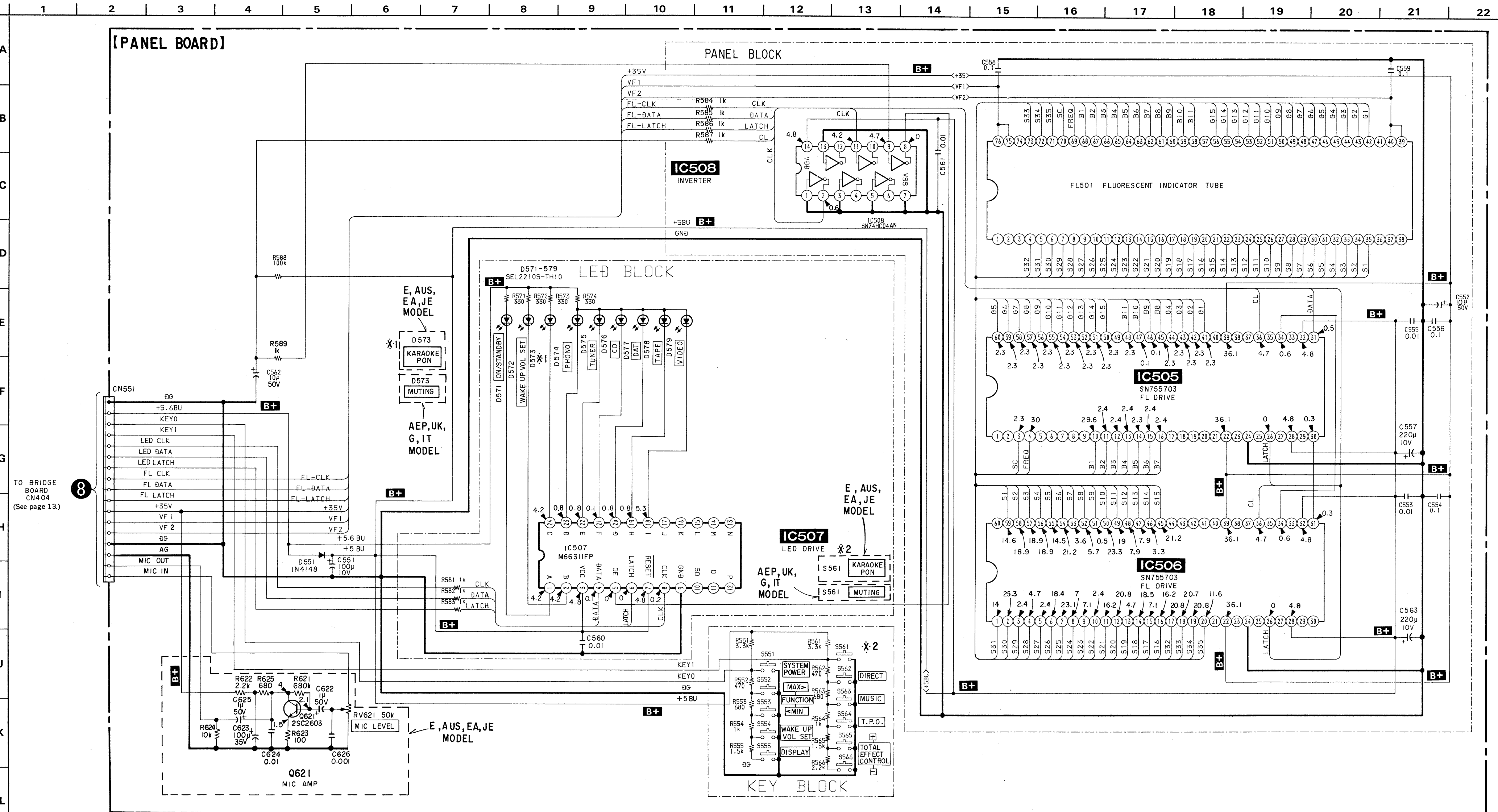

3-10. PRINTED WIRING BOARD—PANEL SECTION— • Refer to page 6 for Semiconductor Lead Layouts.

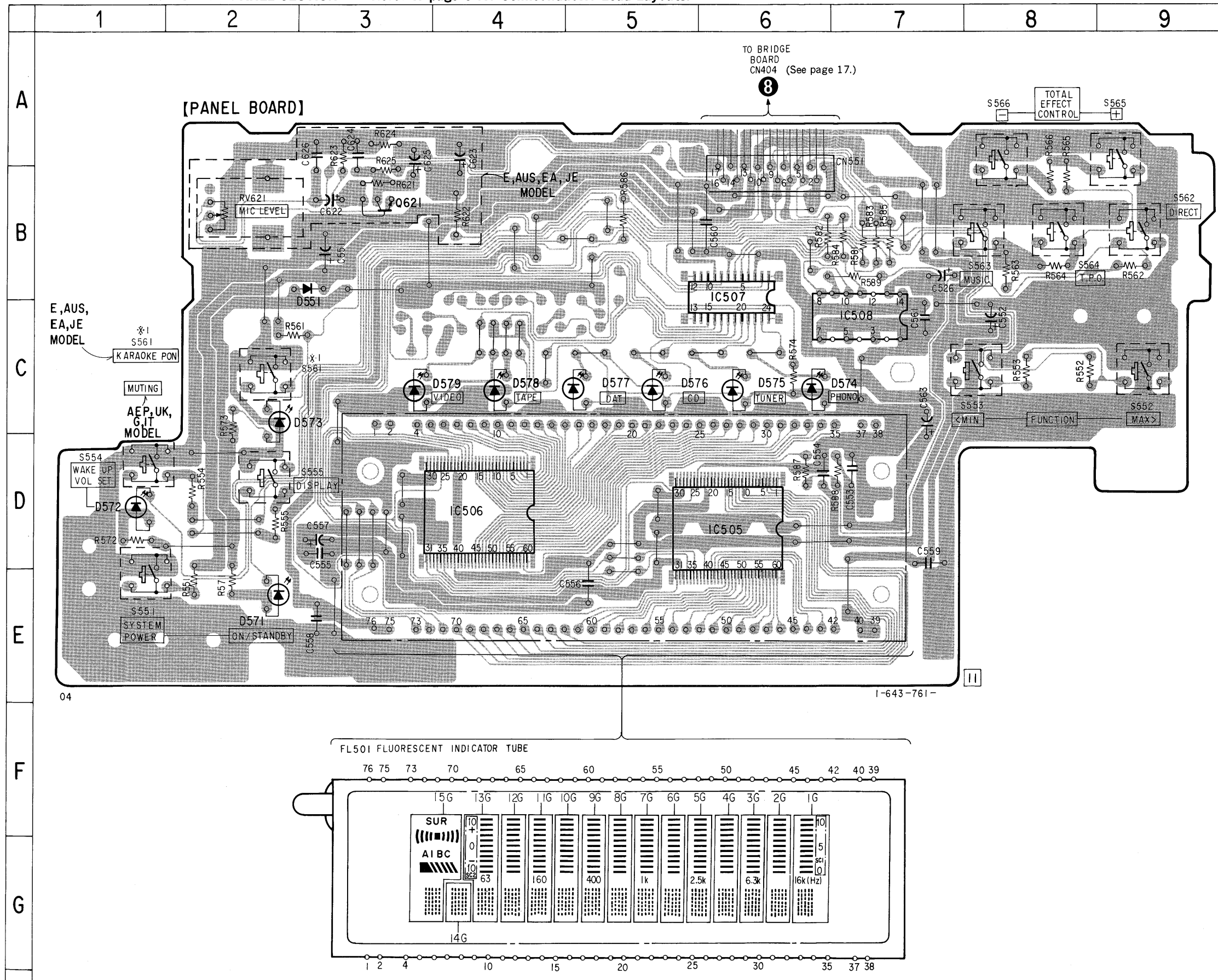

• Semiconductor Location

Ref. No.	Location
D551	B-3
D571	E-2
D572	D-1
D573	C-2
D574	C-6
D575	C-6
D576	C-5
D577	C-5
D578	C-4
D579	C-3
IC505	D-6
IC506	D-4
IC507	B-6
IC508	C-7
Q621 (* 1)	B-3

* 1 : Use on E, Australian, Saudi Arabia and Tourist model.

Note:

- — : parts extracted from the component side.
- G : Germany model
- IT : Italian model
- AUS : Australian model
- EA : Saudi Arabia model
- JE : Tourist model

• IC Block Diagrams
IC201 CXA1492Q

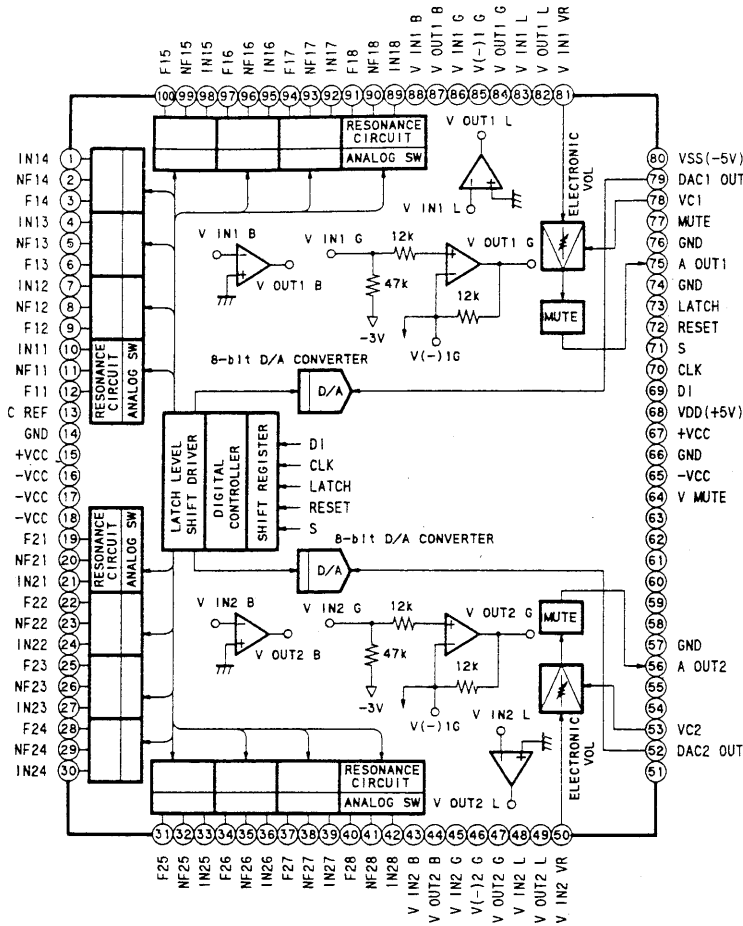

IC303, 503 CD4052BCM

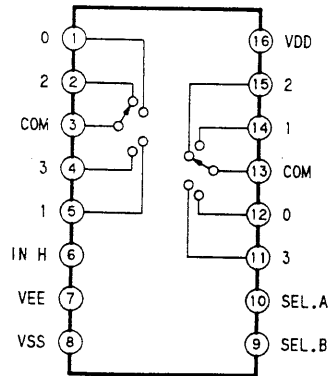

IC502 X24C01P

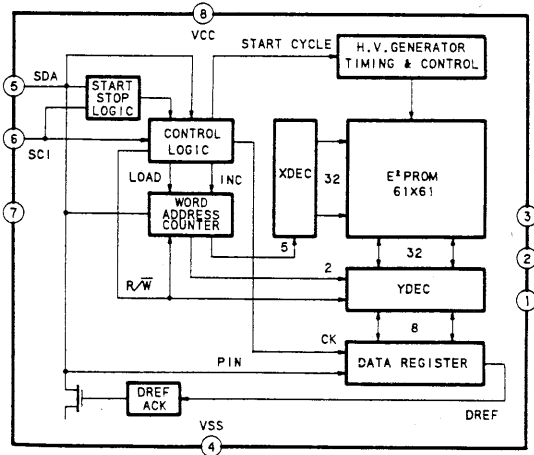

IC504 XR1091DCP

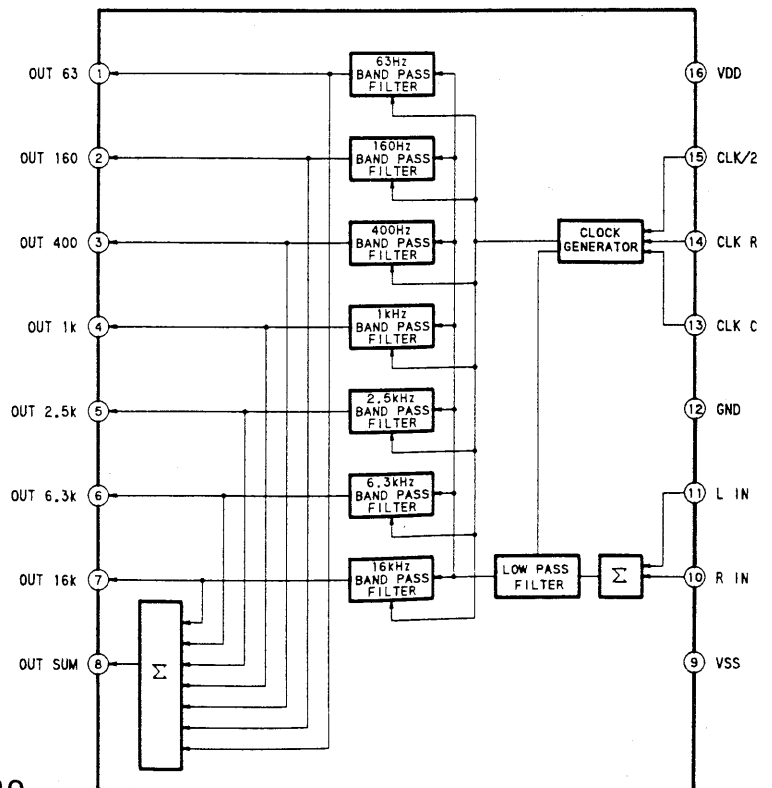

IC507 M66311FP

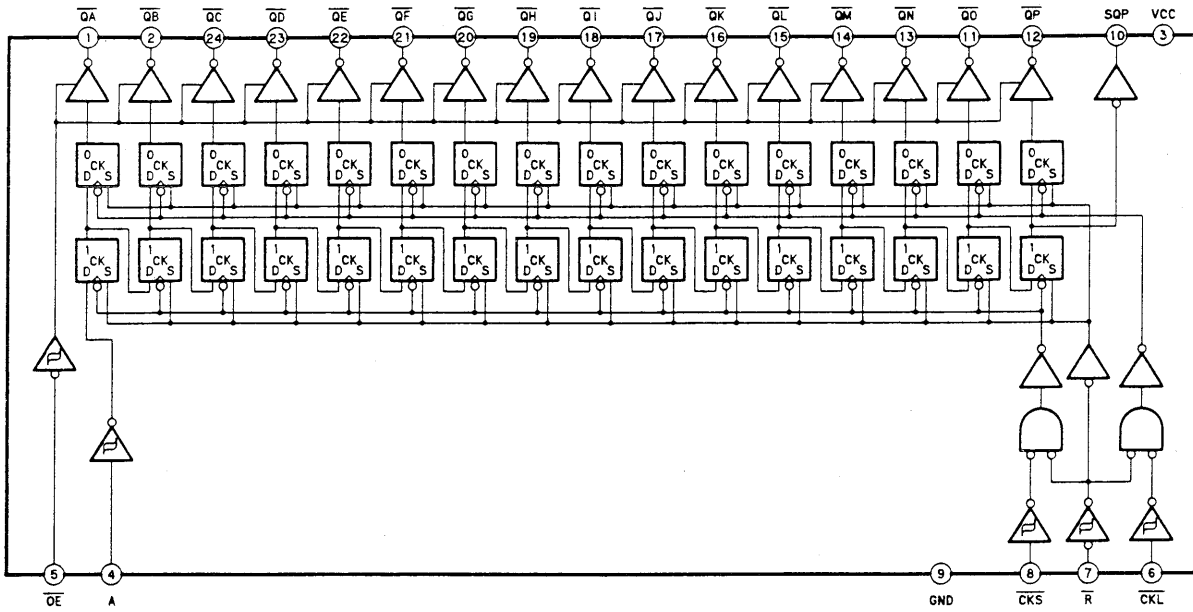

IC591 LB1639

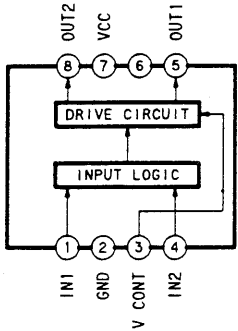

IC701 μ PC1237HA

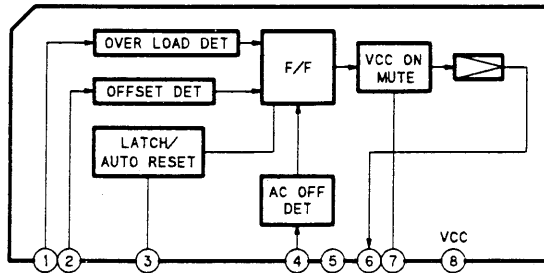

IC901 LA5603

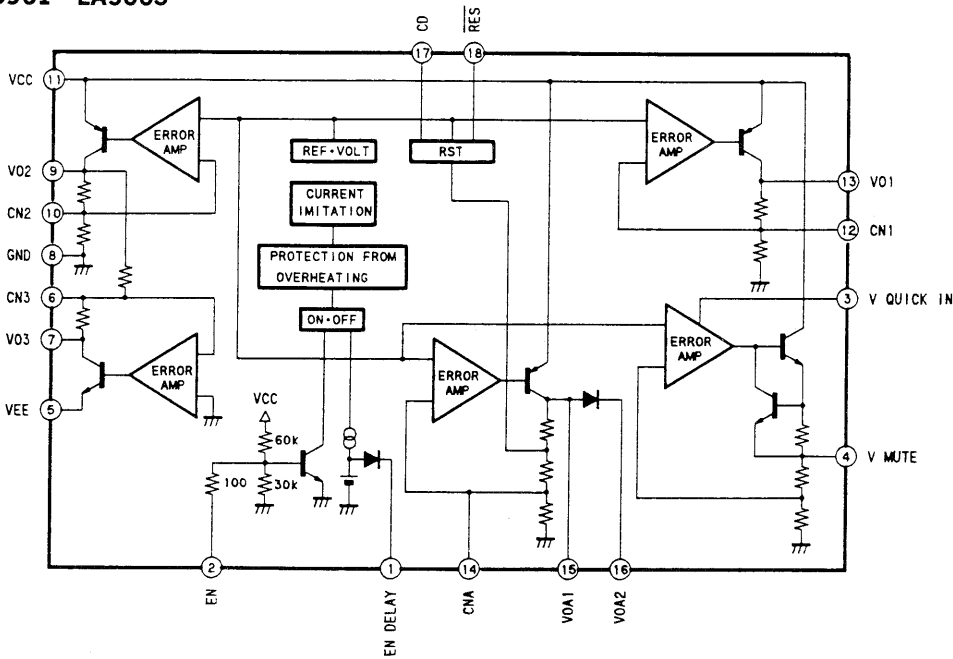

3-11. PIN FUNCTION OF IC501 (μ PD78134GF-051-3B9)

According to keying in or remote control signal, it sets the Graphic equalizer•electronic volume (IC201), KARAOKE PON (E, AUS, EA and JE model), AI BC, surround etc. and switches the LED and FL tube display and functions in the deck.

Pin No.	Pin name	I/O	Description
1	CLR0	I	Timer pulse input
2	+5V	I	Not in use with the equipment (+5V)
3	FL DATA	O	Serial data output to the FL tube driver (IC505, 506)
4	FL CLK	O	Data transfer clock output to the FL tube driver (IC505, 506)
5	S0	I	Input port for model selection. Connected to GND with the equipment.
6	S1	I	Input port for model selection. Connected to GND (AEP, UK, G and IT model) or +5V (E, AUS, EA and JE model) with the equipment.
7-12	+5V	I	Not in use with the equipment (+5V)
13	POT00	O	Timer pulse output (about 400 μ sec)
14	LED CLK	O	Data transfer clock output to the LED driver (IC507)
15	LED DATA	O	Serial data output to LED driver (IC507)
16	LED LATCH	O	Data latch output to the LED driver (IC507)
17, 18	NC	—	Not in use with the equipment (open)
19	AVSS	—	Analog system power terminal (GND)
20	AVREF	I	Analog port reference voltage input (+5V)
21, 22	KEY0, 1	I	Key input (Analog)* 1
23, 24	SPE0, 1	I	Spectrum analysis data input (analog)
25	VOL DATA	I	Volume position data input (analog)
26-28	G	—	Not in use with the equipment (GND)
29	RESET	I	System reset input. "L" : reset
30	VDD	—	Power terminal (+5V)
31, 32	X1, X2	—	Crystal connection terminal for system clock oscillation
33	VSS	—	Power terminal (GND)
34	SPE A	O	Spectrum analysis data input switch A
35	SPE B	O	Spectrum analysis data input switch B
36	SPE INH	O	Spectrum analysis data input switch inhibit
37	AI BC A	O	AI BC output switch A
38	AI BC B	O	AI BC output switch B
39	AI BC INH	O	AI BC output switch inhibit
40, 41	NC	—	Not in use with the equipment (open)
42	SDL	O	Clock output to E ² P-ROM (IC502)
43	SDA	I/O	Data input/output (user preset memory data, etc.) with E ² P-ROM (IC502)
44	BACK UP	—	Not in use with the equipment (open)
45	AU BUS IN	I	Audio bus input
46	AU BUS OUT	O	Audio bus output (tuner power ON/OFF and instruction to the function switch microcomputer in the deck)
47	NC	—	Not in use with the equipment (open)
48	VOL DOWN	O	DOWN signal output of the volume motor (RV591)
49	VOL UP	O	UP signal output of the volume motor (RV591)
50	TC-FUNC	I	Request of audio bus (FUNCTION data) from the function switch microcomputer in the deck (TC-H3700)
51	RESET	O	Reset output to the Graphic equalizer•electronic volume (IC201). "L" : reset
52	LATCH	O	Data latch output to the Graphic equalizer•electronic volume (IC201)

- G : Germany model
- IT : Italian model
- AUS: Australian model
- EA : Saudi Arabia model
- JE : Tourist model

Pin No.	Pin name	I/O	Description
53	CLK	O	Data transfer clock output to the Graphic equalizer•electronic volume (IC201)
54	DATA	O	Serial data output to the Graphic equalizer•electronic volume (IC201)
55	MUTE	O	Mute output
56	RY-ON	O	Speaker relay control
57	POWER ON/OFF	O	Power (IC901) output control. "L" : Power ON
58	NC	—	Not in use with the equipment (open)
59	SUR A	O	Surround control output switch A
60	SUR B	O	Surround control output switch B
61	SUR C	O	Surround control output switch C
62	SUR INH	O	Surround control output switch inhibit
63, 64	NC	—	Not in use with the equipment (open)
65	KARAOKE	O	Not in use with the equipment (open) (AEP, UK, G and IT model) KARAOKE PON ON/OFF (IC302 (1/2)) control output. "H" : KARAOKE PON (E, AUS, EA and JE model)
66	NC	—	Not in use with the equipment (open)
67	VSS	—	Power terminal (GND)
68	+5V	I	Not in use with the equipment (+5V)
69—76	NC	—	Not in use with the equipment (open)
77	VDD	—	Power terminal (+5V)
78	NC	—	Not in use with the equipment (open)
79	FL LATCH	O	Data latch output to the FL tube driver (IC505, 506)
80	NC	—	Not in use with the equipment (open)

*1 Key input (analog port)

Voltage (V) Input port	0	0.63	1.3	2.0	2.6	3.2
Pin ① KEY 0	SYSTEM POWER S551	FUNCTION MAX> S552	FUNCTION <MIN S553	WAKE UP VOL SET S554	DISPLAY S555	—
Pin ② KEY1	* 1 MUTING * 2 KARAOKE PON S561	DIRECT S562	MUSIC S563	T. P. O. S564	TOTAL EFFECT+ S565	TOTAL EFFECT- S566

* 1 : Use on AEP, UK, G and IT model.

* 2 : Use on E, AUS, EA and JE model.

• G : Germany model

IT : Italian model

AUS : Australian model

EA : Saudi Arabia model

JE : Tourist model

SECTION 4 EXPLODED VIEW

NOTE:

- The mechanical parts with no reference number in the exploded views are not supplied.
- Items marked "*" are not stocked since they are seldom required for routine service. Some delay should be anticipated when ordering these items.

- -XX, -X mean standardized parts, so they may have some differences from the original one.

- Color Indication of Appearance Parts
Example:
KNOB, BALANCE (WHITE)..(RED)

Parts Color Cabinet's Color

- Hardware (# mark) list is given in the last of this parts list.

The components identified by mark or dotted line with mark are critical for safety. Replace only with part number specified.

- G : Germany model
- IT : Italian model
- AUS : Australian model
- EA : Saudi Arabia model
- JE : Tourist model

4-1. MAIN SECTION

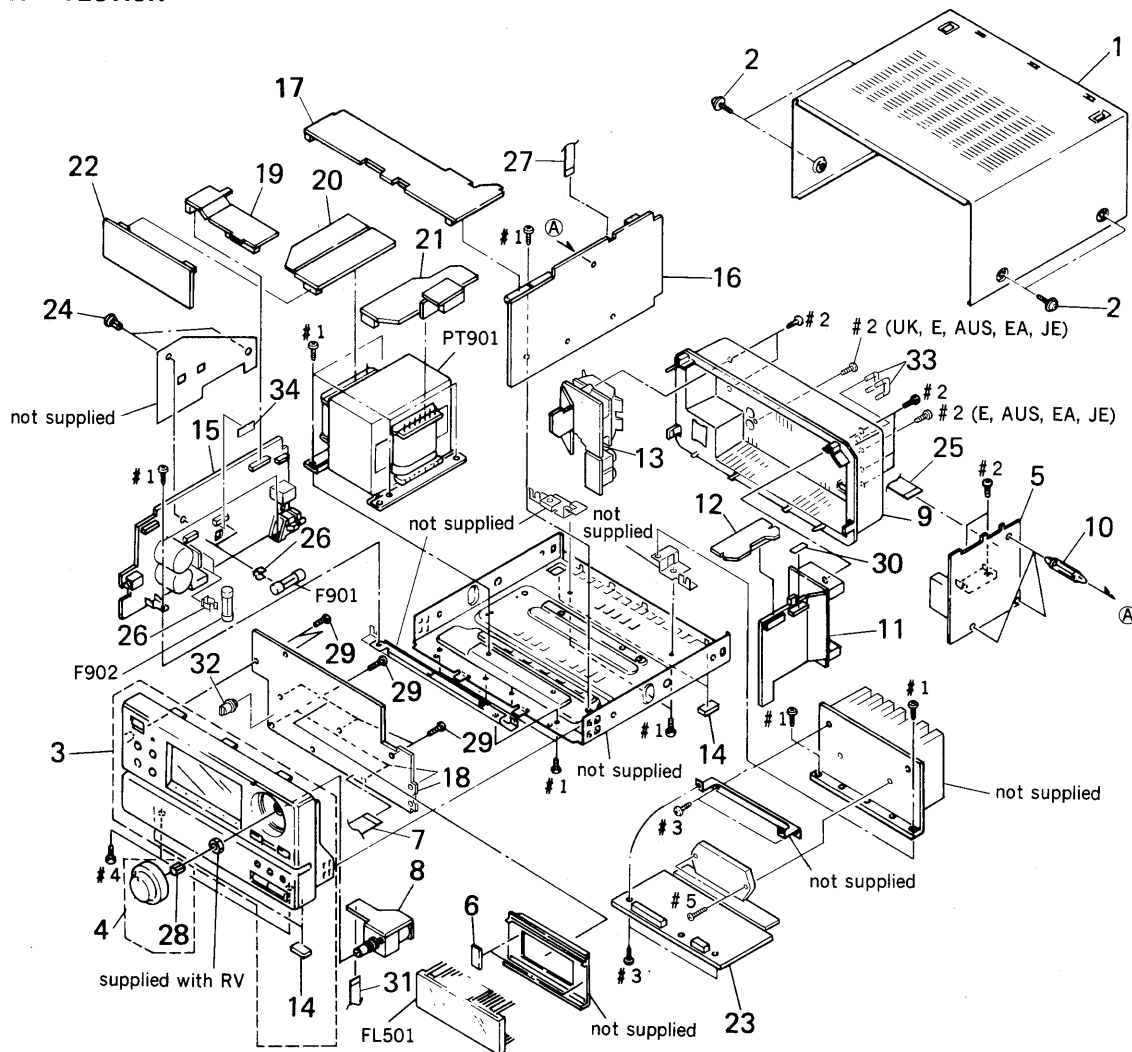

Ref. No.	Part No.	Description	Remark
* 1	4-944-522-21	CASE (K211522)	
2	3-363-099-01	SCREW (CASE +3X8 TP2)	
3	X-4942-490-1	PANEL ASSY, FRONT (E, AUS, EA, JE)	
3	X-4942-491-1	PANEL ASSY, FRONT (AEP, UK, G, IT)	
4	X-4942-471-1	KNOB (VOLUME) ASSY	
* 5	A-4347-380-A	POWER BOARD, COMPLETE	
* 6	4-932-810-11	CUSHION (FL)	
7	1-690-994-11	WIRE (FLAT TYPE) (17 CORE)	
* 8	1-643-765-11	VOLUME BOARD	
* 9	4-948-765-11	PANEL, BACK (E, AUS, EA, JE)	
* 9	4-948-765-21	PANEL, BACK (UK)	
* 9	4-948-765-32	PANEL, BACK (AEP, G, IT)	
* 10	4-385-948-01	HOLDER, PCB	
* 11	1-642-436-11	JACK BOARD	
* 12	1-642-439-11	CONNECTOR (A) BOARD	
* 13	1-644-352-11	SPEAKER BOARD	
14	4-930-336-21	FOOT (FELT)	
* 15	A-4347-381-A	AC BOARD, COMPLETE (AEP, UK)	
* 15	A-4347-382-A	AC BOARD, COMPLETE (G, IT)	
* 15	A-4347-383-A	AC BOARD, COMPLETE (E, JE)	
* 15	A-4347-384-A	AC BOARD, COMPLETE (EA)	
* 15	A-4347-702-A	AC BOARD, COMPLETE (AUS)	
* 16	A-4347-374-A	AUDIO BOARD, COMPLETE (AEP, UK)	
* 16	A-4347-375-A	AUDIO BOARD, COMPLETE (G, IT)	
* 16	A-4347-376-A	AUDIO BOARD, COMPLETE (E, AUS, EA, JE)	
* 17	1-642-438-11	BRIDGE BOARD	

Ref. No.	Part No.	Description	Remark
* 18	A-4347-377-A	PANEL BOARD, COMPLETE (AEP, UK, G, IT)	
* 18	A-4347-705-A	PANEL BOARD, COMPLETE (E, AUS, EA, JE)	
* 19	1-642-440-11	CONNECTOR (B) BOARD	
* 20	1-642-441-11	TRANSFORMER (A) BOARD	
* 21	1-642-442-11	TRANSFORMER (B) BOARD	
* 22	1-642-443-11	TRANSFORMER (C) BOARD	
* 23	A-4347-378-A	POWER AMPLIFIER BOARD, COMPLETE (AEP, UK, E, AUS, EA, JE)	
* 23	A-4347-379-A	POWER AMPLIFIER BOARD, COMPLETE (G, IT)	
24	4-812-134-11	RIVET NYLON, 3.5	
25	1-690-993-11	WIRE (FLAT TYPE) (13 CORE)	
* 26	1-533-213-31	HOLDER, FUSE	
27	1-690-992-11	WIRE (FLAT TYPE) (7 CORE)	
28	3-703-466-00	SPRING (6600)	
29	4-928-635-01	SCREW, +BV (2. 6X8) TAPPING	
30	9-911-835-XX	SPACER	
31	1-590-240-11	WIRE, FLAT TYPE (7 CORE)	
32	4-950-897-01	KNOB (MIC LEVEL) (E, AUS, EA, JE)	
33	1-535-706-11	PLUG, JUMPER (E, AUS, EA, JE)	
34	3-701-947-12	LABEL (T1. 25A), FUSE (AUS)	
△F901	1-532-285-00	FUSE, TIME-LAG (T1. 25A)	
△F902	1-532-286-00	FUSE, TIME-LAG (T2. 5A) (E, EA, JE)	
FL501	1-519-720-11	INDICATOR TUBE, FLUORESCENT	
△PT901	1-450-896-11	TRANSFORMER, POWER (AEP, G, IT)	
△PT901	1-450-897-11	TRANSFORMER, POWER (UK, AUS)	
△PT901	1-450-898-11	TRANSFORMER, POWER (E, EA, JE)	

SECTION 5
ELECTRICAL PARTS LIST

AC PANEL POWER
POWER AMPLIFIER VOLUME

NOTE:

- Due to standardization, replacements in the parts list may be different from the parts specified in the diagrams or the components used on the set.
- -XX and -X mean standardized parts, so they may have some difference from the original one.
- RESISTORS
All resistors are in ohms.
METAL: Metal-film resistor.
METAL OXIDE: Metal oxide-film resistor.
F: nonflammable

- Items marked "*" are not stocked since they are seldom required for routine service. Some delay should be anticipated when ordering these items.
- SEMICONDUCTORS
In each case, u: μ , for example:
uA.: μ A. uPA.: μ PA.
uPB.: μ PB. uPC.: μ PC. uPD.: μ PD.
- CAPACITORS
uF: μ F
- COILS
uH: μ H

The components identified by mark Δ or dotted line with mark. Δ are critical for safety. Replace only with part number specified.

When indicating parts by reference number, please include the board.

- G : Germany model
- IT : Italian model
- AUS : Australian model
- EA : Saudi Arabia model
- JE : Tourist model

Ref. No.	Part No.	Description	Remark
*	A-4347-381-A	AC BOARD, COMPLETE (AEP, UK)	
*	A-4347-382-A	AC BOARD, COMPLETE (G, IT)	
*	A-4347-383-A	AC BOARD, COMPLETE (E, JE)	
*	A-4347-384-A	AC BOARD, COMPLETE (EA)	
*	A-4347-702-A	AC BOARD, COMPLETE (AUS)	

*	A-4347-377-A	PANEL BOARD, COMPLETE (AEP, UK, G, IT)	
*	A-4347-705-A	PANEL BOARD, COMPLETE (E, AUS, EA, JE)	

*	A-4347-380-A	POWER BOARD, COMPLETE	

*	A-4347-378-A	POWER AMPLIFIER BOARD, COMPLETE (AEP, UK, E, AUS, EA, JE)	
*	A-4347-379-A	POWER AMPLIFIER BOARD, COMPLETE (G, IT)	

*	1-643-765-11	VOLUME BOARD	

*	1-533-213-31	HOLDER, FUSE	
*	4-932-810-11	CUSHION (FL)	
	7-685-647-79	SCREW +BVTP 3X10 TYPE2 IT-3	
< CAPACITOR >			
C551	1-124-443-00	ELECT 100uF 20%	10V
C552	1-124-261-00	ELECT 10uF 20%	50V
C553	1-161-379-00	CERAMIC 0.01uF 20%	25V
C554	1-164-159-11	CERAMIC 0.1uF	50V
C555	1-161-379-00	CERAMIC 0.01uF 20%	25V
C556	1-164-159-11	CERAMIC 0.1uF	50V
C557	1-126-923-11	ELECT 220uF 20%	10V
C558	1-164-159-11	CERAMIC 0.1uF	50V
C559	1-164-159-11	CERAMIC 0.1uF	50V
C560	1-161-379-00	CERAMIC 0.01uF 20%	25V
C561	1-161-379-00	CERAMIC 0.01uF 20%	25V
C562	1-124-261-00	ELECT 10uF 20%	50V
C563	1-126-923-11	ELECT 220uF 20%	10V
C591	1-124-443-00	ELECT 100uF 20%	10V
C592	1-124-907-11	ELECT 10uF 20%	50V
C593	1-124-907-11	ELECT 10uF 20%	50V
C608	1-161-379-00	CERAMIC 0.01uF 20%	25V (AEP, UK, E, AUS, EA, JE)
C608	1-164-159-11	CERAMIC 0.1uF	50V (G, IT)

Ref. No.	Part No.	Description	Remark
C611	1-162-294-31	CERAMIC 0.001uF 10%	50V (E, AUS, EA, JE)
C612	1-124-903-11	ELECT 1uF 20%	50V (E, AUS, EA, JE)
C613	1-162-294-31	CERAMIC 0.001uF 10%	50V (E, AUS, EA, JE)
C614	1-124-903-11	ELECT 1uF 20%	50V (E, AUS, EA, JE)
C615	1-124-443-00	ELECT 100uF 20%	10V (E, AUS, EA, JE)
C616	1-161-379-00	CERAMIC 0.01uF 20%	25V (E, AUS, EA, JE)
C617	1-164-159-11	CERAMIC 0.1uF	50V (E, AUS, EA, JE)
C622	1-124-903-11	ELECT 1uF 20%	50V (E, AUS, EA, JE)
C623	1-126-948-11	ELECT 100uF 20%	35V (E, AUS, EA, JE)
C624	1-161-379-00	CERAMIC 0.01uF 20%	25V (E, AUS, EA, JE)
C625	1-124-903-11	ELECT 1uF 20%	50V (E, AUS, EA, JE)
C626	1-162-294-31	CERAMIC 0.001uF 10%	50V (E, AUS, EA, JE)
C658	1-161-379-00	CERAMIC 0.01uF 20%	25V (AEP, UK, E, AUS, EA, JE)
C658	1-164-159-11	CERAMIC 0.1uF	50V (G, IT)
C690	1-164-159-11	CERAMIC 0.1uF	50V
C702	1-126-176-11	ELECT 220uF 20%	10V
C704	1-162-306-11	CERAMIC 0.01uF 20%	16V
C706	1-124-927-11	ELECT 4.7uF 20%	100V
C707	1-126-101-11	ELECT 100uF 20%	16V
C801	1-124-907-11	ELECT 10uF 20%	50V
C802	1-162-290-31	CERAMIC 470PF 10%	50V
C803	1-124-122-11	ELECT 100uF 20%	50V
C804	1-162-282-31	CERAMIC 100PF 10%	50V
C806	1-124-910-11	ELECT 47uF 20%	50V
C807	1-124-122-11	ELECT 100uF 20%	50V
C809	1-126-233-11	ELECT 22uF 20%	50V
C810	1-136-165-00	FILM 0.1uF 5%	50V
C811	1-136-165-00	FILM 0.1uF 5%	50V

AC

PANEL

POWER

POWER AMPLIFIER

VOLUME

Ref. No.	Part No.	Description		Remark
C813	1-136-165-00	FILM	0.1uF	5% 50V
C816	1-126-233-11	ELECT	22uF	20% 50V
C851	1-124-907-11	ELECT	10uF	20% 50V
C852	1-162-290-31	CERAMIC	470PF	10% 50V
C853	1-124-122-11	ELECT	100uF	20% 50V
C854	1-162-282-31	CERAMIC	100PF	10% 50V
C856	1-124-910-11	ELECT	47uF	20% 50V
C860	1-136-165-00	FILM	0.1uF	5% 50V
C863	1-136-165-00	FILM	0.1uF	5% 50V
C866	1-126-233-11	ELECT	22uF	20% 50V
C901	1-126-224-11	ELECT	4700uF	20% 42V
C902	1-126-224-11	ELECT	4700uF	20% 42V
C903	1-136-171-00	FILM	0.33uF	5% 50V
C904	1-136-171-00	FILM	0.33uF	5% 50V
C911	1-124-563-11	ELECT	2200uF	20% 25V
C912	1-124-563-11	ELECT	2200uF	20% 25V
C913	1-136-165-00	FILM	0.1uF	5% 50V
C914	1-136-165-00	FILM	0.1uF	5% 50V
C920	1-164-159-11	CERAMIC	0.1uF	50V
C921	1-124-903-11	ELECT	1uF	20% 50V
C922	1-124-443-00	ELECT	100uF	20% 10V
C923	1-124-903-11	ELECT	1uF	20% 50V
C924	1-124-443-00	ELECT	100uF	20% 10V
C925	1-124-903-11	ELECT	1uF	20% 50V
C926	1-124-443-00	ELECT	100uF	20% 10V
C927	1-124-903-11	ELECT	1uF	20% 50V
C928	1-124-443-00	ELECT	100uF	20% 10V
C929	1-124-903-11	ELECT	1uF	20% 50V
C930	1-124-907-11	ELECT	10uF	20% 50V
C931	1-126-105-11	ELECT	1000uF	20% 35V
C932	1-126-105-11	ELECT	1000uF	20% 35V
C933	1-124-907-11	ELECT	10uF	20% 50V
C934	1-124-477-11	ELECT	47uF	20% 25V
C941	1-124-122-11	ELECT	100uF	20% 50V
C942	1-124-907-11	ELECT	10uF	20% 50V
C943	1-124-907-11	ELECT	10uF	20% 50V
C944	1-124-903-11	ELECT	1uF	20% 50V
C951	1-124-122-11	ELECT	100uF	20% 50V
C952	1-124-907-11	ELECT	10uF	20% 50V
C953	1-124-907-11	ELECT	10uF	20% 50V
C954	1-164-159-11	CERAMIC	0.1uF	50V
C961	1-124-477-11	ELECT	47uF	20% 25V

< CONNECTOR >

- * CN301 1-569-505-11 PIN, CONNECTOR 10P
- * CN302 1-568-832-11 SOCKET, CONNECTOR 13P
- CN303 1-573-826-11 CONNECTOR, BOARD TO BOARD 12P
- * CN551 1-568-836-11 SOCKET, CONNECTOR 17P
- * CN591 1-568-826-11 SOCKET, CONNECTOR 7P

Ref. No.	Part No.	Description	Remark
* CN801	1-568-850-11	SOCKET, CONNECTOR 7P	
* CN802	1-573-087-11	PIN, CONNECTOR 13P	
* CN831	1-573-087-11	PIN, CONNECTOR 13P	
CN832	1-566-128-11	CONNECTOR, BOARD TO BOARD 10P	
△CN901	1-526-930-11	INLET, AC (~AC IN) (E, JE)	
△CN901	1-526-931-11	INLET, AC (~AC IN) (AEP, UK, G, IT, AUS, EA)	
* CN902	1-580-940-11	PIN, CONNECTOR 4P	
* CN903	1-580-940-11	PIN, CONNECTOR 4P (E, EA, JE)	
* CN904	1-569-502-11	PIN, CONNECTOR 7P	
CN905	1-573-826-11	CONNECTOR, BOARD TO BOARD 12P	
< DIODE >			
D551	8-719-987-63	DIODE 1N4148M	
D571	8-719-301-37	LED SEL2210S-CD (ON/STANDBY)	
D572	8-719-301-37	LED SEL2210S-CD (WAKE UP VOL SET)	
D573	8-719-301-37	LED SEL2210S-CD (MUTING) (AEP, UK, G, IT)	
D573	8-719-301-37	LED SEL2210S-CD (KARAOKE PON) (E, AUS, EA, JE)	
D574	8-719-301-37	LED SEL2210S-CD (PHONO)	
D575	8-719-301-37	LED SEL2210S-CD (TUNER)	
D576	8-719-301-37	LED SEL2210S-CD (CD)	
D577	8-719-301-37	LED SEL2210S-CD (DAT)	
D578	8-719-301-37	LED SEL2210S-CD (TAPE)	
D579	8-719-301-37	LED SEL2210S-CD (VIDEO)	
D591	8-719-987-63	DIODE 1N4148M	
D791	8-719-987-63	DIODE 1N4148M	
D800	8-719-987-63	DIODE 1N4148M	
D801	8-719-987-63	DIODE 1N4148M	
D851	8-719-987-63	DIODE 1N4148M	
D901	8-719-302-38	DIODE RBV-602-01	
D902	8-719-987-63	DIODE 1N4148M	
D903	8-719-987-63	DIODE 1N4148M	
D911	8-719-200-82	DIODE 11ES2	
D912	8-719-200-82	DIODE 11ES2	
D913	8-719-200-82	DIODE 11ES2	
D914	8-719-200-82	DIODE 11ES2	
D931	8-719-200-82	DIODE 11ES2	
D932	8-719-200-82	DIODE 11ES2	
D941	8-719-200-82	DIODE 11ES2	
D942	8-719-002-67	DIODE UZL-33H	
D943	8-719-987-63	DIODE 1N4148M	
D944	8-719-987-63	DIODE 1N4148M	
D951	8-719-200-82	DIODE 11ES2	
D952	8-719-934-22	DIODE HZS30-2L	
D953	8-719-933-33	DIODE HZS6A1L	
D961	8-719-987-63	DIODE 1N4148M	
D962	8-719-987-63	DIODE 1N4148M	

The components identified by
mark △ or dotted line with mark.
△ are critical for safety.
Replace only with part number
specified.

AC

PANEL

POWER

POWER AMPLIFIER

VOLUME

Ref. No.	Part No.	Description	Remark	Ref. No.	Part No.	Description	Remark
		< FLUORESCENT INDICATOR >					
FL501	1-519-720-11	INDICATOR TUBE, FLUORESCENT		R561	1-249-423-11	CARBON 3.3K 5%	1/4W
		< IC >		R562	1-249-413-11	CARBON 470 5%	1/4W
IC505	8-759-512-44	IC SN755703		R563	1-249-415-11	CARBON 680 5%	1/4W
IC506	8-759-512-44	IC SN755703		R564	1-249-417-11	CARBON 1K 5%	1/4W
IC507	8-759-636-56	IC M66311FP		R565	1-249-419-11	CARBON 1.5K 5%	1/4W
IC508	8-759-916-14	IC SN74HC04N					
IC591	8-759-820-62	IC LB1639		R566	1-249-421-11	CARBON 2.2K 5%	1/4W
		< JACK >		R571	1-249-411-11	CARBON 330 5%	1/4W
J601	1-562-837-21	JACK (HEADPHONES)		R572	1-249-411-11	CARBON 330 5%	1/4W
J611	1-562-837-21	JACK (MIX MIC) (E, AUS, EA, JE)		R573	1-249-411-11	CARBON 330 5%	1/4W
		< COIL >		R574	1-249-411-11	CARBON 330 5%	1/4W
* L801	1-420-872-00	COIL, AIR CORE					
* L851	1-420-872-00	COIL, AIR CORE		R581	1-249-417-11	CARBON 1K 5%	1/4W
		< LINE FILTER >		R582	1-249-417-11	CARBON 1K 5%	1/4W
△LF901	1-424-485-11	FILTER, LINE (G, IT)		R583	1-249-417-11	CARBON 1K 5%	1/4W
		< TRANSISTOR >		R584	1-249-417-11	CARBON 1K 5%	1/4W
Q611	8-729-620-05	TRANSISTOR 2SC2603-EF (E, AUS, EA, JE)		R585	1-249-417-11	CARBON 1K 5%	1/4W
Q612	8-729-620-05	TRANSISTOR 2SC2603-EF (E, AUS, EA, JE)					
Q621	8-729-620-05	TRANSISTOR 2SC2603-EF (E, AUS, EA, JE)		R586	1-249-417-11	CARBON 1K 5%	1/4W
Q701	8-729-119-76	TRANSISTOR 2SA1175-HFE		R587	1-249-417-11	CARBON 1K 5%	1/4W
Q781	8-729-620-05	TRANSISTOR 2SC2603-EF		R588	1-249-441-11	CARBON 100K 5%	1/4W
		< RESISTOR >		R589	1-249-417-11	CARBON 1K 5%	1/4W
Q792	8-729-620-05	TRANSISTOR 2SC2603-EF		R591	1-249-417-11	CARBON 1K 5%	1/4W
Q801	8-729-140-84	TRANSISTOR 2SC1841-PAFAEA					
Q851	8-729-140-84	TRANSISTOR 2SC1841-PAFAEA		R592	1-249-417-11	CARBON 1K 5%	1/4W
Q921	8-729-620-05	TRANSISTOR 2SC2603-EF		R593	1-249-414-11	CARBON 560 5%	1/4W
Q941	8-729-111-29	TRANSISTOR 2SD1616A-K		R594	1-249-431-11	CARBON 15K 5%	1/4W
		< RESISTOR >		R608	1-249-399-11	CARBON 33 5%	1/4W
Q942	8-729-620-05	TRANSISTOR 2SC2603-EF		R611	1-249-429-11	CARBON 10K 5%	1/4W
Q943	8-729-111-29	TRANSISTOR 2SD1616A-K					
Q951	8-729-118-01	TRANSISTOR 2SB1116		R612	1-249-417-11	CARBON 1K 5%	1/4W
Q961	8-729-111-29	TRANSISTOR 2SD1616A-K					
		< RESISTOR >		R613	1-249-417-11	CARBON 1K 5%	1/4W
R551	1-249-423-11	CARBON 3.3K 5%	1/4W				
R552	1-249-413-11	CARBON 470 5%	1/4W	R614	1-247-895-00	CARBON 470K 5%	1/4W
R553	1-249-415-11	CARBON 680 5%	1/4W				
R554	1-249-417-11	CARBON 1K 5%	1/4W	R615	1-249-425-11	CARBON 4.7K 5%	1/4W
R555	1-249-419-11	CARBON 1.5K 5%	1/4W				
		< RESISTOR >		R616	1-249-417-11	CARBON 1K 5%	1/4W
		< RESISTOR >					
		< RESISTOR >		R617	1-249-441-11	CARBON 100K 5%	1/4W
		< RESISTOR >					
		< RESISTOR >		R619	1-249-429-11	CARBON 10K 5%	1/4W
		< RESISTOR >		R621	1-247-899-11	CARBON 680K 5%	1/4W
		< RESISTOR >					
		< RESISTOR >		R622	1-249-421-11	CARBON 2.2K 5%	1/4W
		< RESISTOR >					
		< RESISTOR >		R623	1-249-405-11	CARBON 100 5%	1/4W
		< RESISTOR >					
		< RESISTOR >		R624	1-249-429-11	CARBON 10K 5%	1/4W
		< RESISTOR >					
		< RESISTOR >		R625	1-249-415-11	CARBON 680 5%	1/4W
		< RESISTOR >					
		< RESISTOR >		R658	1-249-399-11	CARBON 33 5%	1/4W
		< RESISTOR >		R701	1-249-433-11	CARBON 22K 5%	1/4W

The components identified by mark △ or dotted line with mark △ are critical for safety. Replace only with part number specified.

AC **PANEL** **POWER** **POWER AMPLIFIER** **VOLUME** **AUDIO**

Ref. No.	Part No.	Description	Remark
R702	1-249-441-11	CARBON	100K 5% 1/4W
R703	1-249-433-11	CARBON	22K 5% 1/4W
R704	1-249-433-11	CARBON	22K 5% 1/4W
R705	1-249-429-11	CARBON	10K 5% 1/4W
R706	1-249-436-11	CARBON	39K 5% 1/4W
R781	1-249-429-11	CARBON	10K 5% 1/4W
R782	1-249-405-11	CARBON	100 5% 1/4W
R793	1-249-441-11	CARBON	100K 5% 1/4W
R794	1-249-433-11	CARBON	22K 5% 1/4W
△R800	1-212-982-00	FUSIBLE	100 5% 1/2W F
R801	1-249-429-11	CARBON	10K 5% 1/4W
R802	1-249-437-11	CARBON	47K 5% 1/4W
R803	1-249-419-11	CARBON	1.5K 5% 1/4W
R804	1-249-437-11	CARBON	47K 5% 1/4W
R805	1-247-756-11	CARBON	2.2K 5% 1/2W
R806	1-247-756-11	CARBON	2.2K 5% 1/2W
△R807	1-212-881-11	FUSIBLE	100 5% 1/4W F
△R808	1-212-881-11	FUSIBLE	100 5% 1/4W F
△R809	1-217-151-00	RES, METAL PLATE	0.22 2W
R810	1-247-752-11	CARBON	1K 5% 1/2W
R811	1-247-752-11	CARBON	1K 5% 1/2W
△R812	1-212-958-00	FUSIBLE	10 5% 1/2W F
R813	1-249-417-11	CARBON	1K 5% 1/4W
R814	1-249-431-11	CARBON	15K 5% 1/4W
R815	1-249-441-11	CARBON	100K 5% 1/4W
R816	1-249-438-11	CARBON	56K 5% 1/4W
R817	1-249-425-11	CARBON	4.7K 5% 1/4W
R851	1-249-429-11	CARBON	10K 5% 1/4W
R852	1-249-437-11	CARBON	47K 5% 1/4W
R853	1-249-419-11	CARBON	1.5K 5% 1/4W
R854	1-249-437-11	CARBON	47K 5% 1/4W
R855	1-247-756-11	CARBON	2.2K 5% 1/2W
R856	1-247-756-11	CARBON	2.2K 5% 1/2W
△R859	1-217-151-00	RES, METAL PLATE	0.22 2W
△R862	1-212-958-00	FUSIBLE	10 5% 1/2W F
R863	1-249-417-11	CARBON	1K 5% 1/4W
R864	1-249-431-11	CARBON	15K 5% 1/4W
R865	1-249-441-11	CARBON	100K 5% 1/4W
R866	1-249-437-11	CARBON	47K 5% 1/4W
R867	1-249-425-11	CARBON	4.7K 5% 1/4W
△R876	1-212-881-11	FUSIBLE	100 5% 1/4W F
R902	1-249-429-11	CARBON	10K 5% 1/4W
△R911	1-219-134-11	FUSIBLE	0.1 5% 1/4W F
△R912	1-219-134-11	FUSIBLE	0.1 5% 1/4W F
R921	1-249-437-11	CARBON	47K 5% 1/4W
R922	1-249-405-11	CARBON	100 5% 1/4W
R923	1-249-429-11	CARBON	10K 5% 1/4W
R941	1-249-429-11	CARBON	10K 5% 1/4W
△R942	1-212-942-00	FUSIBLE	2.2 5% 1/2W F

Ref. No.	Part No.	Description	Remark
R943	1-249-417-11	CARBON	1K 5% 1/4W
R944	1-249-429-11	CARBON	10K 5% 1/4W
R945	1-249-441-11	CARBON	100K 5% 1/4W
R946	1-249-441-11	CARBON	100K 5% 1/4W
R947	1-249-417-11	CARBON	1K 5% 1/4W
R951	1-249-429-11	CARBON	10K 5% 1/4W
R952	1-249-425-11	CARBON	4.7K 5% 1/4W
R953	1-249-405-11	CARBON	100 5% 1/4W
R961	1-249-429-11	CARBON	10K 5% 1/4W
< VARIABLE RESISTOR >			
RV591	1-241-803-11	RES, VAR, CARBON (WITH MOTOR)	10K (VOLUME)
RV621	1-241-813-11	RES, VAR, CARBON	50K (MIC LEVEL) (E, AUS, EA, JE)
< RELAY >			
RY801	1-515-790-11	RELAY	
RY901	1-515-626-11	RELAY	
RY902	1-515-626-11	RELAY	
< SWITCH >			
S551	1-554-303-21	SWITCH, TACTILE	(SYSTEM POWER)
S552	1-554-303-21	SWITCH, TACTILE	(FUNCTION MAX >>)
S553	1-554-303-21	SWITCH, TACTILE	(FUNCTION < MIN)
S554	1-554-303-21	SWITCH, TACTILE	(WAKE UP VOL SET)
S555	1-554-303-21	SWITCH, TACTILE	(DISPLAY)
S561	1-554-303-21	SWITCH, TACTILE	(MUTING) (AEP, UK, G, IT)
S561	1-554-303-21	SWITCH, TACTILE	(KARAOKE PON) (E, AUS, EA, JE)
S562	1-554-303-21	SWITCH, TACTILE	(DIRECT)
S563	1-554-303-21	SWITCH, TACTILE	(MUSIC)
S564	1-554-303-21	SWITCH, TACTILE	(T. P. O.)
S565	1-554-303-21	SWITCH, TACTILE	(TOTAL EFFECT +)
S566	1-554-303-21	SWITCH, TACTILE	(TOTAL EFFECT -)
△S901	1-572-009-11	SELECTOR, VOLTAGE	(VOLTAGE SELECTOR) (E, EA, JE)

*	A-4347-374-A	AUDIO BOARD, COMPLETE	(AEP, UK)
*	A-4347-375-A	AUDIO BOARD, COMPLETE	(G, IT)
*	A-4347-376-A	AUDIO BOARD, COMPLETE	(E, AUS, EA, JE)

< CAPACITOR >			
C101	1-163-117-00	CERAMIC CHIP	100PF 5% 50V
C102	1-163-109-00	CERAMIC CHIP	47PF 5% 50V
C103	1-164-232-11	CERAMIC CHIP	0.01uF 50V
C111	1-164-346-11	CERAMIC CHIP	1uF 16V (E, AUS, EA, JE)
C112	1-164-182-11	CERAMIC CHIP	0.0033uF 10% 50V (E, AUS, EA, JE)

The components identified by mark △ or dotted line with mark △ are critical for safety. Replace only with part number specified.

AUDIO

Ref. No.	Part No.	Description	Remark	Ref. No.	Part No.	Description	Remark
C113	1-163-019-00	CERAMIC CHIP 0.0068uF 10%	50V	C253	1-124-907-11	ELECT 10uF 20%	50V
		(E, AUS, EA, JE)		C254	1-163-117-00	CERAMIC CHIP 100PF 5%	50V
C114	1-164-232-11	CERAMIC CHIP 0.01uF	50V	C255	1-163-117-00	CERAMIC CHIP 100PF 5%	50V
		(E, AUS, EA, JE)		C256	1-163-117-00	CERAMIC CHIP 100PF 5%	50V
C115	1-164-232-11	CERAMIC CHIP 0.01uF	50V	C257	1-164-346-11	CERAMIC CHIP 1uF	16V
		(E, AUS, EA, JE)		C258	1-164-346-11	CERAMIC CHIP 1uF	16V
C121	1-164-346-11	CERAMIC CHIP 1uF	16V			(E, AUS, EA, JE)	
C122	1-164-346-11	CERAMIC CHIP 1uF	16V	C261	1-164-489-11	CERAMIC CHIP 0.22uF 10%	16V
C123	1-164-232-11	CERAMIC CHIP 0.01uF	50V	C262	1-164-004-11	CERAMIC CHIP 0.1uF 10%	25V
C124	1-164-232-11	CERAMIC CHIP 0.01uF	50V	C263	1-163-809-11	CERAMIC CHIP 0.047uF 10%	25V
C141	1-126-157-11	ELECT 10uF 20%	16V	C264	1-163-024-00	CERAMIC CHIP 0.018uF 10%	50V
C151	1-163-117-00	CERAMIC CHIP 100PF 5%	50V	C265	1-163-019-00	CERAMIC CHIP 0.0068uF 10%	50V
C152	1-163-109-00	CERAMIC CHIP 47PF 5%	50V	C266	1-163-014-00	CERAMIC CHIP 0.0027uF 10%	50V
C153	1-164-232-11	CERAMIC CHIP 0.01uF	50V	C267	1-163-010-11	CERAMIC CHIP 0.0012uF 10%	50V
C161	1-164-346-11	CERAMIC CHIP 1uF	16V	C271	1-164-489-11	CERAMIC CHIP 0.22uF 10%	16V
		(E, AUS, EA, JE)		C272	1-164-343-11	CERAMIC CHIP 0.056uF 10%	25V
C162	1-164-182-11	CERAMIC CHIP 0.0033uF 10%	50V	C273	1-163-037-11	CERAMIC CHIP 0.022uF 10%	25V
		(E, AUS, EA, JE)		C274	1-164-232-11	CERAMIC CHIP 0.01uF	50V
C163	1-163-019-00	CERAMIC CHIP 0.0068uF 10%	50V	C275	1-163-016-00	CERAMIC CHIP 0.0039uF 10%	50V
		(E, AUS, EA, JE)		C276	1-163-011-11	CERAMIC CHIP 0.0015uF 10%	50V
C201	1-124-907-11	ELECT 10uF 20%	50V	C277	1-163-007-11	CERAMIC CHIP 680PF 10%	50V
C202	1-163-117-00	CERAMIC CHIP 100PF 5%	50V	C281	1-163-117-00	CERAMIC CHIP 100PF 5%	50V
C203	1-124-907-11	ELECT 10uF 20%	50V	C282	1-163-117-00	CERAMIC CHIP 100PF 5%	50V
C204	1-163-117-00	CERAMIC CHIP 100PF 5%	50V	C291	1-124-443-00	ELECT 100uF 20%	10V
C205	1-163-117-00	CERAMIC CHIP 100PF 5%	50V	C292	1-124-443-00	ELECT 100uF 20%	10V
C206	1-163-117-00	CERAMIC CHIP 100PF 5%	50V	C293	1-124-443-00	ELECT 100uF 20%	10V
C207	1-164-346-11	CERAMIC CHIP 1uF	16V	C294	1-124-443-00	ELECT 100uF 20%	10V
C208	1-164-346-11	CERAMIC CHIP 1uF	16V	C295	1-124-443-00	ELECT 100uF 20%	10V
		(E, AUS, EA, JE)		C301	1-136-165-00	FILM 0.1uF 5%	50V
C210	1-124-443-00	ELECT 100uF 20%	10V	C302	1-136-165-00	FILM 0.1uF 5%	50V
C211	1-164-489-11	CERAMIC CHIP 0.22uF 10%	16V	C304	1-124-903-11	ELECT 1uF 20%	50V
C212	1-164-004-11	CERAMIC CHIP 0.1uF 10%	25V	C305	1-163-117-00	CERAMIC CHIP 100PF 5%	50V
C213	1-163-809-11	CERAMIC CHIP 0.047uF 10%	25V	C307	1-124-443-00	ELECT 100uF 20%	10V
C214	1-163-024-00	CERAMIC CHIP 0.018uF 10%	50V	C310	1-164-232-11	CERAMIC CHIP 0.01uF	50V
C215	1-163-019-00	CERAMIC CHIP 0.0068uF 10%	50V	C311	1-164-232-11	CERAMIC CHIP 0.01uF	50V
C216	1-163-014-00	CERAMIC CHIP 0.0027uF 10%	50V	C331	1-124-463-00	ELECT 0.1uF 20%	50V
C217	1-163-010-11	CERAMIC CHIP 0.0012uF 10%	50V	C340	1-124-907-11	ELECT 10uF 20%	50V
C221	1-164-489-11	CERAMIC CHIP 0.22uF 10%	16V	C351	1-136-165-00	FILM 0.1uF 5%	50V
C222	1-164-343-11	CERAMIC CHIP 0.056uF 10%	25V	C352	1-136-165-00	FILM 0.1uF 5%	50V
C223	1-163-037-11	CERAMIC CHIP 0.022uF 10%	25V	C354	1-124-903-11	ELECT 1uF 20%	50V
C224	1-164-232-11	CERAMIC CHIP 0.01uF	50V	C355	1-163-117-00	CERAMIC CHIP 100PF 5%	50V
C225	1-163-016-00	CERAMIC CHIP 0.0039uF 10%	50V	C357	1-124-443-00	ELECT 100uF 20%	10V
C226	1-163-011-11	CERAMIC CHIP 0.0015uF 10%	50V	C360	1-164-232-11	CERAMIC CHIP 0.01uF	50V
C227	1-163-007-11	CERAMIC CHIP 680PF 10%	50V	C361	1-164-232-11	CERAMIC CHIP 0.01uF	50V
C231	1-163-117-00	CERAMIC CHIP 100PF 5%	50V	C390	1-124-907-11	ELECT 10uF 20%	50V
C232	1-163-117-00	CERAMIC CHIP 100PF 5%	50V	C501	1-124-443-00	ELECT 100uF 20%	10V
C233	1-124-443-00	ELECT 100uF 20%	10V	C502	1-164-004-11	CERAMIC CHIP 0.1uF 10%	25V
C234	1-164-232-11	CERAMIC CHIP 0.01uF	50V	C503	1-164-004-11	CERAMIC CHIP 0.1uF 10%	25V
C251	1-124-907-11	ELECT 10uF 20%	50V	C504	1-164-004-11	CERAMIC CHIP 0.1uF 10%	25V
C252	1-163-117-00	CERAMIC CHIP 100PF 5%	50V				

AUDIO

Ref. No.	Part No.	Description	Remark
C505	1-164-004-11	CERAMIC CHIP 0.1uF 10%	25V
C506	1-164-232-11	CERAMIC CHIP 0.01uF	50V
C511	1-163-009-11	CERAMIC CHIP 0.001uF 10%	50V
C512	1-124-443-00	ELECT 100uF 20%	10V
C513	1-124-443-00	ELECT 100uF 20%	10V
C514	1-164-232-11	CERAMIC CHIP 0.01uF	50V
C515	1-164-232-11	CERAMIC CHIP 0.01uF	50V
C521	1-164-004-11	CERAMIC CHIP 0.1uF 10%	25V
C522	1-164-004-11	CERAMIC CHIP 0.1uF 10%	25V
C523	1-163-009-11	CERAMIC CHIP 0.001uF 10%	50V
C524	1-163-009-11	CERAMIC CHIP 0.001uF 10%	50V
C525	1-164-004-11	CERAMIC CHIP 0.1uF 10%	25V
C526	1-164-004-11	CERAMIC CHIP 0.1uF 10%	25V
C531	1-163-125-00	CERAMIC CHIP 220PF 5%	50V
C541	1-124-443-00	ELECT 100uF 20%	10V
C542	1-163-009-11	CERAMIC CHIP 0.001uF 10%	50V
C543	1-164-004-11	CERAMIC CHIP 0.1uF 10%	25V
C601	1-124-907-11	ELECT 10uF 20%	50V
C602	1-124-443-00	ELECT 100uF 20%	10V
C603	1-163-117-00	CERAMIC CHIP 100PF 5%	50V
C604	1-126-926-11	ELECT 1000uF 20%	10V
C605	1-163-117-00	CERAMIC CHIP 100PF 5%	50V
C607	1-163-117-00	CERAMIC CHIP 100PF 5%	50V
C651	1-124-907-11	ELECT 10uF 20%	50V
C652	1-124-443-00	ELECT 100uF 20%	10V
C653	1-163-117-00	CERAMIC CHIP 100PF 5%	50V
C654	1-126-926-11	ELECT 1000uF 20%	10V
C655	1-163-117-00	CERAMIC CHIP 100PF 5%	50V
C657	1-163-117-00	CERAMIC CHIP 100PF 5%	50V
< CONNECTOR >			
CN201	1-566-128-11	CONNECTOR, BOARD TO BOARD 10P	
CN202	1-568-437-11	SOCKET, CONNECTOR 7P	
CN203	1-568-443-11	SOCKET, CONNECTOR 13P	
CN204	1-573-826-11	CONNECTOR, BOARD TO BOARD 12P	
CN205	1-573-826-11	CONNECTOR, BOARD TO BOARD 12P	
< DIODE >			
D231	8-719-801-78	DIODE 1SS184	
D291	8-719-801-78	DIODE 1SS184	
D292	8-719-801-78	DIODE 1SS184	
D341	8-719-801-78	DIODE 1SS184	
D342	8-719-801-78	DIODE 1SS184	
D501	8-719-801-78	DIODE 1SS184	
D502	8-719-801-78	DIODE 1SS184	
D503	8-719-801-78	DIODE 1SS184	
D504	8-719-801-78	DIODE 1SS184	
D511	8-719-801-78	DIODE 1SS184	
D512	8-719-801-78	DIODE 1SS184	

Ref. No.	Part No.	Description	Remark
D541	8-719-801-78	DIODE 1SS184	
D601	8-719-801-78	DIODE 1SS184	
< IC >			
IC101	8-759-636-55	IC M5218AFP	
IC102	8-759-516-43	IC CD4053BCM (E, AUS, EA, JE)	
IC103	8-759-516-39	IC CD4051BCM	
IC201	8-759-636-57	IC CXA1492Q	
IC301	8-759-636-55	IC M5218AFP	
IC302	8-759-516-43	IC CD4053BCM	
IC303	8-759-516-41	IC CD4052BCM	
IC501	8-759-074-78	IC uPD78134GF-051-3B9	
IC502	8-759-500-31	IC X24C01P	
IC503	8-759-516-41	IC CD4052BCM	
IC504	8-759-991-11	IC XR1091DCP	
IC601	8-759-636-55	IC M5218AFP	
< JUMPER RESISTOR >			
JR1	1-216-296-00	METAL CHIP 0 5%	1/8W
JR2	1-216-296-00	METAL CHIP 0 5%	1/8W
JR3	1-216-295-00	METAL CHIP 0 5%	1/10W
JR4	1-216-295-00	METAL CHIP 0 5%	1/10W
JR5	1-216-296-00	METAL CHIP 0 5%	1/8W
JR6	1-216-296-00	METAL CHIP 0 5%	1/8W
JR7	1-216-296-00	METAL CHIP 0 5%	1/8W
JR8	1-216-296-00	METAL CHIP 0 5%	1/8W
JR501	1-216-295-00	METAL CHIP 0 5%	1/10W
JR503	1-216-295-00	METAL CHIP 0 5%	1/10W (AEP, UK, G, IT)
JR504	1-216-295-00	METAL CHIP 0 5%	1/10W (E, AUS, EA, JE)
< TRANSISTOR >			
Q231	8-729-620-06	TRANSISTOR 2SC3052-EF	
Q232	8-729-620-06	TRANSISTOR 2SC3052-EF	
Q291	8-729-620-06	TRANSISTOR 2SC3052-EF	
Q292	8-729-600-22	TRANSISTOR 2SA1235-F	
Q311	8-729-620-06	TRANSISTOR 2SC3052-EF	
Q341	8-729-620-06	TRANSISTOR 2SC3052-EF	
Q342	8-729-620-06	TRANSISTOR 2SC3052-EF	
Q361	8-729-620-06	TRANSISTOR 2SC3052-EF	
Q391	8-729-620-06	TRANSISTOR 2SC3052-EF	
Q501	8-729-620-06	TRANSISTOR 2SC3052-EF	
Q502	8-729-805-67	TRANSISTOR 2SA1342	
Q504	8-729-805-67	TRANSISTOR 2SA1342	
Q506	8-729-805-43	TRANSISTOR 2SC3396	
Q507	8-729-805-40	TRANSISTOR 2SC3900	
Q601	8-729-620-06	TRANSISTOR 2SC3052-EF	

AUDIO

Ref. No.	Part No.	Description	Remark	Ref. No.	Part No.	Description	Remark
Q651	8-729-620-06	TRANSISTOR 2SC3052-EF		R217	1-216-121-00	METAL CHIP	1M 5% 1/10W
		< RESISTOR >		R231	1-216-073-00	METAL CHIP	10K 5% 1/10W
R101	1-216-089-00	METAL CHIP 47K 5%	1/10W	R232	1-216-093-00	METAL CHIP	68K 5% 1/10W
R102	1-216-085-00	METAL CHIP 33K 5%	1/10W	R233	1-216-049-00	METAL CHIP	1K 5% 1/10W
R111	1-216-121-00	METAL CHIP 1M 5%	1/10W	R234	1-216-097-00	METAL CHIP	100K 5% 1/10W
		(E, AUS, EA, JE)		R235	1-216-049-00	METAL CHIP	1K 5% 1/10W
R112	1-216-073-00	METAL CHIP 10K 5%	1/10W	R236	1-216-049-00	METAL CHIP	1K 5% 1/10W
		(E, AUS, EA, JE)		R237	1-216-049-00	METAL CHIP	1K 5% 1/10W
R113	1-216-089-00	METAL CHIP 47K 5%	1/10W	R238	1-216-049-00	METAL CHIP	1K 5% 1/10W
		(E, AUS, EA, JE)		R240	1-216-295-00	METAL CHIP	0 5% 1/10W
R114	1-216-089-00	METAL CHIP 47K 5%	1/10W	R251	1-216-069-00	METAL CHIP	6.8K 5% 1/10W
R121	1-216-121-00	METAL CHIP 1M 5%	1/10W	R252	1-216-073-00	METAL CHIP	10K 5% 1/10W
R122	1-216-121-00	METAL CHIP 1M 5%	1/10W			(E, AUS, EA, JE)	
R130	1-216-065-00	METAL CHIP 4.7K 5%	1/10W	R253	1-216-073-00	METAL CHIP	10K 5% 1/10W
R131	1-216-089-00	METAL CHIP 47K 5%	1/10W	R254	1-216-049-00	METAL CHIP	1K 5% 1/10W
R132	1-216-085-00	METAL CHIP 33K 5%	1/10W	R255	1-216-073-00	METAL CHIP	10K 5% 1/10W
R133	1-216-081-00	METAL CHIP 22K 5%	1/10W	R256	1-216-073-00	METAL CHIP	10K 5% 1/10W
R134	1-216-077-00	METAL CHIP 15K 5%	1/10W	R261	1-216-121-00	METAL CHIP	1M 5% 1/10W
R135	1-216-073-00	METAL CHIP 10K 5%	1/10W	R262	1-216-121-00	METAL CHIP	1M 5% 1/10W
R136	1-216-071-00	METAL CHIP 8.2K 5%	1/10W	R263	1-216-121-00	METAL CHIP	1M 5% 1/10W
R137	1-216-069-00	METAL CHIP 6.8K 5%	1/10W	R264	1-216-121-00	METAL CHIP	1M 5% 1/10W
R138	1-216-061-00	METAL CHIP 3.3K 5%	1/10W	R265	1-216-121-00	METAL CHIP	1M 5% 1/10W
R141	1-216-049-00	METAL CHIP 1K 5%	1/10W	R266	1-216-121-00	METAL CHIP	1M 5% 1/10W
R151	1-216-089-00	METAL CHIP 47K 5%	1/10W	R267	1-216-121-00	METAL CHIP	1M 5% 1/10W
R152	1-216-085-00	METAL CHIP 33K 5%	1/10W	R281	1-216-073-00	METAL CHIP	10K 5% 1/10W
R161	1-216-121-00	METAL CHIP 1M 5%	1/10W	R282	1-216-093-00	METAL CHIP	68K 5% 1/10W
		(E, AUS, EA, JE)		R283	1-216-049-00	METAL CHIP	1K 5% 1/10W
R162	1-216-073-00	METAL CHIP 10K 5%	1/10W	R291	1-216-049-00	METAL CHIP	1K 5% 1/10W
		(E, AUS, EA, JE)		R292	1-216-049-00	METAL CHIP	1K 5% 1/10W
R163	1-216-089-00	METAL CHIP 47K 5%	1/10W	R301	1-216-057-00	METAL CHIP	2.2K 5% 1/10W
		(E, AUS, EA, JE)		R302	1-216-109-00	METAL CHIP	330K 5% 1/10W
R164	1-216-089-00	METAL CHIP 47K 5%	1/10W	R303	1-216-295-00	METAL CHIP	0 5% 1/10W
R201	1-216-069-00	METAL CHIP 6.8K 5%	1/10W	R304	1-216-079-00	METAL CHIP	18K 5% 1/10W
R202	1-216-073-00	METAL CHIP 10K 5%	1/10W	R308	1-216-105-00	METAL CHIP	220K 5% 1/10W
		(E, AUS, EA, JE)		R309	1-216-085-00	METAL CHIP	33K 5% 1/10W
R203	1-216-073-00	METAL CHIP 10K 5%	1/10W	R312	1-216-095-00	METAL CHIP	82K 5% 1/10W
R204	1-216-049-00	METAL CHIP 1K 5%	1/10W	R313	1-216-105-00	METAL CHIP	220K 5% 1/10W
R205	1-216-073-00	METAL CHIP 10K 5%	1/10W	R315	1-216-121-00	METAL CHIP	1M 5% 1/10W
R206	1-216-073-00	METAL CHIP 10K 5%	1/10W	R316	1-216-097-00	METAL CHIP	100K 5% 1/10W
R207	1-216-049-00	METAL CHIP 1K 5%	1/10W	R331	1-216-097-00	METAL CHIP	100K 5% 1/10W
R208	1-216-049-00	METAL CHIP 1K 5%	1/10W	R341	1-216-121-00	METAL CHIP	1M 5% 1/10W
R209	1-216-049-00	METAL CHIP 1K 5%	1/10W	R342	1-216-049-00	METAL CHIP	1K 5% 1/10W
R210	1-216-049-00	METAL CHIP 1K 5%	1/10W	R343	1-216-049-00	METAL CHIP	1K 5% 1/10W
R211	1-216-121-00	METAL CHIP 1M 5%	1/10W	R344	1-216-097-00	METAL CHIP	100K 5% 1/10W
R212	1-216-121-00	METAL CHIP 1M 5%	1/10W	R345	1-216-073-00	METAL CHIP	10K 5% 1/10W
R213	1-216-121-00	METAL CHIP 1M 5%	1/10W	R351	1-216-057-00	METAL CHIP	2.2K 5% 1/10W
R214	1-216-121-00	METAL CHIP 1M 5%	1/10W	R352	1-216-109-00	METAL CHIP	330K 5% 1/10W
R215	1-216-121-00	METAL CHIP 1M 5%	1/10W	R353	1-216-295-00	METAL CHIP	0 5% 1/10W
R216	1-216-121-00	METAL CHIP 1M 5%	1/10W	R354	1-216-079-00	METAL CHIP	18K 5% 1/10W

AUDIO	BRIDGE	CONNECTOR (A)	CONNECTOR (B)	JACK	SPEAKER
TRANSFORMER (A)		TRANSFORMER (B)		TRANSFORMER (C)	

Ref. No.	Part No.	Description	Remark		
R358	1-216-105-00	METAL CHIP	220K	5%	1/10W
R359	1-216-085-00	METAL CHIP	33K	5%	1/10W
R362	1-216-095-00	METAL CHIP	82K	5%	1/10W
R363	1-216-105-00	METAL CHIP	220K	5%	1/10W
R365	1-216-121-00	METAL CHIP	1M	5%	1/10W
R366	1-216-097-00	METAL CHIP	100K	5%	1/10W
R391	1-216-121-00	METAL CHIP	1M	5%	1/10W
R392	1-216-049-00	METAL CHIP	1K	5%	1/10W
R393	1-216-049-00	METAL CHIP	1K	5%	1/10W
R501	1-216-121-00	METAL CHIP	1M	5%	1/10W
R502	1-216-073-00	METAL CHIP	10K	5%	1/10W
R503	1-216-073-00	METAL CHIP	10K	5%	1/10W
R504	1-216-049-00	METAL CHIP	1K	5%	1/10W
R505	1-216-073-00	METAL CHIP	10K	5%	1/10W
R506	1-216-089-00	METAL CHIP	47K	5%	1/10W
R507	1-216-089-00	METAL CHIP	47K	5%	1/10W
R508	1-216-073-00	METAL CHIP	10K	5%	1/10W
R509	1-216-089-00	METAL CHIP	47K	5%	1/10W
R510	1-216-049-00	METAL CHIP	1K	5%	1/10W
R511	1-216-053-00	METAL CHIP	1.5K	5%	1/10W
R512	1-216-049-00	METAL CHIP	1K	5%	1/10W
R513	1-216-009-00	METAL CHIP	22	5%	1/10W
R514	1-216-009-00	METAL CHIP	22	5%	1/10W
R521	1-216-049-00	METAL CHIP	1K	5%	1/10W
R522	1-216-049-00	METAL CHIP	1K	5%	1/10W
R523	1-216-049-00	METAL CHIP	1K	5%	1/10W
R524	1-216-049-00	METAL CHIP	1K	5%	1/10W
R525	1-216-049-00	METAL CHIP	1K	5%	1/10W
R526	1-216-049-00	METAL CHIP	1K	5%	1/10W
R527	1-216-049-00	METAL CHIP	1K	5%	1/10W
R531	1-216-049-00	METAL CHIP	1K	5%	1/10W
R532	1-216-049-00	METAL CHIP	1K	5%	1/10W
R533	1-216-049-00	METAL CHIP	1K	5%	1/10W
R534	1-216-049-00	METAL CHIP	1K	5%	1/10W
R535	1-216-049-00	METAL CHIP	1K	5%	1/10W
R536	1-216-049-00	METAL CHIP	1K	5%	1/10W
R537	1-216-049-00	METAL CHIP	1K	5%	1/10W
R538	1-216-049-00	METAL CHIP	1K	5%	1/10W
R541	1-216-057-00	METAL CHIP	2.2K	5%	1/10W
R542	1-216-097-00	METAL CHIP	100K	5%	1/10W
R543	1-216-049-00	METAL CHIP	1K	5%	1/10W
R601	1-216-075-00	METAL CHIP	12K	5%	1/10W
R602	1-216-057-00	METAL CHIP	2.2K	5%	1/10W
R603	1-216-075-00	METAL CHIP	12K	5%	1/10W
R604	1-216-017-00	METAL CHIP	47	5%	1/10W
R605	1-216-049-00	METAL CHIP	1K	5%	1/10W
R606	1-216-049-00	METAL CHIP	1K	5%	1/10W
R607	1-216-121-00	METAL CHIP	1M	5%	1/10W
R608	1-216-097-00	METAL CHIP	100K	5%	1/10W

Ref. No.	Part No.	Description	Remark		
R651	1-216-075-00	METAL CHIP	12K	5%	1/10W
R652	1-216-057-00	METAL CHIP	2.2K	5%	1/10W
R653	1-216-075-00	METAL CHIP	12K	5%	1/10W
R654	1-216-017-00	METAL CHIP	47	5%	1/10W
R655	1-216-049-00	METAL CHIP	1K	5%	1/10W
R656	1-216-049-00	METAL CHIP	1K	5%	1/10W
R657	1-216-121-00	METAL CHIP	1M	5%	1/10W
R658	1-216-097-00	METAL CHIP	100K	5%	1/10W
< VIBRATOR >					
X501	1-577-364-11	VIBRATOR, CERAMIC (12MHz)			

*	1-642-438-11	BRIDGE BOARD	*****		
*	1-642-439-11	CONNECTOR (A) BOARD	*****		
*	1-642-440-11	CONNECTOR (B) BOARD	*****		
*	1-642-436-11	JACK BOARD	*****		
*	1-644-352-11	SPEAKER BOARD	*****		
*	1-642-441-11	TRANSFORMER (A) BOARD	*****		
*	1-642-442-11	TRANSFORMER (B) BOARD	*****		
*	1-642-443-11	TRANSFORMER (C) BOARD	*****		
< CAPACITOR >					
C401	1-162-282-31	CERAMIC	100PF	10%	50V
C451	1-162-282-31	CERAMIC	100PF	10%	50V
C895	1-164-159-11	CERAMIC	0.1uF		50V (G, IT)
C896	1-164-159-11	CERAMIC	0.1uF		50V (G, IT)
< CONNECTOR >					
CN101	1-563-311-11	CONNECTOR, BOARD TO BOARD	10P		
CN102	1-573-826-11	CONNECTOR, BOARD TO BOARD	12P		
* CN311	1-573-844-31	CONNECTOR, BOARD TO BOARD	12P		
* CN312	1-573-844-31	CONNECTOR, BOARD TO BOARD	12P		
* CN401	1-573-844-11	CONNECTOR, BOARD TO BOARD	12P		
* CN402	1-573-844-11	CONNECTOR, BOARD TO BOARD	12P		
* CN403	1-573-844-11	CONNECTOR, BOARD TO BOARD	12P		
CN404	1-568-860-11	SOCKET, CONNECTOR	17P		
* CN405	1-568-850-11	SOCKET, CONNECTOR	7P		
* CN411	1-580-739-11	SOCKET, CONNECTOR	15P (SYSTEM CONTROL 1)		
* CN412	1-580-740-11	SOCKET, CONNECTOR	17P (SYSTEM CONTROL 2)		
CN703	1-563-311-11	CONNECTOR, BOARD TO BOARD	10P		
CN821	1-573-094-11	SOCKET, CONNECTOR	13P		
CN822	1-573-094-11	SOCKET, CONNECTOR	13P		
* CN911	1-580-939-11	SOCKET, CONNECTOR	4P		

BRIDGE
CONNECTOR (A)
CONNECTOR (B)
JACK
SPEAKER

TRANSFORMER (A)
TRANSFORMER (B)
TRANSFORMER (C)

Ref. No.	Part No.	Description	Remark
* CN912	1-580-939-11	SOCKET, CONNECTOR 4P (E, EA, JE)	
CN913	1-569-493-11	SOCKET, CONNECTOR 7P	
* CN914	1-569-502-11	PIN, CONNECTOR 7P	
CN921	1-569-496-11	SOCKET, CONNECTOR 10P	
* CN922	1-569-502-11	PIN, CONNECTOR 7P	
CN931	1-569-493-11	SOCKET, CONNECTOR 7P	
CN932	1-569-493-11	SOCKET, CONNECTOR 7P	

< JACK >

J401	1-565-304-11	JACK, PIN 4P (ADAPTOR) (E, AUS, EA, JE)
J402	1-569-662-11	JACK, PIN 1P (SUPER WOOFER OUT)
J701	1-568-572-11	JACK, PIN 2P (SURROUND SPEAKER) (UK, E, AUS, EA, JE)

< RESISTOR >

R401	1-249-417-11	CARBON	1K	5%	1/4W
R451	1-249-417-11	CARBON	1K	5%	1/4W
R895	1-247-727-11	CARBON	10	5%	1/2W (G, IT)
R896	1-247-727-11	CARBON	10	5%	1/2W (G, IT)

< TERMINAL >

TB701	1-537-276-21	TERMINAL BOARD (SPEAKER)
-------	--------------	--------------------------

MISCELLANEOUS

7	1-690-994-11	WIRE (FLAT TYPE) (17 CORE)
25	1-690-993-11	WIRE (FLAT TYPE) (13 CORE)
27	1-690-992-11	WIRE (FLAT TYPE) (7 CORE)
31	1-590-240-11	WIRE, FLAT TYPE (7 CORE)
33	1-535-706-11	PLUG, JUMPER (E, AUS, EA, JE)
△F901	1-532-285-00	FUSE, TIME-LAG (T1. 25A)
△F902	1-532-286-00	FUSE, TIME-LAG (T2. 5A) (E, EA, JE)
△PT901	1-450-896-11	TRANSFORMER, POWER (AEP, G, IT)
△PT901	1-450-897-11	TRANSFORMER, POWER (UK, AUS)
△PT901	1-450-898-11	TRANSFORMER, POWER (E, EA, JE)

HARDWARE LIST

#1	7-682-547-04	SCREW +BVTT	3X6	(S)
#2	7-685-647-79	SCREW +BVTP	3X10	TYPE2 N-S
#3	7-685-645-79	SCREW +BVTP	3X6	TYPE2 IT-3
#4	7-682-547-09	SCREW +BVTT	3X6	(S)
#5	7-685-650-79	SCREW +BVTP	3X16	TYPE2 IT-3

The components identified by
 mark △ or dotted line with mark.
 △ are critical for safety.
 Replace only with part number
 specified.

TA-H2700

SONY[®] SERVICE MANUAL

AEP Model
UK Model
E Model
Australian Model
Tourist Model

SUPPLEMENT-1

File this supplement with the service manual.

Subject: Add the TAISAKU Board

* This TAISAKU Board correspond to TRANSFORMER (C)
BOARD that is showed on the Service Manual.

1. PRINTED WIRING BOARD—TAISAKU SECTION—

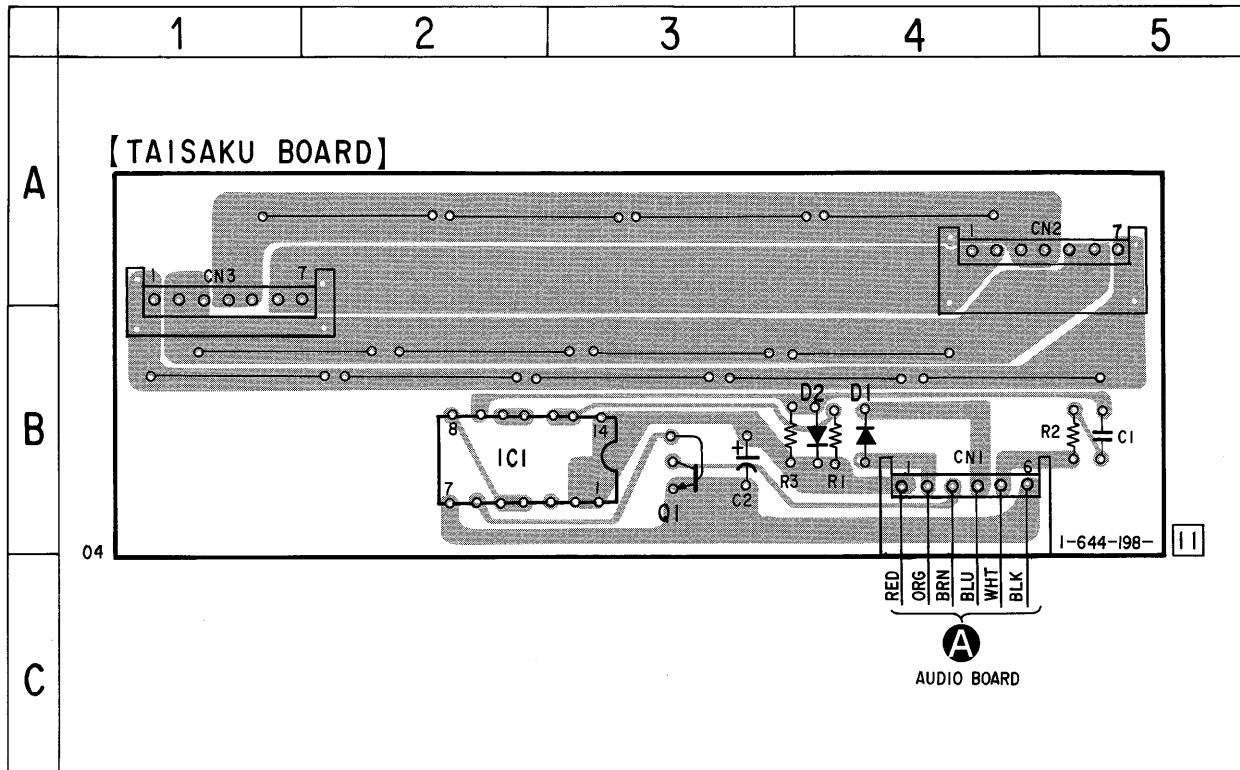

2. SCHEMATIC DIAGRAM—TAISAKU SECTION—

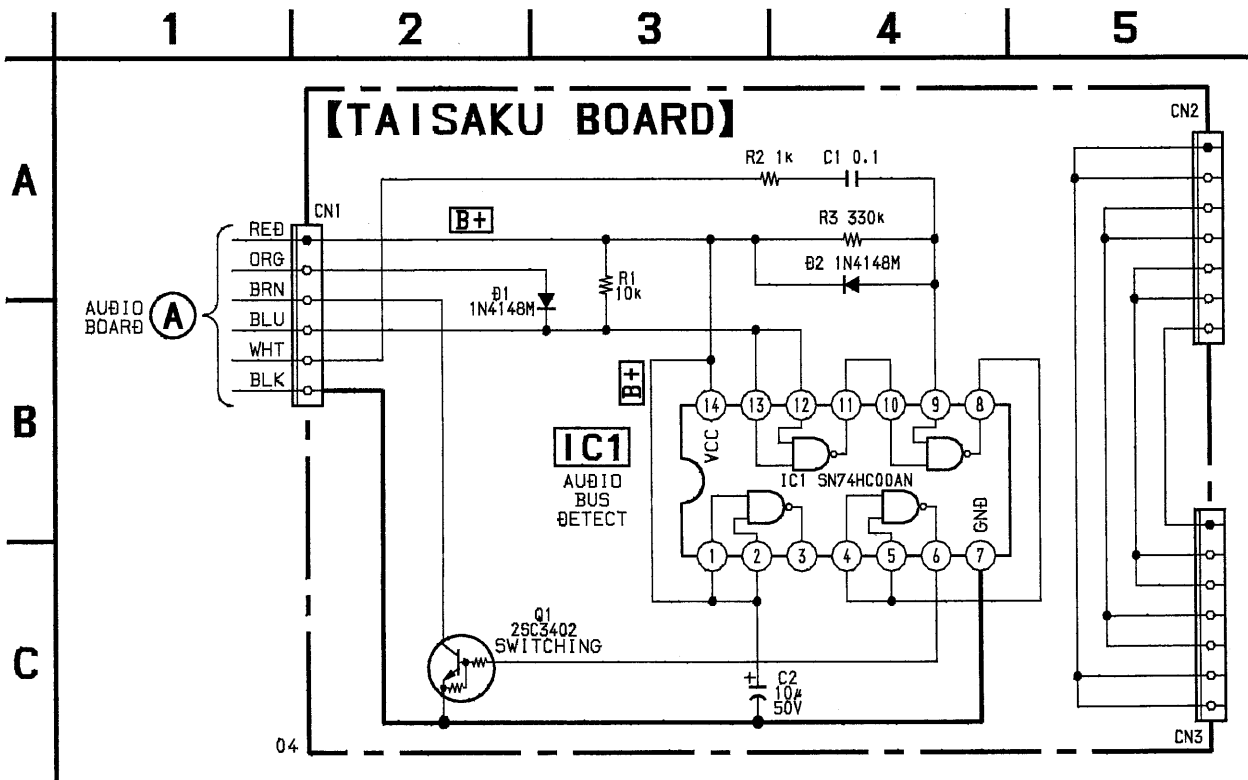

3. SEMICONDUCTOR LEAD LAYOUTS

SN74HC00AN

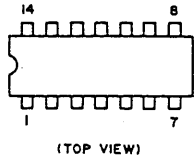

DTC114ES



1N4148M

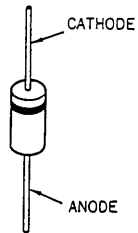

Note on Printed Wiring Board :

- : parts extracted from the component side.
- : parts extracted from the conductor side.
- ▨ : Pattern on the side which is seen.

Note on Schematic Diagram :

- All capacitors are in μF unless otherwise noted. pF : μF 50WV or less are not indicated except for electrolytics and tantalums.
- All resistors are in Ω and 1/4 W or less unless otherwise specified.
- ⓑ+ : B+ Line

4. PRINTED WIRING BOARD—AUDIO SECTION—

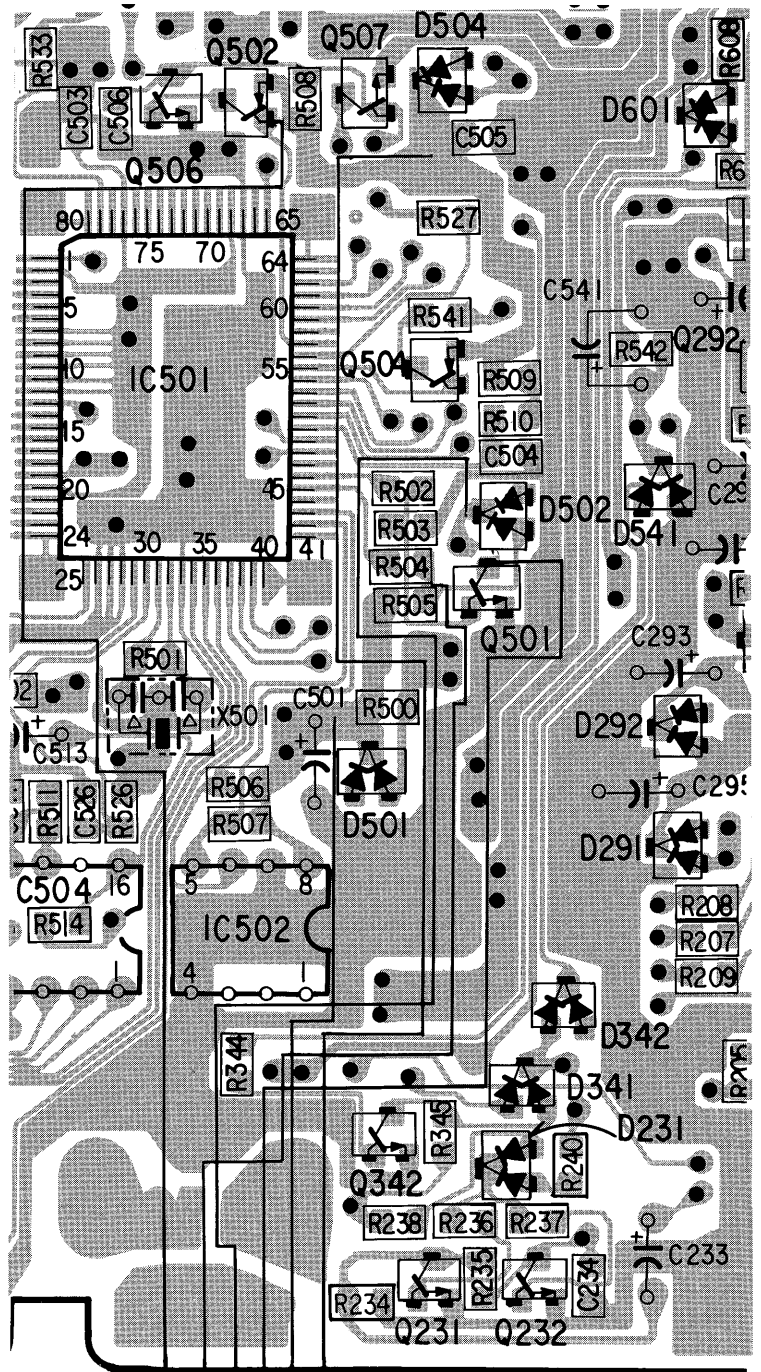

A
TAISAKU
BOARD
CNI

5. SCHEMATIC DIAGRAM—AUDIO SECTION—

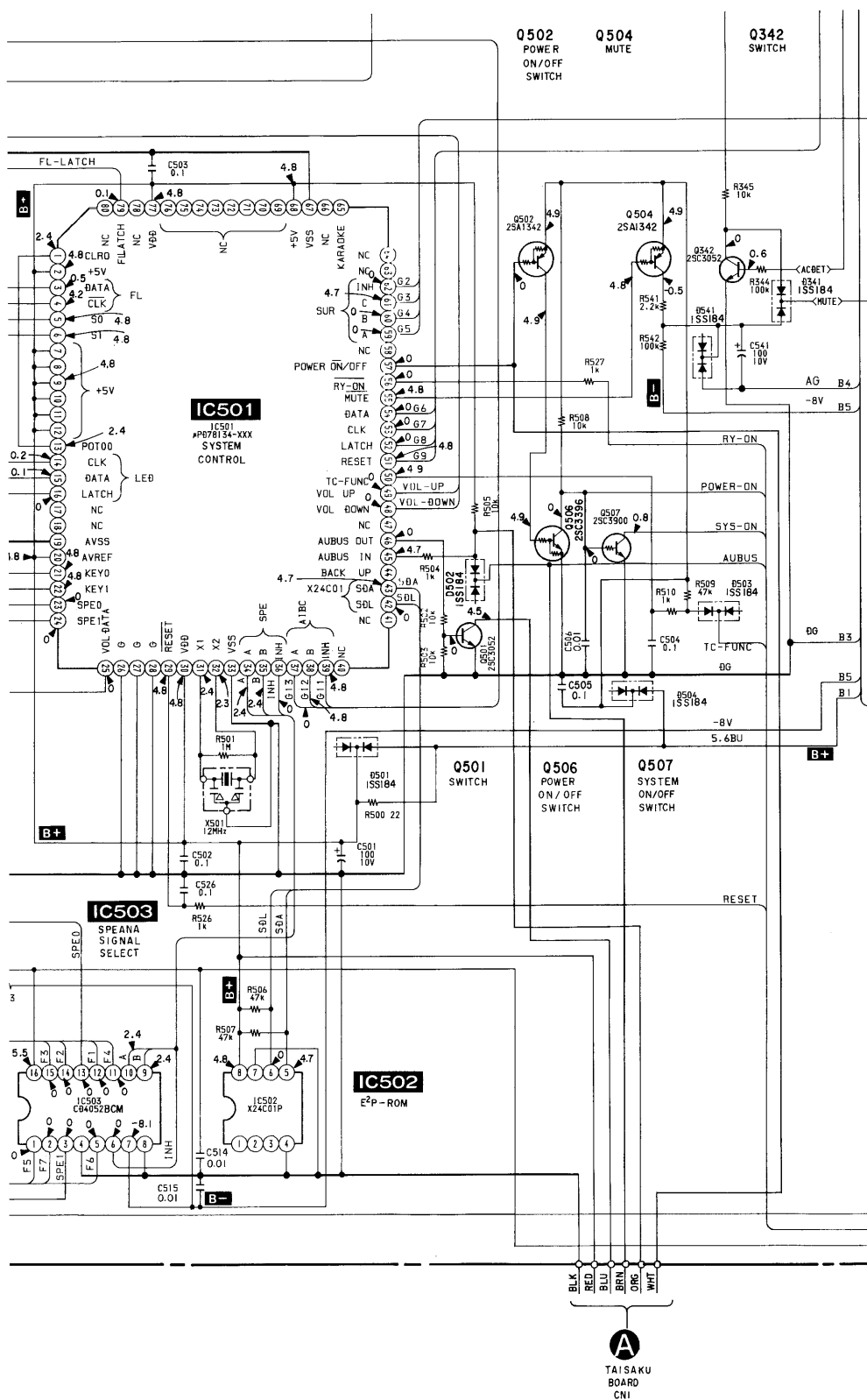

6. ELECTRICAL PARTS LIST

NOTE:

- Due to standardization, replacements in the parts list may be different from the parts specified in the diagrams or the components used on the set.
- -XX and -X mean standardized parts, so they may have some difference from the original one.
- RESISTORS
All resistors are in ohms.
METAL: Metal-film resistor.
METAL OXIDE: Metal oxide-film resistor.
F: nonflammable

- Items marked "*" are not stocked since they are seldom required for routine service. Some delay should be anticipated when ordering these items.
- SEMICONDUCTORS
In each case, u: μ , for example:
uA.: μ A.. uPA.: μ PA..
uPB.: μ PB.. uPC.: μ PC.. uPD.: μ PD..
- CAPACITORS
uF: μ F
- COILS
uH: μ H

When indicating parts by reference number, please include the board.

Ref.No.	Part No.	Description	Remark
	A-4347-934-A	MOUNTED PCB, TAISAKU *****	
		< CAPACITOR >	
C1	1-136-165-00	FILM 0.1uF	5% 50V
C2	1-124-907-11	ELECT 10uF	20% 50V
		< CONNECTOR >	
CN1	1-564-521-11	PIN, CONNECTOR 6P	
CN2	1-569-493-11	SOCKET, CONNECTOR 7P	
CN3	1-569-493-11	SOCKET, CONNECTOR 7P	
		< DIODE >	
D1	8-719-987-63	DIODE 1N4148M	
D2	8-719-987-63	DIODE 1N4148M	
		< IC >	
IC1	8-759-916-12	IC SN74HCO0AN	
		< TRANSISTOR >	
Q1	8-729-900-80	TRANSISTOR DTC114ES	
		< RESISTOR >	
R1	1-249-429-11	CARBON 10K 5%	1/4W
R2	1-249-417-11	CARBON 1K 5%	1/4W
R3	1-247-891-00	CARBON 330K 5%	1/4W

TA-H2700

9-957-113-81

Sony Corporation
Consumer A & V Products Company
Home A & V Products Div.

—6—

English
94G0478-1
Printed in Japan
© 1994. 7

Published by Home A & V Products Div.
Quality Engineering Dept.