

# KIT 74. PC PARALLEL PORT RELAY BOARD

With the rapid progress in computer technology many people now have a surplus computer just gathering dust somewhere. Thus these computers are free to be used as dedicated controllers for a variety of uses: turning on/off lights or other devices around the home, office, laboratory or factory come to mind. All that is needed is the interface to connect it to the real world.

This Kit provides both the hardware and the software to do this. The hardware PCB plugs in directly to the parallel port of the computer. It carries 8 relays. Each relay is switched on or off by one bit of the output byte which usually goes to your printer to print a character. The relays **RWH-SH-112D** from [Goodsky](http://www.goodsky.com). They are rated to switch 250VAC at 12A. However, because of the PCB track thickness and width we do not recommend using the relay to switch more than 5A. If you want to switch more current then we suggest you solder some heavy duty wire links, on the bottom of the PCB, from the relay contacts to the screw terminal block (effectively in parallel with the PCB track).

You can download the relay data sheet from [http://www.kitsrus.com/pdf/rwh\\_relay.pdf](http://www.kitsrus.com/pdf/rwh_relay.pdf)

The terminals blocks are rated 300V / 10A.

## HARDWARE

The PCB contains eight identical switched relay positions, power input positions to the relays (either 2.5mm jack centre positive, or via the terminal block) and a DB25 connector to the parallel port of a PC. To keep the kit simple no input latches have been put on it. If your application is important then you should use a UPS to keep the computer operating in the case of a mains power supply failure. If the board is accidentally disconnected from the parallel port then the 10K pulldown resistors will turn the relay off. The diodes protect the transistors from the back-emf which occurs when the relay is turned off and its magnetic field collapses.

Solder the resistors into place first. Make sure to get the right ones in the right place. The components for the first relay position are given in the Components listing. Add the relays last.

The relays are under direct control of the output byte (8 bits) from the parallel port. When a pin is high a nominal 5V is presented to the base resistor R1. Since there is a fixed 0.6V drop across the BE junction of Q1 there is 4.4V across R1 (5V - 0.6V). So by Ohms law 1.33 mA flows through the 3K3 resistor. There is also 0.6V across the 10K pulldown resistor which draws 0.06mA. If we assume a hFE of 100 for Q1 then 127mA flows through the CE leads of Q1 when it is turned on ( $I_C = I_B \cdot h_{FE}$ ). Since the 12V relay turns on at around 30mA this current is more than enough to turn on the relay. The relay has a coil resistance of around 400 ohms and a coil power consumption of 30mW.

Note that this analysis assumes 5V is available from the parallel port pin. In more modern computers this may not be so. If the LED turns on but the relay does not then you will know that the transistor is not saturating. Reduce the value of R1 (and all the similar resistors) to 2K7 from 3K3 will probably fix this. Measure the voltage on the collector. When the relay is on then the voltage should be around 0.1V. If it is 3V - 4V then the transistor is not fully on.

## SOFTWARE

Download the software from our website and unzip <http://kitsrus.com/zip/k74disk.zip>

**DOS Utilities.** The **k74\_dos.txt** file give full details on how to use these DOS files in batch files. Of course, you can write your own programs in any language to output a byte to the printer port and the bits which are high will turn on the corresponding relay. The overlay on the PCB shows which bit in the output byte turns that particular relay on. For example, output 00010001, or 11 in hex turns on relays 1 & 5. Each relay number is also marked on the overlay for easy reference.

**Windows 9x/2000/NT.** After you run setup read the **drivers.txt** file and follow the instructions. Put an icon on your desktop of the **diy74.exe**. Play with the program and you will soon learn how it works. Time files can be saved. Read the Help file for more information.

**Linux software** for Kit 74 has been written by James Cameron. You may get it at Quozl's Open Source Work.

<http://quozl.netrek.org/>

## COMPONENTS

Resistors 5%, carbon, 1/4W:			
1K brown black red	R3 6 9 12 15 18 21 24		8
10K brown black orange	R2 5 8 11 14 17 20 23		8
3K3 orange orange red red	R1 4 7 10 13 16 19 22		8
1N4004 diode	D1 2 3 4 5 6 7 8 9		9
5mm red LED	L1 2 3 4 5 6 7 8		8
2 pole terminal block			1
3 pole terminal block	X1 2 3 4 5 6 7 8		8
100uF/25V ecap			1
BC547 transistor	Q1 2 3 4 5 6 7 8		8
12V relay RWH-SH-112D			8
Power jack 2.5mm			1
D25 Right angle, male connector			1
Kit 74V2 pcb			1

See our website for all our kits. If you like Kit 74 also look at kits 108 and 93.

<http://www.kitsrus.com/>

-----

# KIT 74. PC PARALLEL PORT RELAY BOARD

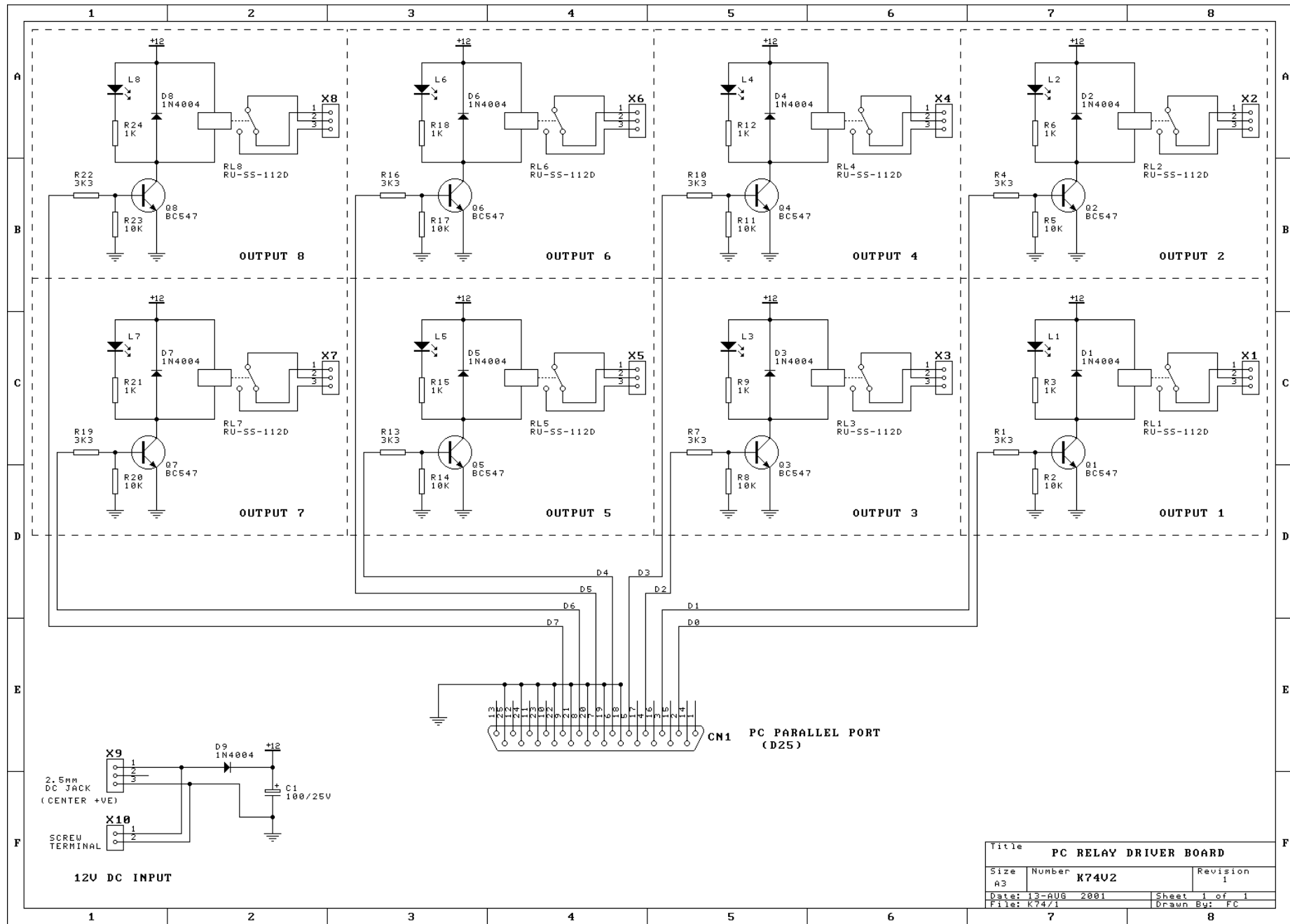

Title		PC RELAY DRIVER BOARD	
Size	Number	Revision	
A3	K74U2	1	
Date:	13-AUG 2001	Sheet	1 of 1
File:	K74/1	Drawn By:	FC