

CDP-H3700

SERVICE MANUAL

*AEP Model
UK Model
E Model
Australian Model
Tourist Model*

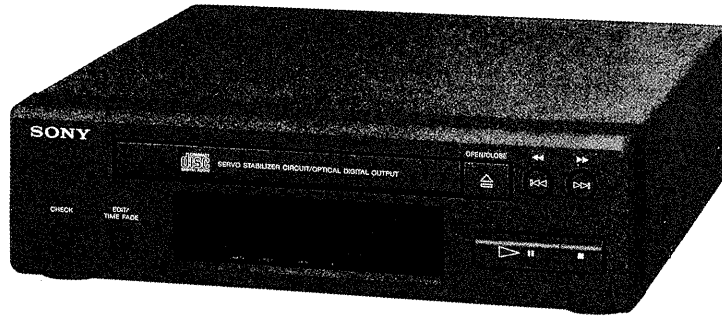

This set is the CD player section
in FH-E757, MHC-2700/3700.

Model Name Using Similar Mechanism	CDP-H3600
CD Mechanism Type	CDM13BA-5BD3
Optical Pick-Up Block Type	BU-5BD3

SPECIFICATIONS

System	Compact disc digital audio system
Laser	Semiconductor laser ($\lambda = 780 \text{ nm}$) Emission duration: continuous
Laser output	Max. $44.6 \mu\text{W}$ * * This output is the value measured at a distance of about 200 mm from the objective lens surface on the Optical Pick-up Block.
Signal to noise ratio	More than 90 dB
Dynamic range	More than 90 dB
Harmonic distortion	Less than 0.05% (at 1 kHz)
Channel separation	More than 90 dB
Output level	2 V (at 50 kilohms)
Load impedance	More than 10 kilohms
Outputs	DIGITAL OUT OPTICAL (optical output connector): wave length 660 nm, output level -18 dBm

Design and specifications subject to change
without notice.

For the United Kingdom and European
countries.

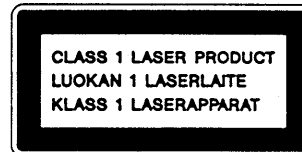

This appliance is classified as a CLASS 1
LASER product. The CLASS 1 LASER
PRODUCT label is located on the rear
exterior.

SAFETY-RELATED COMPONENT WARNING!!

COMPONENTS IDENTIFIED BY MARK \triangle OR DOTTED
LINE WITH MARK \triangle ON THE SCHEMATIC DIAGRAMS
AND IN THE PARTS LIST ARE CRITICAL TO SAFE
OPERATION. REPLACE THESE COMPONENTS WITH
SONY PARTS WHOSE PART NUMBERS APPEAR AS
SHOWN IN THIS MANUAL OR IN SUPPLEMENTS PUBLISHED BY SONY.



COMPACT DISC PLAYER
SONY[®]

TABLE OF CONTENTS

<u>Section</u>	<u>Title</u>	<u>Page</u>
1. GENERAL		
1-1.	Parts Identification	3
2. TEST MODES		
2-1.	Test Mode of Display Microcomputer (IC401)	4
2-2.	Test Mode of CD System Controller (IC202)	4
3. ELECTRICAL BLOCK CHECKING		5
4. DIAGRAMS		
4-1.	Pin Description	7
4-2.	Block Diagram	9
4-3.	Printed Wiring Boards	12
4-4.	Schematic Diagram	15
4-5.	Semiconductor Lead Layouts	22
5. EXPLODED VIEWS		
5-1.	Chassis	23
5-2.	CD Block (CDM13BA-5BD3)	24
5-3.	Optical Pick-Up Block (BU-5BD3)	25
6. ELECTRICAL PARTS LIST		26

MODEL IDENTIFICATION

—BACK PANEL—

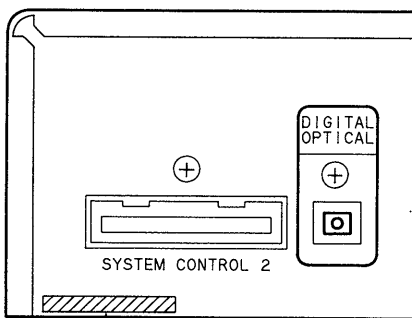

4-948-753-11 (AE): AEP, UK, AUS model
 4-948-753-32 (E) : E, TR model

- AUS: Australian model
- TR : Tourist model

NOTES ON HANDLING THE OPTICAL PICK-UP BLOCK OR BASE UNIT

The laser diode in the optical pick-up block may suffer electrostatic breakdown because of the potential difference generated by the charged electrostatic load, etc. on clothing and the human body.

During repair, pay attention to electrostatic breakdown and also use the procedure in the printed matter which is included in the repair parts.

The flexible board is easily damaged and should be handled with care.

NOTES ON LASER DIODE EMISSION CHECK

The laser beam on this model is concentrated so as to be focused on the disc reflective surface by the objective lens in the optical pick-up block. Therefore, when checking the laser diode emission, observe from more than 30cm away from the objective lens.

LASER DIODE AND FOCUS SEARCH OPERATION CHECK

1. Make POWER switch on with no disc inserted and disc table closed.
2. Confirm that the following operation is performed while observing the objective lens.

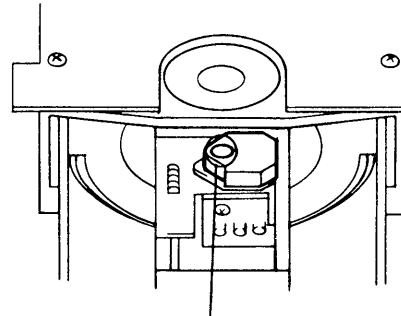



- Confirm that laser beam is spread.
- Up and down motion of the objective lens. (3 times)

SECTION 1 GENERAL

This section is extracted from
instruction manual.

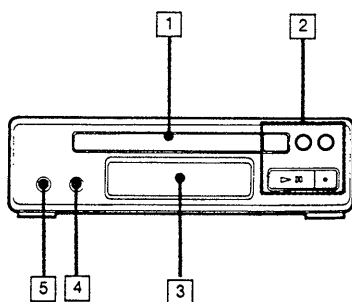
1-1. PARTS IDENTIFICATION



- 1 Disc tray
- 2 CD operation buttons
 - △ : OPEN/CLOSE
 - ▷|| : Play/pause
 - : Stop
 - ◀◀ ◀◀ ▷▷ ▷▷ : Manual search (when kept depressed)/Automatic Music Sensor (when pressed)
- 3 Display window
- 4 EDIT/TIME FADE button  
- 5 CHECK button

SECTION 2 TEST MODES



2-1. Test Mode of Display Microcomputer (IC401)

Connect Pin ⑩ of IC401 to ground and turn ON the POWER switch, thus you can test the following 3 tests.

(1) All FL tube ON

This mode is actuated immediately after turning ON the POWER switch.

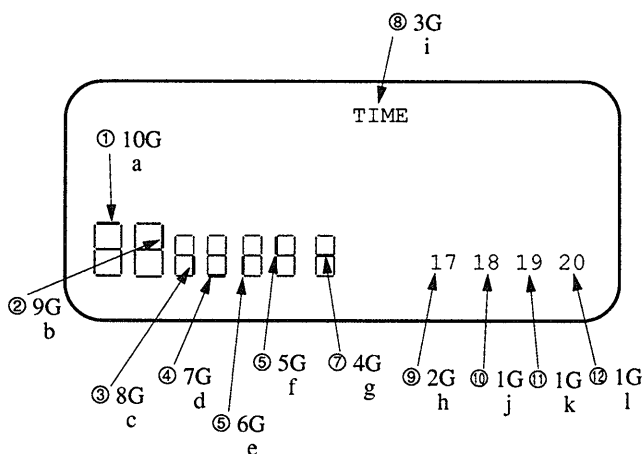

(2) FL tube segment check

This mode is actuated by pressing the  key in the state of (1). Every time the  key is pressed, the segments are indicated sequentially from the segment a. When the last l segment is displayed, keying in is no longer accepted while continuing the lighting-up state of the last segment. Conditions are normal provided all lamps light up in the following order.



(3) KEY check

This mode is effected by pressing the  key in the state of (1), while indicating "1." Every time a new key is pressed subsequently, the indicated number is incremented. Conditions are normal provided "7" is indicated when all types of keys are pressed. Even if a key is pressed again, it is not counted.

* To leave the mode (2) or (3), press the  and  keys in duplication, thereby the mode returning to all ON mode.

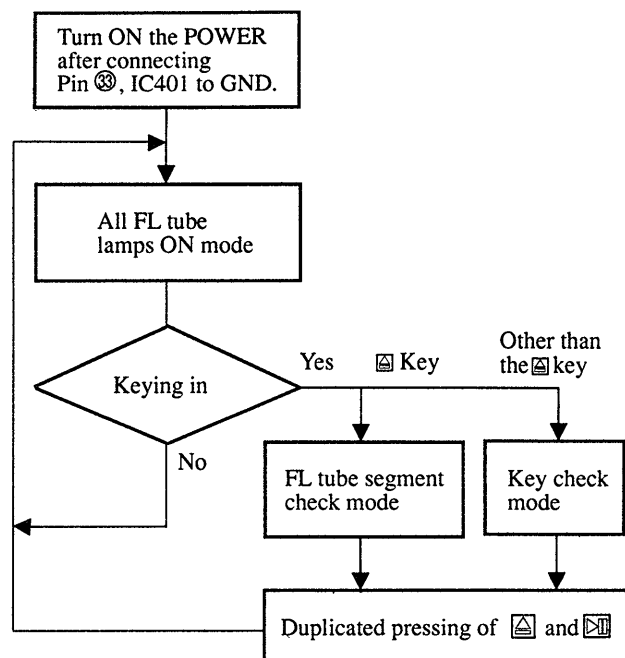

2-2. Test Modes of CD System Controller (IC202)

(1) ADJUST mode

When this mode is effected, the machine is operated normally except for the following.

- When pin ⑩, IC201 (ADJ) is set to "L" after turning ON the POWER switch:
 1. GFS is no longer monitored during PLAY, PAUSE or SEARCH, while not stopping even with GFS remaining still at "L" (NG).
 2. No high-speed feeding is activated during SEARCH.
 3. Focus gain is reset to normal gain during PLAY (normally, the gain is lowered to reduce noise when FOCUS is locked).
- When Pin ⑩, IC201 (AFADJ) is set to "L" after turning ON the POWER switch:
 1. Regardless of Pin ⑩ (ADJ) of the CLV-S fixed function, the CLV mode during PLAY becomes CLV-S (rough servo) only while Pin e remains "L".

(2) AFADJUST mode

In this mode, it is possible to check the interface between the display micron (IC401) and CD syscon (IC201).

- Set Pin ⑩, IC201 (AFADJ) to "L" before turning ON the POWER switch.
 1. Every time the  key is pressed after turning On the POWER switch, indication on the FL tube is switched correspondingly. Conditions are normal provided the indication repeats the 4 patterns including all lamp ON.

SECTION 3 ELECTRICAL BLOCK CHECKING

Note :

1. CD Block basically constructed to operate without adjustment. Therefore, check each item in order given.
2. Use YEDS-18 disc (3-702-101-01) unless otherwise indicated.
3. Use the oscilloscope with more than $10M\Omega$ impedance.
4. Clean an object lens by an applicator with neutral detergent when the signal level is low than specified value with the following checks.

S Curve Check

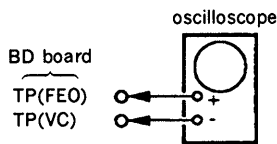

Procedure :

1. Connect oscilloscope to test point TP (FEO) on BD board.
2. Connect between test point TP (FES) and TP (VC) by lead wire.
3. Turned Power switch on and actuate the focus serch. (actuate the focus serch when disc table is moving in and out.)
4. Check the oscilloscope waveform (S curve) is symmetrical between A and B. And confirm peak to peak level within $3 \pm 1V_{p-p}$.

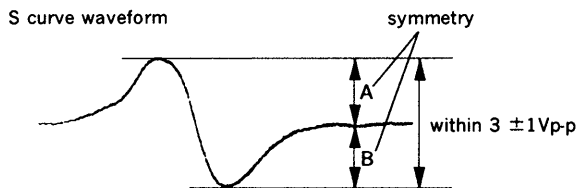

5. After check, remove the lead wire connected in step 2.
- Note :**
- Try to measure several times to make sure that the ratio of A : B or B : A is more than 10 : 7.
 - Take sweep time as long as possible and light up the brightness to obtain best waveform.

RF Level Check

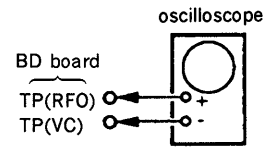

Procedure :

1. Connect oscilloscope to test point TP (RFO) on BD board.
2. Turn Power switch on.
3. Put disc (YEDS-18) in and playback.
4. Confirm that oscilloscope waveform is clear and check RF signal level is correct or not.

Note :

Clear RF signal waveform means that the shape "◇" can be clearly distinguished at the center of the waveform.

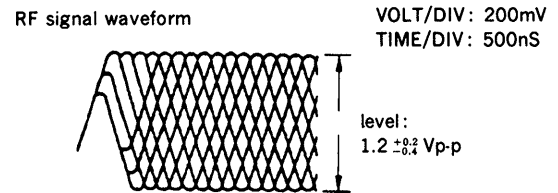

E-F Balance Check

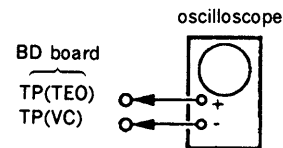

Procedure :

1. Connect test point TP (ADJ) to ground and TP (TES) to TP (VC) with lead wire.
2. Connect oscilloscope to test point TP (TEO) on BD board.
3. Turn Power switch on.
4. Put disc (YEDS-18) in and playback.
5. Confirm that the oscilloscope waveform is symmetrical on the top and bottom in relation to 0V, and check this level.

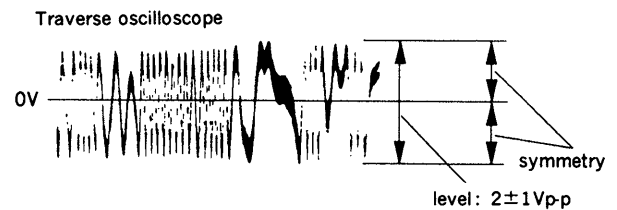

6. Remove the lead wire connected in step 1.

RF PLL Free-run Frequency Check

Procedure :

1. Connect frequency counter to test point (PCK) with lead wire.

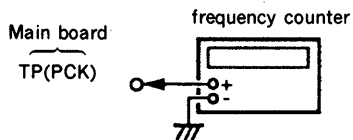

2. Turn Power switch on.
3. Confirm that reading on frequency counter is 4.3218MHz.

Focus/Tracking Gain

This gain has a margin, so even if it is slightly off.

There is no problem.

Therefore, do not perform, this adjustment.

Please note that it should be fixed to mechanical center position when you moved and do not know original position.

Checking Location :

[BD Board]

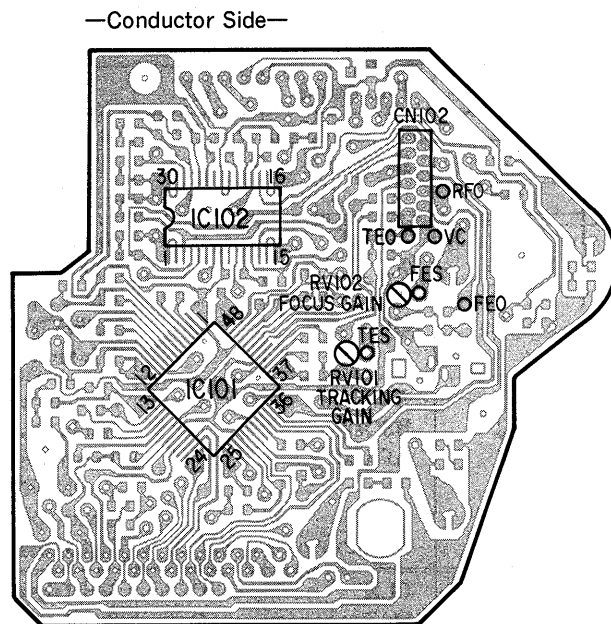

[MAIN Board] —Component Side—

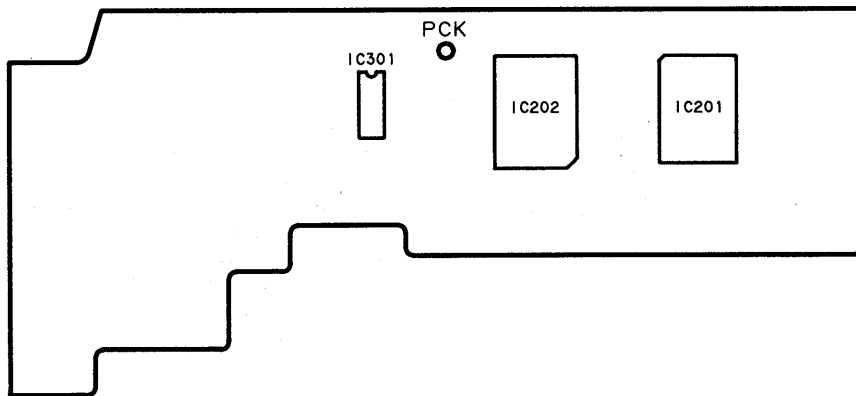

[MAIN Board] —Conductor Side—

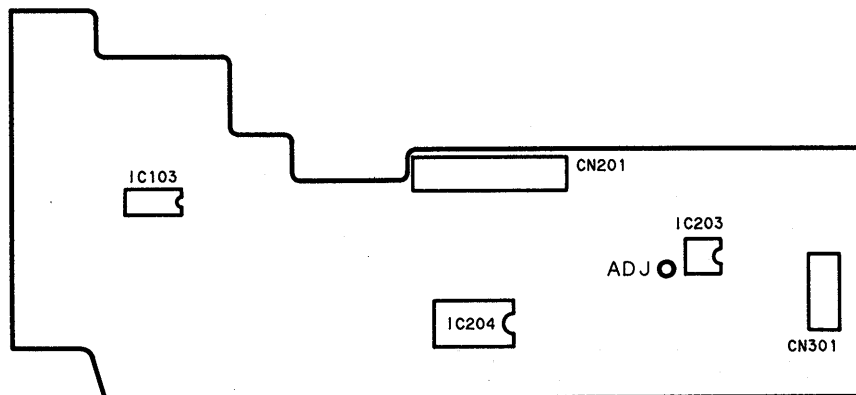

SECTION 4 DIAGRAMS

4-1. PIN DESCRIPTION

• IC201 CD System Controller (μ PD75116GF-F21-3BE)

Functions effected by the captioned controller include IC101 (RF signal processing, servo), IC202 (DSP, digital filter) and loading control in the CD unit, data exchange with IC401 (display controller), audio bus entry, etc.

Pin No.	Pin Name	I/O	Description
1-2	G MUTE, GCLR	O	Not in use with the model (open).
3	DPCLK	O	Display data transfer clock output to IC401 (display micon)
4-6		O	IC204 (CXD2554M) control output.
7	$\overline{\text{RESET}}$	I	System reset input. "L": Reset
8	X2	I	Clock input
9	X1	I	Clock input (4 MHz)
10	DFCT SW	O	DEFECT circuit ON/OFF switching output of IC101 (CXA1372Q). It is turned OFF ("H") to focus-search the DISC flaw detection circuit.
11	AMUTE	O	Muting control output. "H": Mute
12	BSOUT	O	Audio bus output
13	AFADJ	I	Test mode input. Various test operations are effected upon "L" after turning ON the POWER.
14	LDON	O	Optical pickup laser diode ON/OFF switching output. "H": ON
15	XLT	O	Serial data latch output to IC202 (CXD2500AQ)
16	CLK	O	Serial data transfer clock output to IC202 (CXD2500AQ)
17	DATA	O	Serial data output to IC202 (CXD2500AQ)
18	MODE	I	Not in use with the model (GND)
19	ADJ	I	Test mode input. Upon "L," GFS checking is disabled while continuously rotating the spindle no matter whether frame synch is issued during PLAY, PAUSE or SEARCH.
20	GFS	I	GFS signal input from IC202 (CXD2500AQ). "L": NG "H": OK
21	FOK	I	Focus OK signal input from IC101 (CXA1372Q). "H": OK
22 - 23		O	Not in use with the model (open)
24	LODOUT	O	Output to rotate M291 (loading motor) in the loading out direction. *1
25	LODIN	O	Output to rotate M291 (loading motor) in the loading in direction. *1
26	V _{ss}	-	Power terminal (GND)
27	$\overline{\text{IN SW}}$	I	S292 (Loading in switch) input
28	$\overline{\text{OUT SW}}$	I	S291 (Loading out switch) input
29	KEY REQ	I	Key data request input from IC401 (display controller)
30	BS IN	I	Audio bus input
31 - 36			Not in use with the model (GND)
37	SENS	I	SENS input from IC101 (CXA1372Q) and IC202 (CXD2500AQ)
38	TIMER	I	Not in use with the model (pull up)
39	D/F 16BIT	I	IC202 (CXD2500AQ) digital filter mode setting input. It is fixed at 16 bit, 4fs with the model (pull up).
40		I	Not in use with the model (GND)
41	SUBQ	I	Subcode Q data input from IC202 (CXD2500AQ)
42		O	Not in use with the model (open)
43	SQCLK	O	Subcode Q data readout clock output to IC202 (CXD2500AQ)
44	SCOR	I	Subcode sync S0 + S1 detection input from IC202 (CXD2500AQ)
45 - 56		O	Not in use with the model (open)
57	N.C.	I	Not in use with the model (+5V)
58	V _{DD}	-	Power terminal (+5V)
59 - 62	DPDATA3-0	I/O	Key data input and display data output with IC401 (display controller)
63 - 64		O	Not in use with the model (open)

*1 Loading motor control

	IN	OUT	BRAKE
LODOUT ②	L	H	H
LODIN ②	H	L	H

• IC401 Display controller (μ PD75206GF-716-3BE)

In charge of displaying the FL tube and keying in, it exchanges data with the IC201 (CD system controller) in 4-bit parallel mode.

Pin No.	Pin Name	I/O	Description
1	RESET	I	System reset input. "L": Reset
2 - 11	G1-10	O	Digital output to the FL tube
12 - 15		O	Not in use with the model (open)
16, 17	l, k	O	FL tube segment output
18	VLOAD	-	Power supply for the FL tube controller (builtin) (-32V)
19	VPRE	-	Power supply for the FL tube predriver (-3.5V)
20 - 25	j ~ e	O	FL tube segment output
26	VDD	-	Power terminal (+5V)
27, 28	d, c	O	FL tube segment output
29, 30	b, a	O	FL tube segment, key scan output
31, 32		I	Not in use with the model (GND)
33	TEST	I	Test mode input. "L": Test mode
34	SELECT	I	Not in use with the model (pull up)
35	BSIN	I	Not in use with the model (pull up)
36	DPCLK	I	Display data transfer clock input from IC201 (CD system controller)
37, 38		I	Not in use with the model (pull up)
39		O	Not in use with the model (pull up)
40, 41		O	Not in use with the model (open)
42	KEY REQ	O	Key data request output to IC201 (CD system controller)
43 - 46	DPDATA0-3	I/O	Key data output and display data input with IC201 (CD system controller)
47 - 50	KEY0-3	I	Key data input
51, 52		I	Not in use with the model (pull up)
53, 54		I	Not in use with the model (GND)
55		O	Not in use with the model (open)
56	X1	I	System clock input (4.19 MHz)
57	X2	I	System clock input
58	Vss	-	Power supply terminal (GND)
59		I	Not in use with the model (GND)
60 - 64		O	Not in use with the model (open)

4-2. BLOCK DIAGRAM

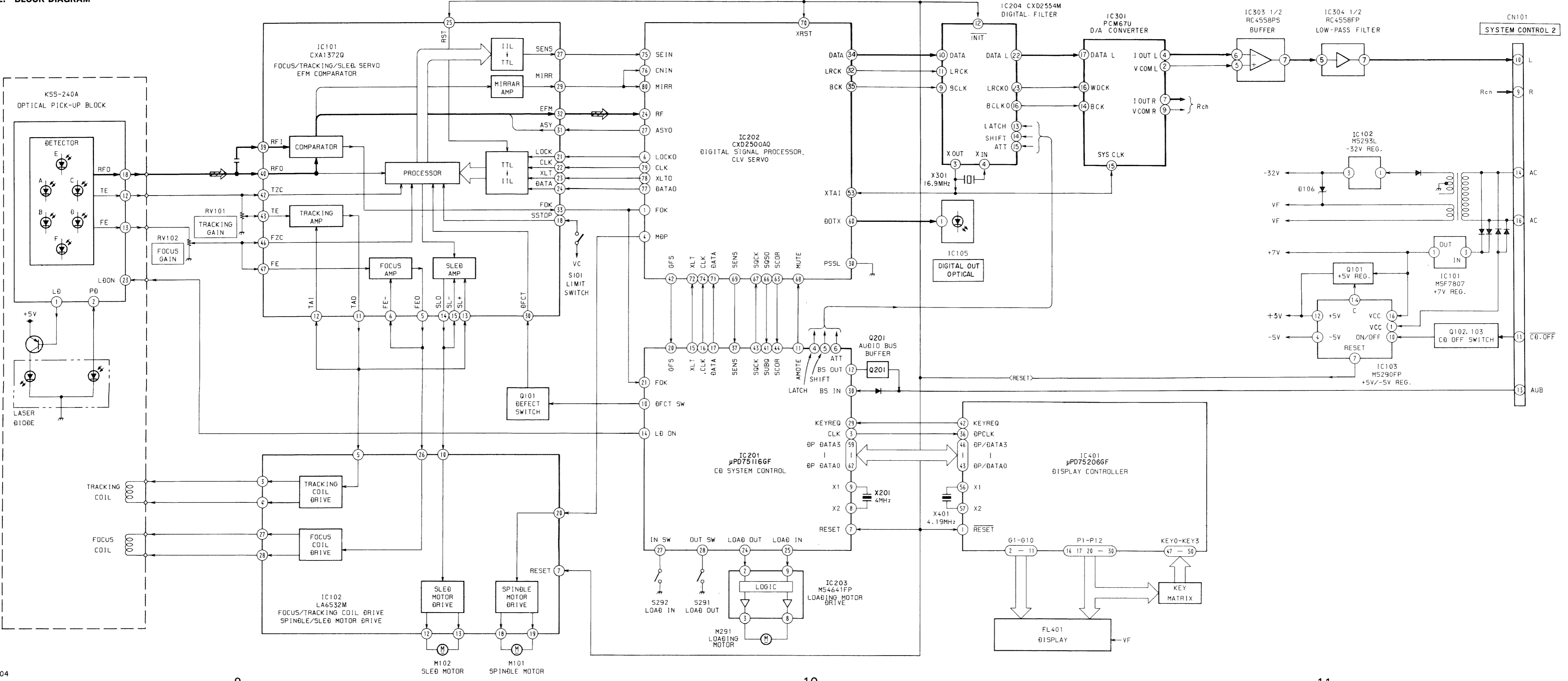

● Semiconductor Location
Except BD Board

Ref. No.	Location
D101	C-7
D102	C-6
D103	C-7
D104	D-9
D106	C-8
D113	C-2
D131	C-5
D132	C-2
D201	H-5
D206	H-6
D401	E-15
D402	E-18
D403	E-14
IC101	D-6
IC102	C-8
IC103	D-6
IC105	B-7
IC201	H-3
IC202	F-3
IC203	H-6
IC204	F-5
IC301	E-3
IC303	D-5
IC304	D-5
IC401	E-14
Q101	D-5
Q102	C-5
Q103	B-6
Q201	H-5

BD Board

Ref. No.	Location
IC101	G-8
IC102	G-9
Q101	G-8

4-3. PRINTED WIRING BOARDS ● Refer to page 22 for Semiconductor Lead Layouts.

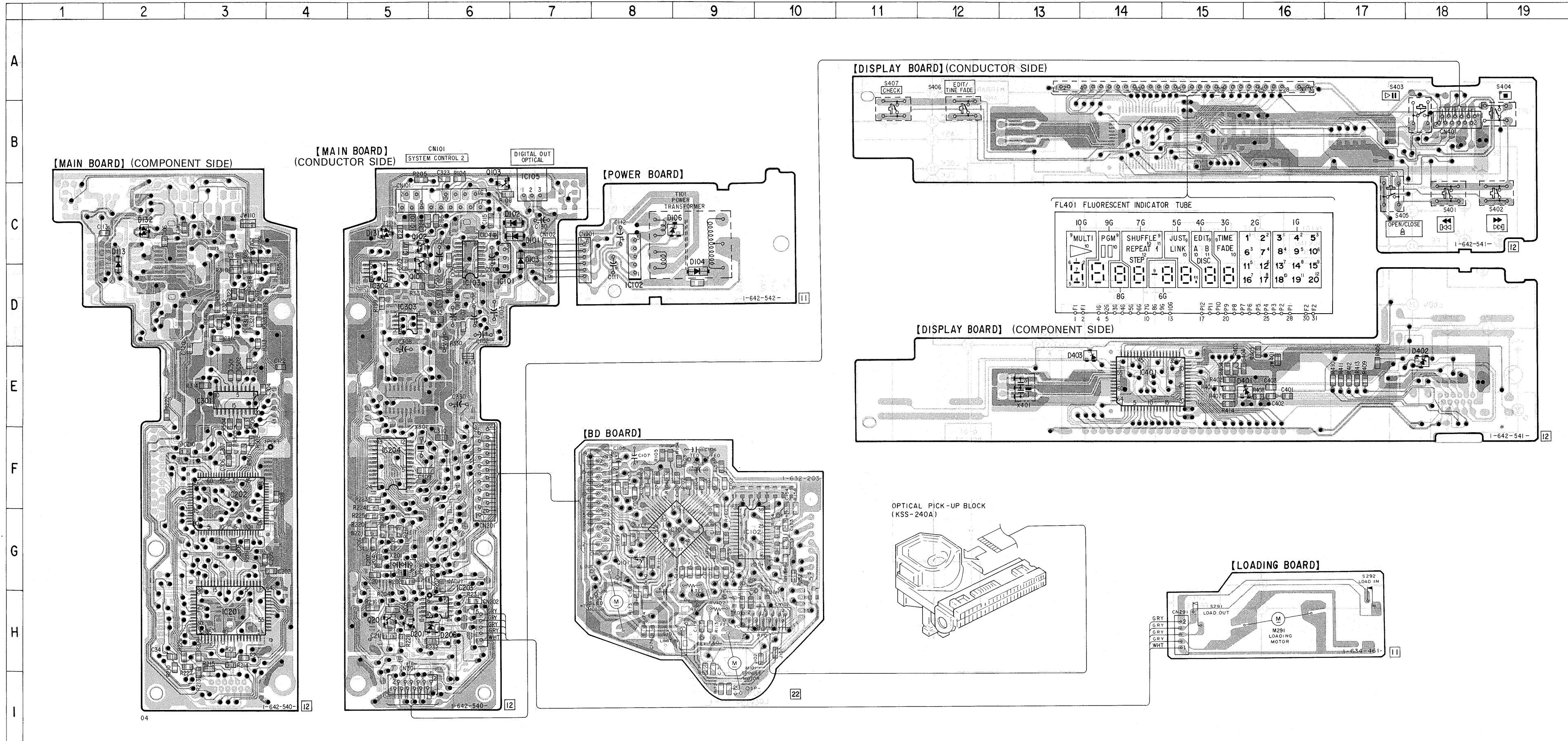

- Note:
- — : parts extracted from the component side.
 - : Through hole.
 - ▨ : Pattern on the side which is seen.
 - ▩ : Pattern of the rear side.

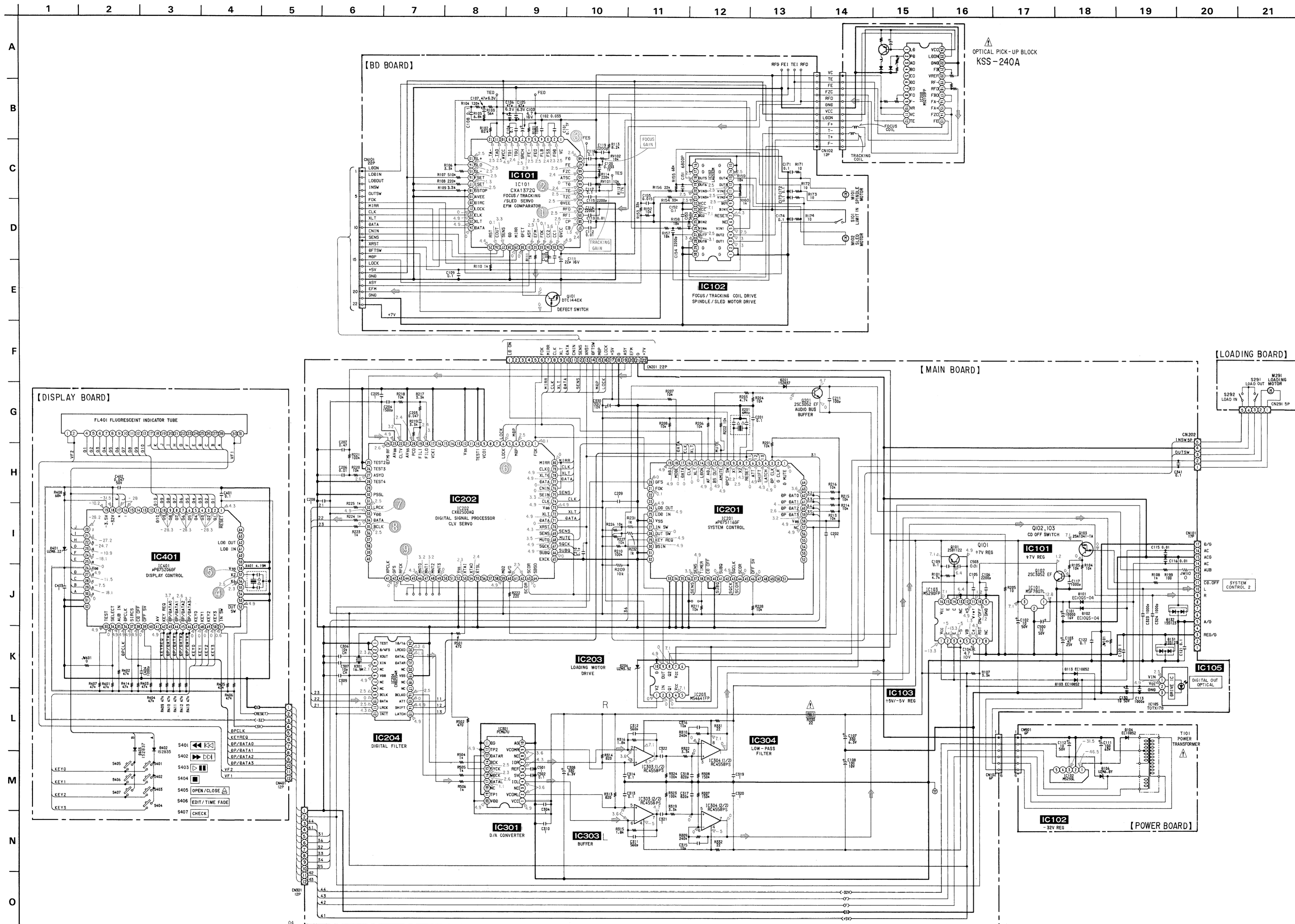

• Waveforms

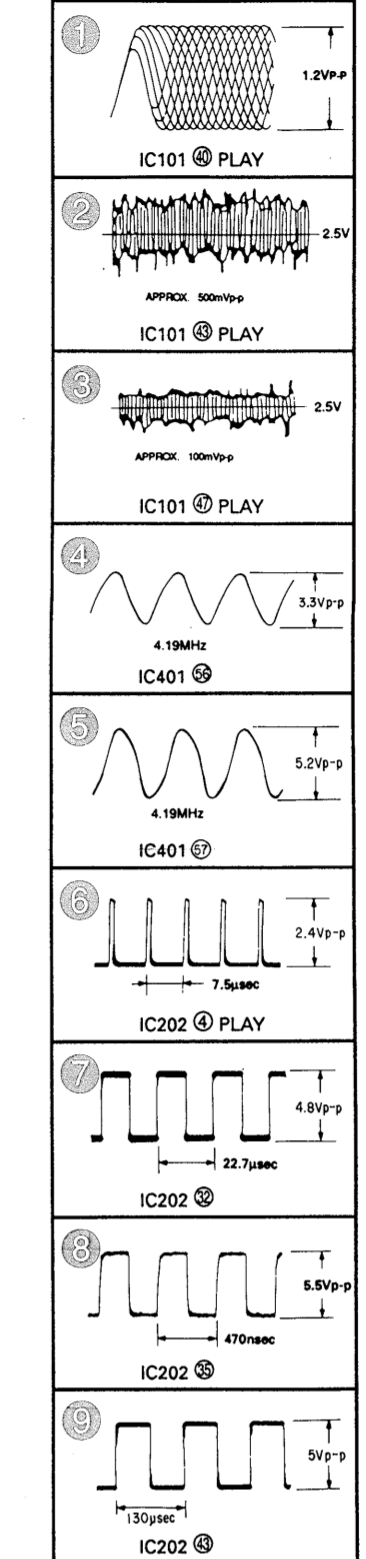

Note:

- All capacitors are in μF unless otherwise noted. pF : μF 50WV or less are not indicated except for electrolytics and tantalums.
- All resistors are in Ω and $\frac{1}{2}\text{W}$ or less unless otherwise specified.
- Δ : internal component.
- \square : nonflammable resistor.

Note: The components identified by mark Δ or dotted line with mark Δ are critical for safety. Replace only with part number specified.

- : B+ Line
- : B- Line
- : adjustment for repair.
- : Voltage and waveforms are dc with respect to ground under no-signal conditions.
- : Voltages are taken with a VOM (Input Impedance 10M Ω). Voltage variations may be noted due to normal production tolerances.
- : Waveforms are taken with an oscilloscope. Voltage variations may be noted due to normal production tolerances.
- : Circled numbers refer to waveforms.
- Signal path.
- : CD

• IC Block Diagrams

IC101 CXA1372Q (BD Board)

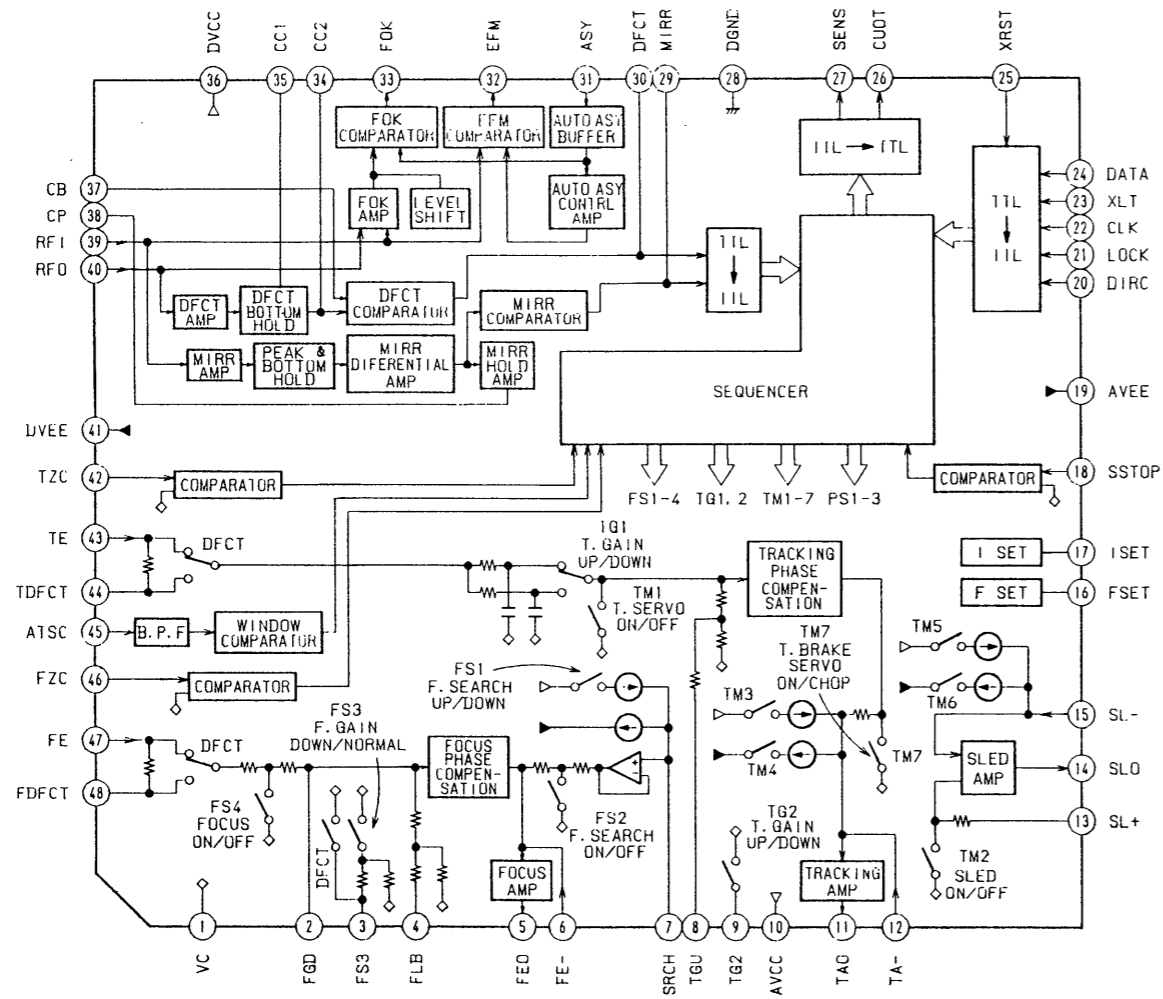

IC202 CXD2500AQ

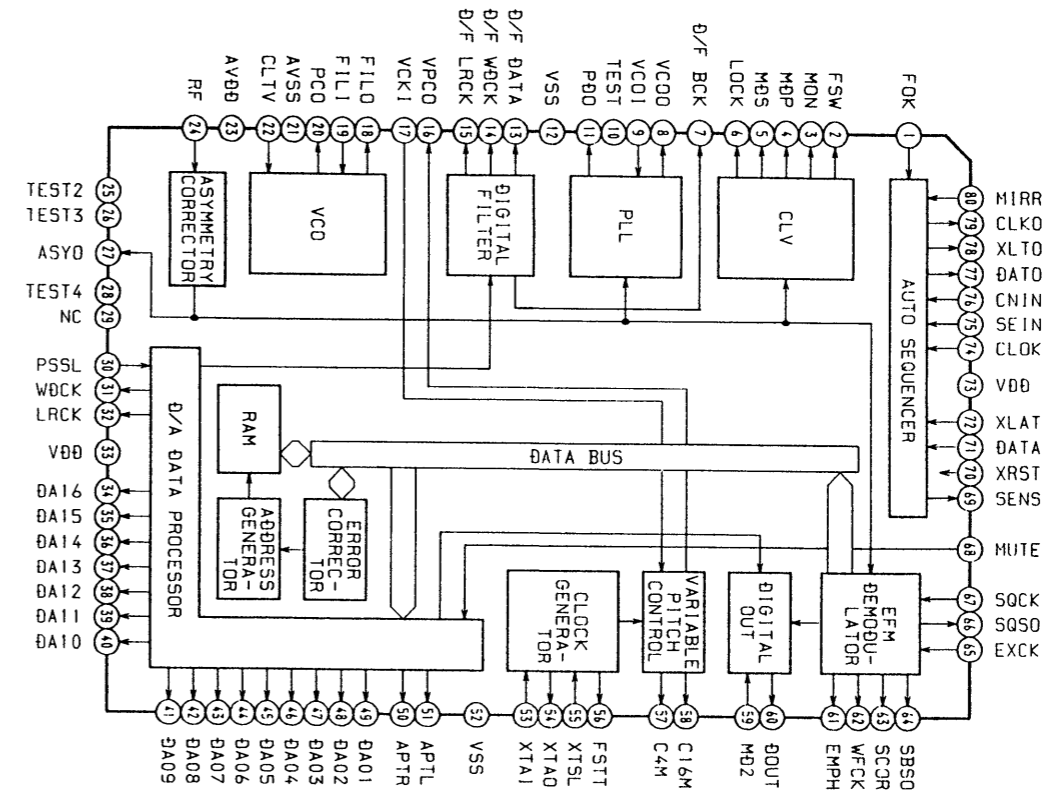

IC102 M5293L (Power Board)

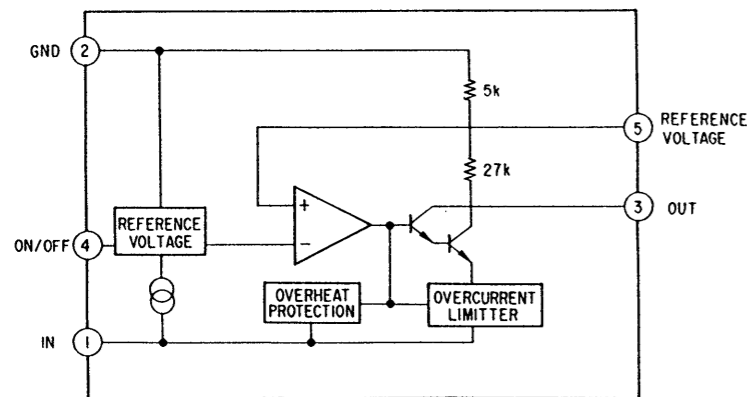

IC102 LA6532M (BD Board)

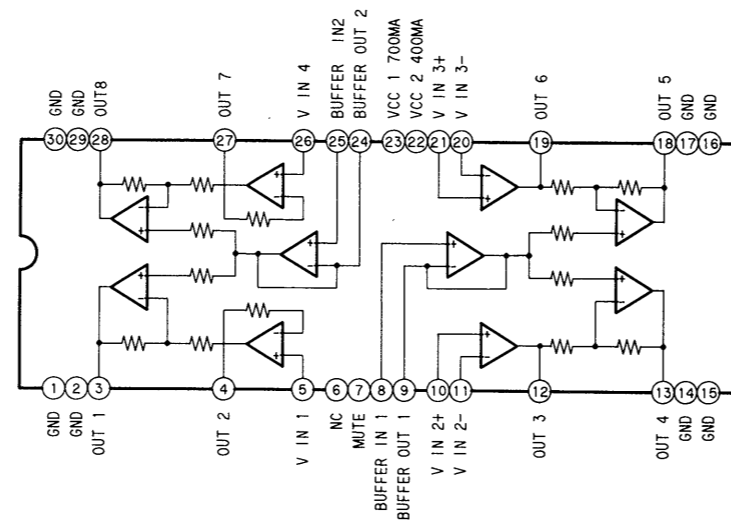

IC103 M5290FP

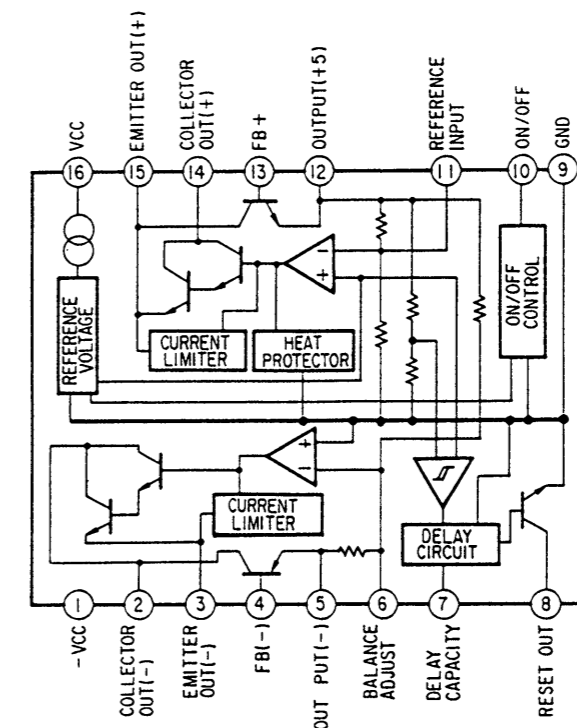

IC203 M54641FP

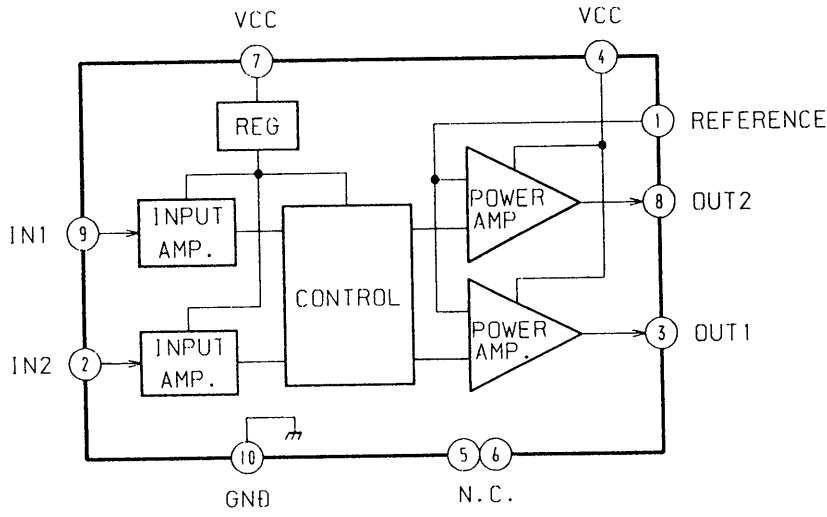

IC204 CXD2554M

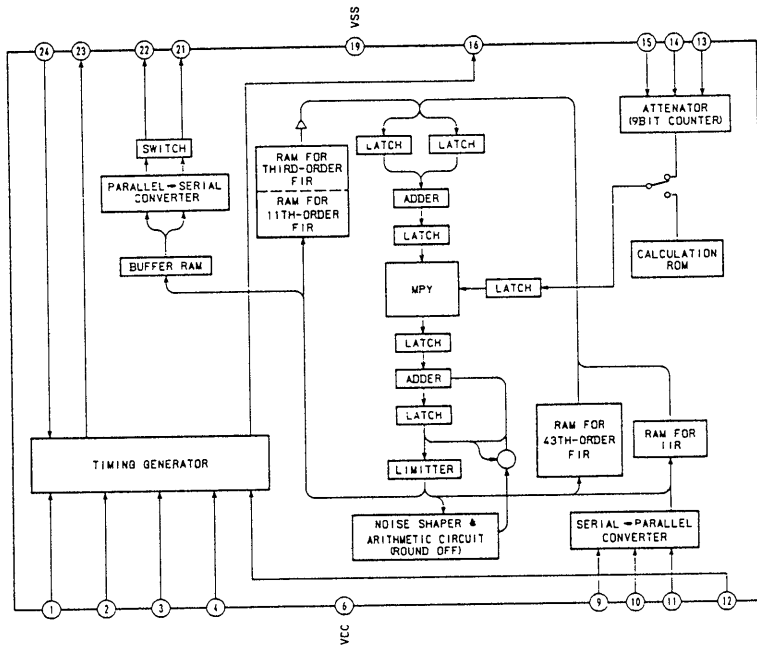

4-5. SEMICONDUCTOR LEAD LAYOUTS

CXA1372AQ

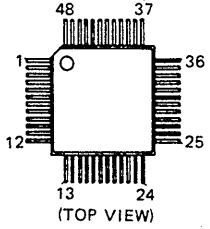

M5293L

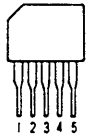

**DTC144EK
2SC3052-EF**

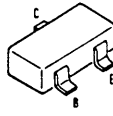

UZM8.2Z

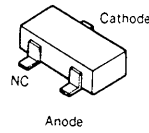

CXD2500AQ

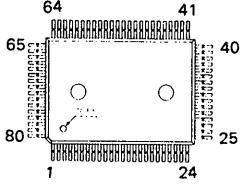

M54641FP

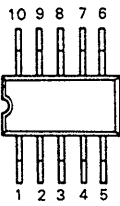

2SA1341

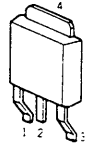

1 BASE
2 COLLECTOR
3 EMITTER
4 COLLECTOR

1SS226

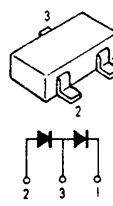

CXD2554M

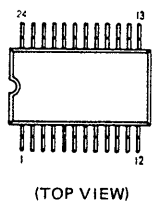

**PCM67U
PCM67U-A**

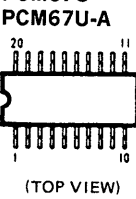

2SB1122-S

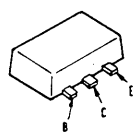

1S2836

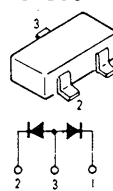

LA6532M

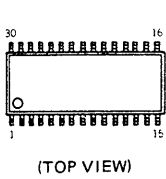

RC4558PS

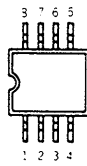

**EC10DS2
EC10QS-04**

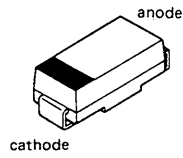

M5F7807

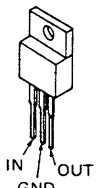

**μPD75116GF
-F21-3BE
μPD75206GF
-716-3BE**

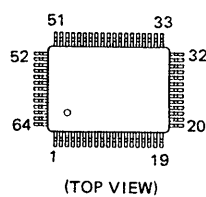

MA152WK

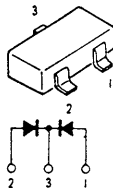

M5290FP

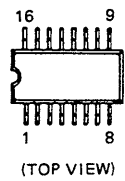

**UZM3.9Z
UZM6.8Y**

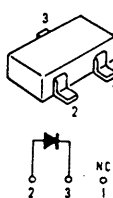

SECTION 5 EXPLODED VIEWS

NOTE:

- The mechanical parts with no reference number in the exploded views are not supplied.
- Items marked "*" are not stocked since they are seldom required for routine service. Some delay should be anticipated when ordering these items.

- -XX, -X mean standardized parts, so they may have some differences from the original one.

- Color Indication of Appearance Parts
Example:
KNOB, BALANCE (WHITE)...(RED)

Parts Color Cabinet's Color

- Hardware (# mark) list is given in the last of this parts list.

The components identified by mark or dotted line with mark are critical for safety. Replace only with part number specified.

- AUS: Australian model
- TR : Tourist model

5-1. CHASSIS

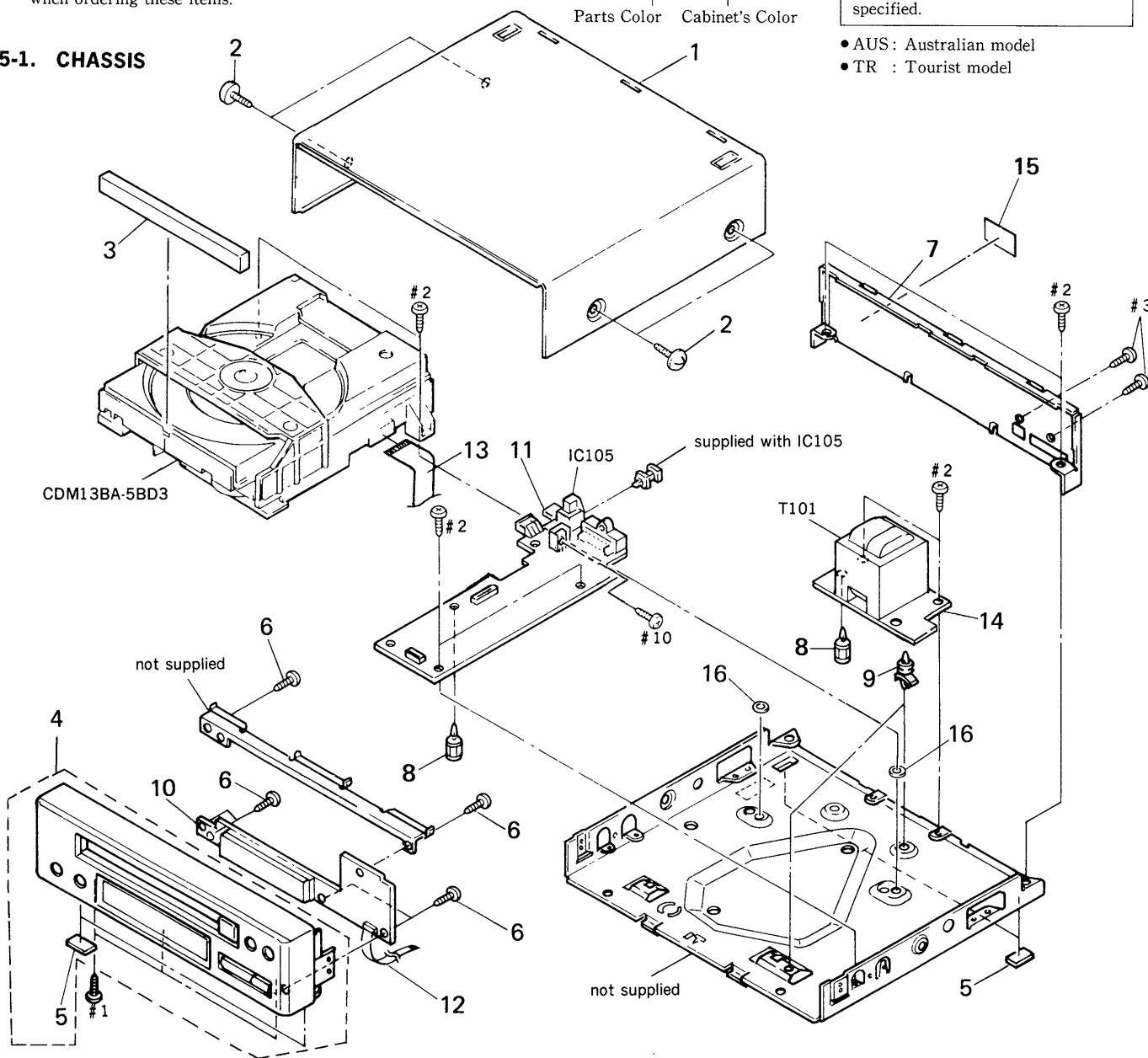

Ref. No.	Part No.	Description	Remark
* 1	4-944-423-31	CASE (K206522)	
2	3-363-099-01	SCREW (CASE +3X8 TP2)	
3	4-948-777-01	PANEL, LOADING	
4	X-4942-117-1	PANEL ASSY, FRONT	
5	4-930-336-21	FOOT (FELT)	
6	4-951-620-01	SCREW (2. 6X8), +BVTP	
* 7	4-948-753-11	PANEL (CDP), BACK (AEP, UK, AUS)	
* 7	4-948-753-32	PANEL (CDP), BACK (E, TR)	
* 8	3-669-610-00	SPACER	
* 9	4-924-098-11	HOLDER, PC BOARD	
* 10	A-4649-273-A	DISPLAY BOARD, COMPLETE	

Ref. No.	Part No.	Description	Remark
* 11	A-4649-275-A	MAIN BOARD, COMPLETE (AEP, UK, AUS)	
* 11	A-4649-368-A	MAIN BOARD, COMPLETE (E, TR)	
12	1-575-001-11	WIRE, FLAT TYPE (12 CORE)	
13	1-690-753-11	WIRE (FLAT TYPE) (22 CORE)	
* 14	1-642-542-11	POWER BOARD	
* 15	4-941-548-01	LABEL, CLASS 1	
16	3-555-872-00	SPACER	
IC105	8-749-923-04	IC TOTX178	
T101	1-450-704-11	TRANSFORMER, POWER (AEP, UK, AUS)	
T101	1-450-341-11	TRANSFORMER, POWER (E, TR)	

5-2. CD BLOCK (CDM13BA-5BD3)

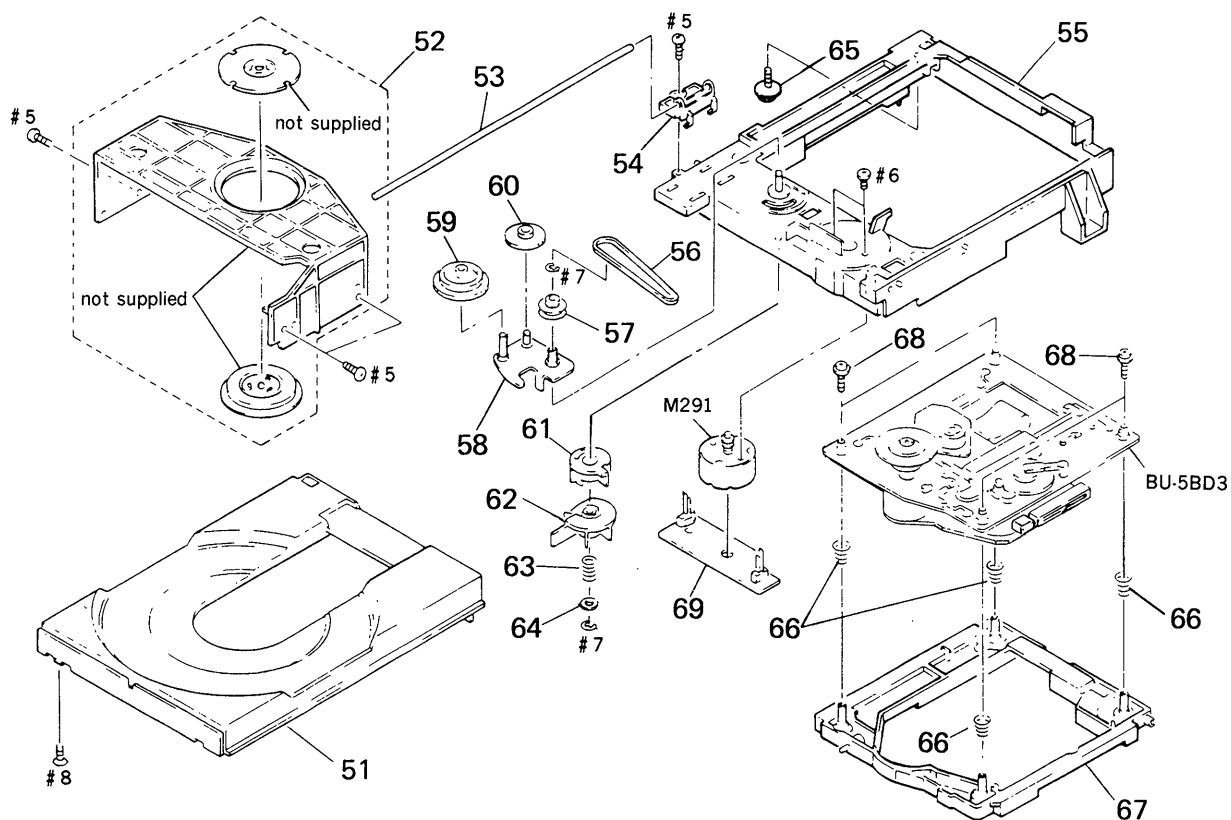

Ref. No.	Part No.	Description	Remark
51	4-944-012-01	TABLE, DISC	
52	A-4604-752-A	HOLDER (MG) ASSY	
53	4-929-764-01	SHAFT (TABLE GUIDE)	
54	4-944-006-01	BEARING	
55	X-4941-462-1	CHASSIS (MD) ASSY	
56	4-927-649-01	BELT	
57	4-929-724-01	PULLEY (B)	
58	X-4929-703-1	ARM ASSY, SWING	
59	4-927-620-01	GEAR (P)	
60	4-927-628-01	GEAR (C)	

Ref. No.	Part No.	Description	Remark
61	4-929-727-01	CAM (A)	
62	4-929-729-01	CAM (B)	
63	3-659-338-00	SPRING, COMPRESSION	
64	4-927-654-01	WASHER (LIMITER)	
* 65	4-917-583-21	BRACKET, YOKE	
66	4-917-541-01	SPRING (B)	
67	4-929-747-01	HOLDER (BU)	
68	4-933-134-01	SCREW (+PTPWH M2. 6X6)	
* 69	1-634-461-11	LOADING BOARD	
M291	A-4608-362-A	MOTOR (L) ASSY	

5-3. OPTICAL PICK-UP BLOCK (BU-5BD3)

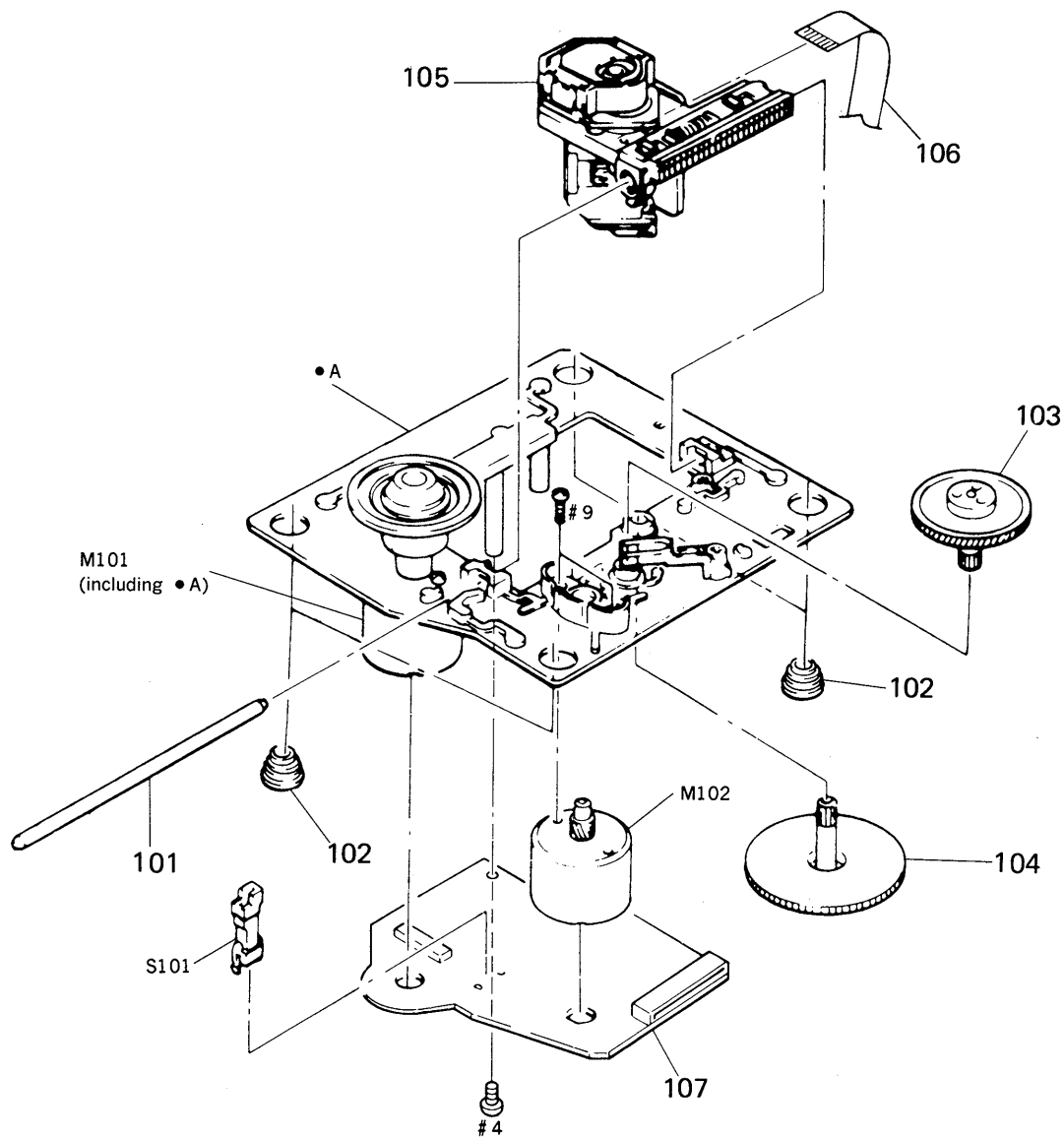

Note: The components identified by mark \triangle or dotted line with mark \triangle are critical for safety. Replace only with part number specified.

Ref. No.	Part No.	Description	Remark
101	4-917-565-01	SHAFT, SLED	
102	4-933-126-01	INSULATOR (A)	
103	4-917-567-01	GEAR (M)	
104	4-917-564-01	GEAR (P), FLATNESS	
\triangle 105	8-848-144-11	DEVICE, OPTICAL KSS-240A	

Ref. No.	Part No.	Description	Remark
106	1-575-001-11	WIRE, FLAT TYPE (12 CORE)	
* 107	A-4617-371-A	BD BOARD, COMPLETE	
M101	X-4917-523-3	MOTOR ASSY, SPINDLE	
M102	X-4917-504-1	MOTOR ASSY, SLED	
S101	1-572-085-11	SWITCH, LEAF (LIMIT IN)	

BD

SECTION 6 ELECTRICAL PARTS LIST

NOTE :

- Due to standardization, replacements in the parts list may be different from the parts specified in the diagrams or the components used on the set.
- -XX, -X mean standardized parts, so they may have some differences from the original one.
- Items marked "*" are not stocked since they are seldom required for routine service. Some delay should be anticipated when ordering these items.
- CAPACITORS
uF: μ F

- RESISTORS
All resistors are in ohms
METAL : Metal-film resistor
METAL OXIDE : Metal Oxide-film resistor
F : nonflammable
- COILS
uH : μ H
- SEMICONDUCTORS
In each case, u: μ , for example:
uA... : μ A..., uPA... : μ PA...,
uPB... : μ PB..., uPC... : μ PC...,
uPD... : μ PD....

When indicating parts by reference number, please include the board name.

The components identified by mark Δ or dotted line with mark Δ are critical for safety. Replace only with part number specified.

- AUS : Australian model
- TR : Tourist model

Ref.No.	Part No.	Description	Remark
*	A-4617-371-A	BD BOARD, COMPLETE *****	
		< CAPACITOR >	
C101	1-163-038-00	CERAMIC CHIP 0.1uF	25V
C102	1-163-989-11	CERAMIC CHIP 0.033uF	10% 25V
C103	1-126-163-11	ELECT 4.7uF	20% 50V
C104	1-163-038-00	CERAMIC CHIP 0.1uF	25V
C105	1-126-154-11	ELECT 47uF	20% 6.3V
C106	1-126-154-11	ELECT 47uF	20% 6.3V
C107	1-126-154-11	ELECT 47uF	20% 6.3V
C108	1-163-038-00	CERAMIC CHIP 0.1uF	25V
C109	1-163-038-00	CERAMIC CHIP 0.1uF	25V
C110	1-163-989-11	CERAMIC CHIP 0.033uF	10% 25V
C111	1-131-367-00	TANTALUM 22uF	10% 20V
C112	1-164-232-11	CERAMIC CHIP 0.01uF	50V
C113	1-164-232-11	CERAMIC CHIP 0.01uF	50V
C114	1-164-161-11	CERAMIC CHIP 0.0022uF	10% 100V
C115	1-164-161-11	CERAMIC CHIP 0.0022uF	10% 100V
C117	1-163-038-00	CERAMIC CHIP 0.1uF	25V
C118	1-163-038-00	CERAMIC CHIP 0.1uF	25V
C119	1-164-161-11	CERAMIC CHIP 0.0022uF	10% 100V
C120	1-163-989-11	CERAMIC CHIP 0.033uF	10% 25V
C151	1-163-019-00	CERAMIC CHIP 0.0068uF	10% 50V
C152	1-163-038-00	CERAMIC CHIP 0.1uF	25V
C153	1-163-006-11	CERAMIC CHIP 560PF	10% 50V
C154	1-164-161-11	CERAMIC CHIP 0.0022uF	10% 100V
C155	1-163-023-00	CERAMIC CHIP 0.015uF	5% 50V
C171	1-163-038-00	CERAMIC CHIP 0.1uF	25V
C172	1-163-038-00	CERAMIC CHIP 0.1uF	25V
C173	1-163-038-00	CERAMIC CHIP 0.1uF	25V
C174	1-163-038-00	CERAMIC CHIP 0.1uF	25V
		< CONNECTOR >	
CN101	1-568-796-11	SOCKET, CONNECTOR 22P	
CN102	1-568-795-11	SOCKET, CONNECTOR 12P	
		< IC >	
IC101	8-752-053-73	IC CXA1372AQ	

Ref.No.	Part No.	Description	Remark
IC102	8-759-822-36	IC LA6532M	
		< JUMPER RESISTOR >	
J101	1-216-295-00	METAL CHIP 0 5%	1/10W
J102	1-216-295-00	METAL CHIP 0 5%	1/10W
		< TRANSISTOR >	
Q101	8-729-901-01	TRANSISTOR DTC144EK	
		< RESISTOR >	
R101	1-216-097-00	METAL CHIP 100K 5%	1/10W
R102	1-216-095-00	METAL CHIP 82K 5%	1/10W
R103	1-216-091-00	METAL CHIP 56K 5%	1/10W
R104	1-216-099-00	METAL CHIP 120K 5%	1/10W
R105	1-216-069-00	METAL CHIP 6.8K 5%	1/10W
R106	1-216-061-00	METAL CHIP 3.3K 5%	1/10W
R107	1-216-114-00	METAL GLAZE 510K 5%	1/10W
R108	1-216-105-00	METAL CHIP 220K 5%	1/10W
R109	1-216-061-00	METAL CHIP 3.3K 5%	1/10W
R110	1-216-049-00	METAL CHIP 1K 5%	1/10W
R111	1-216-049-00	METAL CHIP 1K 5%	1/10W
R112	1-216-083-00	METAL CHIP 27K 5%	1/10W
R113	1-216-071-00	METAL CHIP 8.2K 5%	1/10W
R114	1-216-105-00	METAL CHIP 220K 5%	1/10W
R152	1-216-073-00	METAL CHIP 10K 5%	1/10W
R153	1-216-085-00	METAL CHIP 33K 5%	1/10W
R154	1-216-085-00	METAL CHIP 33K 5%	1/10W
R155	1-216-093-00	METAL CHIP 68K 5%	1/10W
R156	1-216-081-00	METAL CHIP 22K 5%	1/10W
R157	1-216-079-00	METAL CHIP 18K 5%	1/10W
R158	1-216-079-00	METAL CHIP 18K 5%	1/10W
R159	1-216-079-00	METAL CHIP 18K 5%	1/10W
R160	1-216-049-00	METAL CHIP 1K 5%	1/10W
R171	1-216-001-00	METAL CHIP 10 5%	1/10W
R172	1-216-001-00	METAL CHIP 10 5%	1/10W
R173	1-216-001-00	METAL CHIP 10 5%	1/10W
R174	1-216-001-00	METAL CHIP 10 5%	1/10W

BD

DISPLAY

MAIN

POWER

Ref. No.	Part No.	Description	Remark
		< VARIABLE RESISTOR >	
RV101	1-238-016-11	RES, ADJ, CARBON 10K	
RV102	1-238-016-11	RES, ADJ, CARBON 10K	
		< SWITCH >	
S101	1-572-085-11	SWITCH, LEAF (LIMIT IN)	

*	A-4649-273-A	DISPLAY BOARD, COMPLETE	

*	A-4649-275-A	MAIN BOARD, COMPLETE (AEP, UK, AUS)	
*	A-4649-368-A	MAIN BOARD, COMPLETE (E, TR)	

*	1-642-542-11	POWER BOARD	

*	4-880-403-11	HEAT SINK	
*	4-932-810-11	CUSHION (FL)	
	7-682-548-04	SCREW +BVTT 3X8 (S)	
		< CAPACITOR >	
C101	1-126-939-11	ELECT 10000uF	20% 16V
C102	1-124-907-11	ELECT 10uF	20% 50V
C103	1-124-477-11	ELECT 47uF	20% 25V
C104	1-135-155-21	TANTALUM CHIP 4.7uF	10% 16V
C105	1-164-346-11	CERAMIC CHIP 1uF	16V
C106	1-164-695-11	CERAMIC CHIP 0.0022uF	5% 50V
C107	1-124-442-00	ELECT 330uF	20% 6.3V
C108	1-124-443-00	ELECT 100uF	20% 10V
C109	1-163-038-00	CERAMIC CHIP 0.1uF	25V
C111	1-126-063-11	ELECT 100uF	20% 63V
C112	1-124-907-11	ELECT 10uF	20% 50V
C113	1-163-141-00	CERAMIC CHIP 0.001uF	5% 50V
C115	1-163-031-11	CERAMIC CHIP 0.01uF	50V
C116	1-163-031-11	CERAMIC CHIP 0.01uF	50V
C117	1-163-141-00	CERAMIC CHIP 0.001uF	5% 50V
C120	1-164-346-11	CERAMIC CHIP 1uF	16V
C121	1-163-038-00	CERAMIC CHIP 0.1uF	25V
C122	1-163-038-00	CERAMIC CHIP 0.1uF	25V
C130	1-124-907-11	ELECT 10uF	20% 50V
C201	1-163-038-00	CERAMIC CHIP 0.1uF	25V
C202	1-164-346-11	CERAMIC CHIP 1uF	16V
C203	1-163-035-00	CERAMIC CHIP 0.047uF	50V
C204	1-163-145-00	CERAMIC CHIP 0.0015uF	5% 50V
C205	1-164-346-11	CERAMIC CHIP 1uF	16V
C206	1-163-031-11	CERAMIC CHIP 0.01uF	50V
C207	1-164-005-11	CERAMIC CHIP 0.47uF	25V
C208	1-164-346-11	CERAMIC CHIP 1uF	16V
C209	1-164-346-11	CERAMIC CHIP 1uF	16V
C210	1-163-038-00	CERAMIC CHIP 0.1uF	25V

Ref. No.	Part No.	Description	Remark
C211	1-163-117-00	CERAMIC CHIP 100PF	5% 50V
C304	1-164-346-11	CERAMIC CHIP 1uF	16V
C306	1-163-227-11	CERAMIC CHIP 10PF	5% 50V
C307	1-163-227-11	CERAMIC CHIP 10PF	5% 50V
C308	1-124-442-00	ELECT 330uF	20% 6.3V
C309	1-162-638-11	CERAMIC CHIP 1uF	16V
C310	1-164-346-11	CERAMIC CHIP 1uF	16V
C311	1-163-006-11	CERAMIC CHIP 560PF	10% 50V
C312	1-163-006-11	CERAMIC CHIP 560PF	10% 50V
C313	1-163-038-00	CERAMIC CHIP 0.1uF	25V
C314	1-163-038-00	CERAMIC CHIP 0.1uF	25V
C315	1-163-227-11	CERAMIC CHIP 10PF	5% 50V
C316	1-163-227-11	CERAMIC CHIP 10PF	5% 50V
C317	1-163-139-00	CERAMIC CHIP 820PF	5% 50V
C318	1-163-139-00	CERAMIC CHIP 820PF	5% 50V
C319	1-164-346-11	CERAMIC CHIP 1uF	16V
C320	1-164-346-11	CERAMIC CHIP 1uF	16V
C321	1-164-346-11	CERAMIC CHIP 1uF	16V
C322	1-164-346-11	CERAMIC CHIP 1uF	16V
C323	1-163-141-00	CERAMIC CHIP 0.001uF	5% 50V
C324	1-163-141-00	CERAMIC CHIP 0.001uF	5% 50V
C330	1-124-442-00	ELECT 330uF	20% 10V
C341	1-163-038-00	CERAMIC CHIP 0.1uF	25V
C401	1-163-038-00	CERAMIC CHIP 0.1uF	25V
C402	1-163-035-00	CERAMIC CHIP 0.047uF	50V
C403	1-164-346-11	CERAMIC CHIP 1uF	16V
C404	1-163-009-11	CERAMIC CHIP 0.001uF	10% 50V
C500	1-124-907-11	ELECT 10uF	20% 50V
C501	1-164-346-11	CERAMIC CHIP 1uF	16V
C502	1-163-038-00	CERAMIC CHIP 0.1uF	25V
C503	1-163-031-11	CERAMIC CHIP 0.01uF	50V
		< CONNECTOR >	
* CN101	1-569-624-11	SOCKET, CONNECTOR 17P(SYSTEM CONTROL 2)	
CN102	1-568-662-11	CONNECTOR, BOARD TO BOARD 6P	
* CN201	1-568-822-11	SOCKET, CONNECTOR 22P	
* CN202	1-564-339-00	PIN, CONNECTOR 5P	
* CN301	1-573-099-11	HOUSING, CONNECTOR 12P	
* CN401	1-573-098-11	HOUSING, CONNECTOR 12P	
CN901	1-568-668-11	CONNECTOR, BOARD TO BOARD 6P	
		< DIODE >	
D101	8-719-210-39	DIODE EC10QS-04	
D102	8-719-210-39	DIODE EC10QS-04	
D103	8-719-210-33	DIODE EC10DS2	
D104	8-719-210-33	DIODE EC10DS2	
D106	8-719-021-59	DIODE UZM6.8Y	
D113	8-719-210-33	DIODE EC10DS2	

DISPLAY

MAIN

POWER

Ref. No.	Part No.	Description	Remark	Ref. No.	Part No.	Description	Remark
D131	8-719-800-76	DIODE 1SS226		R205	1-216-001-00	METAL CHIP 10 5% 1/10W	
D132	8-719-800-76	DIODE 1SS226		R206	1-216-073-00	METAL CHIP 10K 5% 1/10W	
D201	8-719-400-18	DIODE MA152WK		R207	1-216-073-00	METAL CHIP 10K 5% 1/10W	
D206	8-719-021-13	DIODE UZM3. 9Z		R208	1-216-073-00	METAL CHIP 10K 5% 1/10W	
D401	8-719-021-77	DIODE UZM8. 2Z		R209	1-216-073-00	METAL CHIP 10K 5% 1/10W	
D402	8-719-104-34	DIODE 1S2836		R210	1-216-097-00	METAL CHIP 100K 5% 1/10W	
D403	8-719-400-18	DIODE MA152WK		R211	1-216-073-00	METAL CHIP 10K 5% 1/10W	
		< INDICATOR >		R213	1-216-073-00	METAL CHIP 10K 5% 1/10W	
FL401	1-519-652-11	INDICATOR TUBE, FLUORESCENT		R214	1-216-073-00	METAL CHIP 10K 5% 1/10W	
		< IC >		R215	1-216-073-00	METAL CHIP 10K 5% 1/10W	
IC101	8-759-604-86	IC M5F7807		R216	1-216-073-00	METAL CHIP 10K 5% 1/10W	
IC102	8-759-633-42	IC M5293L		R217	1-216-061-00	METAL CHIP 3. 3K 5% 1/10W	
IC103	8-759-636-24	IC M5290FP		R218	1-216-073-00	METAL CHIP 10K 5% 1/10W	
IC105	8-749-923-04	IC TOTX178		R219	1-216-061-00	METAL CHIP 3. 3K 5% 1/10W	
IC201	8-759-059-86	IC uPD75116GF-F21-3BE		R220	1-216-073-00	METAL CHIP 10K 5% 1/10W	
IC202	8-752-337-26	IC CXD2500AQ		R221	1-216-097-00	METAL CHIP 100K 5% 1/10W	
IC203	8-759-636-20	IC M54641FP		R222	1-216-033-00	METAL CHIP 220 5% 1/10W	
IC204	8-752-337-10	IC CXD2554M		R223	1-216-049-00	METAL CHIP 1K 5% 1/10W	
IC301	8-759-506-63	IC PCM67U (AEP, UK, AUS)		R224	1-216-049-00	METAL CHIP 1K 5% 1/10W	
IC301	8-759-070-98	IC PCM67U-A (E, TR)		R225	1-216-049-00	METAL CHIP 1K 5% 1/10W	
IC303	8-759-996-43	IC RC4558PS		R226	1-216-073-00	METAL CHIP 10K 5% 1/10W	
IC304	8-759-996-43	IC RC4558PS		R227	1-216-073-00	METAL CHIP 10K 5% 1/10W	
IC401	8-759-154-14	IC uPD75206GF-716-3BE		R228	1-216-073-00	METAL CHIP 10K 5% 1/10W	
		< JUMPER RESISTOR >		R231	1-216-049-00	METAL CHIP 1K 5% 1/10W	
JW101	1-216-296-00	METAL CHIP 0 5% 1/8W		R232	1-216-049-00	METAL CHIP 1K 5% 1/10W	
JW110	1-216-296-00	METAL CHIP 0 5% 1/8W		R307	1-216-101-00	METAL CHIP 150K 5% 1/10W	
JW401	1-216-295-00	METAL CHIP 0 5% 1/10W		R308	1-216-101-00	METAL CHIP 150K 5% 1/10W	
		< TRANSISTOR >		R309	1-216-106-00	METAL CHIP 240K 5% 1/10W	
Q101	8-729-804-41	TRANSISTOR 2SB1122-S		R310	1-216-106-00	METAL CHIP 240K 5% 1/10W	
Q102	8-729-620-06	TRANSISTOR 2SC3052-EF		R313	1-216-047-00	METAL CHIP 820 5% 1/10W	
Q103	8-729-805-69	TRANSISTOR 2SA1341		R314	1-216-047-00	METAL CHIP 820 5% 1/10W	
Q201	8-729-620-06	TRANSISTOR 2SC3052-EF		R315	1-216-055-00	METAL CHIP 1. 8K 5% 1/10W	
		< RESISTOR >		R316	1-216-055-00	METAL CHIP 1. 8K 5% 1/10W	
R101	1-216-065-00	METAL CHIP 4. 7K 5% 1/10W		R319	1-216-061-00	METAL CHIP 3. 3K 5% 1/10W	
R104	1-216-073-00	METAL CHIP 10K 5% 1/10W		R322	1-216-061-00	METAL CHIP 3. 3K 5% 1/10W	
R105	1-216-073-00	METAL CHIP 10K 5% 1/10W		R323	1-216-097-00	METAL CHIP 100K 5% 1/10W	
R107	1-216-061-00	METAL CHIP 3. 3K 5% 1/10W		R324	1-216-097-00	METAL CHIP 100K 5% 1/10W	
R108	1-216-049-00	METAL CHIP 1K 5% 1/10W		△R330	1-249-397-11	CARBON 22 5% 1/4W F	
R199	1-216-025-00	METAL CHIP 100 5% 1/10W		R331	1-216-009-00	METAL CHIP 22 5% 1/10W	
R201	1-216-073-00	METAL CHIP 10K 5% 1/10W		R332	1-216-009-00	METAL CHIP 22 5% 1/10W	
R202	1-216-073-00	METAL CHIP 10K 5% 1/10W		R401	1-216-089-00	METAL CHIP 47K 5% 1/10W	
R203	1-216-065-00	METAL CHIP 4. 7K 5% 1/10W		R402	1-216-089-00	METAL CHIP 47K 5% 1/10W	
R204	1-216-073-00	METAL CHIP 10K 5% 1/10W		R403	1-216-089-00	METAL CHIP 47K 5% 1/10W	
				R404	1-216-089-00	METAL CHIP 47K 5% 1/10W	
				R405	1-216-089-00	METAL CHIP 47K 5% 1/10W	
				R406	1-216-089-00	METAL CHIP 47K 5% 1/10W	
				R407	1-216-089-00	METAL CHIP 47K 5% 1/10W	
				R408	1-216-093-00	METAL CHIP 68K 5% 1/10W	
				R409	1-216-089-00	METAL CHIP 47K 5% 1/10W	

Note: The components identified by mark Δ or dotted line with mark Δ are critical for safety. Replace only with part number specified.

DISPLAY

MAIN

POWER

LOADING

Ref. No.	Part No.	Description	Remark
R410	1-216-089-00	METAL CHIP	47K 5% 1/10W
R411	1-216-089-00	METAL CHIP	47K 5% 1/10W
R412	1-216-089-00	METAL CHIP	47K 5% 1/10W
R413	1-216-089-00	METAL CHIP	47K 5% 1/10W
R414	1-216-089-00	METAL CHIP	47K 5% 1/10W
R501	1-216-041-00	METAL CHIP	470 5% 1/10W
R502	1-216-041-00	METAL CHIP	470 5% 1/10W
R504	1-216-049-00	METAL CHIP	1K 5% 1/10W
R505	1-216-049-00	METAL CHIP	1K 5% 1/10W
R506	1-216-049-00	METAL CHIP	1K 5% 1/10W

< SWITCH >

S401	1-554-303-21	SWITCH, TACTILE (◀▶)
S402	1-554-303-21	SWITCH, TACTILE (▶▶)
S403	1-554-303-21	SWITCH, TACTILE (▷)
S404	1-554-303-21	SWITCH, TACTILE (■)
S405	1-554-303-21	SWITCH, TACTILE (OPEN/CLOSE)
S406	1-554-303-21	SWITCH, TACTILE (EDIT/TIME FADE)
S407	1-554-303-21	SWITCH, TACTILE (CHECK)

< TRANSFORMER >

△T101	1-450-704-11	TRANSFORMER, POWER (AEP, UK, AUS)
△T101	1-450-341-11	TRANSFORMER, POWER (E, TR)

< VIBRATOR >

X201	1-577-358-21	VIBRATOR, CERAMIC (4MHz)
X301	1-567-908-11	VIBRATOR, CRYSTAL (16.9MHz)
X401	1-579-063-21	VIBRATOR, CERAMIC (4.19MHz)

*	1-634-461-11	LOADING BOARD
---	--------------	---------------

< CONNECTOR >

* CN291	1-564-498-11	PIN, CONNECTOR 5P
---------	--------------	-------------------

< SWITCH >

S291	1-571-924-11	SWITCH, LEAF (LOAD OUT)
S292	1-571-924-11	SWITCH, LEAF (LOAD IN)

Ref. No.	Part No.	Description	Remark
		MISCELLANEOUS	

12	1-575-001-11	WIRE, FLAT TYPE (12 CORE)	
13	1-690-753-11	WIRE (FLAT TYPE) (22 CORE)	
△105	8-848-144-11	DEVICE, OPTICAL KSS-240A	
106	1-575-001-11	WIRE, FLAT TYPE (12 CORE)	
M101	X-4917-523-3	MOTOR ASSY, SPINDLE	
M102	X-4917-504-1	MOTOR ASSY, SLED	
M291	A-4608-362-A	MOTOR (L) ASSY	

HARDWARE LIST

#1	7-682-547-09	SCREW +BVTT	3X6 (S)
#2	7-682-547-04	SCREW +BVTT	3X6 (S)
#3	7-685-647-79	SCREW +BVTP	3X10 TYPE2 N-S
#4	7-685-134-19	SCREW +BTP	2.6X8 TYPE2 N-S
#5	7-685-646-79	SCREW +BVTP	3X8 TYPE2 N-S
#6	7-621-775-10	SCREW +B	2.6X4
#7	7-624-105-04	STOP RING	2.3, TYPE -E
#8	7-685-234-19	SCREW +KTP	2.6X8 TYPE2NON-SLIT
#9	7-621-255-15	SCREW +P	2X3
#10	7-682-548-04	SCREW +BVTT	3X8 (S)

Note: The components identified by mark △ or dotted line with mark △ are critical for safety. Replace only with part number specified.

CDP-H3700

SONY[®] SERVICE MANUAL

AEP Model
UK Model
E Model
Australian Model
Tourist Model

SUPPLEMENT-1

File this supplement with the Service Manual.

Germany model has been added

- The Germany model has been designed based on the CDP-H3700. There for see the CDP-H3700 service manual for the information not contained in this supplement-1.

MODEL IDENTIFICATION

—BACK PANEL—

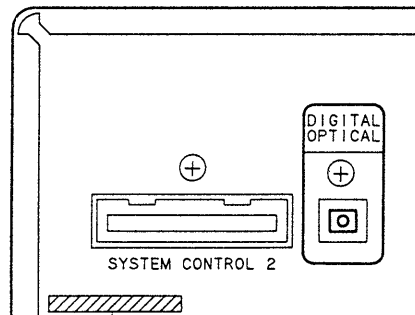

4-948-753-21 (AE4): Germany model

ELECTRICAL BLOCK CHECKING

Note :

1. CD Block basically constructed to operate without adjustment. Therefore, check each item in order given.
2. Use YEDS-18 disc (3-702-101-01) unless otherwise indicated.
3. Use the oscilloscope with more than 10MΩ impedance.
4. Clean an object lens by an applicator with neutral detergent when the signal level is low than specified value with the following checks.

S Curve Check

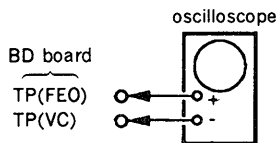

Procedure :

1. Connect oscilloscope to test point TP (FEO) on BD board.
2. Connect between test point TP (FES) and TP (VC) by lead wire.
3. Turned Power switch on and actuate the focus serch. (actuate the focus serch when disc table is moving in and out.)
4. Check the oscilloscope waveform (S curve) is symmetrical between A and B. And confirm peak to peak level within $3 \pm 1V_{p-p}$.

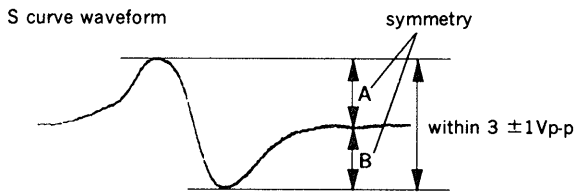

5. After check, remove the lead wire connected in step 2.
- Note :**
- Try to mesure several times to make sure that the ratio of A : B or B : A is more than 10 : 7.
 - Take sweep time as long as possible and light up the brightness to obtain best waveform.

RF Level Check

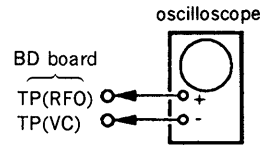

Procedure :

1. Connect oscilloscope to test point TP (RFO) on BD board.
2. Turn Power switch on.
3. Put disc (YEDS-18) in and playback.
4. Confirm that oscilloscope waveform is clear and check RF signal level is correct or not.

Note :

Clear RF signal waveform means that the shape “◇” can be clearly distinguished at the center of the waveform.

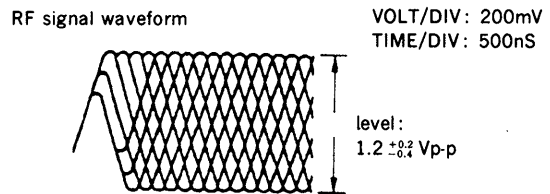

E-F Balance Check

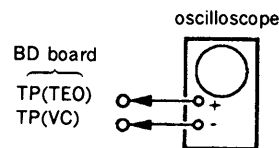

Procedure :

1. Connect test point TP (ADJ) to ground and TP (TES) to TP (VC) with lead wire.
2. Connect oscilloscope to test point TP (TEO) on BD board.
3. Turn Power switch on.
4. Put disc (YEDS-18) in and playback.
5. Confirm that the oscilloscope waveform is symmetrical on the top and bottom in relation to 0V, and check this level.

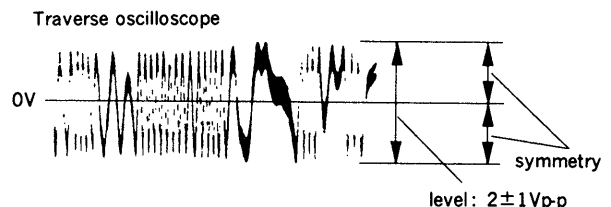

6. Remove the lead wire connected in step 1.

RF PLL Free-run Frequency Check

Procedure :

1. Connect frequency counter to test point (PCK) with lead wire.

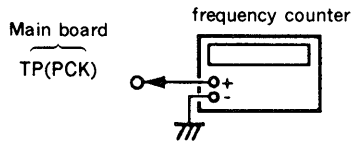

2. Turn Power switch on.
3. Confirm that reading on frequency counter is 4.3218MHz.

Focus/Tracking Gain

This gain has a margin, so even if it is slightly off.

There is no problem.

Therefore, do not perform, this adjustment.

Please note that it should be fixed to mechanical center position when you moved and do not know original position.

Checking Location :

[BD Board]

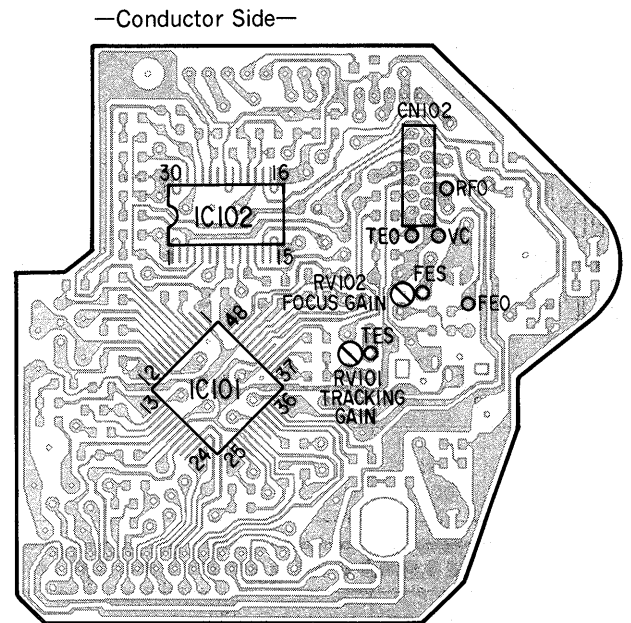

[MAIN Board] —Component Side—

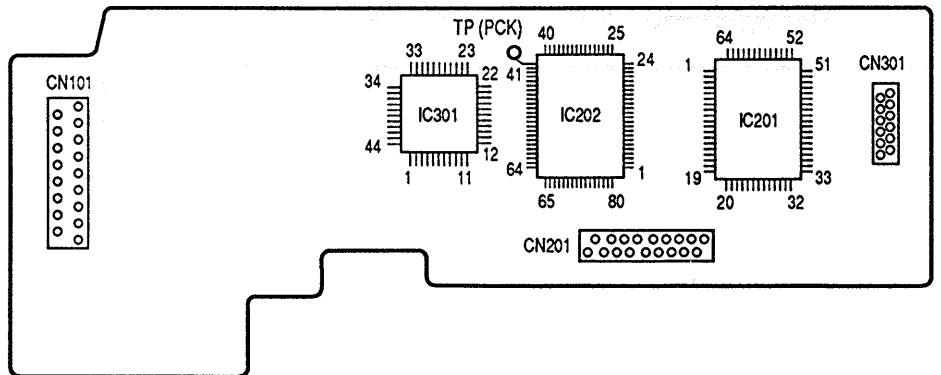

[MAIN Board] —Conductor Side—

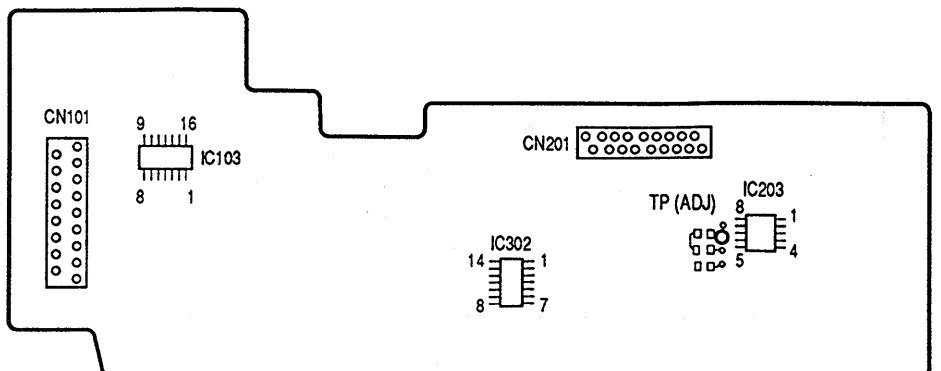

BLOCK DIAGRAM

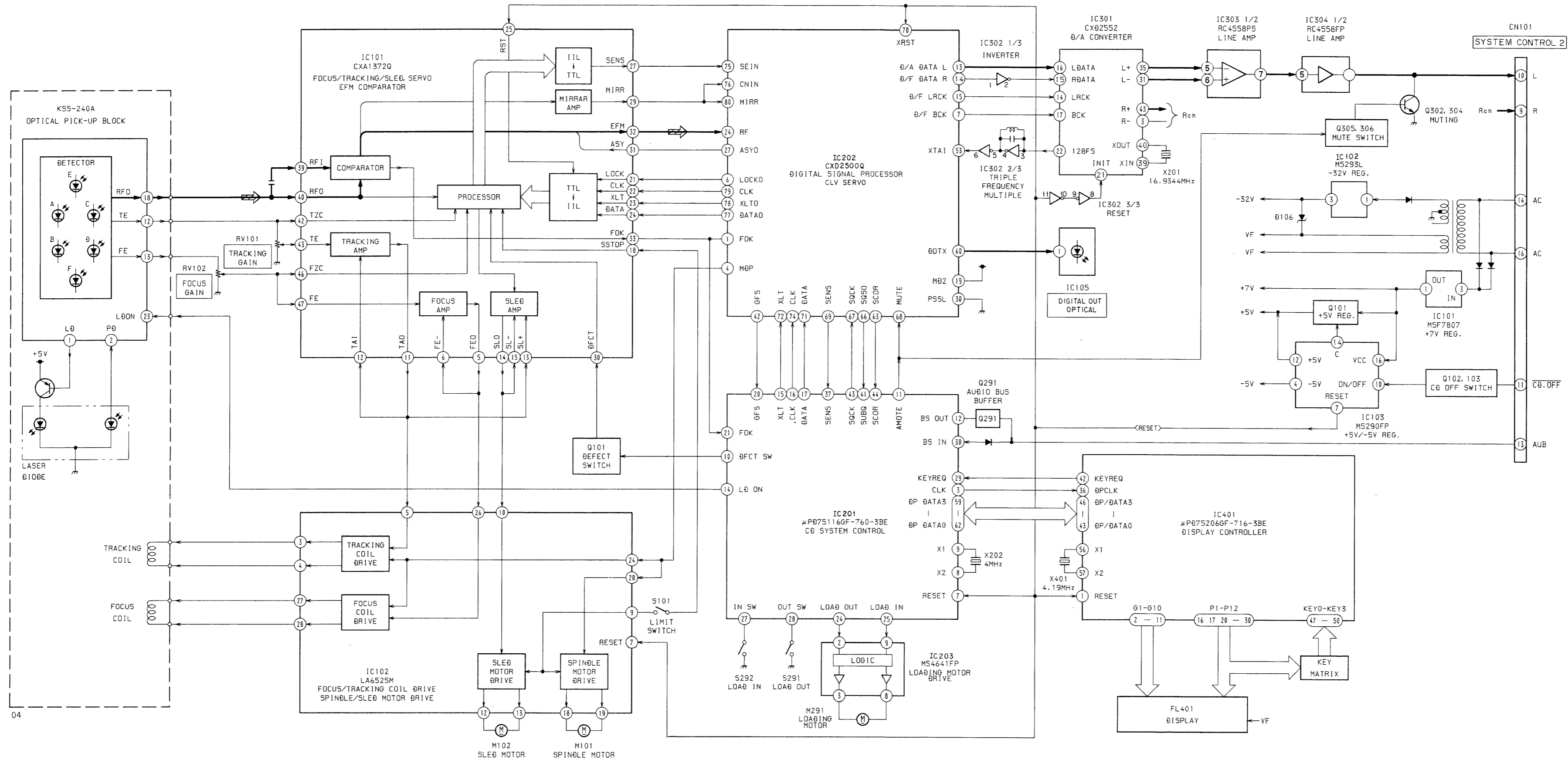

04

SEMICONDUCTOR LEAD LAYOUTS

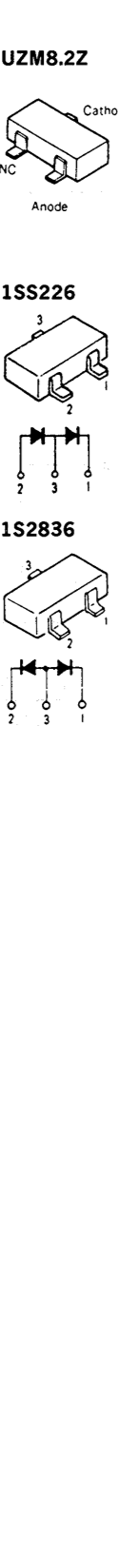
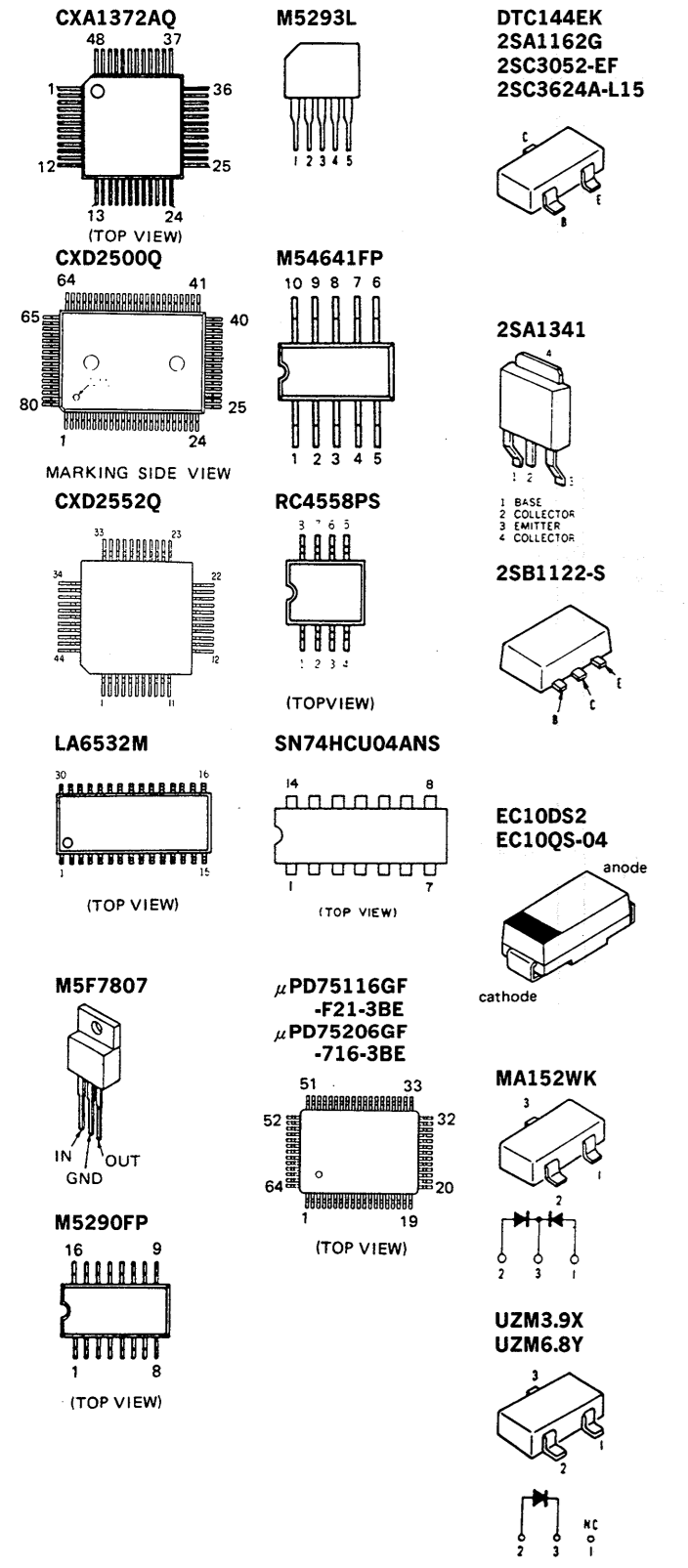

● Semiconductor Location EXCEPT BD BOARD

Ref. No.	Location
D101	B-10
D102	B-10
D103	C-11
D113	B-11
D131	B-10
D132	C-10
D201	G-9
D206	G-10
D301	D-9
D302	B-9
D401	D-17
D402	D-19
D403	D-15
IC101	C-6
IC102	B-2
IC103	C-10
IC105	B-5
IC201	G-7
IC202	F-7
IC203	G-9
IC301	E-7
IC302	E-9
IC303	C-7
IC304	C-7
IC401	D-15
Q101	C-9
Q102	B-9
Q103	B-10
Q201	G-9
Q301	C-9
Q302	B-9
Q303	C-9
Q304	B-9
Q305	B-9
Q306	B-9

BD BOARD

Ref. No.	Location
Q101	F-13
IC101	F-13
IC102	F-14

Note:
 ● : parts extracted from the component side.
 ○ : Through hole.
 ■ : Pattern on the side which is seen.
 ▨ : Pattern of the rear side.

PRINTED WIRING BOARDS

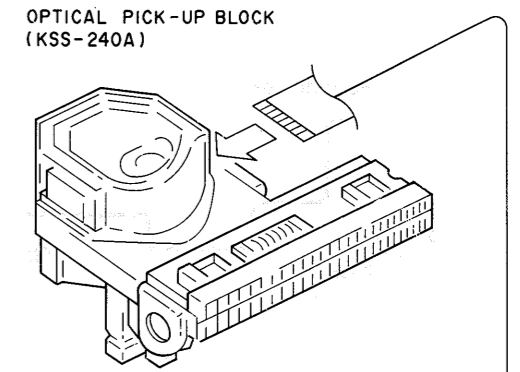
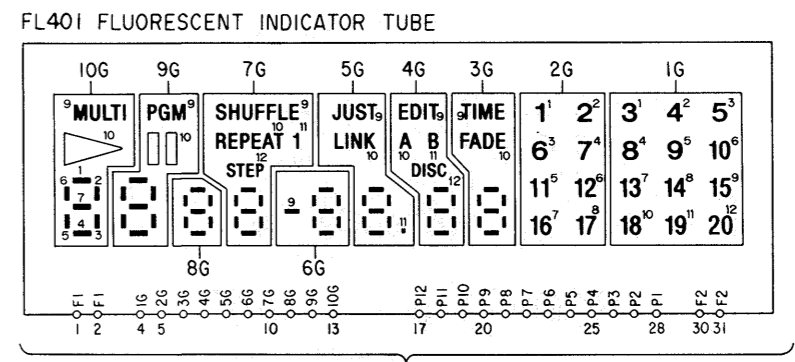
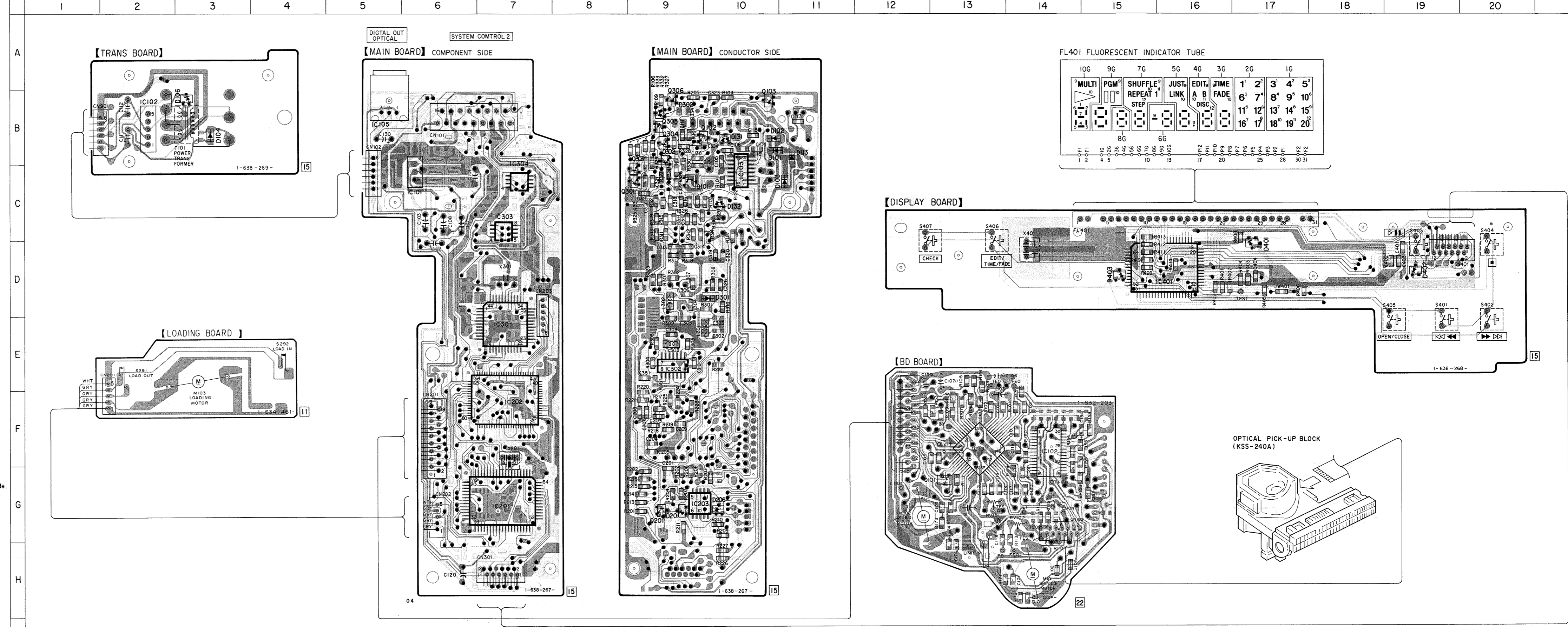

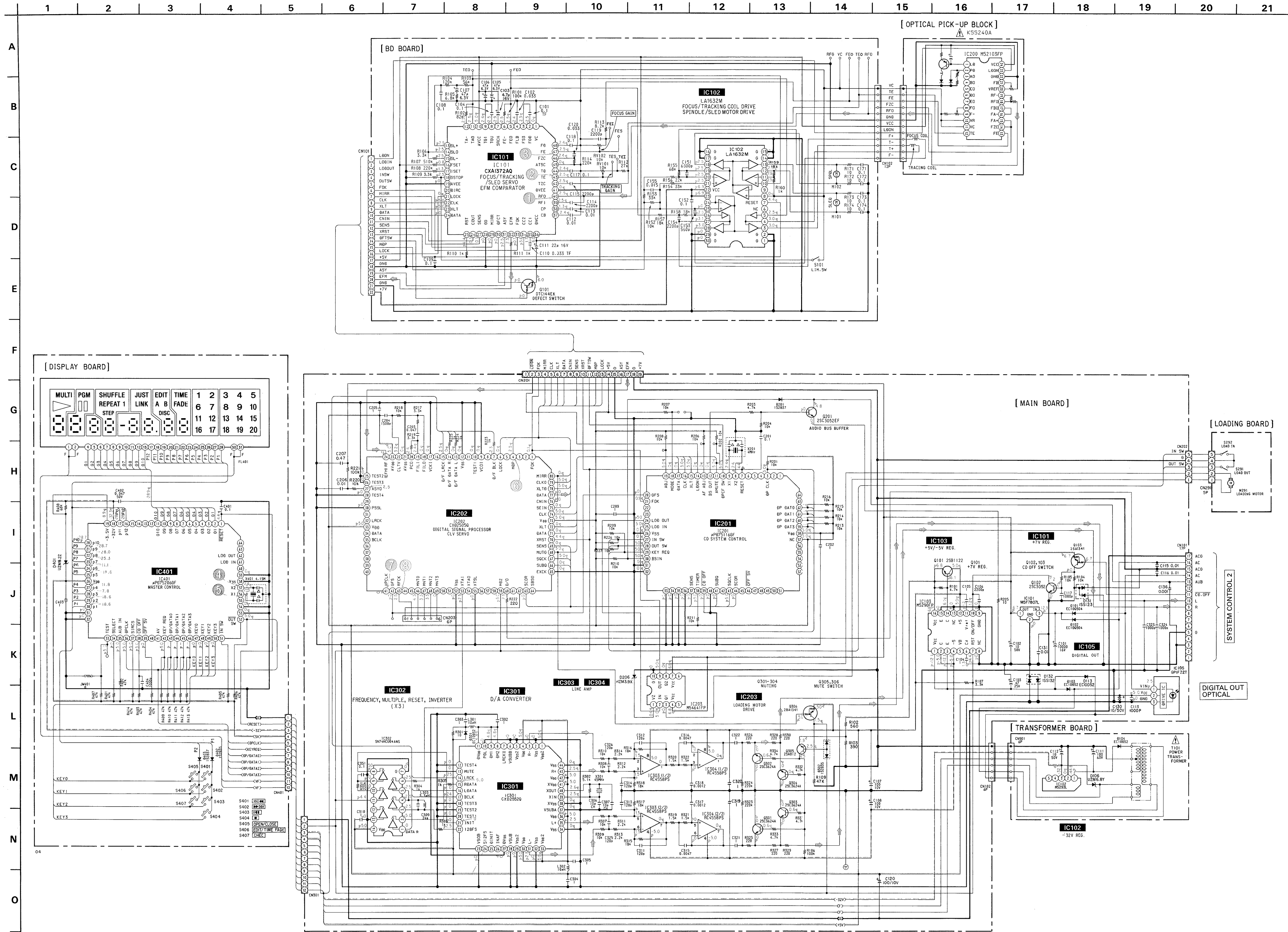

• Waveforms

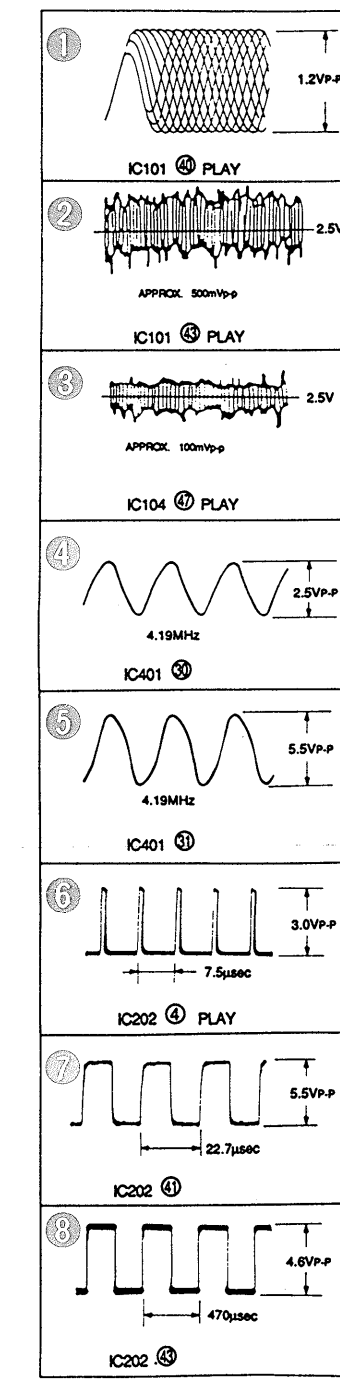

Note:
 • All capacitors are in μF unless otherwise noted. pF : μF 50WV or less are not indicated except for electrolytics and tantalums.
 • All resistors are in Ω and $1/4\text{W}$ or less unless otherwise specified.
 • Δ : internal component.
 Note: The components identified by mark Δ or dotted line with mark Δ are critical for safety. Replace only with part number specified.

- : B+ Line
- ◻ : B- Line
- : adjustment for repair.
- Voltage and waveforms are dc with respect to ground under no-signal conditions.
- Voltages are taken with a VOM (input Impedance 10M Ω). Voltage variations may be noted due to normal production tolerances.
- Waveforms are taken with an oscilloscope. Voltage variations may be noted due to normal production tolerances.
- Circled numbers refer to waveforms.
- Signal path.

• IC Block Diagrams

IC101 CXA1372AQ

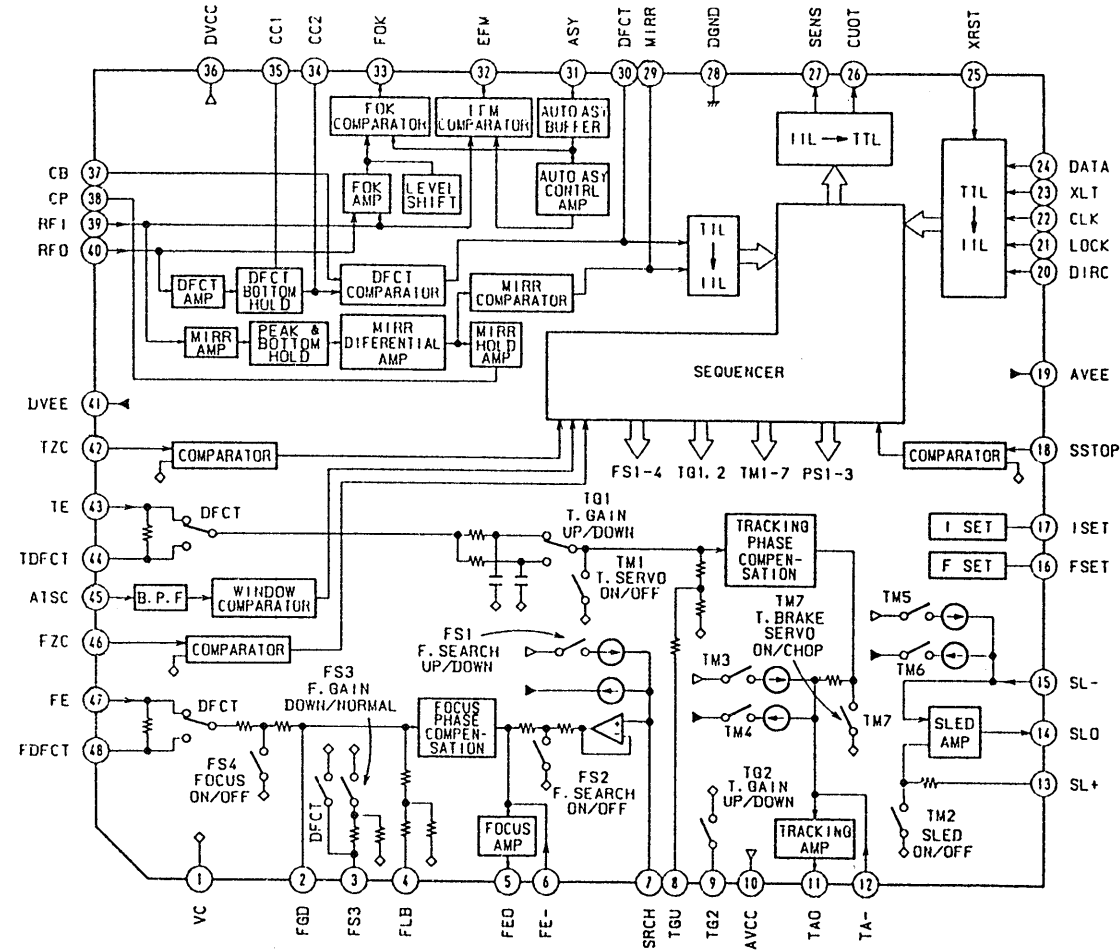

IC301 CXD2552Q

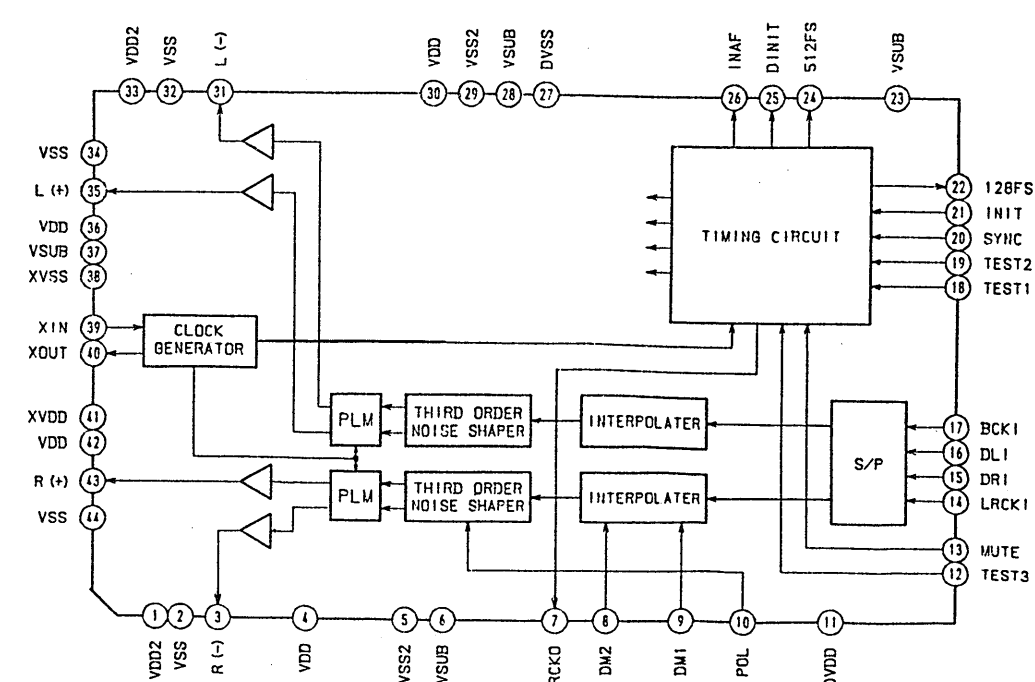

IC102 M5293L

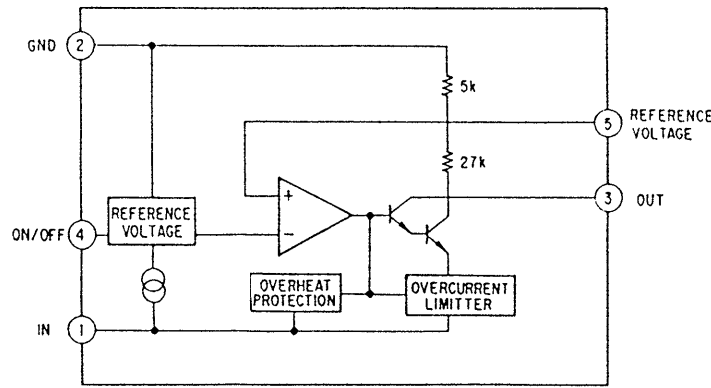

IC103 M5290FP

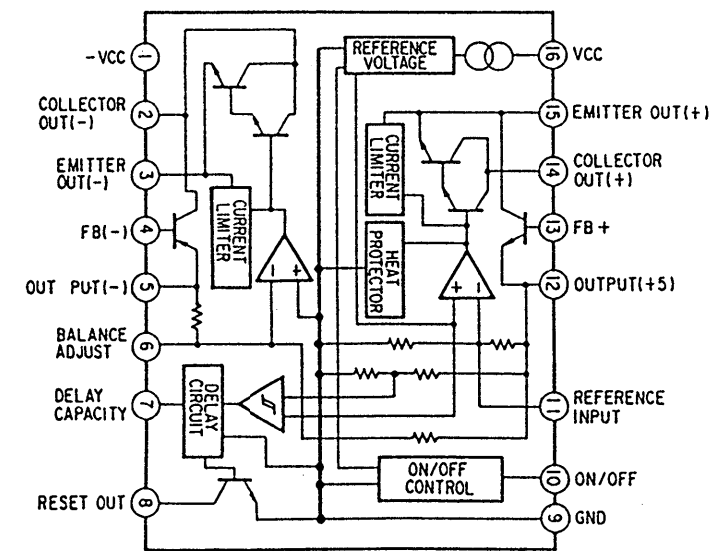

IC203 M54641FP

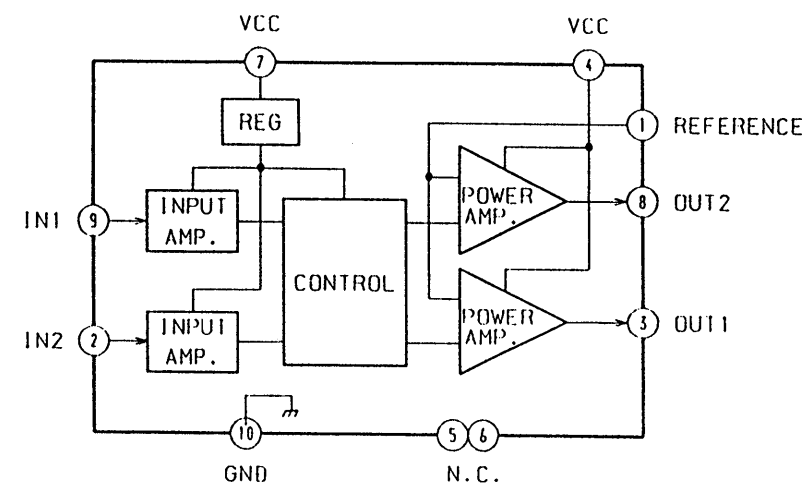

IC202 CXD2505Q

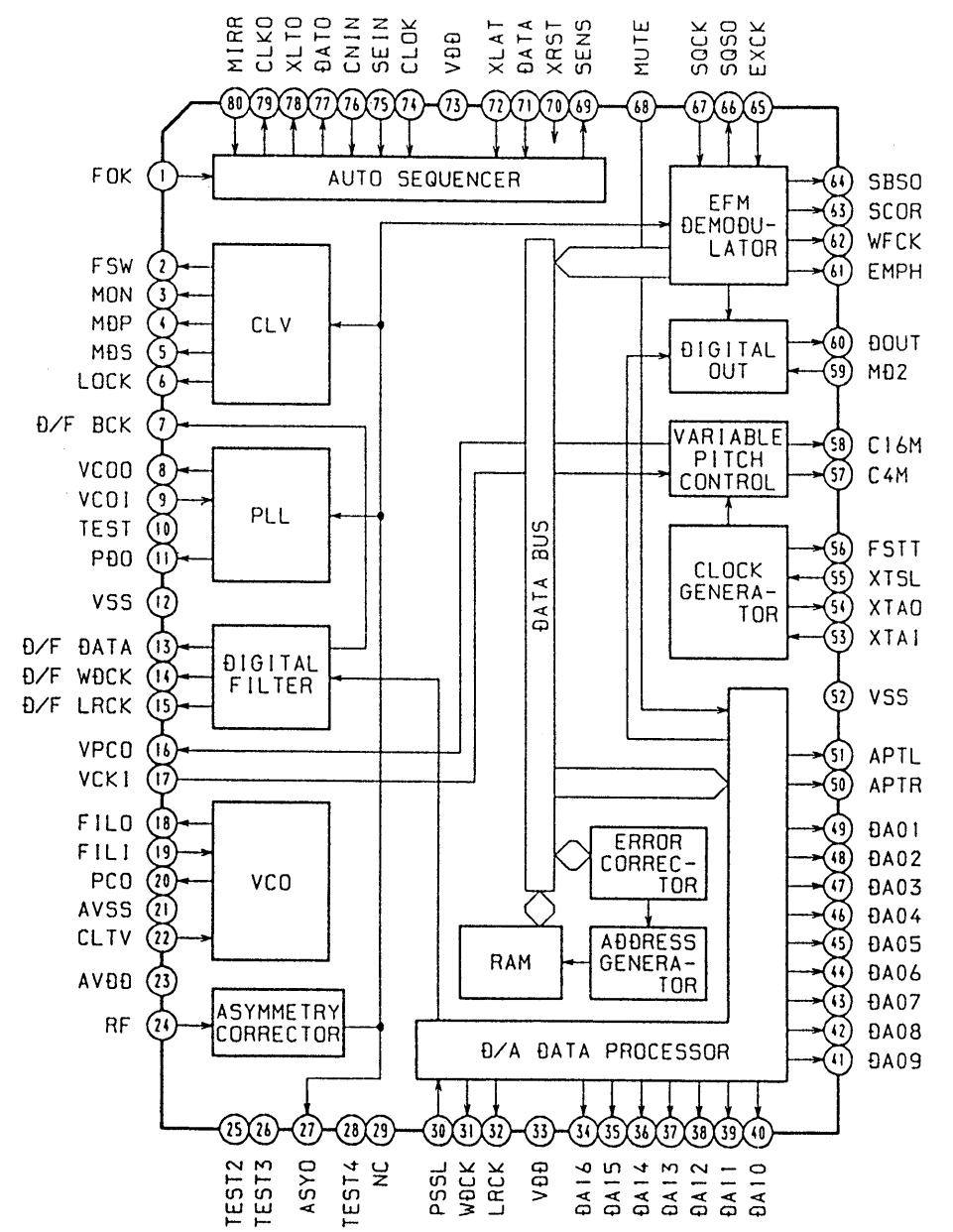

EXPLODED VIEW

The Difference between AEP Model and Germany Model.

Page	AEP model				Germany model			
	Ref. No.	Part No.	Description	Remark	Part No.	Description	Remark	
23	*7	4-948-753-11	PANEL (CDP), BACK		*4-948-753-21	PANEL (CDP), BACK		
	*10	A-4649-273-A	DISPLAY BOARD, COMPLETE		*A-4617-811-A	DISPLAY BOARD, COMPLETE		
	*11	A-4649-275-A	MAIN BOARD, COMPLETE		*A-4617-805-A	MAIN BOARD, COMPLETE		
	13	1-690-753-11	WIER (FLAT TYPE) (22 CORE)		1-535-845-11	JUMPER, FILM (WITH TERMINAL)		
	*14	1-642-542-11	POWER BOARD		*1-638-269-11	TRANSFORMER BOARD		
	IC105	8-749-923-04	IC TOTX178		8-749-921-12	IC GP1F32T		
	△T101	1-450-704-11	TRANSFORMER, POWER		△1-450-341-11	TRANSFORMER, POWER		

ELECTRICAL PARTS LIST

NOTE:

- Due to standardization, replacements in the parts list may be different from the parts specified in the diagrams or the components used on the set.
- -XX and -X mean standardized parts, so they may have some difference from the original one.
- RESISTORS
All resistors are in ohms.
METAL: Metal-film resistor.
METAL OXIDE: Metal oxide-film resistor.
F: nonflammable

- Items marked "*" are not stocked since they are seldom required for routine service. Some delay should be anticipated when ordering these items.
- SEMICONDUCTORS
In each case, u: μ , for example:
uA ..: μ A.. uPA..: μ PA..
uPB..: μ PB.. uPC..: μ PC.. uPD..: μ PD..
- CAPACITORS
uF: μ F
- COILS
uH: μ H

The components identified by mark Δ or dotted line with mark Δ are critical for safety. Replace only with part number specified.

When indicating parts by reference number, please include the board.

Ref. No.	Part No.	Description	Remark
*	A-4617-371-A	BD BOARD, COMPLETE *****	
		< CAPACITOR >	
C101	1-163-038-00	CERAMIC CHIP 0.1uF	25V
C102	1-163-989-11	CERAMIC CHIP 0.033uF	10% 25V
C103	1-126-163-11	ELECT 4.7uF	20% 50V
C104	1-163-038-00	CERAMIC CHIP 0.1uF	25V
C105	1-126-154-11	ELECT 47uF	20% 6.3V
C106	1-126-154-11	ELECT 47uF	20% 6.3V
C107	1-126-154-11	ELECT 47uF	20% 6.3V
C108	1-163-038-00	CERAMIC CHIP 0.1uF	25V
C109	1-163-038-00	CERAMIC CHIP 0.1uF	25V
C110	1-163-989-11	CERAMIC CHIP 0.033uF	10% 25V
C111	1-131-367-00	TANTALUM 22uF	10% 20V
C112	1-164-232-11	CERAMIC CHIP 0.01uF	50V
C113	1-164-232-11	CERAMIC CHIP 0.01uF	50V
C114	1-164-161-11	CERAMIC CHIP 0.0022uF	10% 100V
C115	1-164-161-11	CERAMIC CHIP 0.0022uF	10% 100V
C117	1-163-038-00	CERAMIC CHIP 0.1uF	25V
C118	1-163-038-00	CERAMIC CHIP 0.1uF	25V
C119	1-164-161-11	CERAMIC CHIP 0.0022uF	10% 100V
C120	1-163-989-11	CERAMIC CHIP 0.033uF	10% 25V
C151	1-163-019-00	CERAMIC CHIP 0.0068uF	10% 50V
C152	1-163-038-00	CERAMIC CHIP 0.1uF	25V
C153	1-163-006-11	CERAMIC CHIP 560PF	10% 50V
C154	1-164-161-11	CERAMIC CHIP 0.0022uF	10% 100V
C155	1-163-023-00	CERAMIC CHIP 0.015uF	5% 50V
C171	1-163-038-00	CERAMIC CHIP 0.1uF	25V
C172	1-163-038-00	CERAMIC CHIP 0.1uF	25V
C173	1-163-038-00	CERAMIC CHIP 0.1uF	25V
C174	1-163-038-00	CERAMIC CHIP 0.1uF	25V
		< CONNECTOR >	
CN101	1-568-796-11	SOCKET, CONNECTOR 22P	
CN102	1-568-795-11	SOCKET, CONNECTOR 12P	

Ref. No.	Part No.	Description	Remark
		< IC >	
IC101	8-752-053-73	IC CXA1372AQ	
IC102	8-759-822-36	IC LA6532M	
		< JUMPER RESISTOR >	
J101	1-216-295-00	METAL CHIP 0	5% 1/10W
J102	1-216-295-00	METAL CHIP 0	5% 1/10W
		< TRANSISTOR >	
Q101	8-729-901-01	TRANSISTOR DTC144EK	
		< RESISTOR >	
R101	1-216-097-00	METAL CHIP 100K	5% 1/10W
R102	1-216-095-00	METAL CHIP 82K	5% 1/10W
R103	1-216-091-00	METAL CHIP 56K	5% 1/10W
R104	1-216-099-00	METAL CHIP 120K	5% 1/10W
R105	1-216-069-00	METAL CHIP 6.8K	5% 1/10W
R106	1-216-061-00	METAL CHIP 3.3K	5% 1/10W
R107	1-216-114-00	METAL GLAZE 510K	5% 1/10W
R108	1-216-105-00	METAL CHIP 220K	5% 1/10W
R109	1-216-061-00	METAL CHIP 3.3K	5% 1/10W
R110	1-216-049-00	METAL CHIP 1K	5% 1/10W
R111	1-216-049-00	METAL CHIP 1K	5% 1/10W
R112	1-216-083-00	METAL CHIP 27K	5% 1/10W
R113	1-216-071-00	METAL CHIP 8.2K	5% 1/10W
R114	1-216-105-00	METAL CHIP 220K	5% 1/10W
R152	1-216-073-00	METAL CHIP 10K	5% 1/10W
R153	1-216-085-00	METAL CHIP 33K	5% 1/10W
R154	1-216-085-00	METAL CHIP 33K	5% 1/10W
R155	1-216-093-00	METAL CHIP 68K	5% 1/10W
R156	1-216-081-00	METAL CHIP 22K	5% 1/10W
R157	1-216-079-00	METAL CHIP 18K	5% 1/10W
R158	1-216-079-00	METAL CHIP 18K	5% 1/10W
R159	1-216-079-00	METAL CHIP 18K	5% 1/10W
R160	1-216-049-00	METAL CHIP 1K	5% 1/10W
R171	1-216-001-00	METAL CHIP 10	5% 1/10W
R172	1-216-001-00	METAL CHIP 10	5% 1/10W

BD

DISPLAY

MAIN

TRANSFORMER

Ref. No.	Part No.	Description	Remark		
R173	1-216-001-00	METAL CHIP	10	5%	1/10W
R174	1-216-001-00	METAL CHIP	10	5%	1/10W
< VARIABLE RESISTOR >					
RV101	1-241-630-11	RES, ADJ, CARBON 10K			
RV102	1-241-630-11	RES, ADJ, CARBON 10K			
< SWITCH >					
S101	1-572-085-11	SWITCH, LEAF (LIMIT)			

*	A-4617-811-A	DISPLAY BOARD, COMPLETE			

*	A-4617-805-A	MAIN BOARD, COMPLETE			

*	1-638-269-11	TRANSFORMER BOARD			

*	1-560-242-21	BUS BAR 4P			
*	4-880-403-11	HEAT SINK			
*	4-932-810-11	CUSHION (FL)			
	4-946-509-01	SPACER			
	7-682-548-04	SCREW +BVTT 3X8 (S)			
< CAPACITOR >					
C101	1-126-939-11	ELECT	10000uF	20%	16V
C102	1-124-907-11	ELECT	10uF	20%	50V
C103	1-124-477-11	ELECT	47uF	20%	25V
C104	1-164-346-11	CERAMIC CHIP	1uF		16V
C105	1-164-346-11	CERAMIC CHIP	1uF		16V
C106	1-164-161-11	CERAMIC CHIP	0.0022uF	10%	100V
C107	1-124-443-00	ELECT	100uF	20%	10V
C108	1-124-443-00	ELECT	100uF	20%	10V
C111	1-126-063-11	ELECT	100uF	20%	63V
C112	1-124-907-11	ELECT	10uF	20%	50V
C113	1-163-009-11	CERAMIC CHIP	0.001uF	10%	50V
C115	1-163-031-11	CERAMIC CHIP	0.01uF		50V
C116	1-163-031-11	CERAMIC CHIP	0.01uF		50V
C117	1-163-009-11	CERAMIC CHIP	0.001uF	10%	50V
C120	1-124-443-00	ELECT	100uF	20%	10V
C130	1-124-907-11	ELECT	10uF	20%	50V
C131	1-163-031-11	CERAMIC CHIP	0.01uF		50V
C136	1-163-009-11	CERAMIC CHIP	0.001uF	10%	50V
C201	1-163-038-00	CERAMIC CHIP	0.1uF		25V
C202	1-164-346-11	CERAMIC CHIP	1uF		16V
C203	1-163-035-00	CERAMIC CHIP	0.047uF		50V
C204	1-163-011-11	CERAMIC CHIP	0.0015uF	10%	50V
C205	1-164-346-11	CERAMIC CHIP	1uF		16V
C206	1-163-031-11	CERAMIC CHIP	0.01uF		50V
C207	1-164-005-11	CERAMIC CHIP	0.47uF		25V

Ref. No.	Part No.	Description	Remark		
C209	1-164-346-11	CERAMIC CHIP	1uF		16V
C302	1-164-346-11	CERAMIC CHIP	1uF		16V
C303	1-164-346-11	CERAMIC CHIP	1uF		16V
C304	1-164-346-11	CERAMIC CHIP	1uF		16V
C305	1-164-346-11	CERAMIC CHIP	1uF		16V
C306	1-163-227-11	CERAMIC CHIP	10PF	5%	50V
C307	1-163-227-11	CERAMIC CHIP	10PF	5%	50V
C309	1-163-102-00	CERAMIC CHIP	24PF	5%	50V
C310	1-164-346-11	CERAMIC CHIP	1uF		16V
C311	1-163-119-00	CERAMIC CHIP	120PF	5%	50V
C312	1-163-119-00	CERAMIC CHIP	120PF	5%	50V
C313	1-163-119-00	CERAMIC CHIP	120PF	5%	50V
C314	1-163-119-00	CERAMIC CHIP	120PF	5%	50V
C315	1-163-017-00	CERAMIC CHIP	0.0047uF	5%	50V
C316	1-163-017-00	CERAMIC CHIP	0.0047uF	5%	50V
C317	1-163-010-11	CERAMIC CHIP	0.0012uF	10%	50V
C318	1-163-010-11	CERAMIC CHIP	0.0012uF	10%	50V
C319	1-164-346-11	CERAMIC CHIP	1uF		16V
C320	1-164-346-11	CERAMIC CHIP	1uF		16V
C321	1-164-346-11	CERAMIC CHIP	1uF		16V
C322	1-164-346-11	CERAMIC CHIP	1uF		16V
C323	1-163-009-11	CERAMIC CHIP	0.001uF	10%	50V
C324	1-163-009-11	CERAMIC CHIP	0.001uF	10%	50V
C325	1-163-119-00	CERAMIC CHIP	120PF	5%	50V
C326	1-163-119-00	CERAMIC CHIP	120PF	5%	50V
C351	1-163-038-00	CERAMIC CHIP	0.1uF		25V
C401	1-163-038-00	CERAMIC CHIP	0.1uF		25V
C402	1-163-035-00	CERAMIC CHIP	0.047uF		50V
C403	1-164-346-11	CERAMIC CHIP	1uF		16V
C404	1-163-009-11	CERAMIC CHIP	0.001uF	10%	50V
< CONNECTOR >					
* CN101	1-569-624-11	SOCKET, CONNECTOR 17P (SYSTEM CONTROL 2)			
CN102	1-568-662-11	CONNECTOR, BOARD TO BOARD 6P			
CN201	1-568-802-11	SOCKET, CONNECTOR 19P			
* CN202	1-564-339-00	PIN, CONNECTOR 5P			
* CN203	1-564-340-00	PIN, CONNECTOR 6P			
* CN301	1-573-099-11	HOUSING, CONNECTOR 12P			
* CN401	1-573-098-11	HOUSING, CONNECTOR 12P			
CN901	1-568-668-11	CONNECTOR, BOARD TO BOARD 6P			
< DIODE >					
D101	8-719-210-39	DIODE	EC10QS-04		
D102	8-719-210-39	DIODE	EC10QS-04		
D103	8-719-210-33	DIODE	EC10DS2		
D104	8-719-210-33	DIODE	EC10DS2		
D106	8-719-021-59	DIODE	UZM6.8Y		
D113	8-719-210-33	DIODE	EC10DS2		
D131	8-719-800-76	DIODE	1SS226		

DISPLAY

MAIN

TRANSFORMER

Ref. No.	Part No.	Description	Remark	Ref. No.	Part No.	Description	Remark
D132	8-719-800-76	DIODE 1SS226				< RESISTOR >	
D201	8-719-400-18	DIODE MA152WK		R101	1-216-065-00	METAL CHIP 4.7K 5%	1/10W
D206	8-719-021-11	DIODE UZM3.9X		R102	1-216-043-00	METAL CHIP 560 5%	1/10W
D301	8-719-210-33	DIODE EC10DS2		R103	1-216-039-00	METAL CHIP 390 5%	1/10W
D302	8-719-104-34	DIODE 1S2836		R104	1-216-073-00	METAL CHIP 10K 5%	1/10W
D401	8-719-021-77	DIODE UZM8.2Z		R105	1-216-073-00	METAL CHIP 10K 5%	1/10W
D402	8-719-104-34	DIODE 1S2836		R106	1-216-097-00	METAL CHIP 100K 5%	1/10W
D403	8-719-400-18	DIODE MA152WK		R107	1-216-061-00	METAL CHIP 3.3K 5%	1/10W
		< FLUORESCENT INDICATOR >		R109	1-216-089-00	METAL CHIP 47K 5%	1/10W
FL401	1-519-652-11	INDICATOR TUBE, FLUORESCENT		R201	1-216-073-00	METAL CHIP 10K 5%	1/10W
		< IC >		R202	1-216-073-00	METAL CHIP 10K 5%	1/10W
IC101	8-759-604-86	IC M5F7807		R203	1-216-065-00	METAL CHIP 4.7K 5%	1/10W
IC102	8-759-633-42	IC M5293L		R204	1-216-073-00	METAL CHIP 10K 5%	1/10W
IC103	8-759-636-24	IC M5290FP		R205	1-216-001-00	METAL CHIP 10 5%	1/10W
IC105	8-749-921-12	IC GP1F32T		R206	1-216-073-00	METAL CHIP 10K 5%	1/10W
IC201	8-759-059-86	IC uPD75116GF-F21-3BE		R207	1-216-073-00	METAL CHIP 10K 5%	1/10W
IC202	8-752-340-37	IC CXD2505Q		R208	1-216-073-00	METAL CHIP 10K 5%	1/10W
IC203	8-759-636-20	IC M54641FP		R209	1-216-073-00	METAL CHIP 10K 5%	1/10W
IC301	8-752-334-87	IC CXD2552Q		R210	1-216-073-00	METAL CHIP 10K 5%	1/10W
IC302	8-759-927-29	IC SN74HCU04ANS		R211	1-216-073-00	METAL CHIP 10K 5%	1/10W
IC303	8-759-996-43	IC RC4558PS		R213	1-216-073-00	METAL CHIP 10K 5%	1/10W
IC304	8-759-996-43	IC RC4558PS		R214	1-216-073-00	METAL CHIP 10K 5%	1/10W
IC401	8-759-154-14	IC uPD75206GF-716-3BE		R215	1-216-073-00	METAL CHIP 10K 5%	1/10W
		< JUMPER RESISTOR >		R216	1-216-073-00	METAL CHIP 10K 5%	1/10W
JW401	1-216-295-00	METAL CHIP 0 5%	1/10W	R217	1-216-061-00	METAL CHIP 3.3K 5%	1/10W
		< COIL >		R218	1-216-073-00	METAL CHIP 10K 5%	1/10W
L301	1-410-381-11	INDUCTOR CHIP 10uH		R219	1-216-061-00	METAL CHIP 3.3K 5%	1/10W
L302	1-410-381-11	INDUCTOR CHIP 10uH		R220	1-216-073-00	METAL CHIP 10K 5%	1/10W
L303	1-410-375-11	INDUCTOR CHIP 3.3uH		R221	1-216-097-00	METAL CHIP 100K 5%	1/10W
		< TRANSISTOR >		R222	1-216-033-00	METAL CHIP 220 5%	1/10W
Q101	8-729-804-41	TRANSISTOR 2SB1122-S		R223	1-216-049-00	METAL CHIP 1K 5%	1/10W
Q102	8-729-620-06	TRANSISTOR 2SC3052-EF		R224	1-216-049-00	METAL CHIP 1K 5%	1/10W
Q103	8-729-805-69	TRANSISTOR 2SA1341		R225	1-216-049-00	METAL CHIP 1K 5%	1/10W
Q201	8-729-620-06	TRANSISTOR 2SC3052-EF		R226	1-216-073-00	METAL CHIP 10K 5%	1/10W
Q301	8-729-107-46	TRANSISTOR 2SC3624A-L15		R227	1-216-073-00	METAL CHIP 10K 5%	1/10W
Q302	8-729-107-46	TRANSISTOR 2SC3624A-L15		R301	1-216-001-00	METAL CHIP 10 5%	1/10W
Q303	8-729-107-46	TRANSISTOR 2SC3624A-L15		R302	1-216-066-00	METAL CHIP 5.1K 5%	1/10W
Q304	8-729-107-46	TRANSISTOR 2SC3624A-L15		R303	1-216-049-00	METAL CHIP 1K 5%	1/10W
Q305	8-729-216-22	TRANSISTOR 2SA1162-G		R304	1-216-049-00	METAL CHIP 1K 5%	1/10W
Q306	8-729-805-69	TRANSISTOR 2SA1341		R305	1-216-049-00	METAL CHIP 1K 5%	1/10W
				R307	1-216-073-00	METAL CHIP 10K 5%	1/10W
				R308	1-216-073-00	METAL CHIP 10K 5%	1/10W
				R309	1-216-073-00	METAL CHIP 10K 5%	1/10W
				R310	1-216-073-00	METAL CHIP 10K 5%	1/10W
				R311	1-216-057-00	METAL CHIP 2.2K 5%	1/10W
				R312	1-216-057-00	METAL CHIP 2.2K 5%	1/10W
				R313	1-216-057-00	METAL CHIP 2.2K 5%	1/10W
				R314	1-216-057-00	METAL CHIP 2.2K 5%	1/10W

DISPLAY

MAIN

TRANSFORMER

LOADING

Ref. No.	Part No.	Description	Remark
R315	1-216-079-00	METAL CHIP	18K 5% 1/10W
R316	1-216-079-00	METAL CHIP	18K 5% 1/10W
R317	1-216-079-00	METAL CHIP	18K 5% 1/10W
R318	1-216-079-00	METAL CHIP	18K 5% 1/10W
R319	1-216-053-00	METAL CHIP	1.5K 5% 1/10W
R320	1-216-053-00	METAL CHIP	1.5K 5% 1/10W
R321	1-216-053-00	METAL CHIP	1.5K 5% 1/10W
R322	1-216-053-00	METAL CHIP	1.5K 5% 1/10W
R323	1-216-105-00	METAL CHIP	220K 5% 1/10W
R324	1-216-105-00	METAL CHIP	220K 5% 1/10W
R325	1-216-033-00	METAL CHIP	220 5% 1/10W
R326	1-216-033-00	METAL CHIP	220 5% 1/10W
R327	1-216-033-00	METAL CHIP	220 5% 1/10W
R328	1-216-033-00	METAL CHIP	220 5% 1/10W
R329	1-216-033-00	METAL CHIP	220 5% 1/10W
R330	1-216-033-00	METAL CHIP	220 5% 1/10W
R331	1-216-065-00	METAL CHIP	4.7K 5% 1/10W
R332	1-216-065-00	METAL CHIP	4.7K 5% 1/10W
R333	1-216-065-00	METAL CHIP	4.7K 5% 1/10W
R334	1-216-065-00	METAL CHIP	4.7K 5% 1/10W
R351	1-216-105-00	METAL CHIP	220K 5% 1/10W
R401	1-216-089-00	METAL CHIP	47K 5% 1/10W
R402	1-216-089-00	METAL CHIP	47K 5% 1/10W
R403	1-216-089-00	METAL CHIP	47K 5% 1/10W
R404	1-216-089-00	METAL CHIP	47K 5% 1/10W
R405	1-216-089-00	METAL CHIP	47K 5% 1/10W
R406	1-216-089-00	METAL CHIP	47K 5% 1/10W
R407	1-216-089-00	METAL CHIP	47K 5% 1/10W
R408	1-216-093-00	METAL CHIP	68K 5% 1/10W
R409	1-216-089-00	METAL CHIP	47K 5% 1/10W
R410	1-216-089-00	METAL CHIP	47K 5% 1/10W
R411	1-216-089-00	METAL CHIP	47K 5% 1/10W
R412	1-216-089-00	METAL CHIP	47K 5% 1/10W
R413	1-216-089-00	METAL CHIP	47K 5% 1/10W
R414	1-216-089-00	METAL CHIP	47K 5% 1/10W
< SWITCH >			
S401	1-572-184-11	SWITCH, KEYBOARD (◀▶)	
S402	1-572-184-11	SWITCH, KEYBOARD (▶▶)	
S403	1-572-184-11	SWITCH, KEYBOARD (▷)	
S404	1-572-184-11	SWITCH, KEYBOARD (■)	
S405	1-572-184-11	SWITCH, KEYBOARD (OPEN/CLOSE)	
S406	1-572-184-11	SWITCH, KEYBOARD (EDIT/TIME FADE)	
S407	1-572-184-11	SWITCH, KEYBOARD (CHECK)	
< TRANSFORMER >			
△T101	1-450-341-11	TRANSFORMER, POWER	

Ref. No.	Part No.	Description	Remark
< VIBRATOR >			
X201	1-577-358-21	VIBRATOR, CERAMIC (4MHz)	
X301	1-577-686-11	VIBRATOR, CRYSTAL (45MHz)	
X401	1-577-359-21	VIBRATOR, CERAMIC (4.19MHz)	

*	1-634-461-11	LOADING BOARD	

< CONNECTOR >			
* CN291	1-564-498-11	PIN, CONNECTOR 5P	
< SWITCH >			
S291	1-571-924-11	SWITCH, LEAF (LOAD OUT)	
S292	1-571-924-11	SWITCH, LEAF (LOAD IN)	

MISCELLANEOUS			

12	1-575-001-11	WIRE, FLAT TYPE (12 CORE)	
13	1-535-845-11	JUMPER, FILM (WITH TERMINAL)	
16	1-575-001-11	WIRE, FLAT TYPE (12 CORE)	
△105	8-848-144-11	DEVICE, OPTICAL KSS-240A	
M101	X-4917-523-3	MOTOR ASSY, SPINDLE	
M102	X-4917-504-1	MOTOR ASSY, SLED	
M291	A-4608-362-A	MOTOR (L) ASSY	

The components identified by
mark △ or dotted line with mark.
△ are critical for safety.
Replace only with part number
specified.

