

6 Connection Diagram, LQFP-48

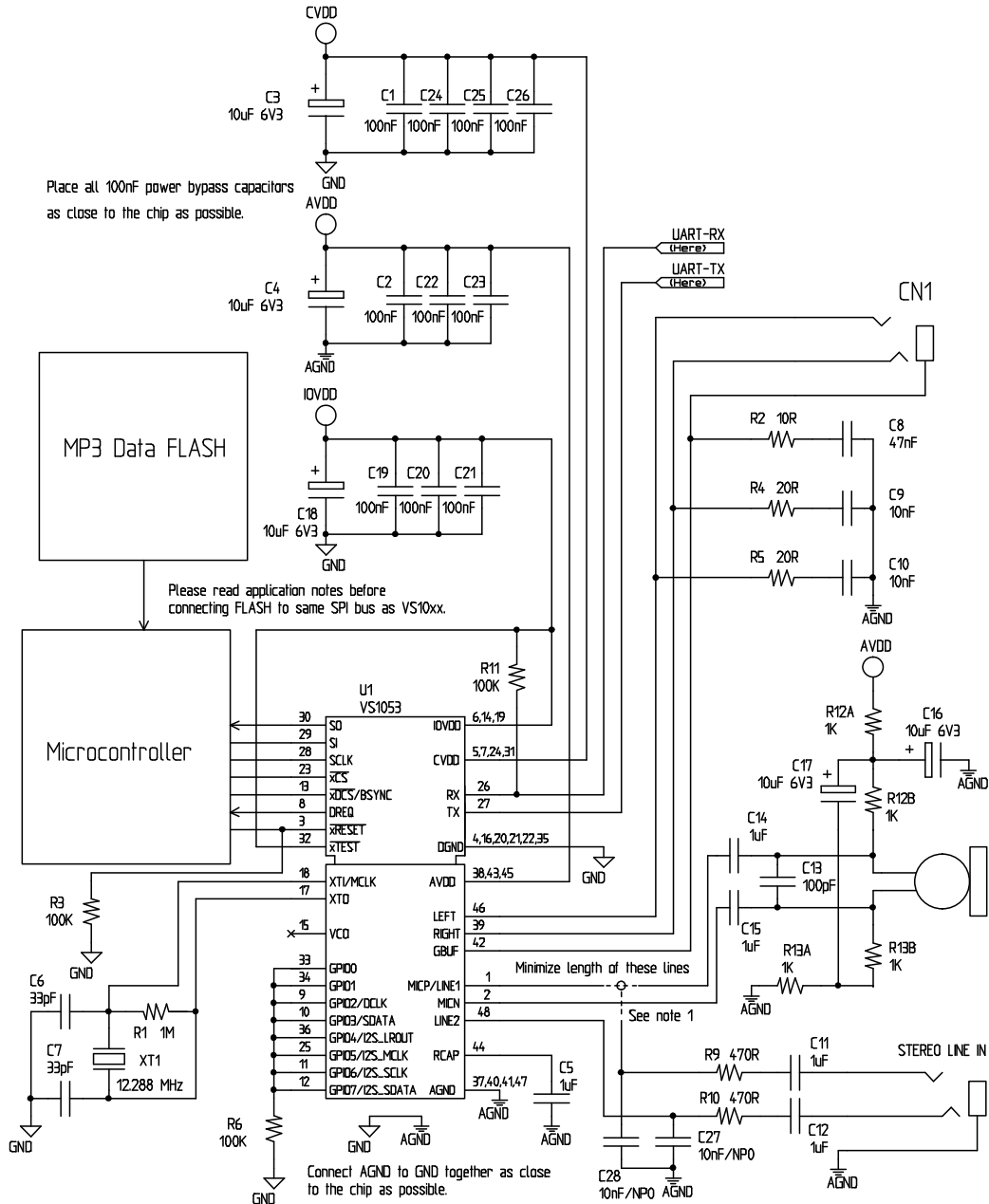

Figure 3: Typical Connection Diagram Using LQFP-48.

Figure 3 shows a typical connection diagram for VS1053.

Figure Note 1: Connect either Microphone In or Line In, but not both at the same time.

Note: This connection assumes SM_SDINew is active (see Chapter 8.7.1). If also SM_SDISHARE is used, xDCS should be tied low or high (see Chapter 7.2.1).