

## TOUCH CONTROL HALOGEN LAMP DIMMER

November 2002

### FEATURES:

- Touch or pushbutton control of incandescent lamps and transformer-coupled halogen lamps
- Transformer can be Magnetic or Electronic
- Direct replacement for P/N SLB 0587
- Automatic safety shutdown
- PLL synchronization allows use as a Wall Switch
- Three operating modes
- Extension input for remote activation
- 50Hz/60Hz AC line frequency
- +5V Power Supply ( $V_{DD}$  -  $V_{SS}$ )
- LS7631, LS7632 (DIP); LS7631-S, LS7632-S (SOIC)

### APPLICATIONS:

Electronic dimmers for wall switch control of ceiling mounted lighting, foot switch control of large floor lamps and hand switch control of table lamps.

### BACKGROUND AND GENERAL DESCRIPTION:

A typical electronic dimmer may not operate properly with the inductive load encountered when driving a transformer-coupled low-voltage halogen lamp. The inductive load can cause a phenomenon called half-waving, wherein the triac fires in alternate half-cycles only, which may lead to the thermal destruction of the load transformer. The problems encountered in driving an inductive load are addressed by the LS7631/LS7632 CMOS ICs as follows:

#### 1. Compensation for delayed triac cut-off.

When a trigger pulse is due to occur at a conduction angle which coincides with the on-state of the triac, the trigger pulse is delayed until the triac has turned off. This eliminates the underlying cause of half-waving.

#### 2. Compensation for delayed triac turn-on.

At the set conduction angle, a triac trigger pulse of 130.2 $\mu$ s (60 Hz) is issued by the IC. If the triac fails to fire, a second trigger pulse of 260.4 $\mu$ s width is issued 1ms later as a second attempt to fire the triac during the same half-cycle.

#### 3. Safety-shutdown.

If the frequency of occurrences of the delayed cut-off and delayed turn-on exceeds a preset threshold, a shutdown is initiated by turning off the triac trigger pulses. The safety-shutdown threshold value is accumulated in a 4-bit Up/Down counter. The count increments for every occurrence of delayed cut-off or delayed turn-on and decrements once every 8 SYNC pulses (AC line cycles). The counter will not decrement below zero. If the count reaches 15, the safety-shut-down is effected.

### PIN ASSIGNMENT - TOP VIEW

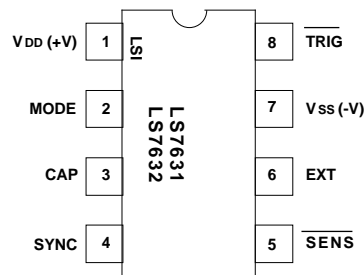

FIGURE 1

### INPUT/OUTPUT DESCRIPTION:

**$V_{DD}$**  (Pin 1) Supply voltage positive terminal.

**$V_{SS}$**  (Pin 7) Supply voltage negative terminal.

**MODE** (Pin 2) - See Table 1

Both LS7631 and LS7632 can operate in 3 different modes. The 3-state MODE input selects the operating modes:  $V_{SS}$  = Mode 0; Float = Mode 1;  $V_{DD}$  = Mode 2

**CAP** (Pin 3) - PLL filter capacitor input. See Figure 6.

**SYNC** (Pin 4) - See Figure 6

The AC line frequency is applied to this input. All internal timings are synchronized to the AC phase through a PLL circuit. The Load On/Off status information is also derived from this input.

**$\overline{SENS}$**  (Pin 5) - See Table 1

A Logic 0 applied to this input alters the  $\overline{TRIG}$  output either by turning it on, turning it off or by changing its conduction angle. Specifically which action takes place is dependent on the type of activation of the  $\overline{SENS}$  input, namely SHORT or LONG touch and the prior state of  $\overline{TRIG}$  output.

**EXT** (Pin 6)

Same functionality as the  $\overline{SENS}$  input, except that a Logic 1 is the active level at this input. EXT input is intended to be operated from a remote site with long cable connection, when noise can be expected. The sampling method used at this input makes it less sensitive to noise.

**$\overline{TRIG}$**  (Pin 8)

The  $\overline{TRIG}$  output is a low level pulse occurring once every half-cycle of the AC and is intended to drive the gate of a triac in series with the load. The conduction angle,  $\phi$ , of the  $\overline{TRIG}$  pulse can be varied by means of LONG and SHORT touches at either the  $\overline{SENS}$  or the EXT input.

The functional differences between LS7631 and LS7632 are:

**LS7631** - When a LONG touch is applied, the dimming direction automatically reverses whenever maximum or minimum conduction angles are reached.

**LS7632** - When a LONG touch is applied, the dimming stops whenever maximum or minimum conduction angles are reached. In order to change dimming levels from maximum or minimum, LONG touch must be removed and reapplied. The purpose of this feature is to allow the user to positively locate maximum and minimum conduction angles.

**LS7632 NOTE:** If the User applies a LONG Touch when the TRIG Conduction Angle is within a “few” degrees of Maximum or Minimum, the TRIG Conduction Angle can move to Maximum or Minimum and stop without the User being able to observe a change in brightness. Therefore, the User should be instructed that if no change in brightness is observed in response to a LONG Touch, the LONG Touch should be removed and reapplied in order to produce a change in brightness.

**TABLE 1**

MODE	SHORT TOUCH		LONG TOUCH		DIMMING REVERSAL (Note 5)
	PRE-TOUCH $\emptyset$	POST-TOUCH $\emptyset$	PRE-TOUCH $\emptyset$	POST-TOUCH $\emptyset$	
0	OFF	MAX(Note 1)	OFF/MIN	Varies up from MIN	N/A
	ON	OFF	MAX	Varies down from MAX	N/A
1	OFF	MEMORY (Notes 2, 3)	INTERMEDIATE	Varies from INTERMEDIATE	NO
	ON	OFF	OFF	Varies from memory (Notes 2, 3,4)	YES
	ON	OFF	MIN	Varies up from MIN	N/A
2	OFF	MAX (Note 1)	MAX	Varies down from MAX	N/A
	ON	OFF	INTERMEDIATE	Varies from INTERMEDIATE	YES
	ON	OFF	OFF/MIN	Varies up from MIN	N/A
					N/A
					YES

**Note 1:** A soft turn-on is produced by slewing up the conduction angle,  $\emptyset$ , from minimum at the rate of  $1.4^\circ/4.17\text{ms}$  (60Hz). There are a total of 84 discrete values of  $\emptyset$ .

**Note 2:** A soft turn-on is produced by slewing up  $\emptyset$ , from minimum to memory. Upon power-up the memory value is defaulted to maximum conduction angle.

**Note 3:** “Memory” refers to the conduction angle,  $\emptyset$ , which existed prior to the current off-state.

**Note 4:** A soft turn-on is produced by slewing up  $\emptyset$  from minimum to memory upon which the dimming is started.

**Note 5:** **NO** = Dimming direction does not reverse from prior dimming direction. **YES** = Dimming direction does reverse from prior dimming direction. **N/A** = Does not apply.

**ABSOLUTE MAXIMUM RATINGS:**

PARAMETER	SYMBOL	VALUE	UNIT
DC supply voltage	$V_{DD} - V_{SS}$	+7	V
Any input voltage	$V_{IN}$	$V_{SS} - 0.3$ to $V_{DD} + 0.3$	V
Operating temperature	$T_A$	0 to +90	°C
Storage temperature	$T_{STG}$	-65 to +150	°C

**DC ELECTRICAL CHARACTERISTICS:**

( $T_A = +25^\circ\text{C}$ , all voltages referenced to  $V_{SS}$ .  $V_{DD} = +5\text{V}$  unless otherwise noted.)

PARAMETER	SYMBOL	MIN	TYP	MAX	UNIT	CONDITION
Supply voltage	$V_{DD}$	4.5	5.0	5.5	V	-
Supply current	$I_{DD}$	-	300	400	$\mu\text{A}$	Output unloaded $V_{DD} = 5.5\text{V}$
<b>SYNC</b> Lo	$V_{ISL}$	-	-	2.1	V	-
<b>SYNC</b> Hi	$V_{ISH}$	2.9	-	-	V	-
<b>EXT, <math>\overline{\text{SENS}}</math> Lo</b>	$V_{IEL}$	-	-	1.5	V	-
<b>EXT, <math>\overline{\text{SENS}}</math> Hi</b>	$V_{IEH}$	3.5	-	-	V	-
<b>TRIG</b> Lo	$V_{OL}$	-	0.2	-	V	-
<b>TRIG</b> Hi	$V_{OH}$	-	5.0	-	V	-
<b>TRIG</b> Sink Current	$I_{TSNK}$	35	-	-	mA	$V_{OTRIG} = 2.5\text{V}$

**TIMING CHARACTERISTICS** (See Figures 2, 3 and 4):

PARAMETER	SYMBOL	MIN	TYP	MAX	UNIT	CONDITION
<b>SYNC</b> Frequency	fs	40	-	70	Hz	-
<b>SHORT</b> Touch	Ts1	42	-	333	ms	60Hz
	Ts1	50	-	400	ms	50Hz
<b>LONG</b> Touch	Ts2	342	-	infinite	ms	60Hz
	Ts2	410	-	infinite	ms	50Hz
<b>TRIG</b> pulse width	Tw	-	130.2	-	µs	60Hz
	Tw	-	156.2	-	µs	50Hz
<b>Conduction Angle</b>	∅	41	-	158	deg	-
<b>∅ incremental steps</b>	∅	-	1.4	-	deg	-
(Note 1)						
<b>Soft-on slew rate</b>	Ss	-	1.4	-	deg/4.17ms	60Hz
	Ss	-	1.4	-	deg/5ms	50Hz
<b>A0 to A1/A2 to A0 slew rate</b>	SAA	-	1.4	-	deg/33.3ms	60Hz
(Note 2)	SAA	-	1.4	-	deg/40ms	50Hz
<b>A1 to B1/B2 to A2 slew rate</b>	SBA	-	1.4	-	deg/66.7ms	60Hz
(Note 3)	SBA	-	1.4	-	deg/80ms	50Hz
<b>B1 to B2 delay</b>	TBD	-	500	-	ms	60Hz
(Note 4)	TBD	-	600	-	ms	50Hz

**Note 1:** Total number of steps = 83.

**Note 2:** Number of steps from A0 to A1, or A2 to A0 = 68.

**Note 3:** Number of steps from A1 to B1 or B2 to A2 = 15.

**Note 4:** ∅ is at minimum between B1 and B2. TBD is applicable for LS7631 only.

For LS7632 when minimum ∅ is reached, dimming direction reverses only if the **LONG** Touch is terminated and reapplied.

**FIGURE 2. TRIG OUTPUT CONDUCTION ANGLE, ∅**

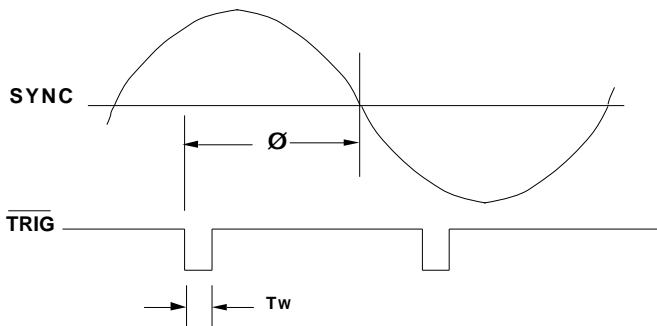

**REPLACEMENT FOR P/N SLB 0587**

LS7631 and LS7632 can be used in place of the SLB 0587 without modifying the application circuit recommended by the manufacturer of that IC.

The information included herein is believed to be accurate and reliable. However, LSI Computer Systems, Inc. assumes no responsibilities for inaccuracies, nor for any infringements of patent rights of others which may result from its use.

**FIGURE 3. LS7631 TRIG, ∅ vs TOUCH (SENS OR EXT)**

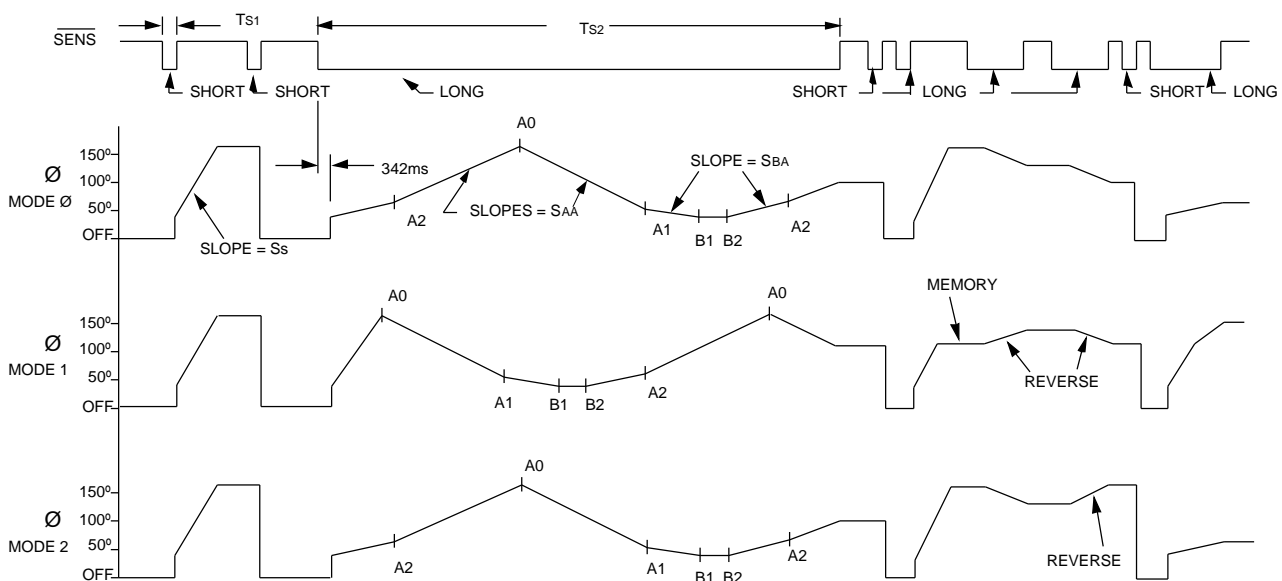

**FIGURE 4. LS7632 TRIG, Ø vs TOUCH (SENS OR EXT)**

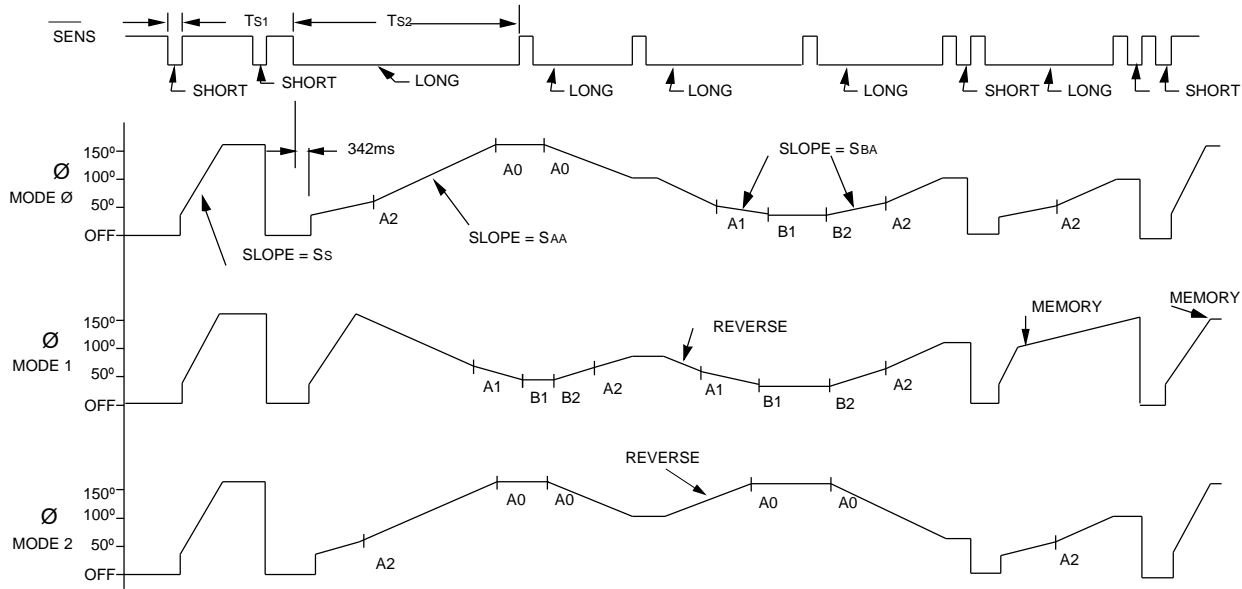

**FIGURE 6. A Typical Halogen Lamp Dimmer Wall Switch**

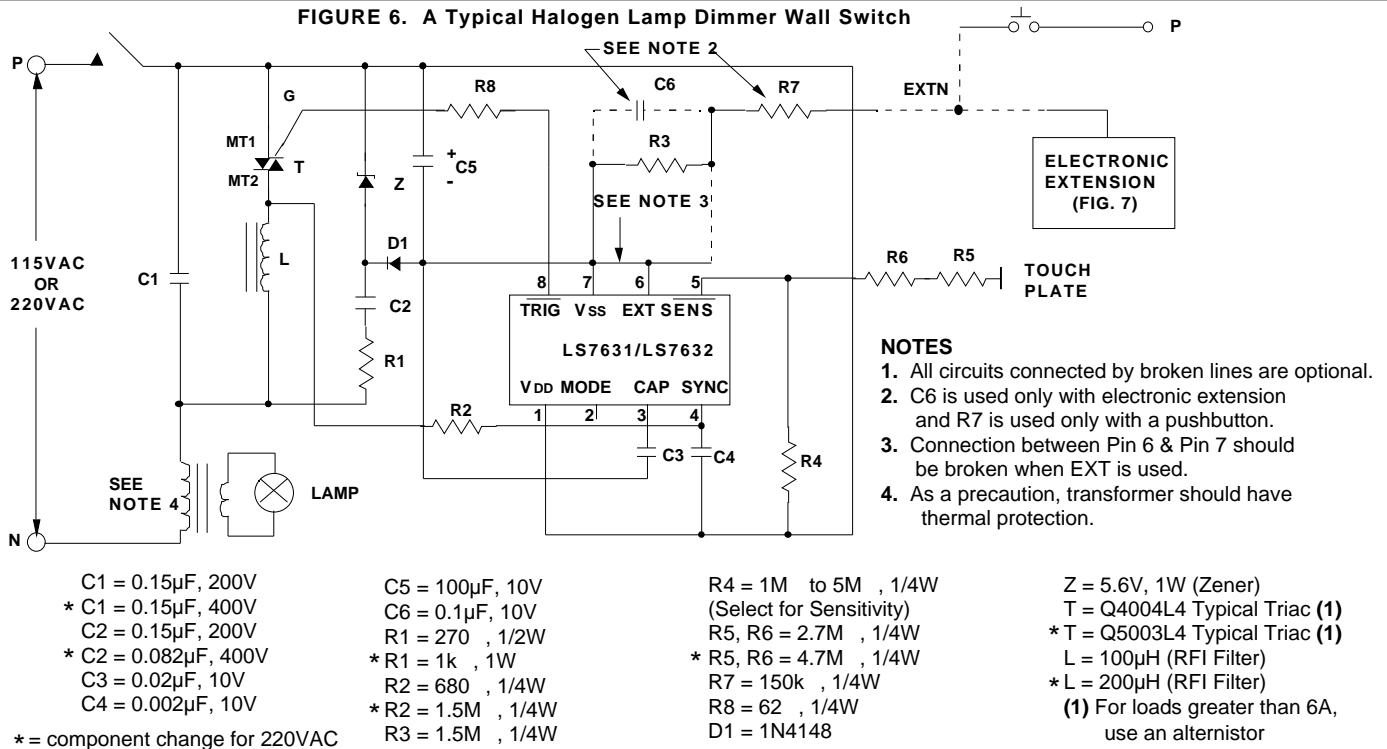

**FIGURE 7. ELECTRONIC EXTENSION**

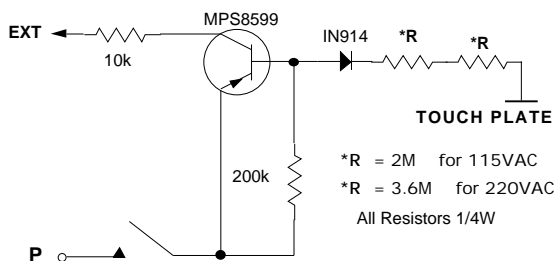

**EXTENSIONS:** All switching and dimming functions can be implemented by utilizing the EXT input. Use a pushbutton or the electronic switch in conjunction with a Touch Plate as shown in Figure 7. When the plate is touched, a logic high level is generated at the EXT input of the IC for both half-cycles of the line frequency. (See Figure 6)

**APPLICATION EXAMPLE:**

A typical implementation of the light dimmer circuit is shown in Fig. 6. Here the brightness of the lamp is set by touching the touch plate. The function of different components are as follows:

- The 5V DC supply for the chip is provided by Z, D1, R1, C2 and C5.
- R2 and C4 generate the filtered signal for the SYNC input for synchronizing the internal PLL with the line frequency.
- R3 and C6 act as a filter circuit for the electronic extension. If extensions are not used, the EXT input (Pin 6) should be tied to Vss (Pin 7).
- R4, R5 and R6 set up the sensitivity of the SENS input.
- C3 is the filter capacitor for the internal PLL.
- R8 provides current limiting and isolation between the chip output and the triac gate.
- C1 and L are RFI filter circuits.

This datasheet has been download from:

[www.datasheetcatalog.com](http://www.datasheetcatalog.com)

Datasheets for electronics components.