

Total solder points: 271

Difficulty level: *beginner* 1  2  3  4  5  *advanced*

## 2 x 15 LED STEREO VU METER

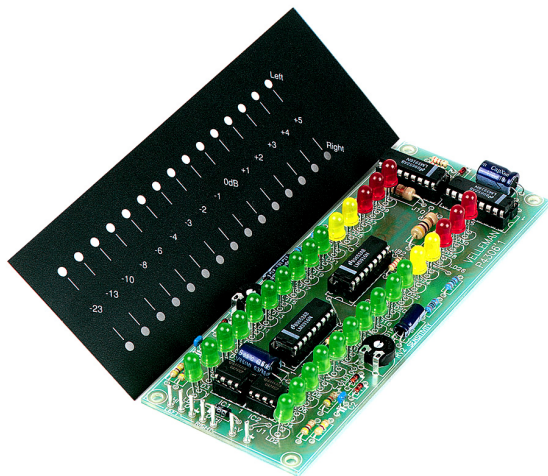

# K4306

For high precision audio level  
indication

**Features:**

- ☑ For visualization of audio signals.
- ☑ Use with mixing panels, amplifiers, car audio systems...
- ☑ Easily connects to the line-level output (LOW INPUT) from any tape deck, stereo system, or CD player.
- ☑ A special input (HIGH INPUT) is provided, so that the unit can directly be connected to the speaker output of most systems\*.
- ☑ To make it universal, the readout can be set as DOT or BAR indication.
- ☑ The supplied display window for vertical or horizontal mounting, makes the unit very attractive.

**Specifications:**

- Bar or dot readout.
- Scale: -23dB to +5dB, 15 LED's per channel.
- dB-linear division from -4 to +5dB (1dB per led).
- Systematically growing steps below -4dB.
- Accuracy:  $\pm 0.5$ dB (1KHz).
- Frequency range: 20Hz to 30KHz (-3dB).
- Three different LED colors: green, orange and red.
- Adjustable input sensitivity: 150mV to 5Vrms Low input  
1.5V to 50Vrms High input
- Input impedance: 47K Low input / 470K High input
- Power supply: 12 to 15VDC / 300mA
- Dimensions: 150 x 57mm

 **NOT SUITED FOR CONNECTION TO HIGH POWER CAR STEREO SYSTEM**

### 1. Assembly (Skipping this can lead to troubles !)

Ok, so we have your attention. These hints will help you to make this project successful. Read them carefully.

#### 1.1 Make sure you have the right tools:

- A good quality soldering iron (25-40W) with a small tip.
- Wipe it often on a wet sponge or cloth, to keep it clean; then apply solder to the tip, to give it a wet look. This is called 'thinning' and will protect the tip, and enables you to make good connections. When solder rolls off the tip, it needs cleaning.
- Thin raisin-core solder. Do not use any flux or grease.
- A diagonal cutter to trim excess wires. To avoid injury when cutting excess leads, hold the lead so they cannot fly towards the eyes.
- Needle nose pliers, for bending leads, or to hold components in place.
- Small blade and Phillips screwdrivers. A basic range is fine.

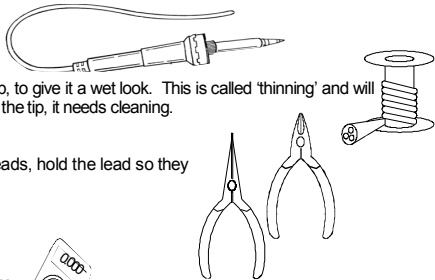

**For some projects, a basic multi-meter is required, or might be handy**

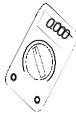

#### 1.2 Assembly Hints :

- ⇒ Make sure the skill level matches your experience, to avoid disappointments.
  - ⇒ Follow the instructions carefully. Read and understand the entire step before you perform each operation.
  - ⇒ Perform the assembly in the correct order as stated in this manual
  - ⇒ Position all parts on the PCB (Printed Circuit Board) as shown on the drawings.
  - ⇒ Values on the circuit diagram are subject to changes.
  - ⇒ Values in this assembly guide are correct\*
  - ⇒ Use the check-boxes to mark your progress.
  - ⇒ Please read the included information on safety and customer service
- \* Typographical inaccuracies excluded. Always look for possible last minute manual updates, indicated as 'NOTE' on a separate leaflet.

### 1.3 Soldering Hints :

1- Mount the component against the PCB surface and carefully solder the leads

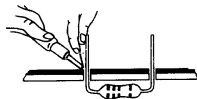

2- Make sure the solder joints are cone-shaped and shiny

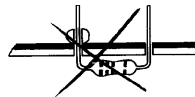
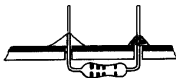

3- Trim excess leads as close as possible to the solder joint

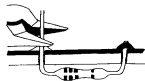

REMOVE THEM FROM THE TAPE ONE AT A TIME !

**DO NOT BLINDLY FOLLOW THE ORDER OF THE COMPONENTS ONTO THE TAPE. ALWAYS CHECK THEIR VALUE ON THE PARTS LIST!**

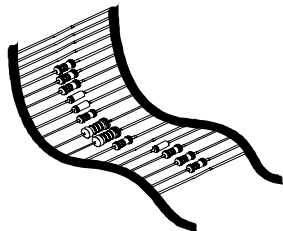

# 1. Jumper wires

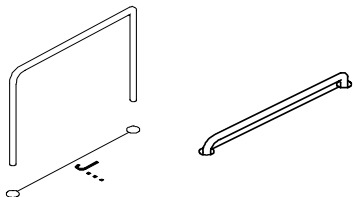

- |                             |                              |
|-----------------------------|------------------------------|
| <input type="checkbox"/> J1 | <input type="checkbox"/> J7  |
| <input type="checkbox"/> J2 | <input type="checkbox"/> J8  |
| <input type="checkbox"/> J3 | <input type="checkbox"/> J9  |
| <input type="checkbox"/> J4 | <input type="checkbox"/> J10 |
| <input type="checkbox"/> J5 | <input type="checkbox"/> J11 |
| <input type="checkbox"/> J6 |                              |

## BAR readout :

- JB1
- JB2
- JB3
- JB4

## DOT readout :

- JD1
- JD2

BAR

DOT

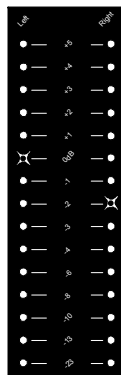
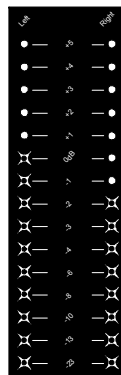

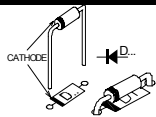
**2. Diodes. Watch the polarity !**

- D1 : 1N4148
- D2 : 1N4148
- D3 : 1N4148
- D4 : 1N4148
- D5 : 1N4148
- D6 : 1N4148
- D7 : 1N4148
- D8 : 1N4148
- D9 : 1N4007

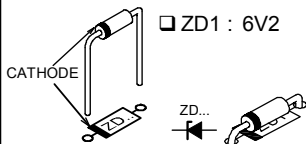
**3. Zenerdiode. Watch the polarity !**

ZD1 : 6V2

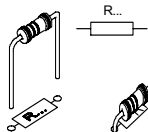
**4. Metal film resistors**

- R1 : 3K (3-0-0-1-1)
- R2 : 3K9 (3-9-0-1-1)
- R3 : 3K (3-0-0-1-1)
- R4 : 3K9 (3-9-0-1-1)

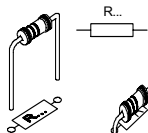
**5. Resistors**

- R5 : 470K (4-7-4-B)
- R6 : 47K (4-7-3-B)
- R7 : 47K (4-7-3-B)
- R8 : 470K (4-7-4-B)
- R9 : 47K (4-7-3-B)

- R10 : 47K (4-7-3-B)
- R11 : 2K2 (2-2-2-B)
- R12 : 18K (1-8-3-B)
- R13 : 18K (1-8-3-B)
- R14 : 2K2 (2-2-2-B)
- R15 : 1K (1-0-2-B)
- R16 : 1K (1-0-2-B)
- R17 : 2K2 (2-2-2-B)
- R18 : 2K2 (2-2-2-B)
- R19 : 2K2 (2-2-2-B)
- R20 : 330 (3-3-1-B)

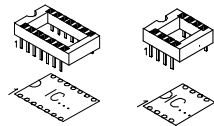
**6. IC sockets. Watch the position of the notch!**

- IC1 : 8p
- IC2 : 8p
- IC3 : 18p
- IC4 : 18p
- IC5 : 18p
- IC6 : 18p

### 7. Capacitors.

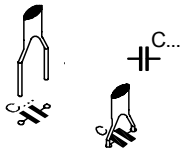

- C1 : 220nF (224)
- C2 : 220nF (224)
- C3 : 220nF (224)

### 8. Trim potentiometers

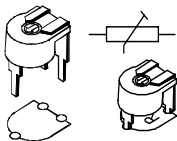

- RV1 : 220K
- RV2 : 220K

### 9. Electrolytic Capacitors. Watch the polarity !

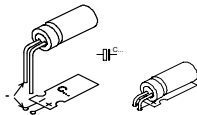

- C4 : 470 $\mu$ F
- C5 : 47 $\mu$ F
- C6 : 47 $\mu$ F
- C7 : 470 $\mu$ F

### 10. 1W resistors

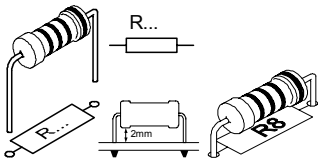

- R21 : 47 (4 - 7 - 0 - B)
- R22 : 47 (4 - 7 - 0 - B)

### 11. LEDs. Watch the polarity!

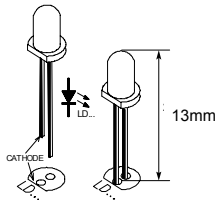

- LD1 : green
- LD2 : green
- LD3 : green
- LD4 : green
- LD5 : green
- LD6 : green
- LD7 : green
- LD8 : green
- LD9 : green
- LD10 : green
- LD11 : green
- LD12 : green

- LD13 : green
- LD14 : green
- LD15 : green
- LD16 : green
- LD17 : green
- LD18 : green
- LD19 : green
- LD20 : green
- LD21 : yellow
- LD22 : yellow
- LD23 : yellow
- LD24 : yellow
- LD25 : red
- LD26 : red
- LD27 : red
- LD28 : red
- LD29 : red
- LD30 : red

## 12. IC's. Watch the polarity !

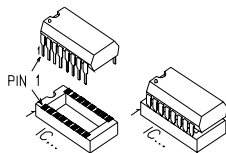

- IC1 : 741
- IC2 : 741
- IC3 : LM3916
- IC4 : LM3916
- IC5 : LM3916
- IC6 : LM3916



### 13. Assembly

(A) Make the holes in the housing or panel (fig.1.0) :

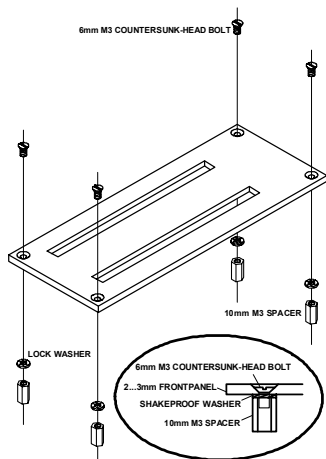

(B) Mount the suitable spacers (fig. 2.0) :

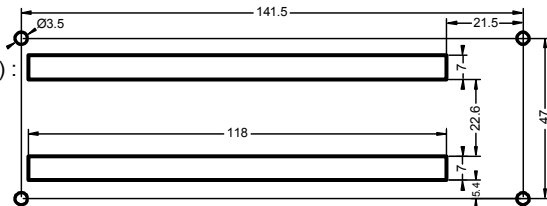

Fig. 1.0

Fig. 2.0

(C) Mount the PCB onto the spacers (fig 3.0) :

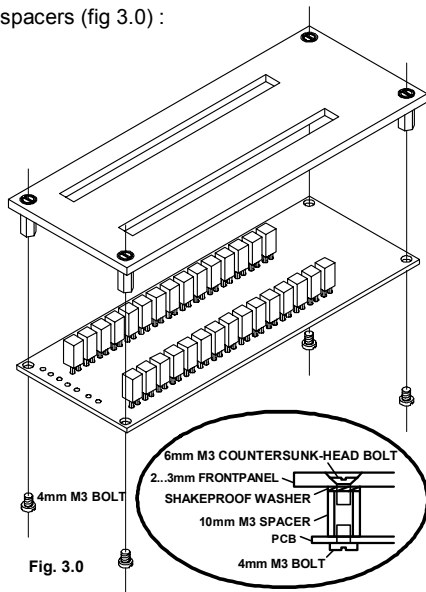

Fig. 3.0

## 14. Connection to a suitable signal

Connecting to a line level output (tuner, preamplifier, cd player... ) and connecting a power supply from 12 to 15VDC / 300mA max..

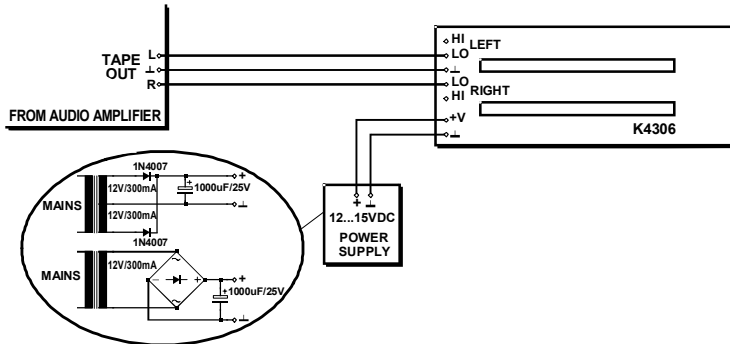

Fig. 4.0

Connect the unit to a suitable supply voltage between 12VDC and 15VDC, this can also be a standard DC adapter. You can also build your own power supply, see diagram. Use a 2x12V transformer, two rectifier diodes and a electrolytic capacitor or use a single 12V transformer with a bridge rectifier and a electrolytic capacitor.

## 15. Connection to a speaker output

Connecting to a speaker level output and connecting a power supply from 12 to 15VDC / 300mA max.

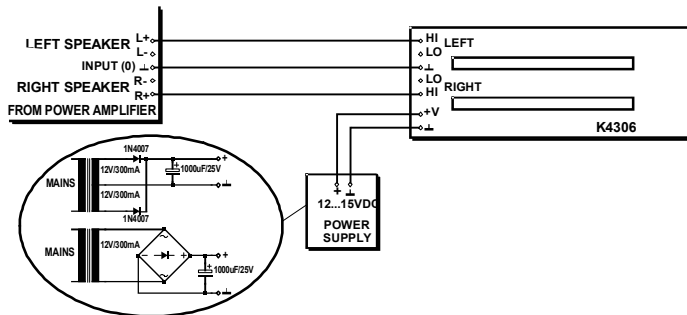

Fig. 5.0

Connect the unit to a suitable supply voltage between 12VDC and 15VDC, this can also be a standard DC adapter. You can also build your own power supply, see diagram. Use a 2x12V transformer, two rectifier diodes and a electrolytic capacitor or use a single 12V transformer with a bridge rectifier and a electrolytic capacitor.

## 16. Connection to a car radio

Connecting to a speaker output from a regular car radio.

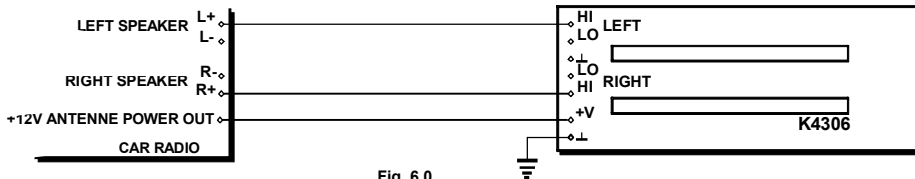
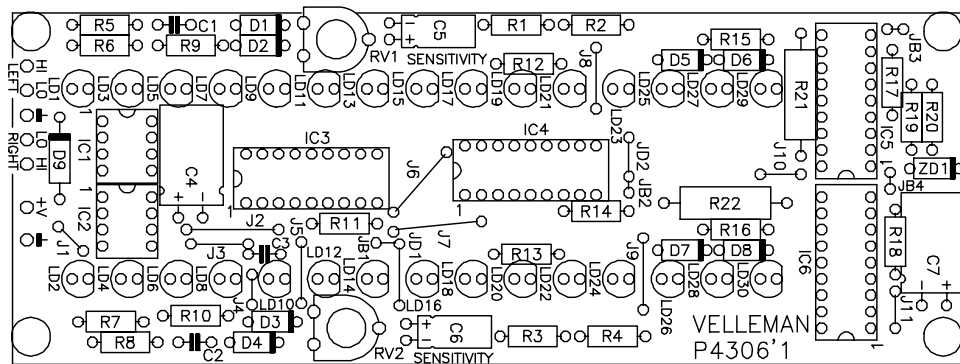

Fig. 6.0

**REMARK:** Do not connect the unit to a high power car booster or car stereo, this equipment uses isolated ground connection. The connection to this kind of amplifier can cause permanent damage to the amplifier or car radio!

Adjust the units sensitivity according to your preference by means of the trim potentiometer RV1

## 17. PCB LAYOUT



# 18. DIAGRAM

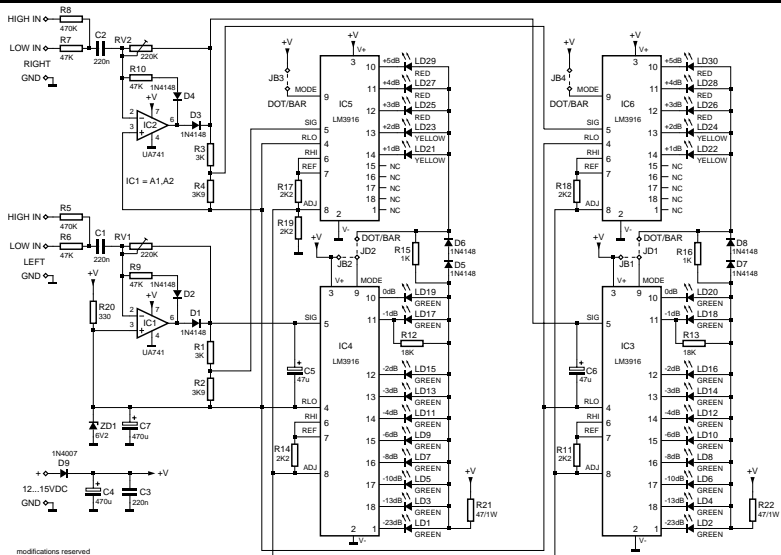

**VELBUS**  
Velleman Home Automation System

**VELBUS**  
Velleman Home Automation System

**All appliances get intelligent, how about your home?  
see our website : [www.velbus.be](http://www.velbus.be)**

Modifications and typographical errors reserved  
 © Velleman nv.  
 H4306IP - 2004 - ED1

**VELLEMAN NV**  
**Legen Heirweg 33, 9890 Gavere**  
**Belgium - Europe**

