

**SANYO****LC7267****Digital Display of Clock/Receiving Frequency  
for Radio Set Applications****Functions**

- Capable of selecting receiving frequency display/time display.
- Display of receiving frequency at each band of FM/MW/LW
 

Display element:	LED
Static/dynamic:	Static
Withstand voltage at output pin:	15 V
Maximum current:	18 mA
	( $V_{DD} = 6.0$ to $10.0$ V)
- Number of display digits:
 

FM:	5 digits, MW, LW: 4 digits
-----	----------------------------
- Covers intermediate frequencies shown below.
 

FM:	+10.700, +10.725, +10.750, +10.675 MHz
	-10.700, -10.725, -10.675, -10.650 MHz
MW, LW:	+450 kHz (1) : 10 kHz-step display
	+450 kHz (2) : 1 kHz-step display
	+455 kHz : 1 kHz-step display
	+469 kHz : 1 kHz-step display
- In FM reception applications, the LB3500 ( $\pm 8$  prescaler) is used jointly.
- Two selections of display system (12-hour system with PM sign, 24-hour system).
- Easy to set time by the time signal.
- Inhibit pin for inhibiting time setting with display unlighted.
- 7.2 MHz crystal oscillator for reference frequency.
- Supply voltage  $V_{DD}$ : 4.5 to 10.0 V.

**Package Dimensions**

unit : mm

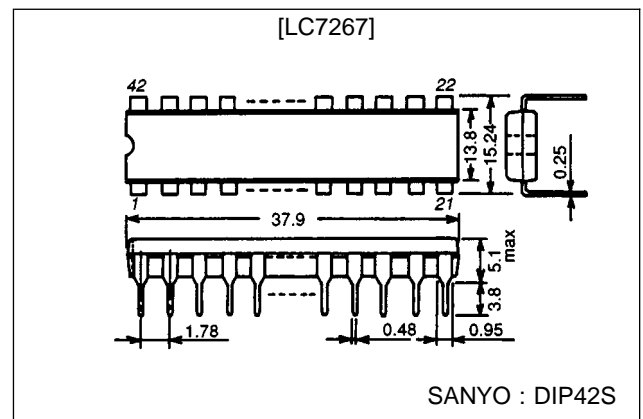
**3025B-DIP42S**

## Specifications

### Absolute Maximum Ratings at $V_{SS} = 0\text{ V}$

Parameter	Symbol	Conditions	Ratings	Unit
Maximum supply voltage	$V_{DD\text{ max}}$		-0.3 to +11	V
Input voltage	$V_{IN}$		-0.3 to $V_{DD}+0.3$	V
Output voltage	$V_{O1}$	$X_{OUT}$	-0.3 to $V_{DD}+0.3$	V
	$V_{O2}$	Output pins other than $X_{OUT}$ , output : off	0 to 15	V
Allowable power dissipation	$P_d\text{ max}$	$T_a \leq 65^\circ\text{C}$	550	mW
Allowable power dissipation of segment outputs	Pd seg 1	$\overline{PM}$ $V_{DD} = 4.5$ to $6\text{ V}$ , $I_{OL} = 50\text{ mA}$	35	mW
	Pd seg 2	$\overline{b\&e}$ $V_{DD} = 4.5$ to $6\text{ V}$ , $I_{OL} = 33\text{ mA}$	30	mW
	Pd seg 3	Other outputs $V_{DD} = 4.5$ to $6.5\text{ V}$ , $I_{OL} = 16.5\text{ mA}$	15	mW
	Pd seg 4	$\overline{PM}$ $V_{DD} = 6.0$ to $10\text{ V}$ , $I_{OL} = 54\text{ mA}$	38	mW
	Pd seg 5	$\overline{b\&e}$ $V_{DD} = 6.0$ to $10\text{ V}$ , $I_{OL} = 36\text{ mA}$	25	mW
	Pd seg 6	Other outputs $V_{DD} = 6.0$ to $10\text{ V}$ , $I_{OL} = 18\text{ mA}$	13	mW
Operating temperature	$T_{opr}$		-30 to +65	$^\circ\text{C}$
Storage temperature	$T_{stg}$		-40 to +125	$^\circ\text{C}$

### Allowable Operating Conditions at $T_a = 25^\circ\text{C}$ , $V_{SS} = 0\text{ V}$ , $V_{DD} = 4.5$ to $10\text{ V}$

Parameter	Symbol	Conditions	min	typ	max	Unit
Supply voltage	$V_{DD}$		4.5		10	V
Input high-level voltage	$V_{IH1}$	$\overline{INH\bar{I}}$ , CTR/CLK, DEMAND	$0.8V_{DD}$		$V_{DD}$	V
	$V_{IH2}$	SET, FM/AM	$0.85V_{DD}$		$V_{DD}$	V
	$V_{IH3}$	FIF1, FIF2, FIF3 AIF1, AIF2, 12H/24H	$0.9V_{DD}$		$V_{DD}$	V
Input low-level voltage	$V_{IL1}$	$\overline{INH\bar{I}}$ , CTR/CLK, DEMAND	0		$0.2V_{DD}$	V
	$V_{IL2}$	SET, FM/AM	0		$0.15V_{DD}$	V
	$V_{IL3}$	FIF1, FIF2, FIF3 AIF1, AIF2, 12H/24H	0		$0.1V_{DD}$	V
Input medium-level voltage	$V_{IM}$	SET	$0.45V_{DD}$		$0.55V_{DD}$	V
Input frequency	$f_{IN1}$	FMI, sine wave, capacitive coupling, $V_{IN1} = 0.7V_{p-p}$	1		18	MHz
	$f_{IN2}$	AMI, sine wave, capacitive coupling, $V_{IN2} = 0.5V_{p-p}$	0.5		3	MHz
	$f_{IN3}$	XIN, sine wave, capacitive coupling, $V_{IN3} = 1V_{p-p}$	0.2		7.5	MHz
Input amplitude	$V_{IN1}$	FMI, sine wave, capacitive coupling, $f_{IN1} = 1$ to $18\text{ MHz}$	0.7		$0.9V_{DD}$	Vp-p
	$V_{IN2}$	AMI, sine wave, capacitive coupling, $f_{IN2} = 0.5$ to $3\text{ MHz}$	0.5		$0.9V_{DD}$	Vp-p
	$V_{IN3}$	XIN, sine wave, capacitive coupling, $f_{IN3} = 0.2$ to $7.5\text{ MHz}$	1.0		$0.9V_{DD}$	Vp-p
Segment current	Iseg 1	$\overline{PM}$			45	mA
	Iseg 2	$\overline{b\&e}$			30	mA
	Iseg 3	Other outputs seg			15	mA

### Electrical Characteristics at $V_{DD} = 4.5$ to $10\text{ V}$ , $V_{SS} = 0\text{ V}$

Parameter	Symbol	Conditions	min	typ	max	Unit
Input high-level current	$I_{IH1}$	FIF1 to FIF3, AIF1 to AIF2, SET, FM/AM, 12H/24H CTR/CLK, $V_I = V_{DD}$	0		10	$\mu\text{A}$
	$I_{IH2}$	$\overline{INH\bar{I}}$ , $V_I = V_{SS}$	40		1000	$\mu\text{A}$
	$I_{IH3}$	DEMAND, $V_I = V_{DD}$	40		1000	$\mu\text{A}$
Input low-level current	$I_{IL}$	FIF1 to FIF3, AIF1 to AIF2, SET, FM/AM, 12H/24H, CTR/CLK, $V_I = V_{SS}$	-10		0	$\mu\text{A}$
Input floating voltage	$V_{IF1}$	$\overline{INH\bar{I}}$ , $V_I = \text{open}$	0		0.2	V
	$V_{IF2}$	DEMAND, $V_I = \text{open}$	0		$0.1V_{DD}$	V

Continued next page.

# LC7267

Continued from preceding page.

Parameter	Symbol	Conditions	min	typ	max	Unit
Output low-level voltage	$V_{OL1}$	PM $V_{DD} = 4.5$ to $10$ V, $I_{OL} = 45$ mA	0		1.0	V
	$V_{OL2}$	b&e $V_{DD} = 4.5$ to $10$ V, $I_{OL} = 30$ mA	0		1.0	V
	$V_{OL3}$	Other outputs seg, $V_{DD} = 4.5$ to $10$ V, $I_{OL} = 15$ mA	0		1.0	V
Output off leakage current	$I_{OFF}$	All segments output pins, $V_{OUT} = 13$ V	0		10	$\mu$ A
Current drain	$I_{DD}$	FM mode, FM/AM = $V_{DD}$ , $f_{IN1} = 18$ MHz, $0.7V_{p-p}$ (or AM mode, FM/AM = $V_{SS}$ , $f_{IN2} = 3$ MHz, $0.5V_{p-p}$ ) $f_{IN3} = 7.2$ MHz, $1V_{p-p}$ , FIF1, FIF2, FIF3 = $V_{DD}$ AIF1, AIF2 = $V_{DD}$ 12H/24H, CTR/CLK, INHI, DEMAND = $V_{DD}$			18	mA

## Pin Assignment

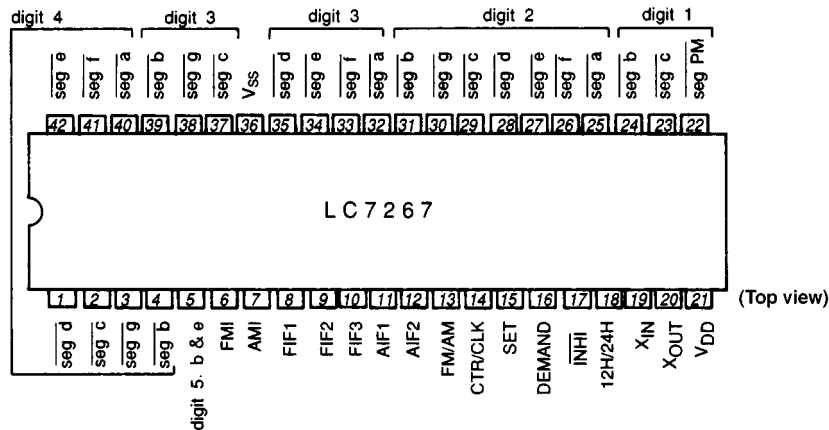

## Configuration and Display Font

4 or 4-1/2-digit segment LED's are used to display time and frequency in the display font shown below.

Font 1234567890

## Lighting System

Static lighting

### Display Range

- Frequency (MW, LW) 000 kHz to 1999 kHz (The highest-order digit "0" is blanked out.)
- Frequency (FM) 00.00 MHz to 199.95 MHz (The highest-order digit "0" is blanked out.)
- Clock (12-hour) PM 12:00 to PM 11:59 → 12:00 to 11:59  
↑
- Clock (24-hour) 0:00 to 23:59 (The highest-order digit "0" is blanked out.)

## Pin Description

- $\bar{a}$  to  $\bar{g}$ ,  $\overline{PM}$ ,  $\bar{b\&e}$ : LED driver pin

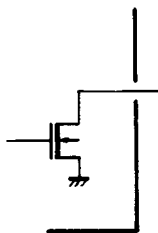

## LC7267

- $V_{DD}$ ,  $V_{SS}$ : Power supply pin
- $X_{IN}$ ,  $X_{OUT}$ : Crystal oscillator, input amplifier pin

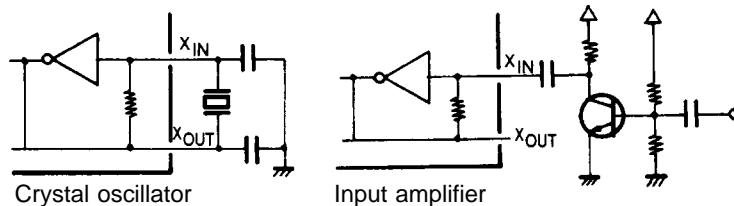

- FIF1, FIF2, FIF3: FM IF offset value select pin

FIF1	0	0	0	0	1	1	1	1
FIF2	0	0	1	1	0	0	1	1
FIF3	0	1	0	1	0	1	0	1
IF (MHz)	+10.700	+10.725	+10.675	+10.750	-10.700	-10.725	-10.675	-10.650

- AIF1, AIF2: AM IF offset value select pin

AIF1	0	0	1	1
AIF2	1	0	0	1
IF (kHz)	+450 (1)	+450 (2)	+455	+469
Display step	10 kHz	1 kHz step		

1: High level  
0: Low level

(Note) 450 kHz (1): 10 kHz-step display, others: 1 kHz-step display

- FMI, AMI: Local OSC signal input pin  
FMI: For FM  
AMI: For MW, LW
- FM/AM: FM/MW, LW select pin  
FM: High level  
MW, LW: Low level
- CTR/CLK: Frequency display/time display select pin  
CTR (Counter): High level  
CLK (Clock): Low level
- DEMAND: Input pin for instructing execution of setting

CTR/CLK	DEMAND	MODE
0	1	Mode of setting by the time signal and hours-minutes setting mode
0	0	Time display mode

- SET: Input pin for setting hours-minutes

This pin is set at "M" level normally. The input signal of "H"/"L" level acts as follows:

When in the mode of setting by the time signal and hours-minutes setting mode (CTR/CLK = "L", DEMAND = "H")

High level: Execution of hours setting

Advance at a 2 Hz rate 1.2 seconds after the pin is set to "H" level.

Low level: Execution of setting by the time signal and minutes setting

Advance at a 2 Hz rate 1.2 seconds after the pin is set to "L" level.

Setting by the time signal is executed when the pin is set off within 1.0 second after set to "L" level.

No carry to high-order digit occurs.

- $\overline{\text{INH}}$ : Input pin for turning OFF the segment pins, inhibiting the SET/DEMAND pin from functioning, and preventing the AMI amp from operating  
High level: Normal operation  
Low level: Segment pin OFF, SET/DEMAND pin function inhibit
- 12H/24H: Input pin for selecting 12-hour system with PM sign/24-hour system  
High level: 12-hour system with PM sign  
Low level: 24-hour system

Make connection of the highest-order digit as shown below.

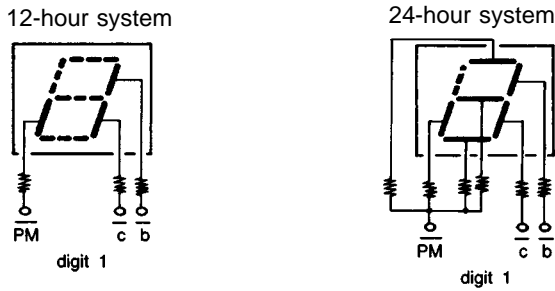

**Timing Chart**

Time setting (CTR/CLK = "L")

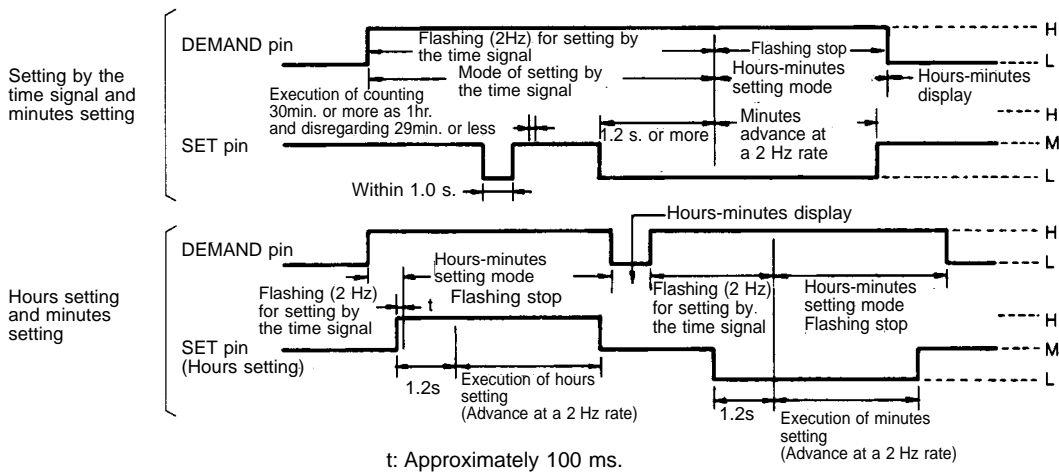

**Sample Display at Each Display**

(Setting by the time signal, hours-minutes display, hours-minutes setting)

**Setting by the time signal: Setting to PM 12:00**

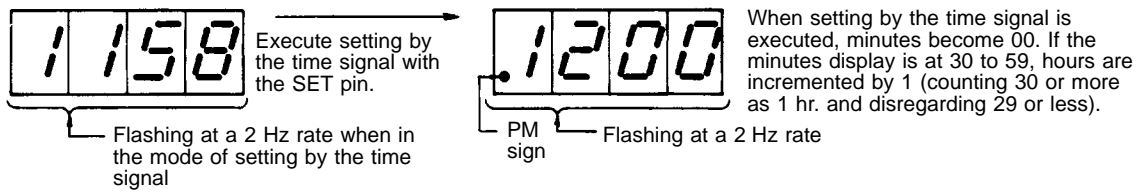

**Hours-minutes display: Display of PM 12:34**

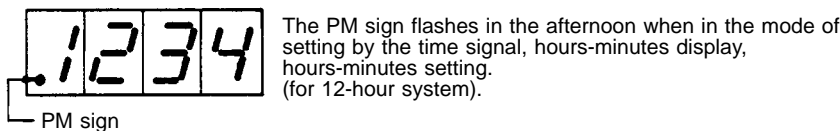

**Hours-minutes setting: Setting to PM 11:45 from PM 11:23**

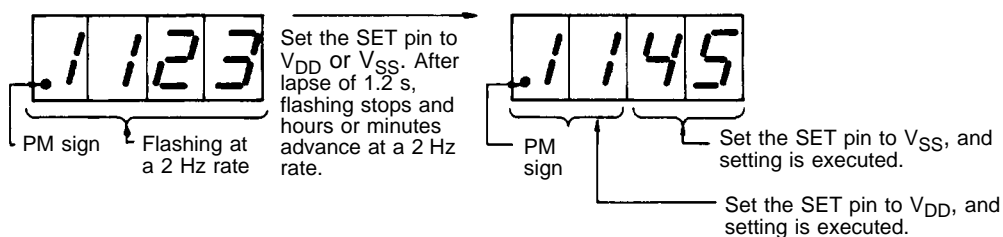

Equivalent Circuit Block Diagram

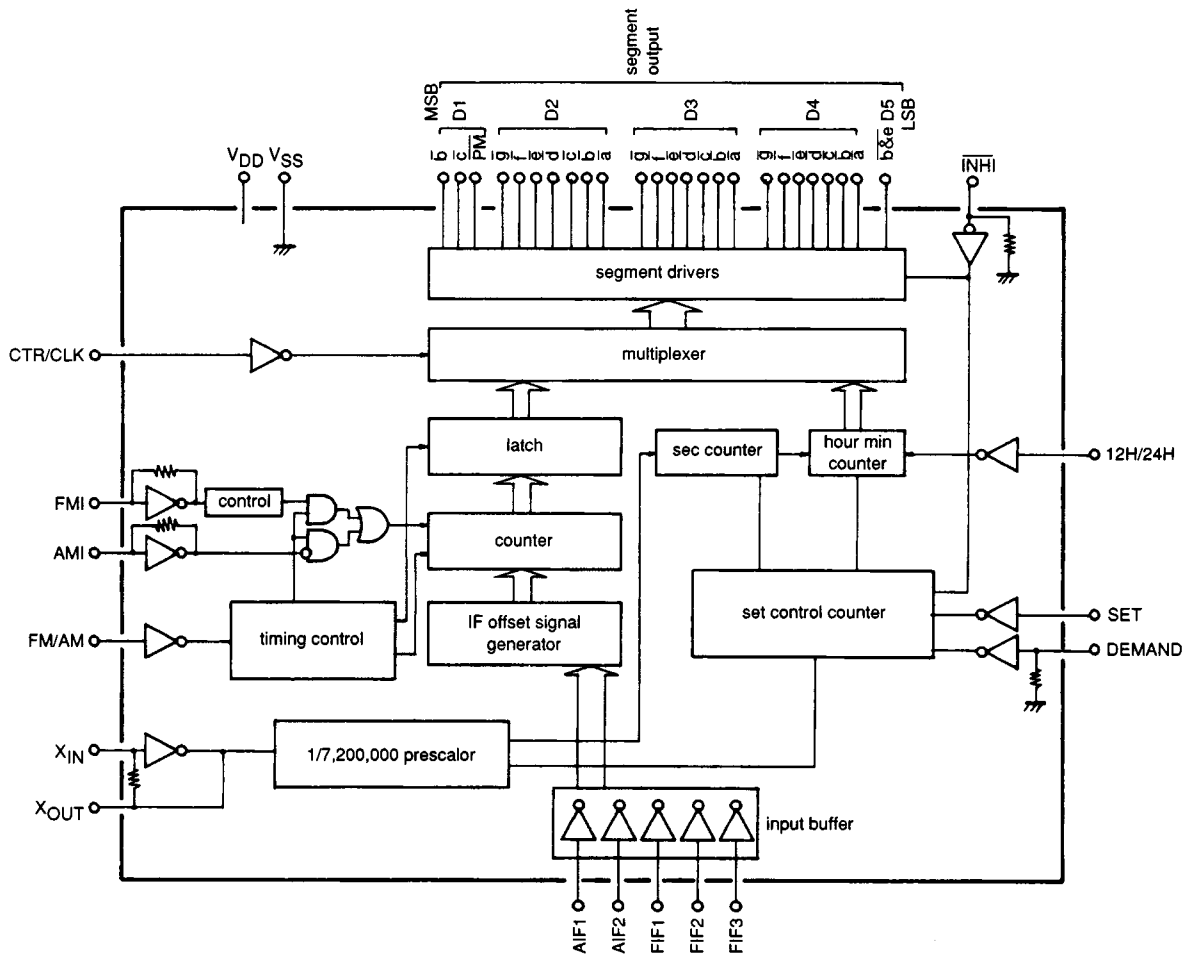

Sample Application Circuit 1

5-digit display in FM use

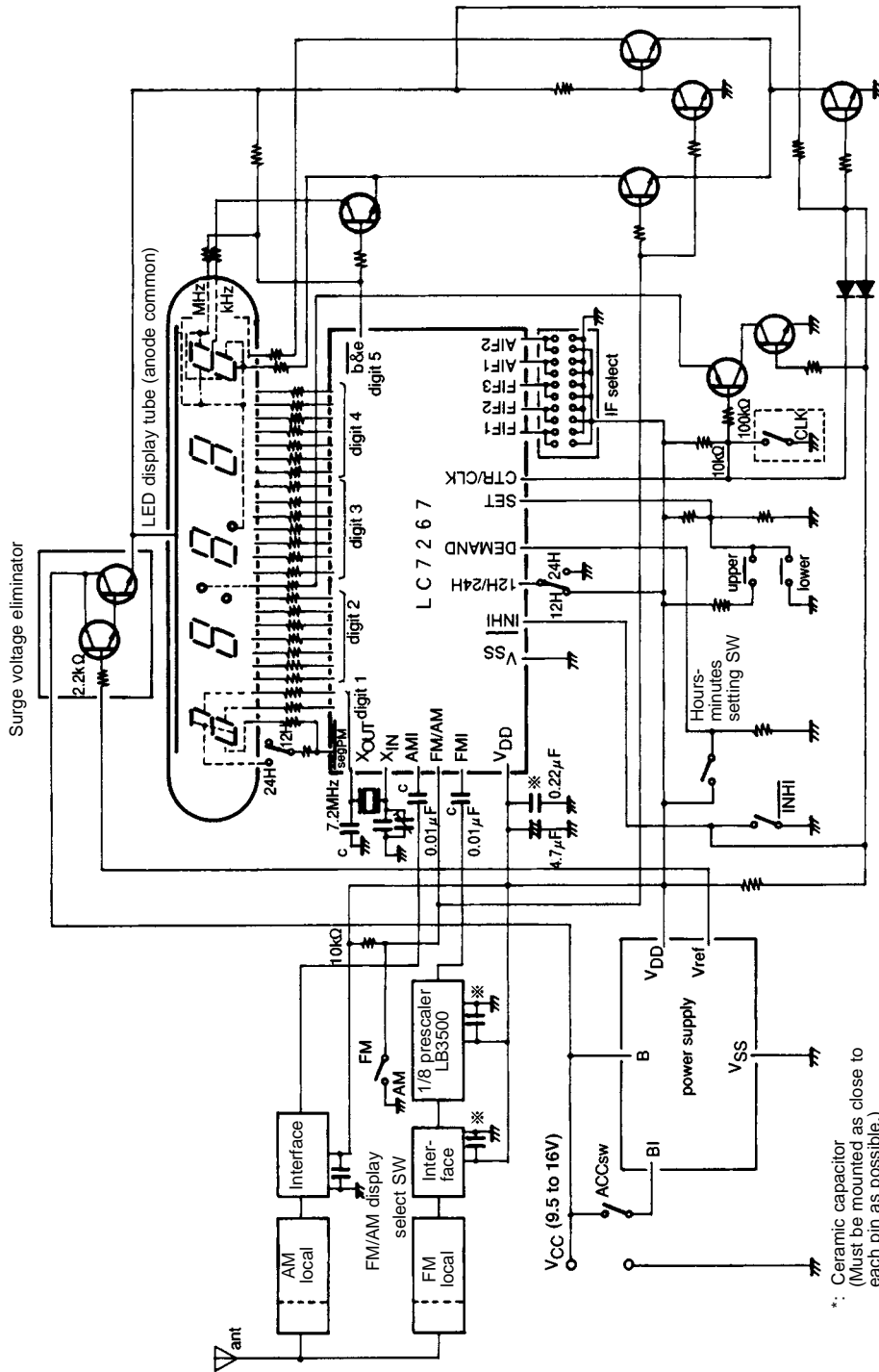

\*: Ceramic capacitor (Must be mounted as close to each pin as possible.)

Sample Application Circuit 2

4-digit display in FM use

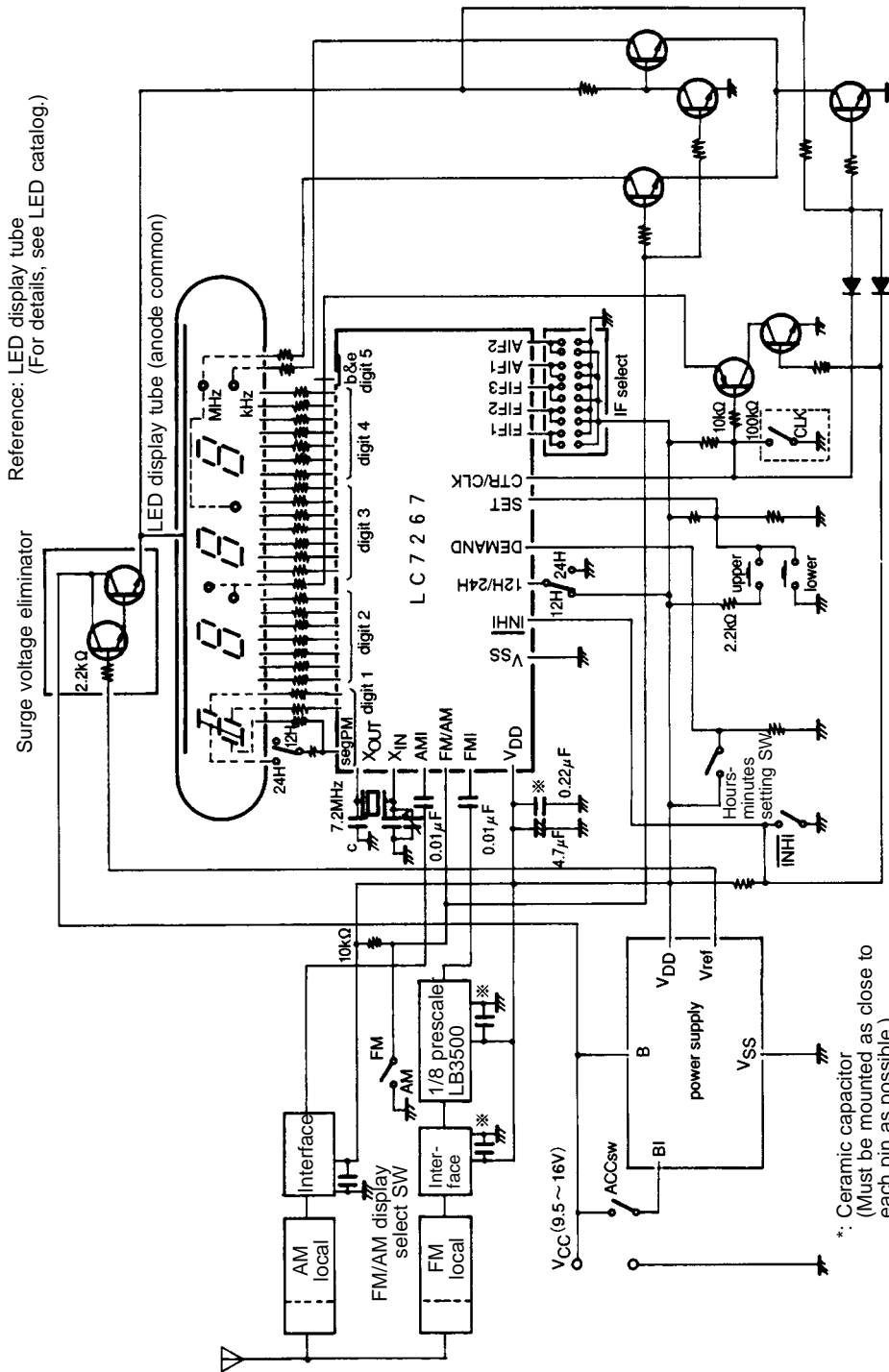

(Note) How to reduce current dissipation when display is turned off

To reduce current dissipation when display is turned off (INHI: "L"), the circuit shown below must be connected to the FMI pin.

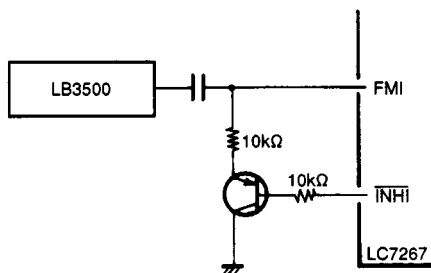



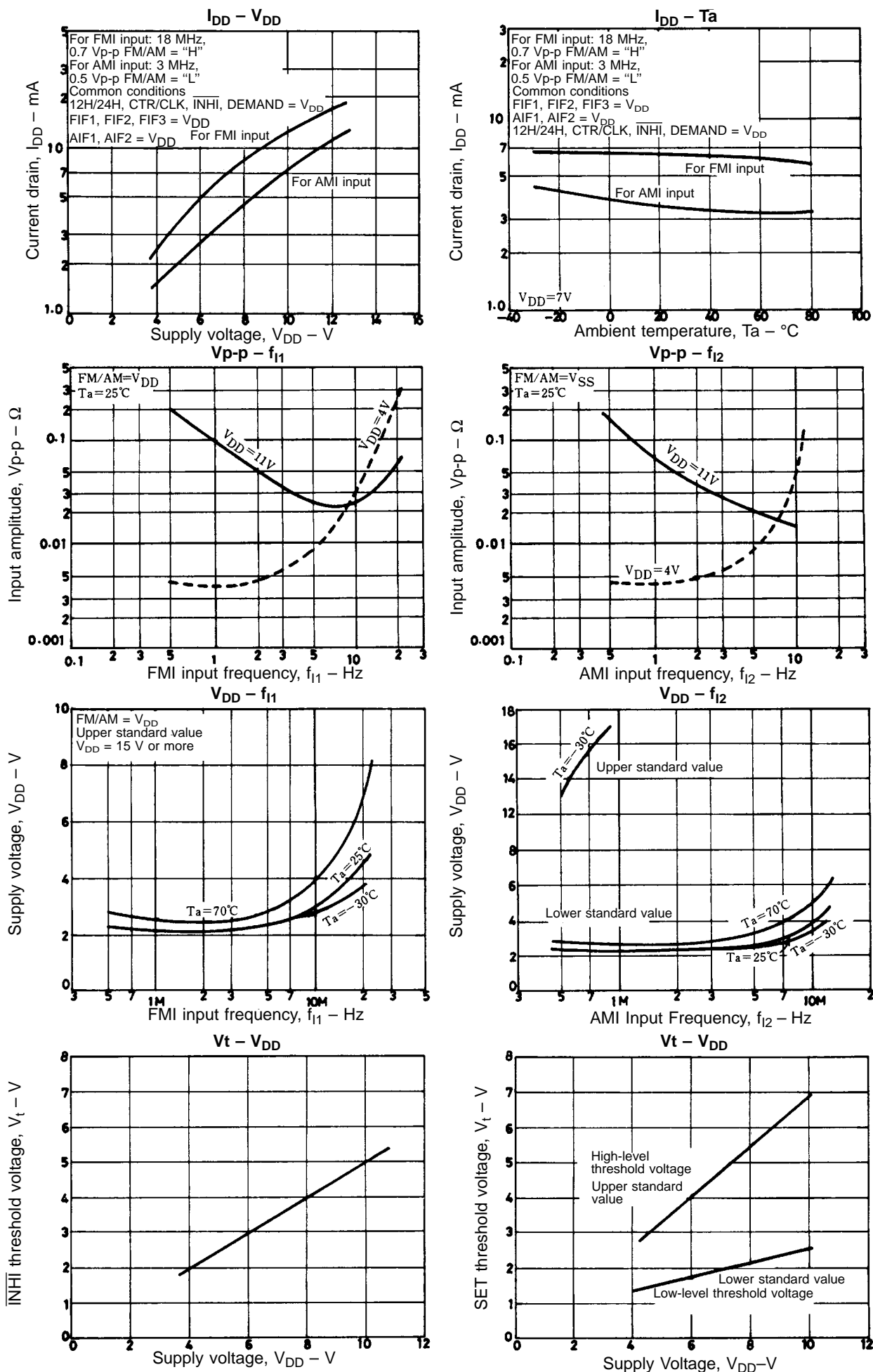

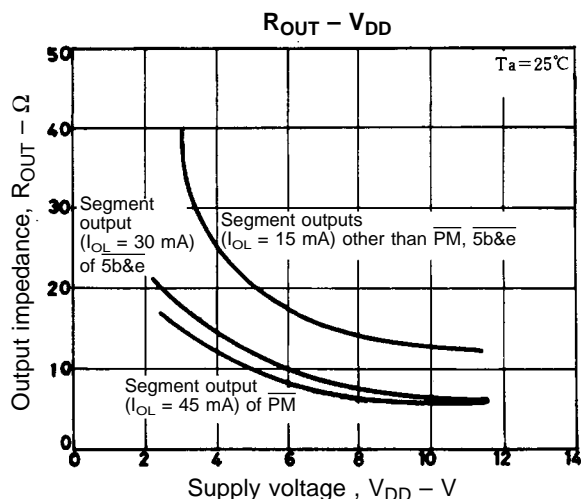
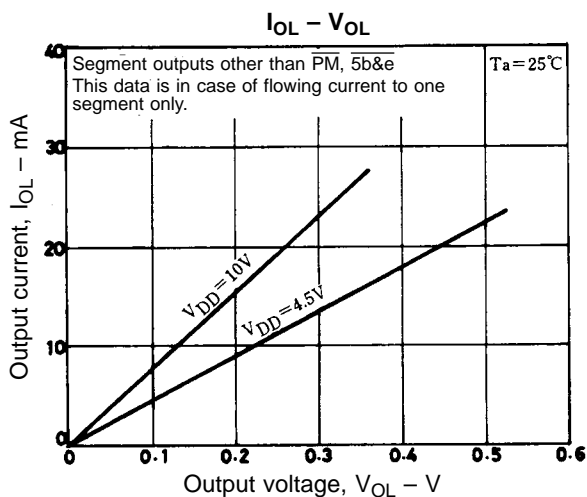

- No products described or contained herein are intended for use in surgical implants, life-support systems, aerospace equipment, nuclear power control systems, vehicles, disaster/crime-prevention equipment and the like, the failure of which may directly or indirectly cause injury, death or property loss.
- Anyone purchasing any products described or contained herein for an above-mentioned use shall:
  - ① Accept full responsibility and indemnify and defend SANYO ELECTRIC CO., LTD., its affiliates, subsidiaries and distributors and all their officers and employees, jointly and severally, against any and all claims and litigation and all damages, cost and expenses associated with such use:
  - ② Not impose any responsibility for any fault or negligence which may be cited in any such claim or litigation on SANYO ELECTRIC CO., LTD., its affiliates, subsidiaries and distributors or any of their officers and employees jointly or severally.
- Information (including circuit diagrams and circuit parameters) herein is for example only; it is not guaranteed for volume production. SANYO believes information herein is accurate and reliable, but no guarantees are made or implied regarding its use or any infringements of intellectual property rights or other rights of third parties.

This catalog provides information as of June, 1998. Specifications and information herein are subject to change without notice.