

SYSTEM WIRING DIAGRAMS
Condenser Cooling Fan Circuit
1990 Suzuki Swift

CDR@WP.PL

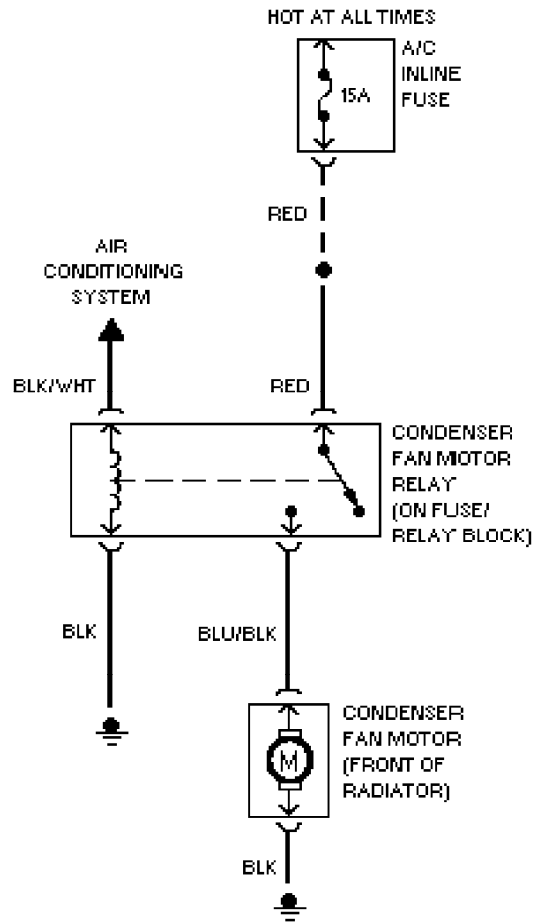

SYSTEM WIRING DIAGRAMS

Cooling Fan Circuit (p. 2)

1990 Suzuki Swift

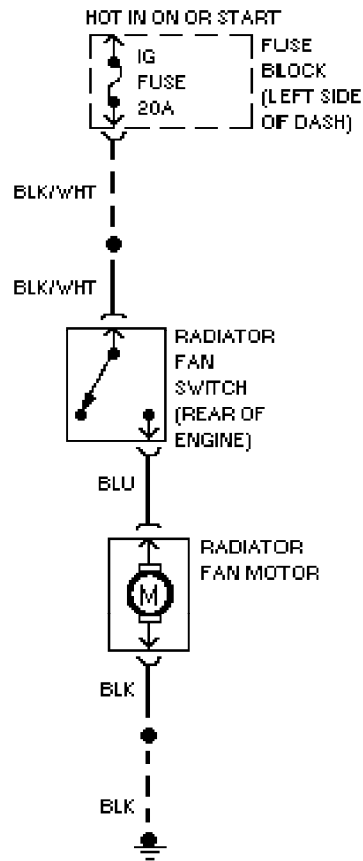

SYSTEM WIRING DIAGRAMS

Defogger Circuit (p. 3)

1990 Suzuki Swift

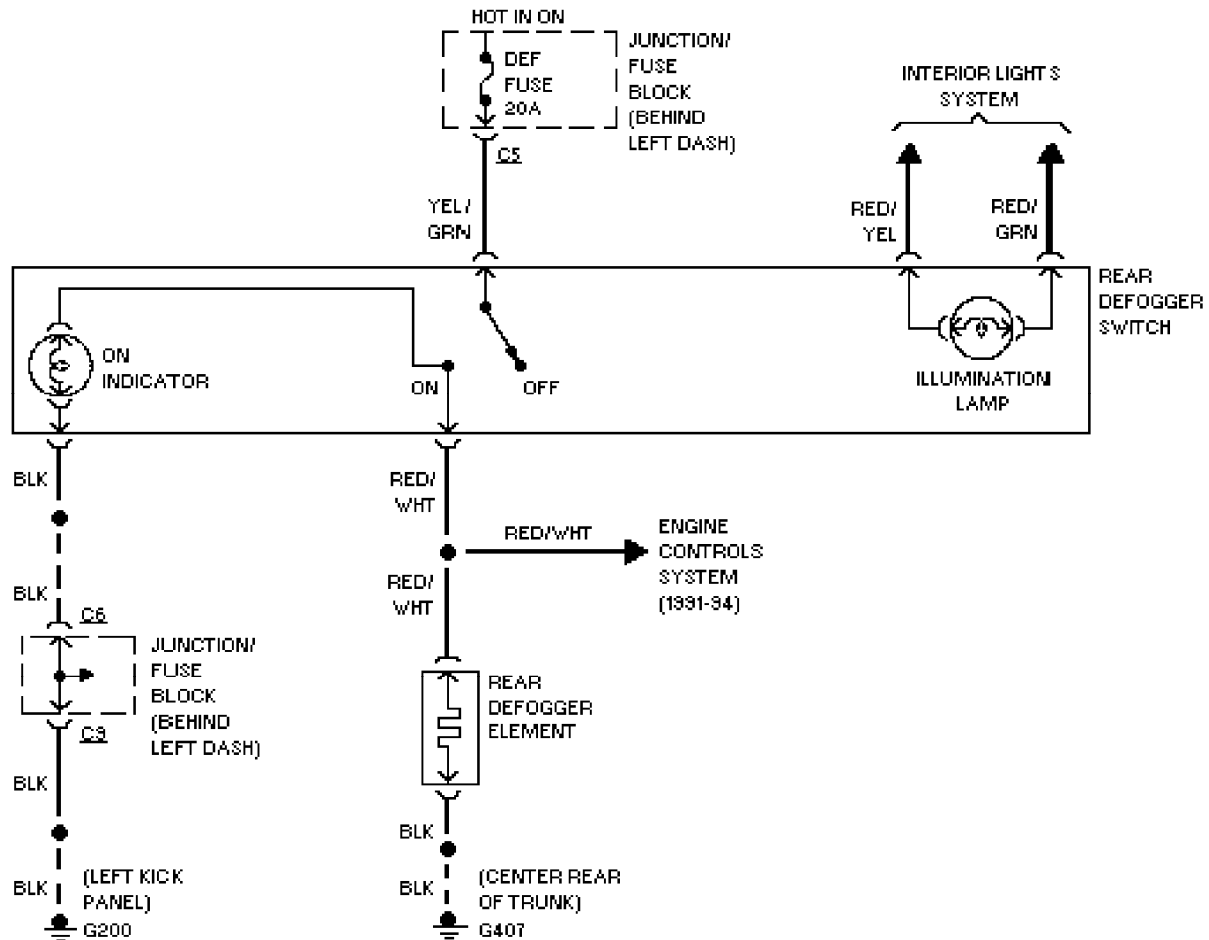

SYSTEM WIRING DIAGRAMS

Horn Circuit (p. 4)

1990 Suzuki Swift

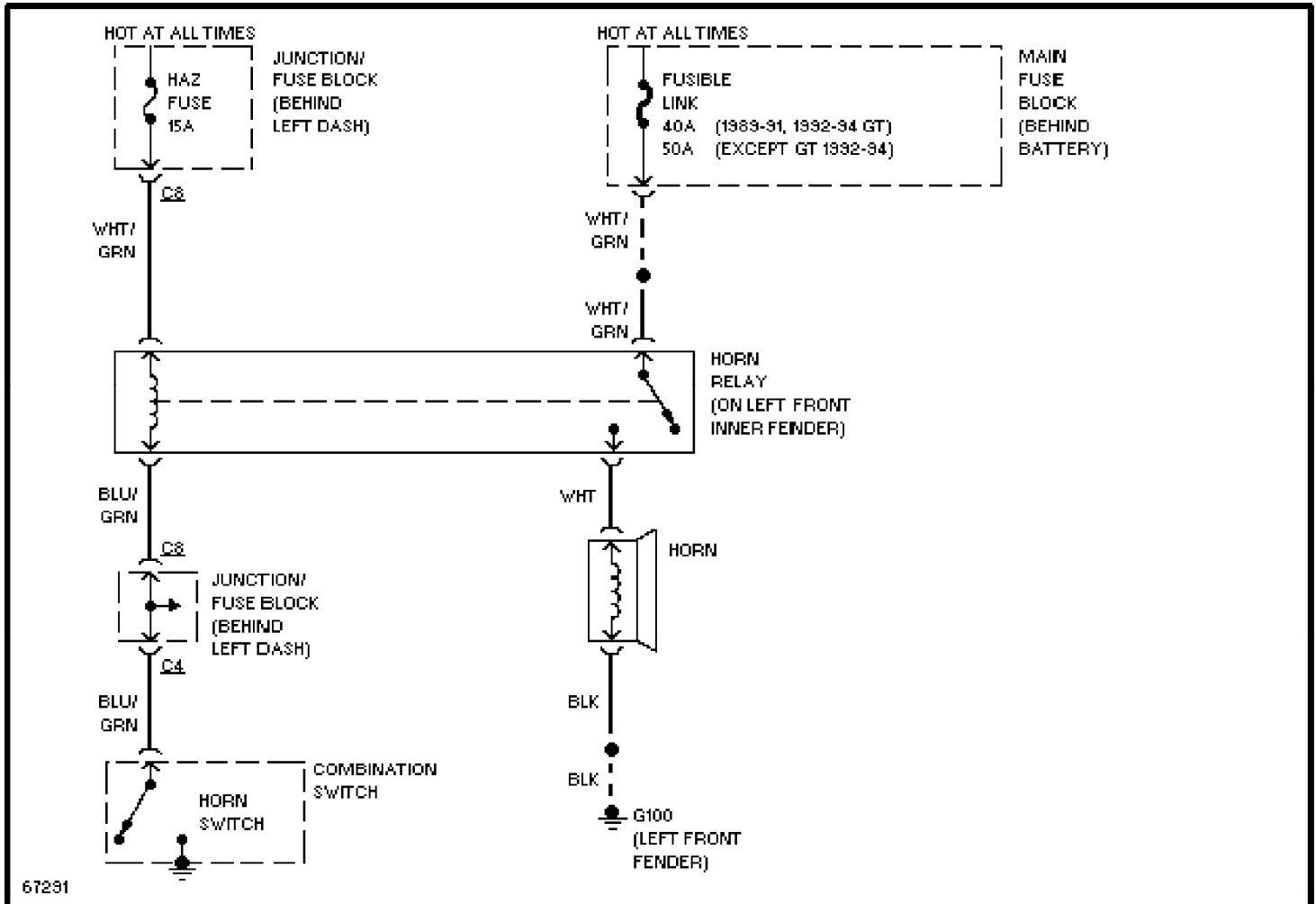

SYSTEM WIRING DIAGRAMS

Power Mirror Circuit (p. 5)

1990 Suzuki Swift

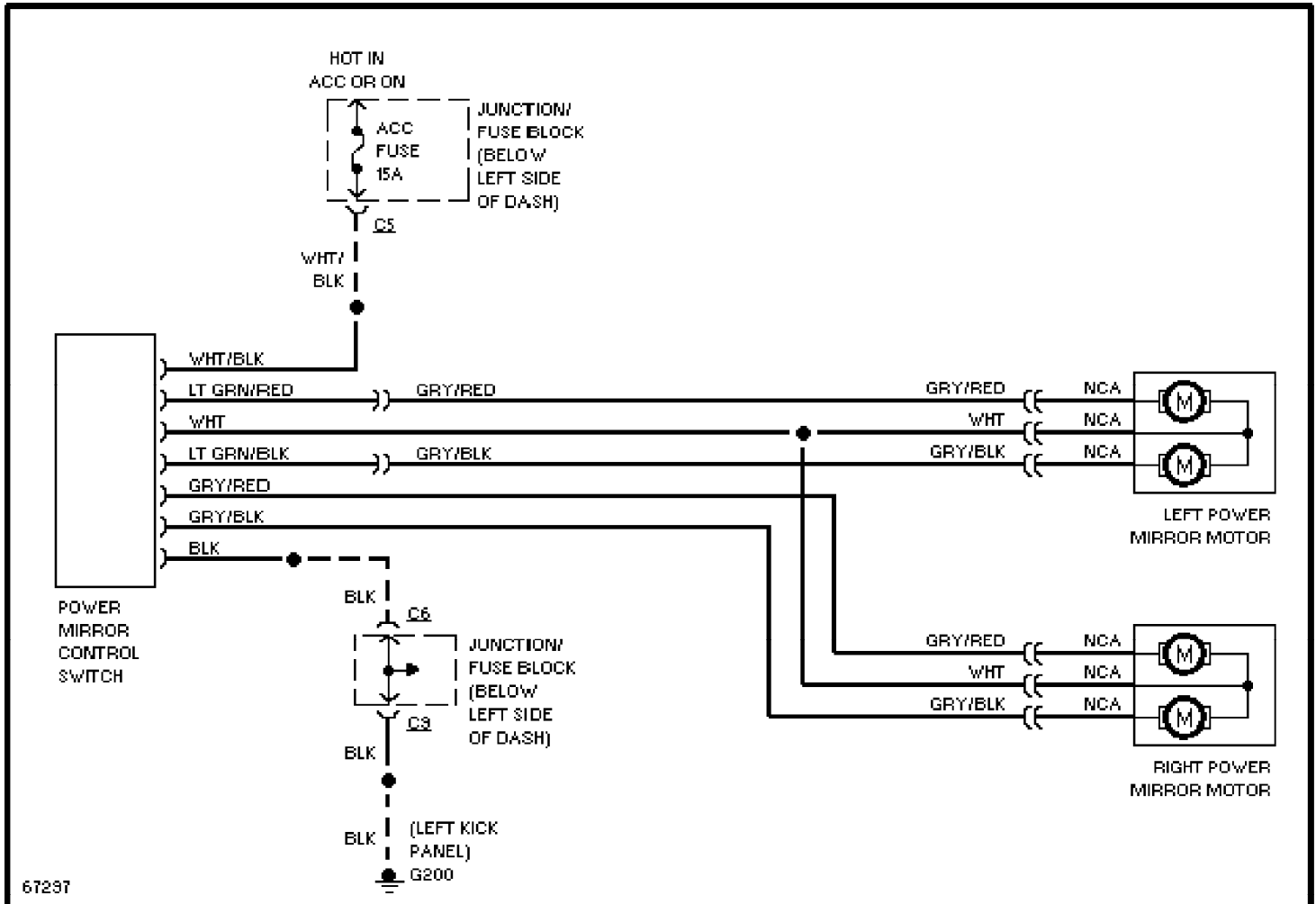

SYSTEM WIRING DIAGRAMS

Radio Circuits (p. 6)

1990 Suzuki Swift

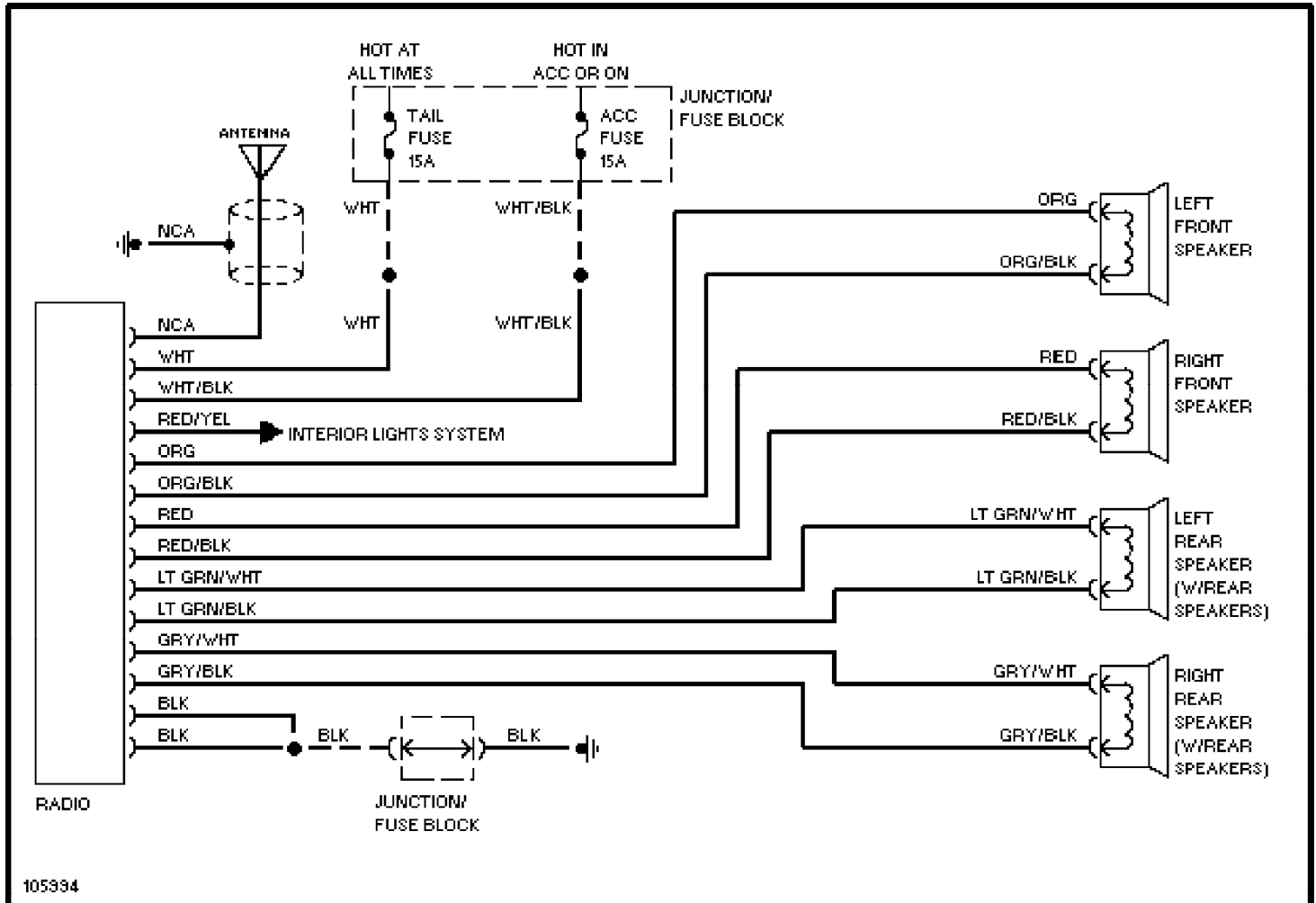

SYSTEM WIRING DIAGRAMS

Charging Circuit (p. 7)

1990 Suzuki Swift

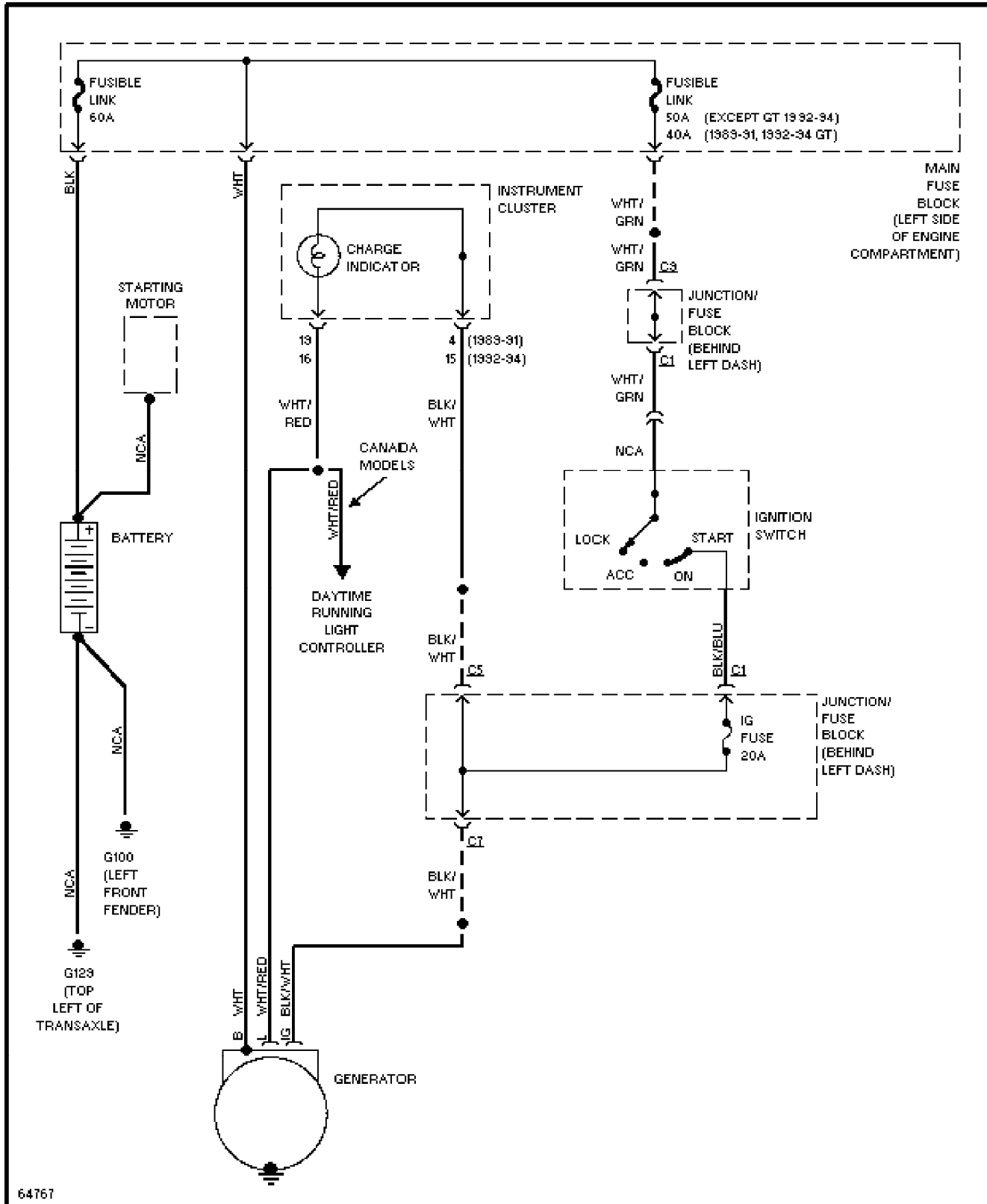

SYSTEM WIRING DIAGRAMS

Starting Circuit (p. 8)

1990 Suzuki Swift

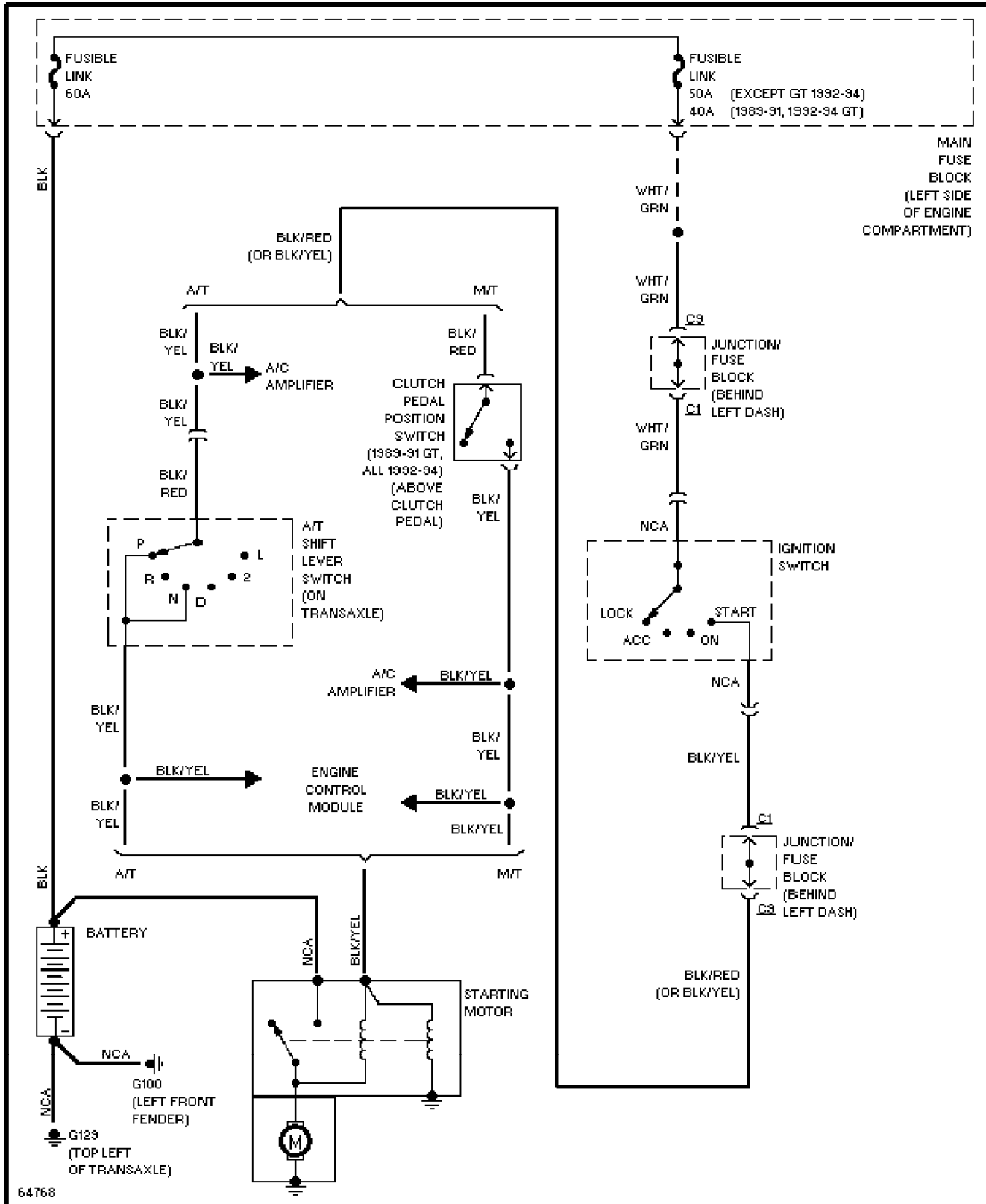

SYSTEM WIRING DIAGRAMS

Front Wiper/Washer Circuit (p. 9)

1990 Suzuki Swift

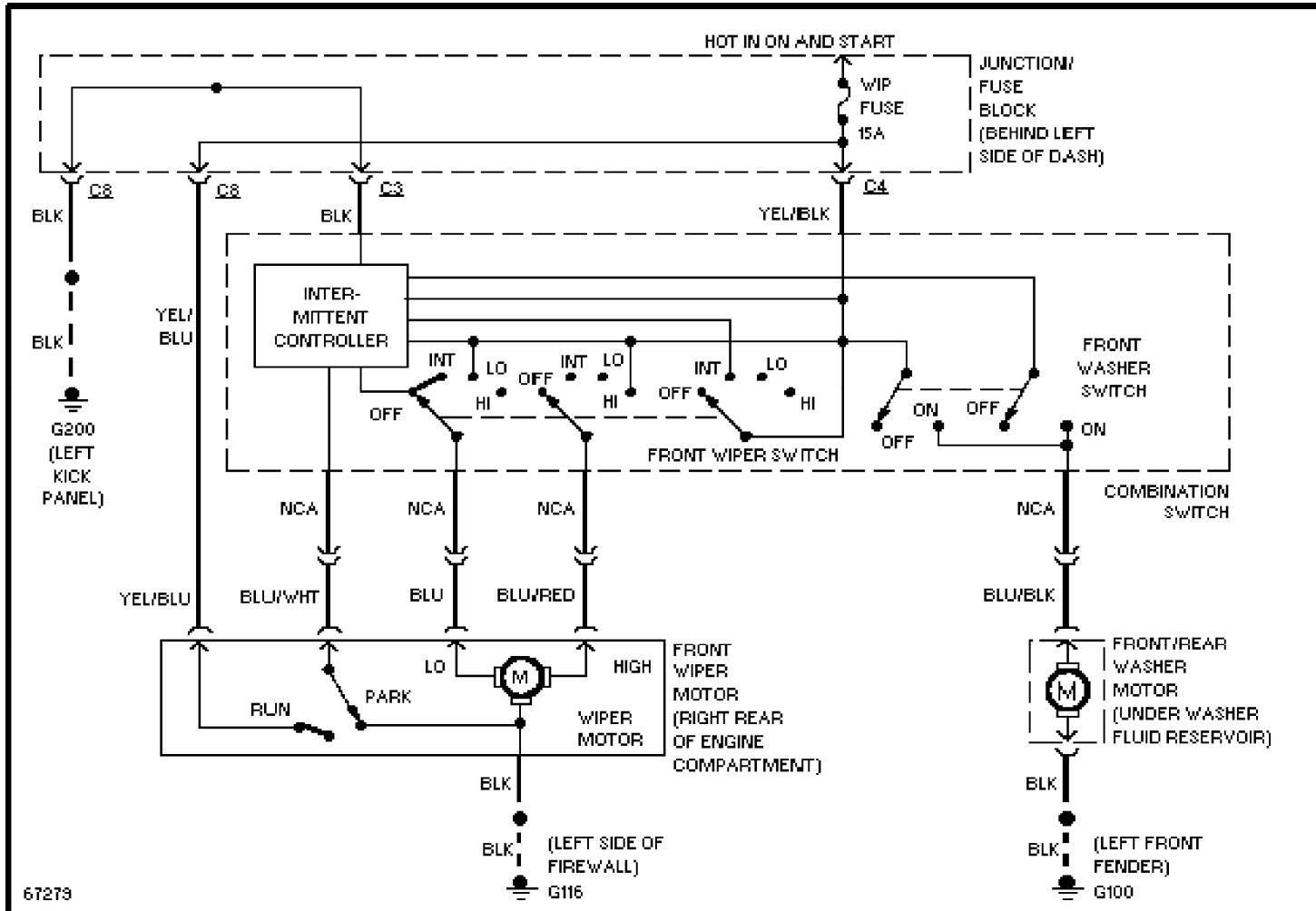

SYSTEM WIRING DIAGRAMS

Rear Wiper/Washer Circuit (p. 10)

1990 Suzuki Swift

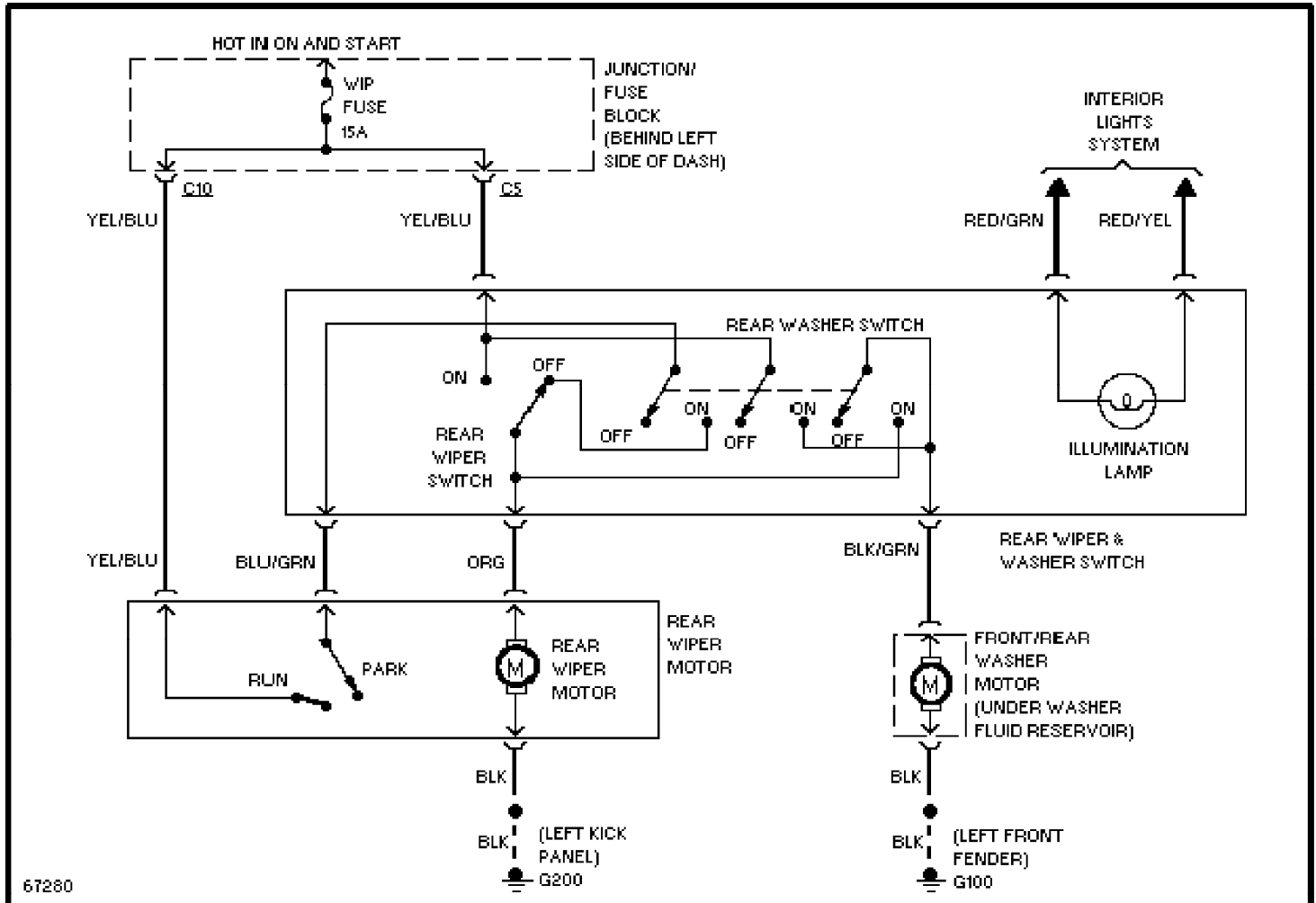

WIRING DIAGRAMS

Fig. 1: Engine Compartment & Headlights (Grid 1-3)
1990 Suzuki Swift

COMPONENT LOCATOR:

A/C AMPLIFIER	C 15-17
A/C IN-LINE FUSE	D 17
A/C SW	B 17
A/T CONTROL MODULE	A 15-18
A/T SHIFT ILLUM LTS	F 17
A/T SHIFT LOCK SOLENOID	A 18
ALTERNATOR	B 3
BACK-UP LT SW	B 22
BATTERY	A 2
BLOWER MOTOR	A 19
CIG LIGHTER	B 19
CLUTCH SW (M/T)	B 3
COMBINATION SW	C-D 18-19
DEFOG GRID	B 20
DEFOG SW	E 19
DISTRIBUTOR	D 7
DOVE LT	E 16
EFI MAIN RELAY	D 7
EFI MAIN RELAY (GTI)	A-B 11
ELECTRONIC CONTROL MODULE (ECM)	A-E 4-7
ELECTRONIC CONTROL MODULE (ECM) (GTI)	A-E 8-11
FOG LT RELAY	D 21-22
FOG LT SW	D 21-22
FRONT WIPER MOTOR	E 3
FUEL PUMP RELAY	E 7
FUEL PUMP RELAY (GTI)	D 11
FUEL TANK UNIT	D 22
FUSE BLOCK	A-E 12-16
HEATER BLOWER SW	A 19
IGNITION COIL	C 7
IGNITION COIL (GTI)	C 11
IGNITION SW	A 14
ILLUM LT RHEOSTAT	E 16
INSTRUMENT CLUSTER	B-D 20-21
LEFT DOOR SW	D 17
MAGNETIC CLUTCH RELAY	D 16-17
MAIN FUSE BOX	C 3
NEUTRAL SAFETY SW (A/T)	A 18
POWER MIRROR CTRL SW	A 20-21
RADIATOR FAN MOTOR SW	D 3
REAR WIPER MOTOR	A 23
REAR WIPER/WASHER SW	A 22
SEAT BELT SW	E 21
STARTER	A 3
STOP LT SW	C 22
TEST CONN.	D 5
TEST CONN (GTI)	D 10
WARNING BUZZER	E 20
WASHER MOTORS	E 3

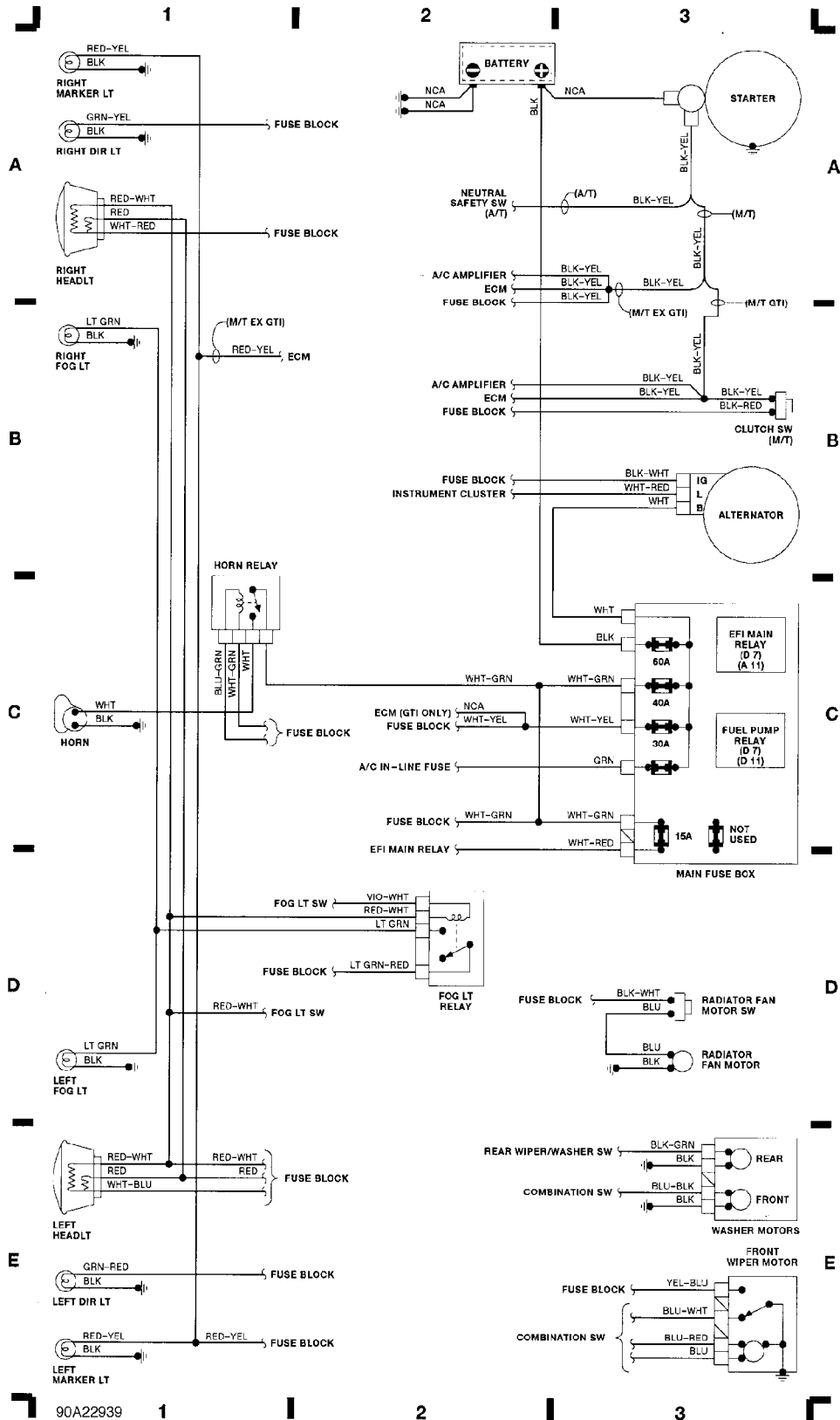

WIRING DIAGRAMS

Fig. 2: Computer Engine Control (TBI) (Grid 4-7) (p. 2)
1990 Suzuki Swift

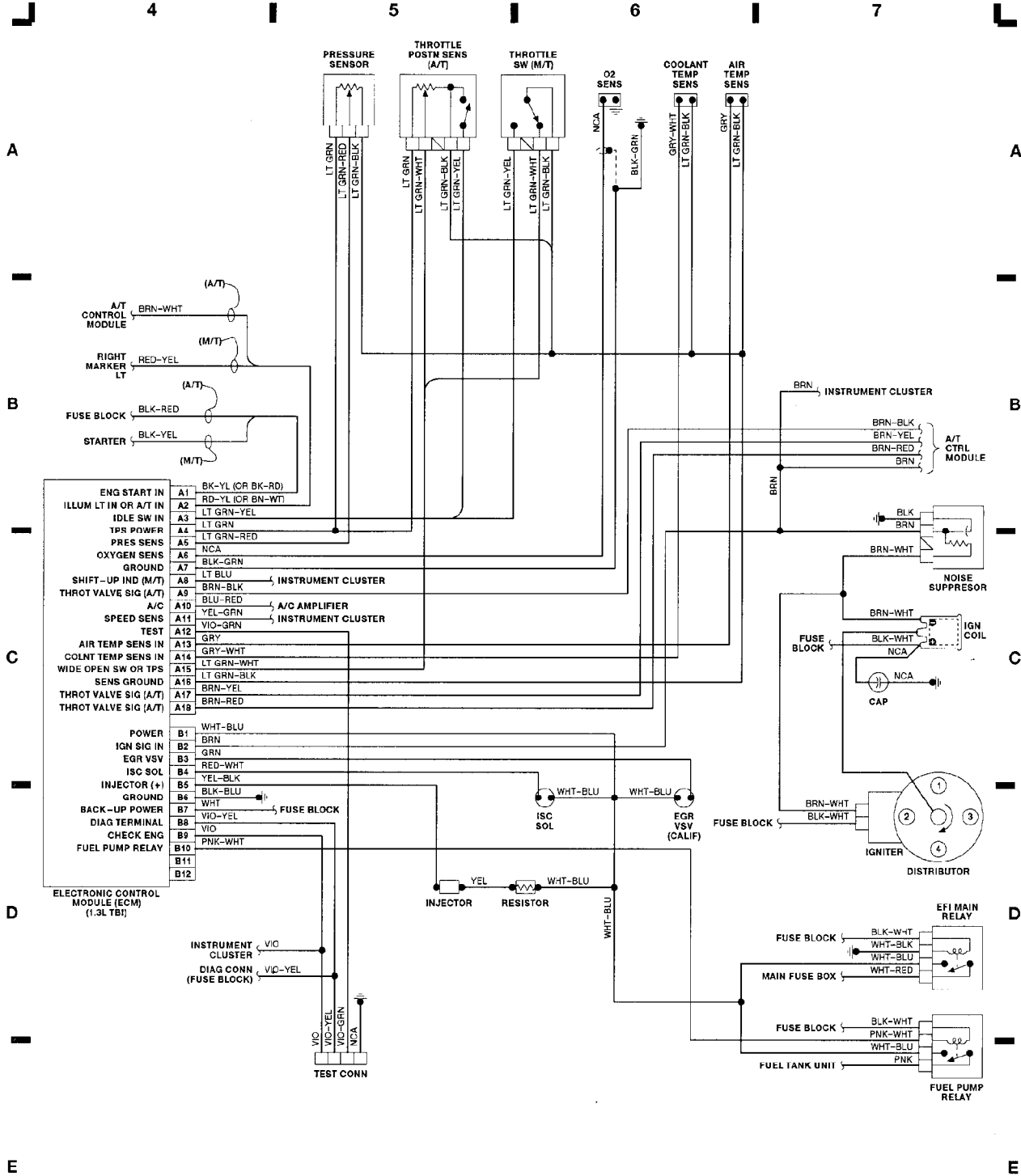

WIRING DIAGRAMS
Fig. 3: Computer Engine Control (MPFI) (Grid 8-11) (p. 3)
 1990 Suzuki Swift

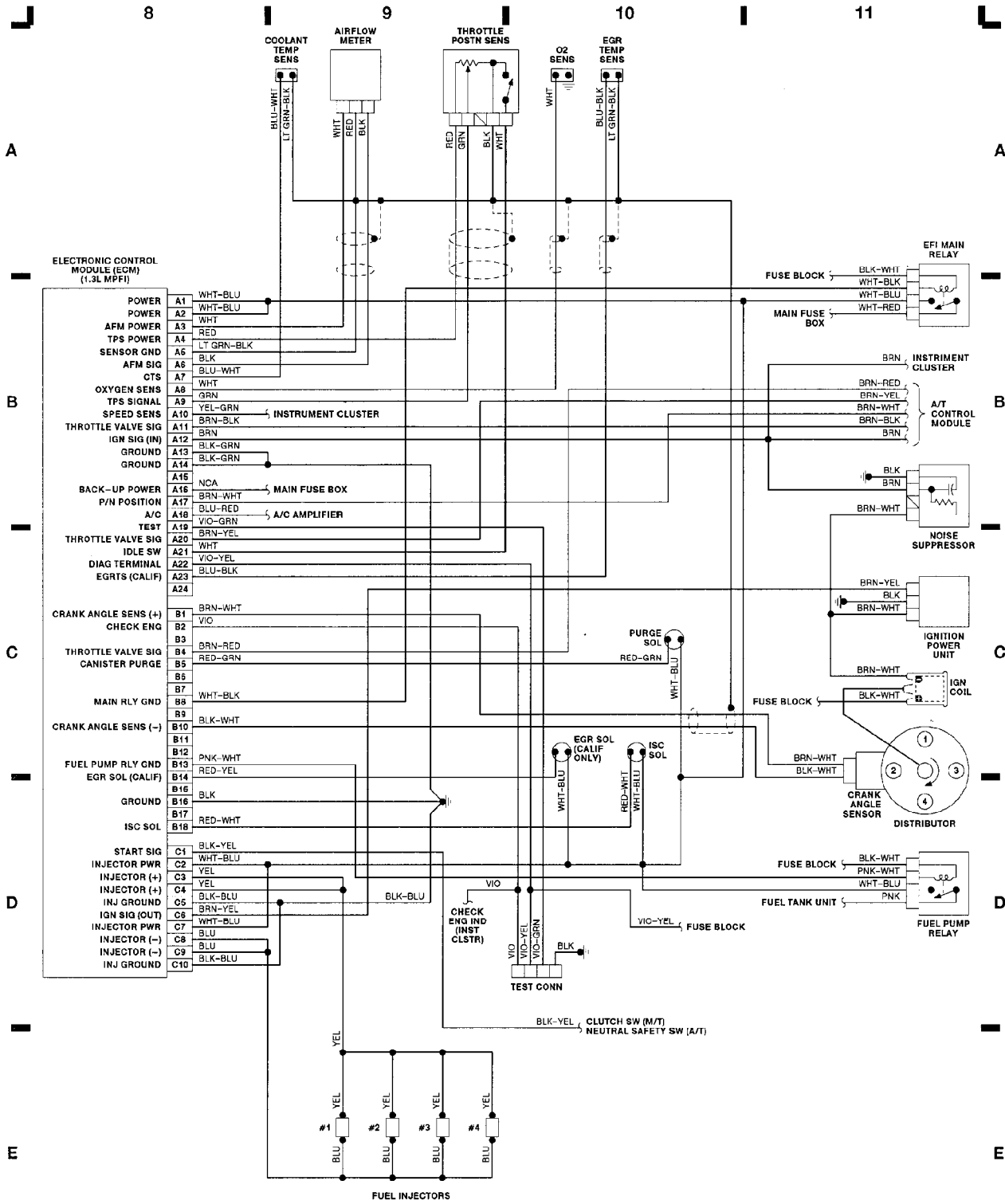

WIRING DIAGRAMS

Fig. 4: Fuse Block (Grid 12-15) (p. 4)

1990 Suzuki Swift

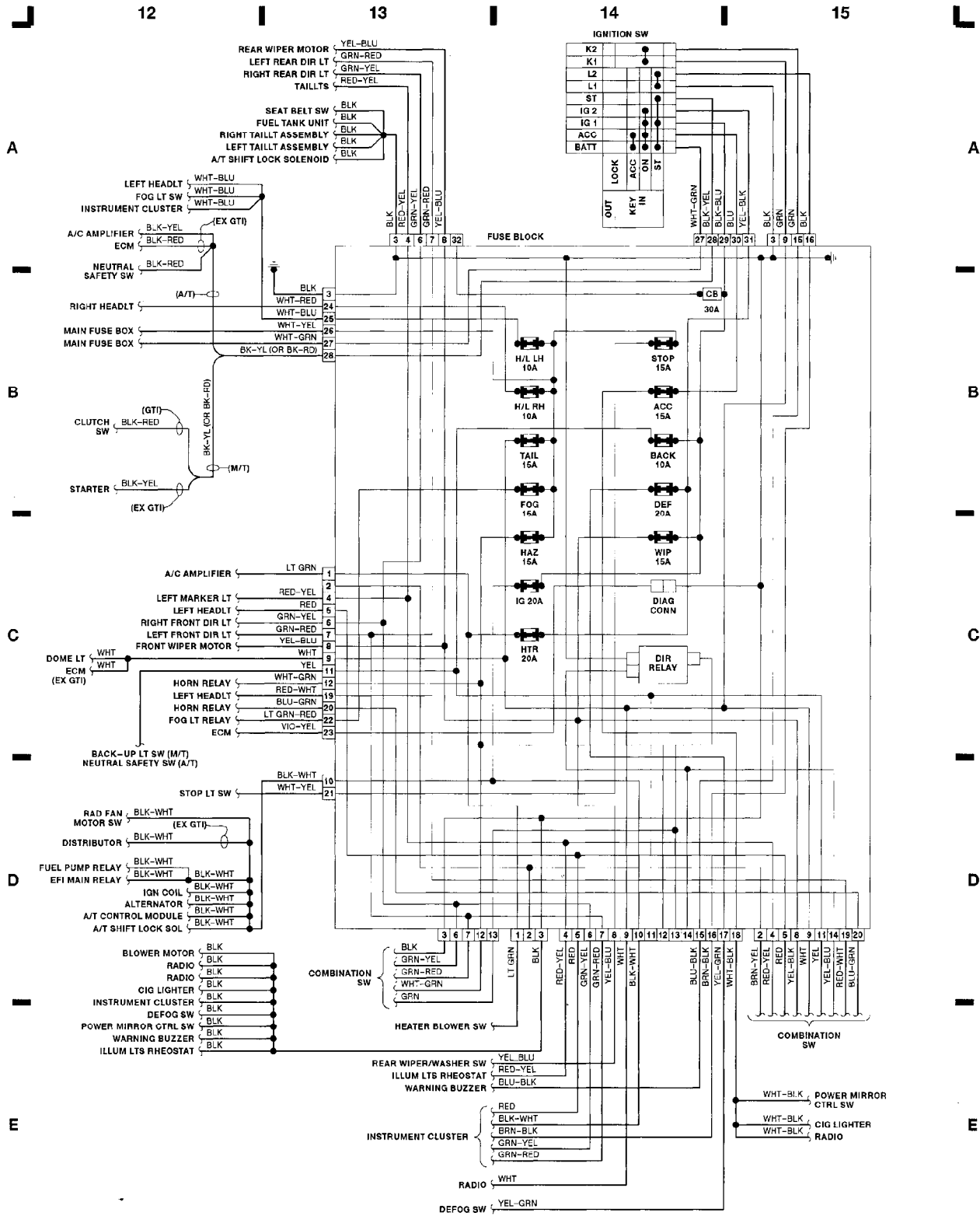

WIRING DIAGRAMS
Fig. 5: A/C & Heater, Comb Switch (Grid 16-19) (p. 5)
 1990 Suzuki Swift

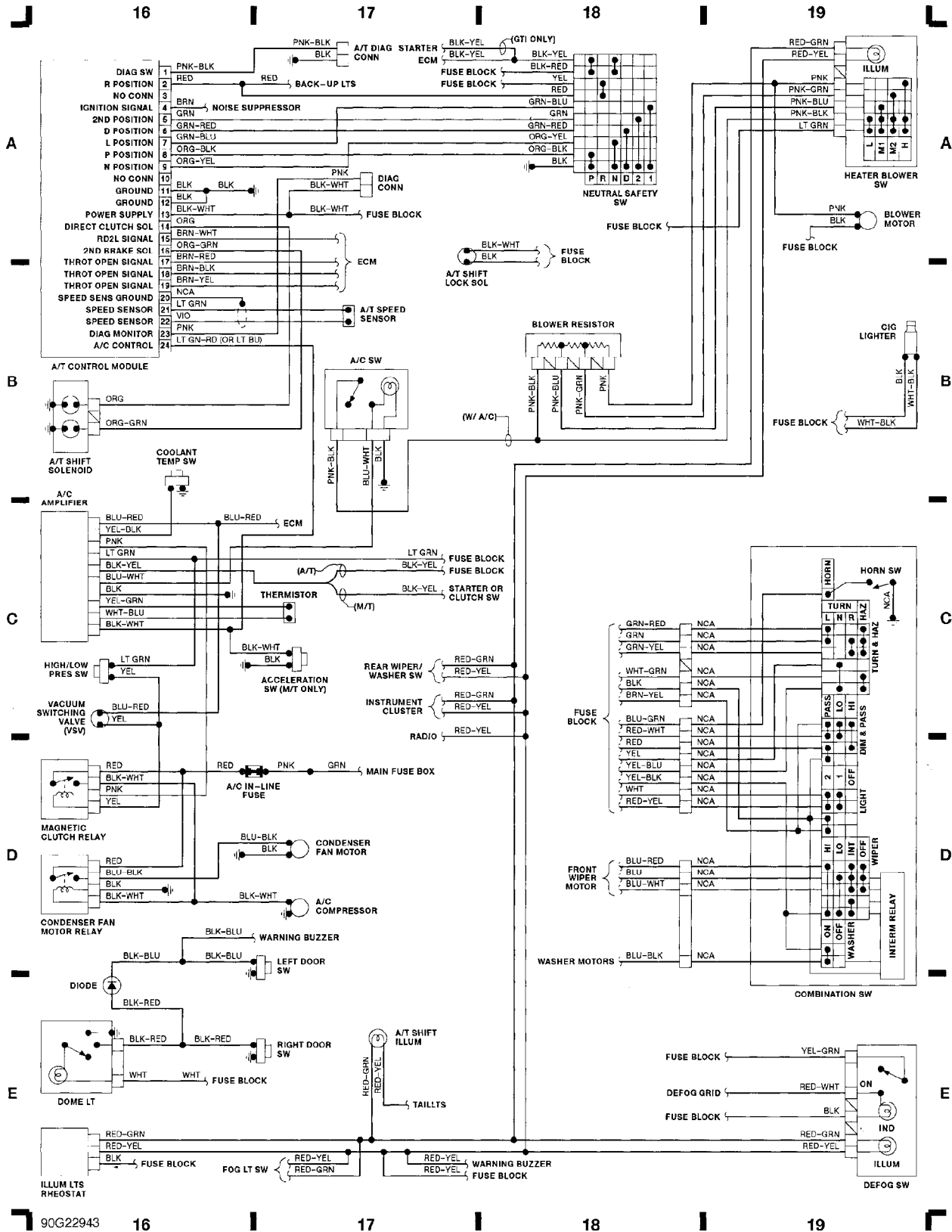

WIRING DIAGRAMS

Fig. 6: Instrument Panel, R Wiper/Washer Taillights (Grid 20-23) (p. 6)
1990 Suzuki Swift

