

# Roadstar DVD-2010H

---

***SERVICE MANUAL***

---

## 1. GENERAL DESCRIPTION

Major functional blocks are discussed briefly in this section. A more detailed description is contained later in the document.

### 1.1 STi5519

The STi5519 provides a highly integrated back-end solution for DVD applications. A host CPU handles both the general application (the user interface, and the DVD, CD-DA, VCD, SVCD navigation) and the drivers of the different embedded peripheral (audio/video, sub-picture decoders, OSD, PAL/NTSC encoder...)

#### **These functions include:**

Integrated 32-bit host CPU @ 60MHz

- 2 Kbytes of instruction cache, 2 Kbytes of data cache, and 4Kbytes of SRAM configurable as data cache.

Audio decoder

- 5.1 channel Dolby Digital® /MPEG-2 multi-channel decoding, 3 X 2-channel PCM outputs

- IEC60958 - IEC61937 digital output

- DTS® digital out 5.1 channel

- SRS®/TruSurround®

- MP3 decoding

Video decoder

- Supports MPEG-2 MP@ML

- Fully programmable zoom-in and zoom-out

- PAL to NTSC and NTSC to PAL conversion

DVD and SVCD subpicture decoder

High performance on-screen display

- to 8 bits per pixel OSD options

- Anti-flicker, anti-flutter and anti-aliasing filters

PAL/NTSC/SECAM encoder

- RGB, CVBS, Y/C and YUV outputs with 10-bit DACs

- Macrovision® 7.01/6.1 compatible

Shared SDRAM memory interface

- Supports one or two 16Mbit, or one 64Mbit 125 MHz SDRAMs

Programmable CPU memory interface for SDRAM, ROM, peripherals...

Front-end interface

- DVD, VCD, SVCD and CD-DA compatible

- Serial, parallel and ATAPI interfaces

- Hardware sector filtering

- Integrated CSS decryption and track buffer

Integrated peripherals

- UARTS, 2 SmartCards, I2C controller, 3 PWM outputs, 3 capture timers

- Modem support

- 38 bits of programmable I/O

Please refer to the STi5519 Data Sheets: STi5519 DVD HOST PROCESSOR WITH ENHANCED AUDIO FEATURES and STi5519 REGISTER MANUAL for more detailed information.

### 1.2 MEMORY

The STi5519 includes all of the interface signals to connect to industry standard SDRAM, DRAM, ROM, and I2C memory devices. The system includes one or two SDRAM components. The MPEG decoder unit interfaces to a single 4M x 16bit SDRAM over the SMI bus. The general purpose processor can share the decoder SDRAM or can access an optional SDRAM installed on the EMI bus. This EMI SDRAM can be either a 1Mx16 or 4Mx16 chip. The optional EMI SDRAM can be installed if the system requires higher performance or requires more RAM than is standard system (due to complex trick modes, advanced GUI, etc). The standard production executes without EMI SDRAM

installed, A single 1Mx16 FLASH ROM device is support on the EMI bus. There is also a 2kb I2C serial EEPROM for storage of user player settings, software configuration information, title specific information, or other purposes.

### **1.3 DRIVE INTERFACES**

The system supports a standard ATAPI drive interface.

The interface to the ATAPI drive is included within the STi5519. The ATAPI data bus is buffered so that the ATAPI cable does not interfere with signal quality. An ATAPI drive is connected via the standard 34 pin dual row PC style IDE header

### **1.4 FRONT PANEL**

The front panel is based around an Futaba VFD and a common NEC front panel controller chip, (uPD16311). The STi5519 controls the uPD16311 using several control signals, (clock, data, chip select). The infra-red remote control signal is passed directly to the STi5519 for decoding.

### **1.5 OUTPUTS**

There is no separate rear panel for outputs. They are embedded into the mainboard. Supported outputs are:

- Six channel or two channel audio outputs
- Optical and coax S/PDIF outputs are supported
- Composite, S-Video, and SCART outputs

The six video signals used to provide CVBS, S-Video, and RGB are generated by the STi5519's internal video DAC. The video signals are be buffered by external circuitry.

Six channel audio output by the STi5519 in the form of three I2S (or similar) data streams. The S/PDIF serial stream is also generated by the STi5519. Three pieces two-channel audio DACs (CS4335) are used for six channel audio output, and similarly only one CS4335 DAC is used for two channel audio output.

## **2 GPIO, IRQ, AND CHIP SELECT ASSIGNMENTS**

PIO Port Bit Pin # STi5519 Alternate Function Software Function

# Pin data

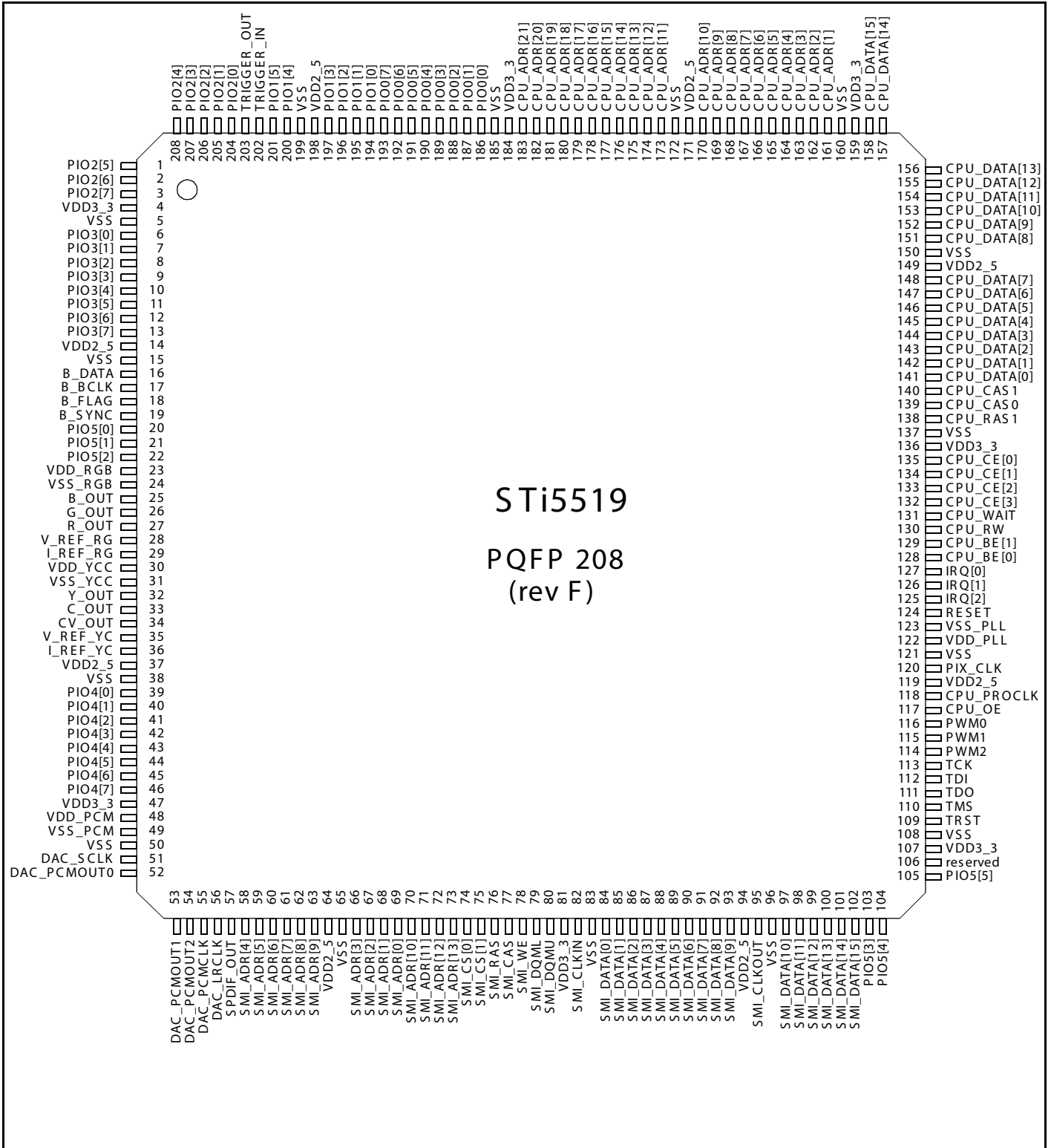

PIO Port Bit	Pin #	STi5519 Alternate Function	CineMaster CE Function
Port 0 Bit 0	186	SC0_DATA	#SOFT_RESET
Port 0 Bit 1	187	#ATAPI_RD	#ATAPI_RD
Port 0 Bit 2	188	#ATAPI_WR	#ATAPI_WR
Port 0 Bit 3	189	SC0_CLK	DAC_CCLK (Audio DAC control)
Port 0 Bit 4	190	SC0_RST	DAC_CDTI (Audio DAC control)
Port 0 Bit 5	191	SC0_CMD_VCC	#DAC_CS0 (Audio DAC control)
Port 0 Bit 6	192	SC0_DATA_DIR	#DAC_CS1 (Audio DAC control)
Port 0 Bit 7	193	SC0_DETECT	Unused (Test Point 39)
Port 1 Bit 0	194	SSC0_DATA	SDA (I2C)
Port 1 Bit 1	195	SSC0_CLK	SCL (I2C)
Port 1 Bit 2	196	PARA_DVALID/SC_EXT_CLK	Unused (Test Point 35)
Port 1 Bit 3	197	TXD2	TXD (Serial Port)
Port 1 Bit 4	200	RXD2	RXD (Serial Port)
Port 1 Bit 5	201	PARA_SYNC/TXD1	SR0 (for PLL1700)
Port 1 Bit 6	202	TRIGIN	TRIGIN (JTAG)
Port 1 Bit 7	203	TRIGOUT	TRIGOUT (JTAG)
Port 2 Bit 0	204	SC1_DATA	FPCLK (Front Panel)
Port 2 Bit 1	205	PARA_REQ/RXD1	FS0 (for PLL1700)
Port 2 Bit 2	206	PARA_STR	FS1 (for PLL1700)
Port 2 Bit 3	207	SC1_CLK	RTS (Serial Port)
Port 2 Bit 4	208	SC1_RST	CTS (Serial Port)
Port 2 Bit 5	1	SC1_CMD_VCC	FPDATA (Front Panel)
Port 2 Bit 6	2	DAC_DATA/SC1_DATA_DIR	DAC_DATA (Stereo Audio)
Port 2 Bit 7	3	SC1_DETECT	FPSTRB (Front Panel)
Port 3 Bit 0	6	PARA_DATA0	OPEN (TMM Tray Control)
Port 3 Bit 1	7	PARA_DATA1	CLOSE (TMM Tray Control)
Port 3 Bit 2	8	PARA_DATA2	Unused (Test Point 36)
Port 3 Bit 3	9	PARA_DATA3	Front Panel IR
Port 3 Bit 4	10	PARA_DATA4	Unused (Test Point 37)
Port 3 Bit 5	11	PARA_DATA5	Unused (Test Point 38)
Port 3 Bit 6	12	PARA_DATA6/COMP1	#SENSE (TMM Tray Control)
Port 3 Bit 7	13	PARA_DATA7/COMP2	#PUSH (TMM Tray Control)
Port 4 Bit 0	39	YUV0	YUV0 (External Video DENC)
Port 4 Bit 1	40	YUV1	YUV1
Port 4 Bit 2	41	YUV2	YUV2
Port 4 Bit 3	42	YUV3	YUV3
Port 4 Bit 4	43	YUV4	YUV4
Port 4 Bit 5	44	YUV5	YUV5
Port 4 Bit 6	45	YUV6	YUV6
Port 4 Bit 7	46	YUV7	YUV7

\* Front Panel uses the 16311 controller. In the CineMaster design, FPDIN and FPDOOUT are connected together as FPDATA.

### **3. AUDIO OUTPUT**

The STi5519 supports a six channel analog output. In a system configuration with six analog outputs, the front left and right channels can be configured to provide the stereo (2 channel) outputs and Dolby Surround, or the left and right front channels for a 5.1 channel surround system.

The STi5519 also provides digital output in S/PDIF format. The board supports both optical and coaxial S/PDIF outputs.

#### **3.1 AUDIO DACs**

The STi5519 supports several variations of an I<sup>2</sup>S type bus, varying the order of the data bits (leading or no leading zero bit, left or right alignment within frame, and MSB or LSB first) is possible using the STi5519 internal configuration registers. The I<sup>2</sup>S format uses four stereo data lines and three clock lines. The I<sup>2</sup>S data and clock lines can be connected directly to one or more audio DAC to generate analog audio output.

The two-channel DAC is an Cirrus Logic CS4335. The DACs support up to 96kHz sampling rate.

The outputs of the DACs are differential, not single ended so a buffering circuit is required. The buffer circuits use National LM833 op-amps to perform the low-pass filtering and the buffering.

### **4 VIDEO INTERFACE**

The STi5519 integrates a PAL/NTSC encoder. It converts the digital MPEG/Sub Picture/OSD stream into a standard analog baseband PAL/NTSC signals. Six analog video outputs provide CVBS, Svideo (Y/C), and RGB formats. The three RGB signals can be configured via an internal STi5519 register setting.

The encoder handles interlaced and non-interlaced mode. It can perform Closed Captions, CGMS or Teletext encoding and allows Macrovision 7.01/6.1 copy protection. The encoder supports both master and slave modes for synchronization.

The buffered CVBS video is available on a RCA (cinch) style jack, S-Video on a mini-DIN and all six signals (and stereo audio) are available on a SCART connector.

### **5 MPEG DECODER SDRAM MEMORY**

The STi5519 includes glueless interfaces to SDRAM memory for the MPEG decoder. The STi5519 supports one or two 1Mx16bit chips or a 4Mx16bit SDRAM chip. However, the board supports only a 64Mbit chip. The device used is a 4M x 16 bit, 125MHz, 3.3V, 54 pin TSOP II, Micron Technology MCT48LC4M16A2TG-7 or equivalent.

### **6 FLASH MEMORY**

The decoder board supports a single 1Mx16bit FLASH memory device. The device is a 1M x 16, 90ns, bottom boot block, 3.3V, 48 pin TSOP II, 29F800 or equivalent.

### **7 SERIAL EEPROM MEMORY**

An I2C serial EEPROM is used to store user configuration (i.e. language preferences, speaker setup, etc.) and software configuration information (i.e. remote control type). Industry standard EEPROM range in size from 1kbit to 256kbit and share the same IC footprint and pinout. The default device is 2kbit, 256x 8, SOIC8 SGS Thomson ST24C02M1 or equivalent.

### **8 ATAPI DRIVE INTERFACE**

The STi5519 includes a glueless ATAPI interface on-chip. While this interface limits performance of the system, it is a lower cost solution than providing external logic to interface the drive to the STi5519 frontend interface.

Note: The decoder board supports the standard ATAPI electrical connections, but the software protocol within the drive is not always supported according to ATAPI specifications. Custom software may need to be developed and tested to support ATAPI drives from different manufacturers.

## 9 AUDIO SAMPLING RATE AND EXTERNAL PLL COMPONENT CONFIGURATION

The decoder board has optional PLLs, which can be installed to provide the audio clock for the system. The initial version of the STi5505 was not able to provide an audio clock for 96kHz support and an external PLL was used to support this. This was fixed in the STi5505 later chip revisions and therefore no problems are expected in the STi5519. However, in case a problem arises, the PLL circuit can be installed to provide a high quality clock – particularly important in S/PDIF applications.

In the default configuration, a small buffer chip is installed to buffer the audio clock between the STi5519 and the audio DACs.

## 10 FRONT PANEL

### 10.1 VFD CONTROLLER

The VFD controller is a NEC uPD16311. This controller is not a processor, but does include a simple state machine which scans the VFD and reads the front panel button matrix. The 16311 also includes RAM so it can store the current state of all the VFD icons and segments. Therefore, the 16311 need only be accessed when the VFD status changes and when the button status is read. The STi5519 can control this chip directly using PIO pins or can allow the front panel PIC to control the VFD.

## 11 MISCELLANEOUS FUNCTIONS

### 11.1 RESET CIRCUITRY

Two different chips are supported to provide the power-on-reset and pushbutton reset function: Telcom Semiconductor TC1270, or Dallas DS1811.

### 11.2 VOLTAGE REGULATORS

There are two +5V linear regulators to generate +5V for the analog circuitry from +12V. A smaller DPAK surface mount device can be used in most circumstances, but in applications where more than 150mA are required, a TO-220 through-hole package can be used.

The STi5519 requires 2.5V to operate. This voltage is generated from +5V.

## 12 CONNECTORS

### 12.1 ATAPI DRIVE STANDARD CONNECTOR

### 12.2 STi5519 JTAG INTERFACE

### 12.3 SCART CONNECTORS

### 12.4 POWER CONNECTOR

## 13. VESTEL DVD DECODER CIRCUIT DESCRIPTION

### 13.1 POWER SUPPLY:

- Socket PL1 is the 220VAC input.
- Socket PL4 is used for the power button on the front panel.
- 2.5A fuse F1 is used to protect the device against short circuit.
- Line filters and capacitors TR2, C2, TR4 and C3 are used to block the parasitic coming from the mains. They also prevent the noise, produced in the circuit, from being injected to the line.
- Voltage is rectified by using diodes D1, D5, D6 and D4. Using capacitor C1 (100µf) a DC voltage is produced. (310- 320VDC).

- The current in the primary side of the transformer TR3 comes to the SMPS IC (IC3 TOP223Y). The SMPS IC has a three-pin TO-220 case and a cooler is mounted on it. It has a built-in oscillator, overcurrent and overvoltage protection circuitry and runs at 100kHz. It starts with the current from the primary side of the transformer and follows the current from the feedback winding.
- Feedback current is rectified with diode D7 and filtered with capacitor C4 and enters the optocoupler IC2 (CQY80NG). Depending on the control current coming from the secondary side, SMPS IC keeps the output voltage constant by controlling the duty cycle of the 100kHz signal (PWM) at the primary side of the transformer.
- Voltages on the secondary side are as follows: -12 Volts at D8, 5 Volts at D9, 15 Volts at D10, -22 Volts at D13.
- Using resistors R5, R4 and R27, 5V output is divided properly for D14 operation.
- D14 TL431 is a constant current regulator. TL431 watches the 5 volts and supplies the required current to IC2. There are a LED and a photo transistor in IC2. The LED inside the IC2 transmits the value of the current from D14 to phototransistor. Depending on the current gain of the phototransistor IC3 keeps the voltage on the 5-volt-winding constant.
- Adjustable voltage regulator IC5 (LM317) supplies 12 Volts. 12 Volts is obtained by using resistors R19, R20 and R21.
- When the device enters stand-by mode, transistor Q2 starts to conduct and pulls the adjust pin of IC5 to ground, where this cuts 12Volts off.
- IC6 is also an LM317 that produces 3.3 Volts output from its 5 volts input.
- -22 Volts is used to feed the VFD (Vacuum Fluorescent Display) driver IC on the front panel. Using diode D17 -22V is decreased about 5.6V and connected to the filament winding to produce the DC offset for the filaments.
- Transistor Q3 and zener diode D18 are used to regulate +12 Volts. This voltage is used to feed op-amps on the back panel.

# TOP221-227

## TOPS witch -II family

### Three-terminal off-line PWM MS witch

#### Product Highlights

- Lowest cost, lowest component count switcher solution
- Cost competitive with linears above 5W
- Very low AC/DC losses up to 90% efficiency
- Built-in Auto-restart and Current limiting
- Latching Thermal shutdown for system level protection
- Implements Flyback, Forward, Boost or Buck topology
- Works with primary or opto feedback
- Stable in discontinuous or continuous conduction mode
- Source connected tab for low EMI
- Circuit simplicity and Design Tools reduce time to market

#### Description

The second generation *TOPSwitch-II* family is more cost effective and provides several enhancements over the first generation *TOPSwitch* family. The *TOPSwitch-II* family extends the power range from 100W to 150W for 100/115/230 VAC input and from 50W to 90W for 85-265 VAC universal input. This brings *TOPSwitch* technology advantages to many new applications, i.e. TV, Monitor, Audio amplifiers, etc. Many significant circuit enhancements that reduce the sensitivity to board layout and line transients now make the design even

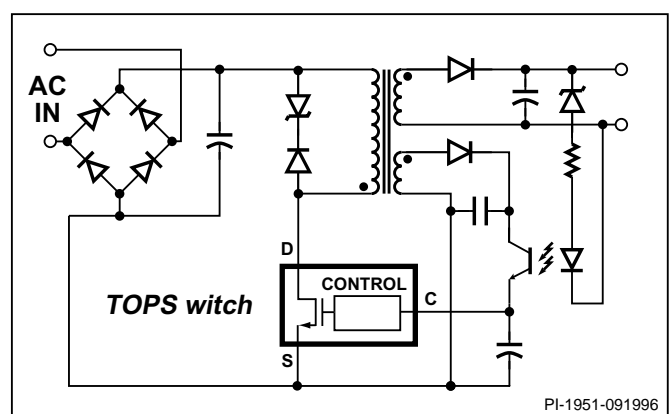

Figure 1. Typical Flyback Application.

easier. The standard 8L PDIP package option reduces cost in lower power, high efficiency applications. The internal lead frame of this package uses six of its pins to transfer heat from the chip directly to the board, eliminating the cost of a heat sink. *TOPSwitch* incorporates all functions necessary for a switched mode control system into a three terminal monolithic IC: power MOSFET, PWM controller, high voltage start up circuit, loop compensation and fault protection circuitry.



## 13.2 FRONT PANEL:

- All the functions on the front panel are controlled by U1 (Sti5519) on the mainboard.
- U1 sends the commands to IC2 uPD16311 via socket PL1 (pins 3,4 and 5).
- There are 16 keys scanning function, 2 LED outputs, 1 Stand-by output and VFD drivers on IC2.
- Pin 52 is the oscillator pin and is connected via R5 56K.
- LED D6 is red in stand-by mode and green when the device is on. When entering stand-by mode, pin 48 goes HIGH (+5V) and controls the transistor Q2 on the power board.
- Vacuum fluorescent display MD2 is specially designed for DVD.
- The scanned keys are transmitted via IC2 pin 5 and 6 to U1 on the mainboard.
- IR remote control receiver module IC3 (TSOP1836) sends the commands from the remote control directly to U1.
- Socket PL2 carries the VFD filament voltage and -22 Volts.

## 13.3 Outputs:

- There are 1 SCART connector (PL5), 6 pieces RCA audio jacks JK1, for audio output, 1 coaxial digital audio output JK3 and 1 laser digital audio output MD1 on the back panel.
- TOTX178 is used for laser output.
- SPDIF enters the pins 1,3,5,9, and 11 of IC25. Connecting gates in parallel a buffer is constructed. C166 is used for DC coupling. Resistors R181 and R182 divide the signal, which is transmitted out via JK3 (RCA jack)
- Audio outputs are on JK1.
- Q145 through Q148 are used to suppress the noises during turn on and turn off.
- There are two op-amps in each IC18, IC19 and IC20 and they are used for six audio channels. IC18 is used for front channels, Resistors R137, R190 and R158 are used to adjust the gain and using R156 and C116 a filter circuit is created for the left channel. For front right channel, these components are R140, R191 and R149 for gain, R151 and C113 for filter. For the remaining four channels IC19 and IC20 are used with the corresponding resistors and capacitors connected in similar way.
- Op-amp outputs the front left audio via C124 and R162 to RCA jack and via C123 and R161 to SCART. Front right audio is sent to RCA its jack via C127, R164 and sent to SCART via C126 and R163.
- SCART pin 8 is controlled using transistors Q21 and Q22 to switch between modes 4:3 and 16:9 .
- When the BPPIO0 becomes 5 Volts, 4:3 mode is selected and 16:9 mode is selected when this output becomes 0. The circuit is adjusted to output 12 Volts for 4:3 mode and 6 Volts for 16:9 mode.
- Transistors Q26 and Q24 transmits these voltages when the device is turned on and cuts them off when the unit is turned off.
- LUMA and CHROMA signals of S-Video are transmitted to JK4 (S-Video socket) via transistors Q12 and Q13 respectively.

**SPARE PART LIST**

**ZCHMP3-3000**

COMPONENT CODE	MATERIAL	UNIT	QTY	POSITION NUMBER				
20071874	MAINBOARD CHS. DVD-3000 (MAN) DVS-2CH	PC	1.000	.	.	.	.	.
20071876	POWER BOARD CHS. DVD-3000 (MAN)/(508-DVS)	PC	1.000	.	.	.	.	.
20092998	SCART ASSY DVD-3000 (MAN) (FERRITE)	PC	1.000	.	.	.	.	.
20100796	FRONT PANEL DVD3000 (MAN) (SC FERRITE)	PC	1.000	.	.	.	.	.
30000158	CAP MKP 4.7NF 630V J	PC	1.000	C28	.	.	.	.
30000423	CAP EL 47UF 400V M	PC	1.000	C1	.	.	.	.
30001155	RES MO 2W 33K J	PC	1.000	R18	.	.	.	.
30001284	DIODE 1N4148 0.15A/100V 0.5A	PC	1.000	D7	.	.	.	.
.	.	PC	4.000	D1	D2	D3	D4	.
30001302	DIODE BYW29-200 8A/200V 80A	PC	1.000	D9	.	.	.	.
30001318	DIODE BA159 1A/800V 20A	PC	3.000	D8	D13	D16	.	.
30001329	DIODE 1N4007 1A/1000V 30A	PC	4.000	D1	D4	D5	D6	.
30001343	DIODE ZENER 5.6V	PC	1.000	D17	.	.	.	.
30001350	DIODE ZENER 12V	PC	1.000	D18	.	.	.	.
30001453	TR BC337	PC	1.000	Q3	.	.	.	.
30001454	TR BC548B	PC	1.000	Q2	.	.	.	.
30001503	IC CQY80NG (OPT COUPLER)	PC	1.000	IC2	.	.	.	.
30001506	IC TL431	PC	1.000	D14	.	.	.	.
30001731	FUSE 2.5A 250V 5*20MM	PC	1.000	F1	.	.	.	.
30010501	R/C DVD (BLACK)	PC	1.000	.	.	.	.	.
30010700	DIODE BYV28-200 3.5A/200V 90A	PC	1.000	.	.	.	.	.
30010798	IC TOP223Y	PC	1.000	IC3	.	.	.	.
30011787	POWER CORD ASSY (.2.4MT W/FTZ)-SATELLITE-	PC	1.000	.	.	.	.	.
30012923	DVD LOADER (ATAPI INTERFACE)	PC	1.000	.	.	.	.	.
30012968	CONN ASSY 4/20 POWER (5.00 mm)	PC	1.000	.	.	.	.	.
30014124	IC 74LVX245	PC	2.000	.	.	.	.	.
30015742	CONN ASSY 5P 15cm FLAT	PC	1.000	.	.	.	.	.
30016022	SWITCH TACT VERTICAL T&R	PC	15.000	SW1	SW10	SW11	SW12	SW13
.	.	.	.	SW14	SW15	SW16	SW2	SW3
.	.	.	.	SW5	SW6	SW7	SW8	SW9
30016833	IC LM317T-2	PC	1.000	IC6	.	.	.	.
.	.	PC	1.000	.	.	.	.	.
30016836	CONN ASSY 6P 23cm W/FERRITE	PC	1.000	.	.	.	.	.
30017144	CONN ASSY 8P 30CM W/FERRITE (TMM)	PC	1.000	.	.	.	.	.
30017992	CONN ASSY 40P 22CM (IDE CABLE)	PC	1.000	.	.	.	.	.
30018125	CONN ASSY 10P 12CM W/FERRITE CORE W/B	PC	1.000	.	.	.	.	.
40009968	PLASTIK AYAK DVD2200+DVB (SYAH)	PC	4.000	.	.	.	.	.
40009969	PLASTIK AYAK PYMY (SYAH)	PC	4.000	.	.	.	.	.

**NOTE: YOU CAN FIND SPARE PART CODES FOR MODEL- DEPENDENT PARTS IN OUR SERVICE WEB SITE : [www.vestelSERVICE.com](http://www.vestelSERVICE.com)**

COMPONE		6CH MP3							
NT CODE	MATERIAL	UNIT	QTY	POSITION NUMBER					
20071876	POWER BOARD CHS.DVD-3000 (MAN)(5508-DVS)	PC	1.000	.	.	.	.	.	.
20071877	MAINBOARD CHS.DVD-3000 (MAN) DVS-6CH	PC	1.000	.	.	.	.	.	.
20087598	FRONT P.2310 M.SLV+LOGO *UNIVERS.MP3 AC3	PC	1.000	.	.	.	.	.	.
20092998	SCART ASSY DVD-3000 (MAN) (FERRITE)	PC	1.000	.	.	.	.	.	.
20100794	FRONT PANEL DVD2300 (MAN) (SC FERRITE)	PC	1.000	.	.	.	.	.	.
30000158	CAP MKP 4.7NF 630V J	PC	1.000	C28	.	.	.	.	.
30000423	CAP EL 47UF 400V M	PC	1.000	C1	.	.	.	.	.
30001155	RES MO 2W 33K J	PC	1.000	R18	.	.	.	.	.
30001284	DIODE 1N4148 0.15A/100V 0.5A	PC	1.000	D7	.	.	.	.	.
.	.	PC	4.000	D1	D2	D3	D4	.	.
30001302	DIODE BYW29-200 8A/200V 80A	PC	1.000	D9	.	.	.	.	.
30001318	DIODE BA159 1A/800V 20A	PC	3.000	D8	D13	D16	.	.	.
30001329	DIODE 1N4007 1A/1000V 30A	PC	4.000	D1	D4	D5	D6	.	.
30001343	DIODE ZENER 5.6V	PC	1.000	D17	.	.	.	.	.
30001350	DIODE ZENER 12V	PC	1.000	D18	.	.	.	.	.
30001453	TR BC337	PC	1.000	Q3	.	.	.	.	.
30001454	TR BC548B	PC	1.000	Q2	.	.	.	.	.
30001503	IC CQY80NG (OPT.COUPLER)	PC	1.000	IC2	.	.	.	.	.
30001506	IC TL431	PC	1.000	D14	.	.	.	.	.
30001731	FUSE 2.5A 250V 5*20MM	PC	1.000	F1	.	.	.	.	.
30010501	R/C DVD (BLACK)	PC	1.000	.	.	.	.	.	.
30010700	DIODE BYV28-200 3.5A/200V 90A	PC	1.000	.	.	.	.	.	.
30010798	IC TOP223Y	PC	1.000	IC3	.	.	.	.	.
30011787	POWER CORP ASSY.(2.4MT W/FTZ)-SATELLITE-	PC	1.000	.	.	.	.	.	.
30012923	DVD LOADER (ATAPI INTERFACE)	PC	1.000	.	.	.	.	.	.
30012968	CONN ASSY 4/20 POWER (5.00 mm)	PC	1.000	.	.	.	.	.	.
30014124	IC 74LVX245	PC	2.000	.	.	.	.	.	.
30015742	CONN ASSY 5P 15cm FLAT	PC	1.000	.	.	.	.	.	.
30016022	SWITCH TACT VERTICAL T&R	PC	7.000	SW1	SW2	SW3	SW5	SW6	.
.	.	.	.	SW7	SW8	.	.	.	.
30016833	IC LM317T-2	PC	1.000	.	.	.	.	.	.
.	.	PC	1.000	IC6	.	.	.	.	.
30016836	CONN ASSY 6P 23cm W/FERRITE	PC	1.000	.	.	.	.	.	.
30017144	CONN ASSY 8P 30CM W/FERRITE (TMM)	PC	1.000	.	.	.	.	.	.
30017992	CONN ASSY 40P 22CM (IDE CABLE)	PC	1.000	.	.	.	.	.	.
30018125	CONN ASSY 10P 12CM W/FERRITE CORE W/B	PC	1.000	.	.	.	.	.	.
40009501	RUBBER FOOT ADHESIVE (PINGOOD C190603)	PC	4.000	.	.	.	.	.	.
50025094	I/B DVD2310*UNIVERSUM DVD8121/GER (ORT.)	PC	1.000	.	.	.	.	.	.

NOTE: YOU CAN FIND SPARE PART CODES FOR MODEL-DEPENDENT PARTS IN OUR SERVICE WEB SITE : [www.veselSERVICE.com](http://www.veselSERVICE.com)

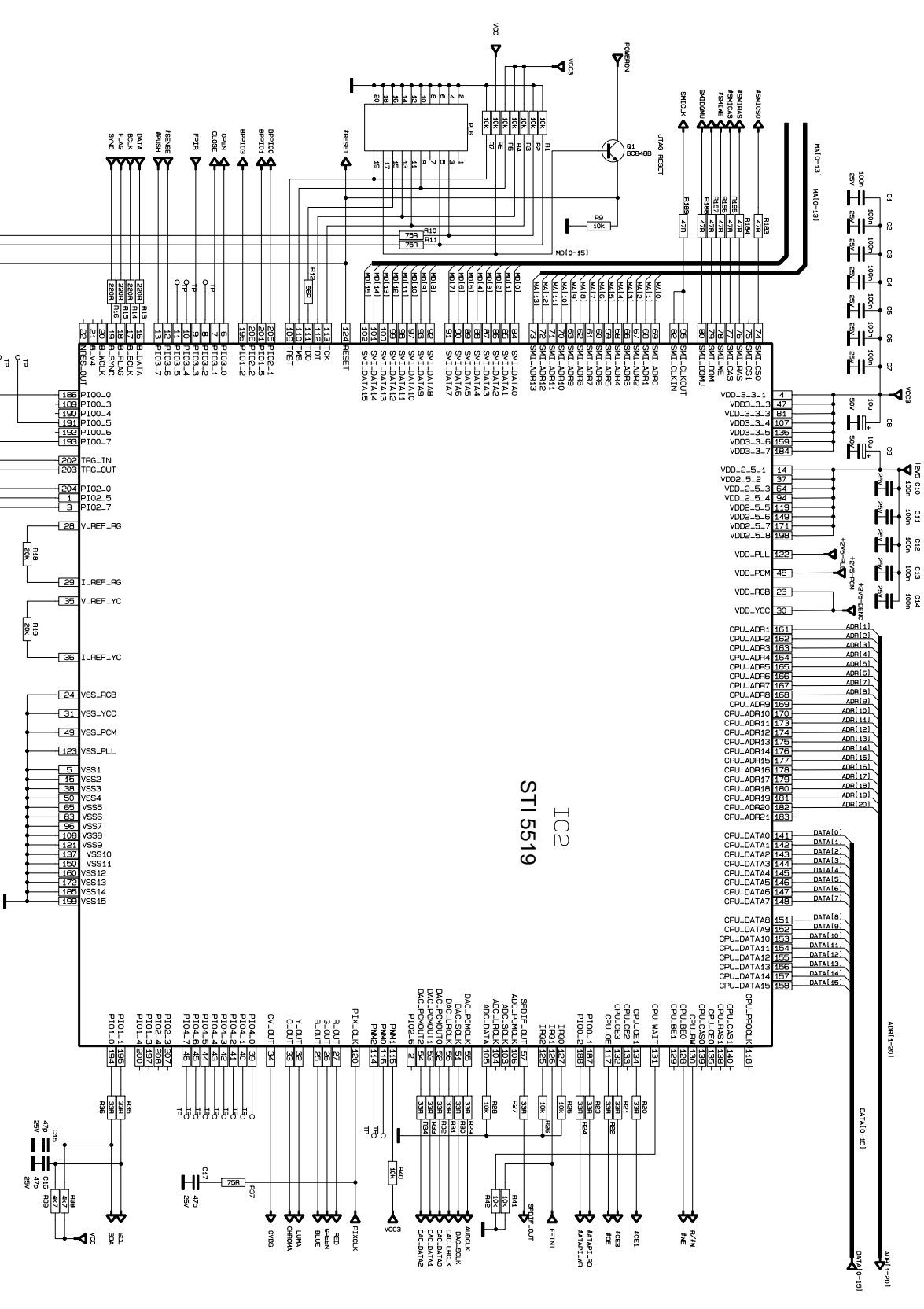

IC2  
STI 5519

VESTEL ELECTRONICS			
Digital			
Chip Name	STI 5519		
Vic#	Rev.	Date	Author
1	1	15-02-2000	Wesley van der Vliet
Sheet	1 of 12		

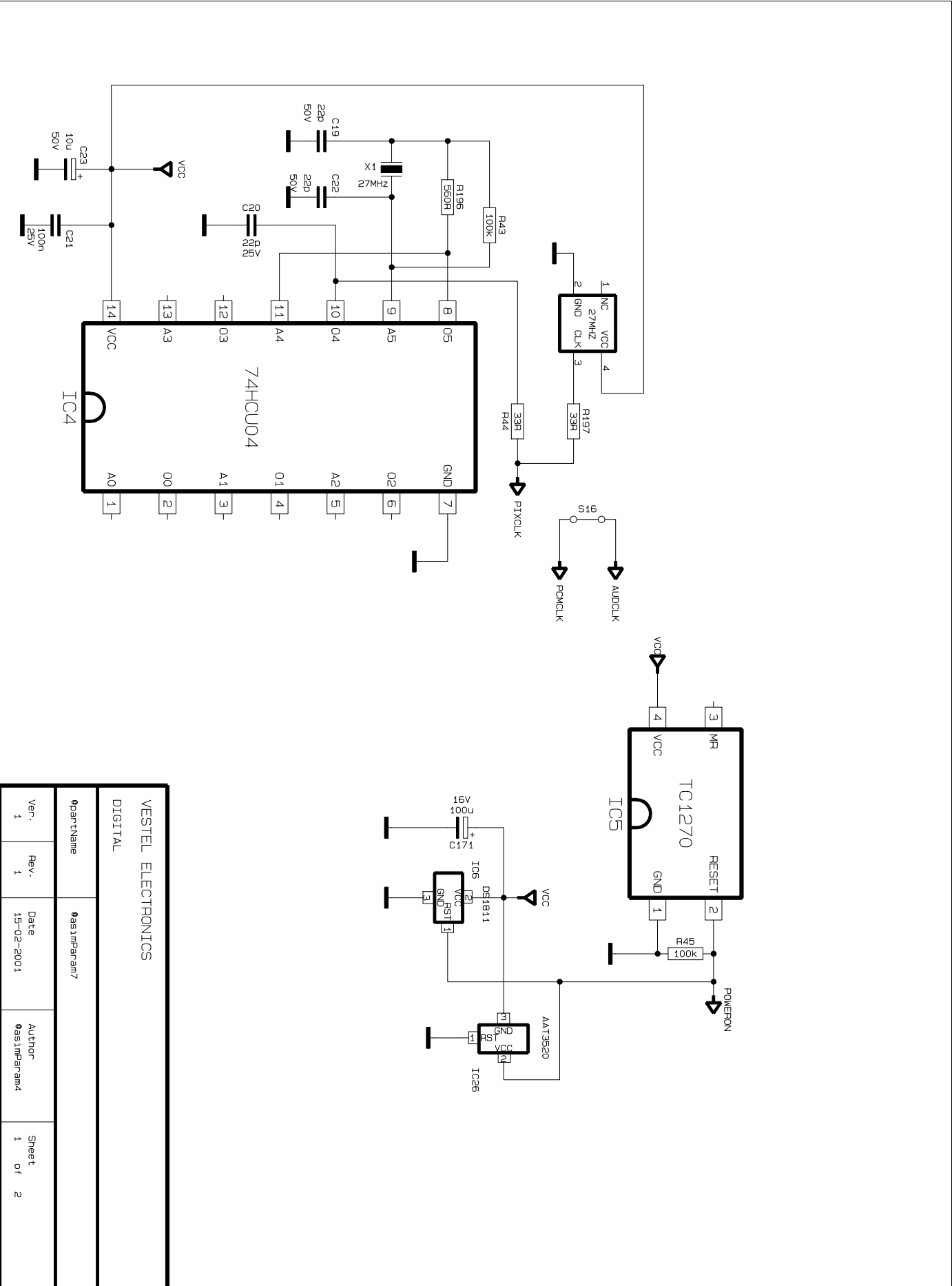

VESTEL ELECTRONICS  
DIGITAL

PartName		QasimParan7		Author		QasimParan4		Sheet	
Ver.		1		Date		15-02-2001		1	
Rev.		1		Date		15-02-2001		of	
								2	

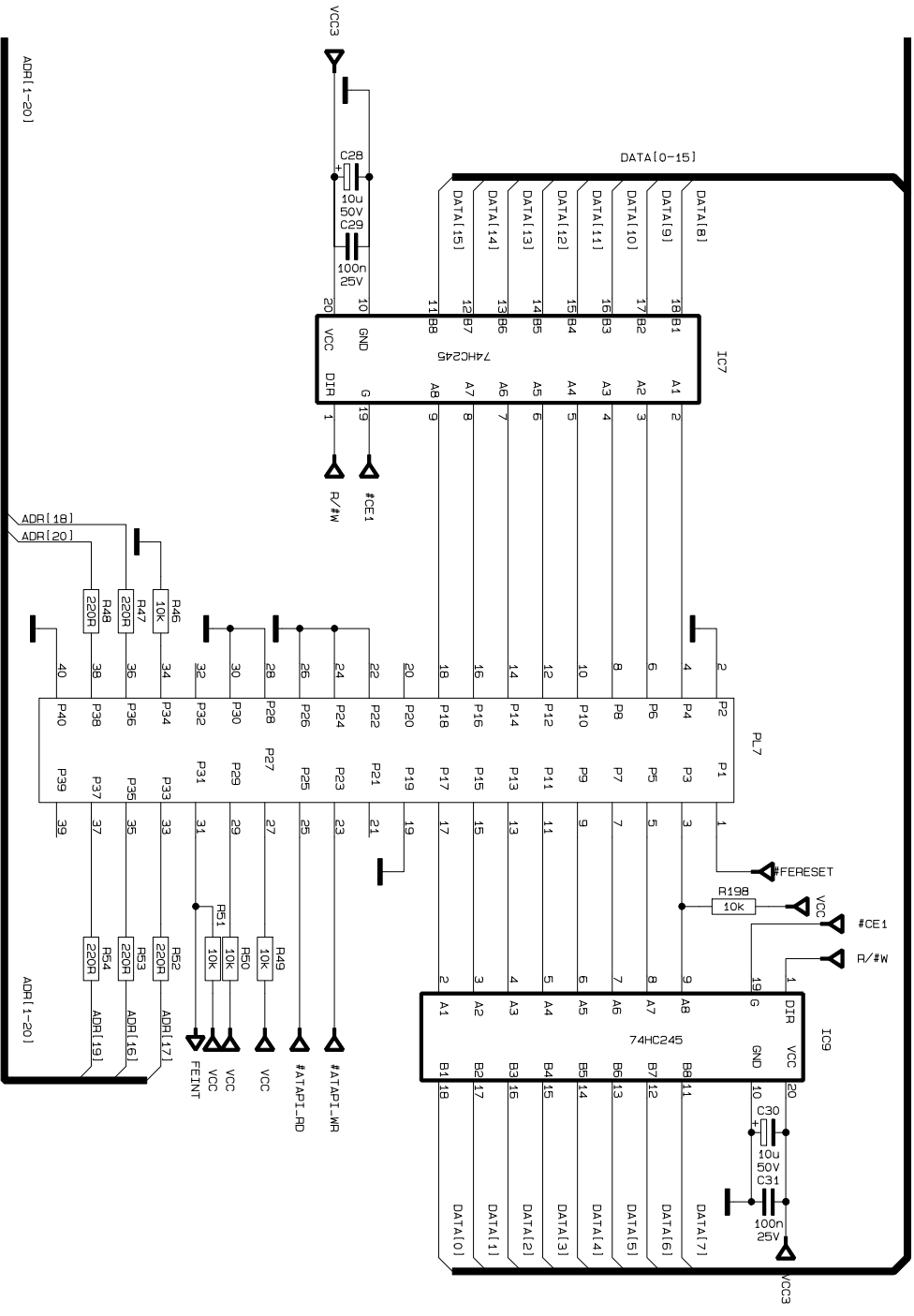

APR(1-20)

APR(1-20)

VESTEL ELECTRONICS  
DIGITAL

PartName		ATAPI INTERFACE	
Ver.	Rev.	Date	Author
1	1	20-02-2001	QasimParam4
			Sheet
			1 of 3

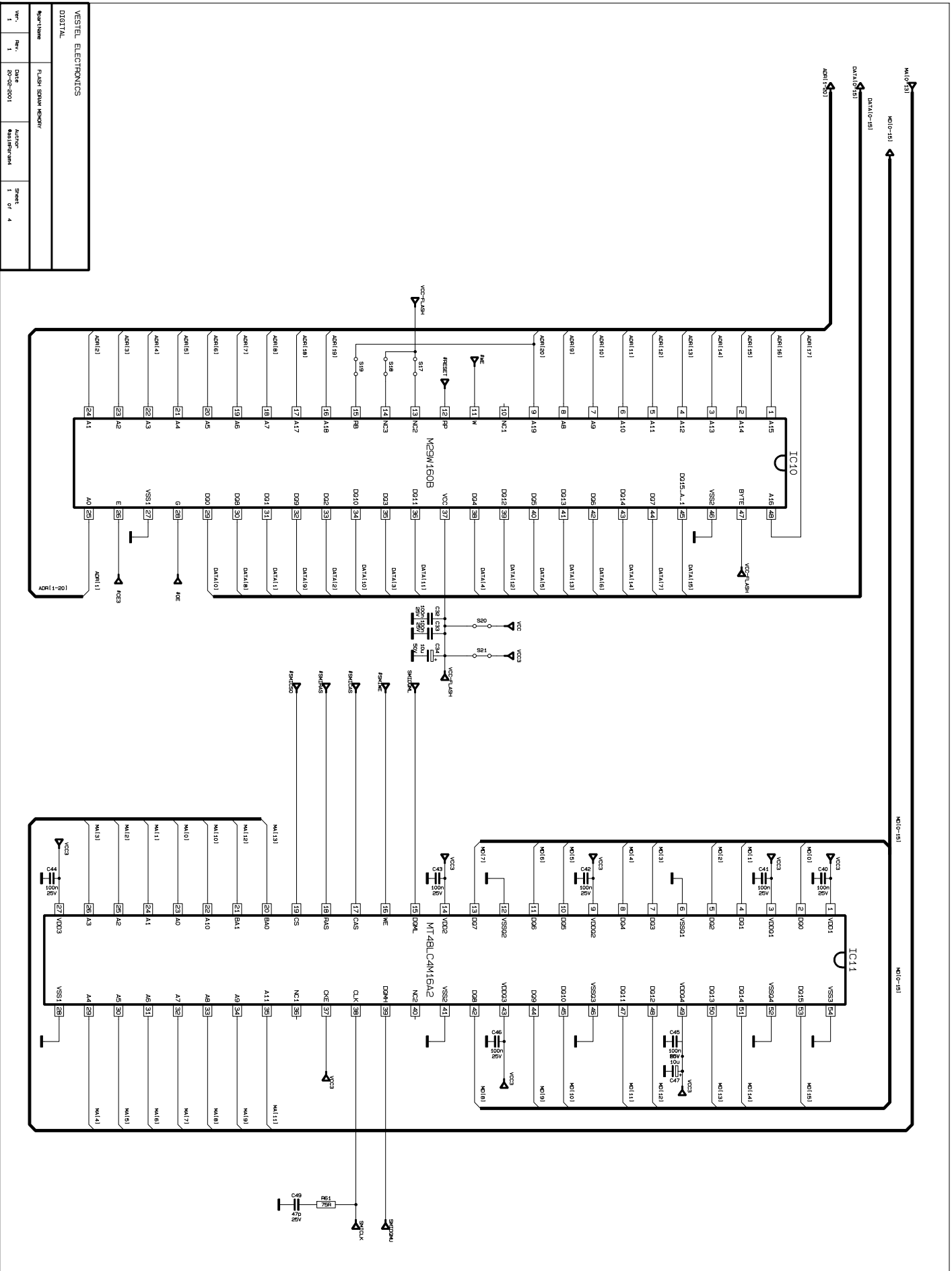

VESTEL ELECTRONICS			
DIGITAL			
Type: FLASH MEMORY			
Rev: 1	Date: 20-02-2001	Number: 1	Sheet: 4

6

5

4

3

2

1

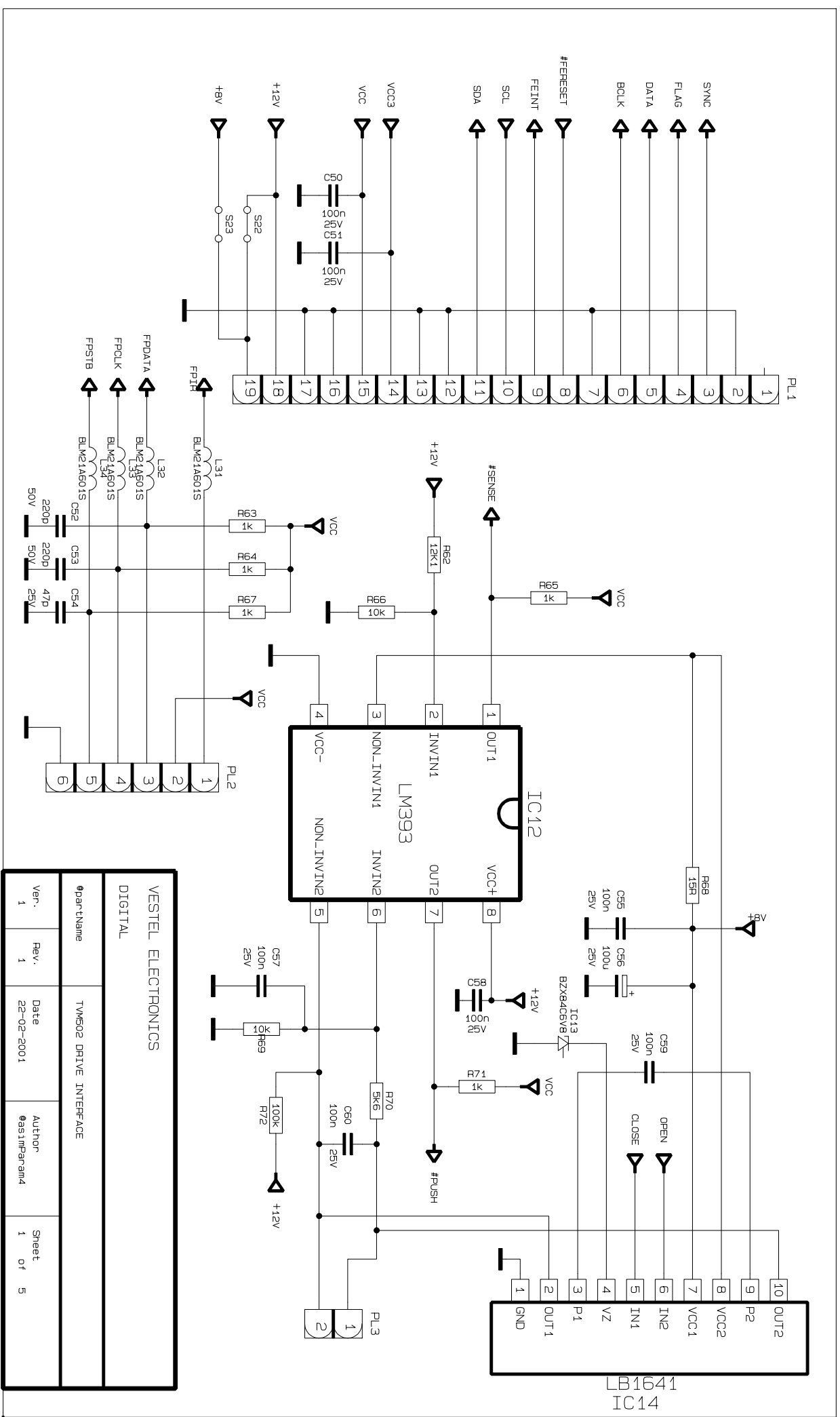

VESTEL ELECTRONICS		TVM502 DRIVE INTERFACE		Sheet of 5	
DIGITAL		Author @ssimparam4		1 of 5	
partName		Date 22-02-2001		Sheet of 5	
Ver. 1	Rev. 1	Author @ssimparam4		1 of 5	



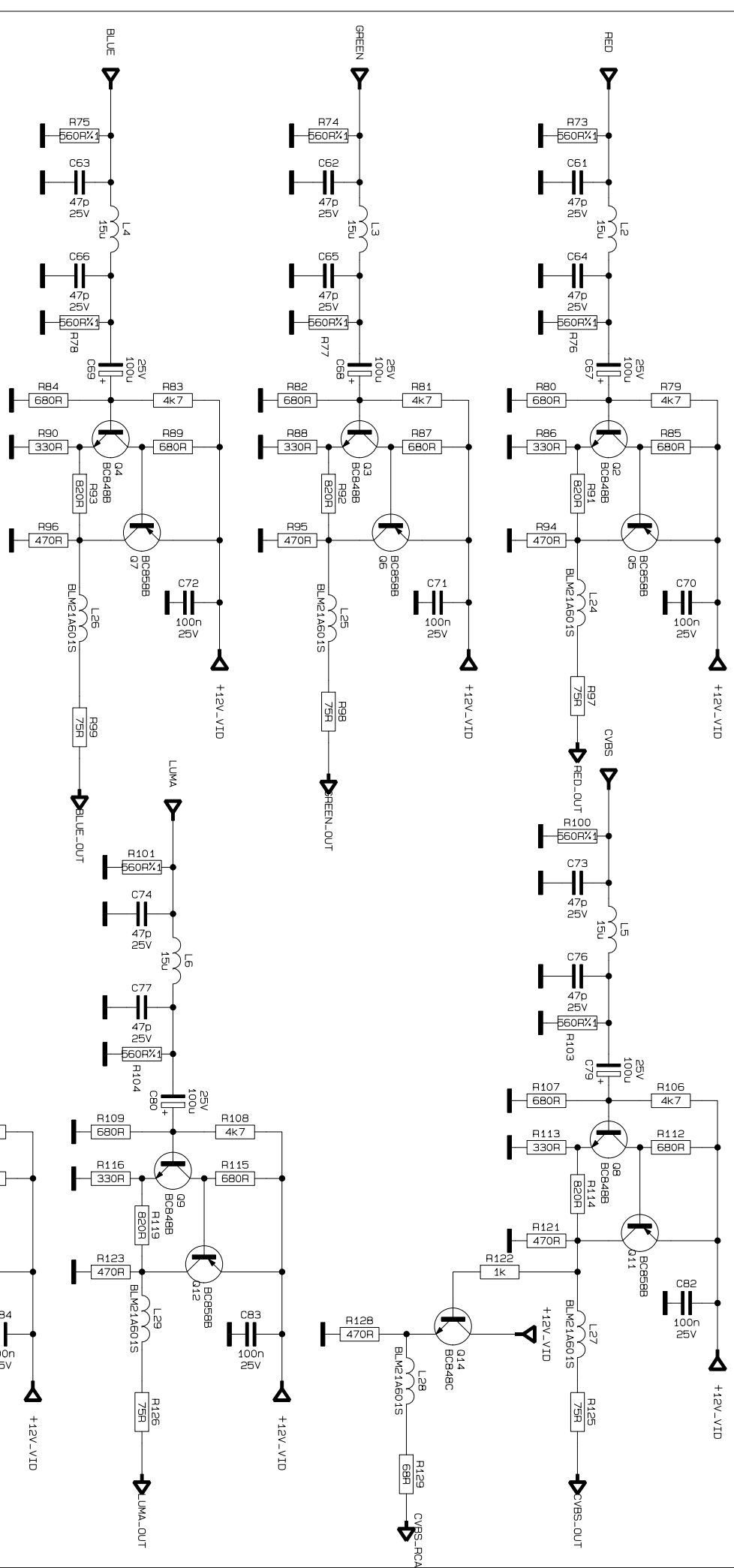

**VESTEL ELECTRONICS**

**DIGITAL**

PartName		@asImpParam7	
Ver.	Rev.	Date	Author
1	1	23-02-2001	@asImpParam4
		Sheet	of
		1	6

CHROMA

LUMA

BLUE\_OUT

CVBS\_OUT

CHROMA\_OUT

CVBS\_OUT

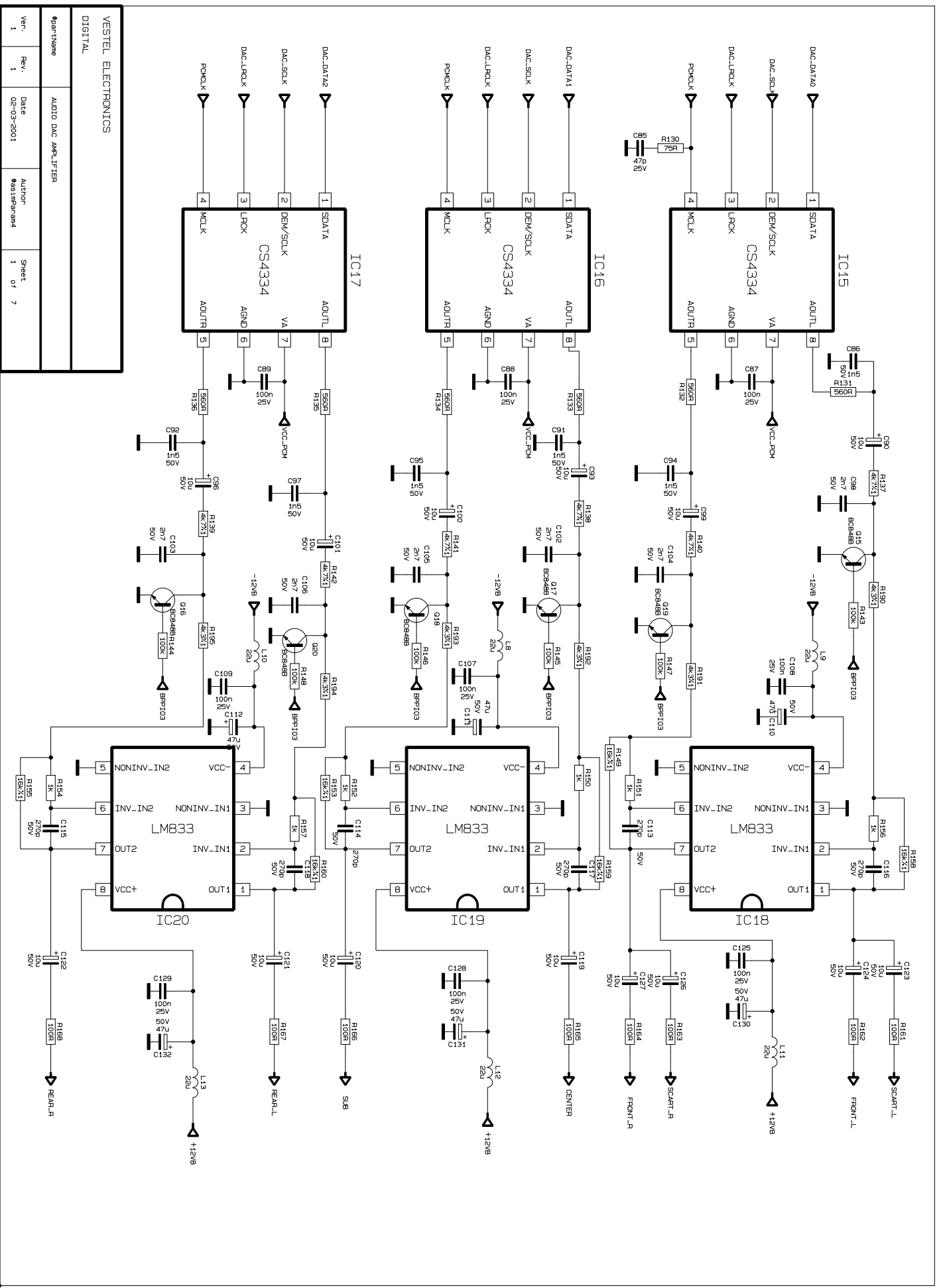

VESTEL ELECTRONICS  
DIGITAL

PartName	AUDIO DAC AMPLIFIER		
Ver.	1	Date	02-03-2001
Rev.	1	Author	@astimperand
Sheet	1	of	7

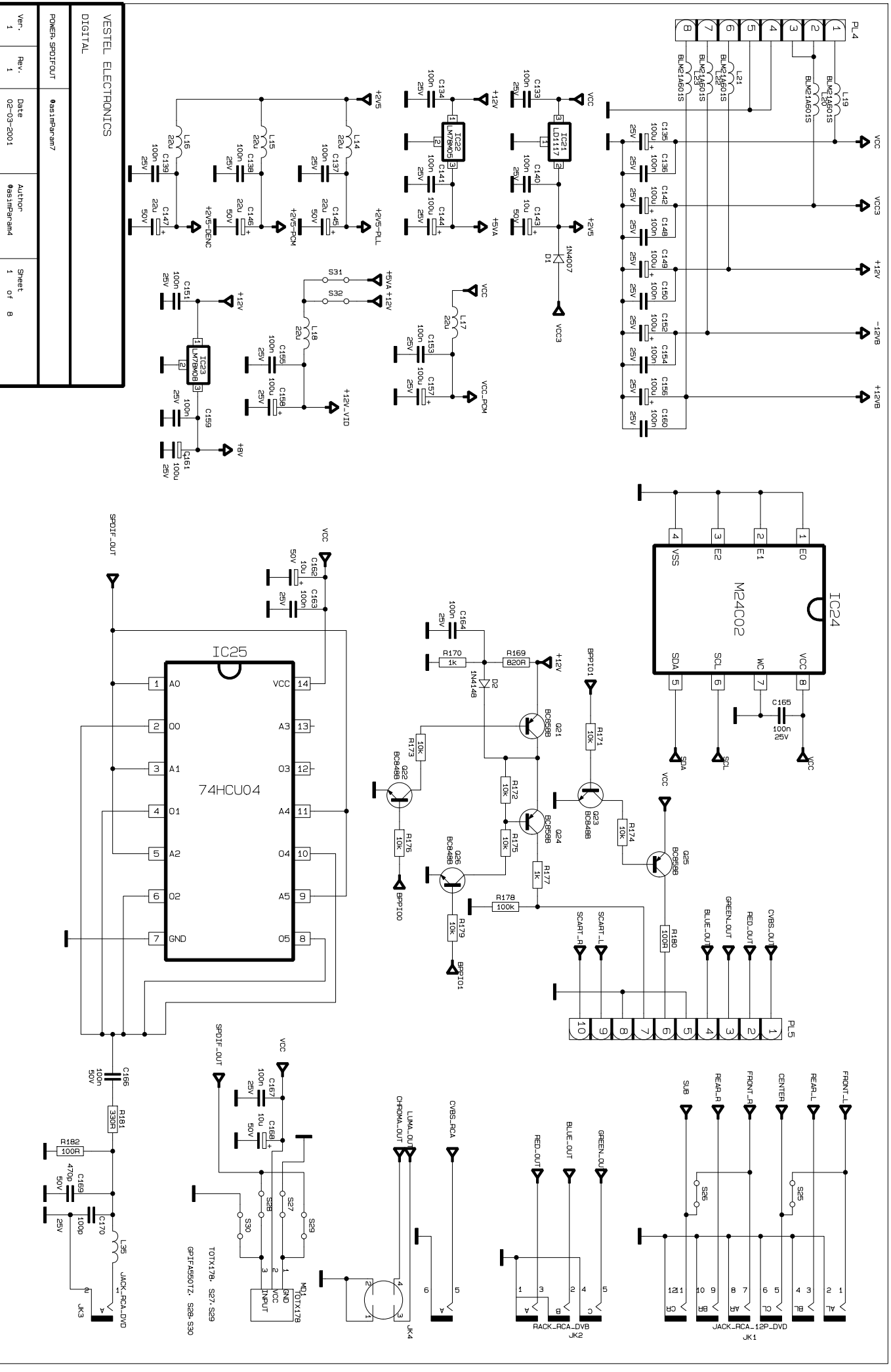

VESTEL ELECTRONICS	
DIGITAL	
POWER SP0IFOUT	09a1mpParan7
Ver. 1	Rev. 1
Date 02-03-2001	Author 09a1mpParan4
Sheet 1 of 8	

4

3

2

1

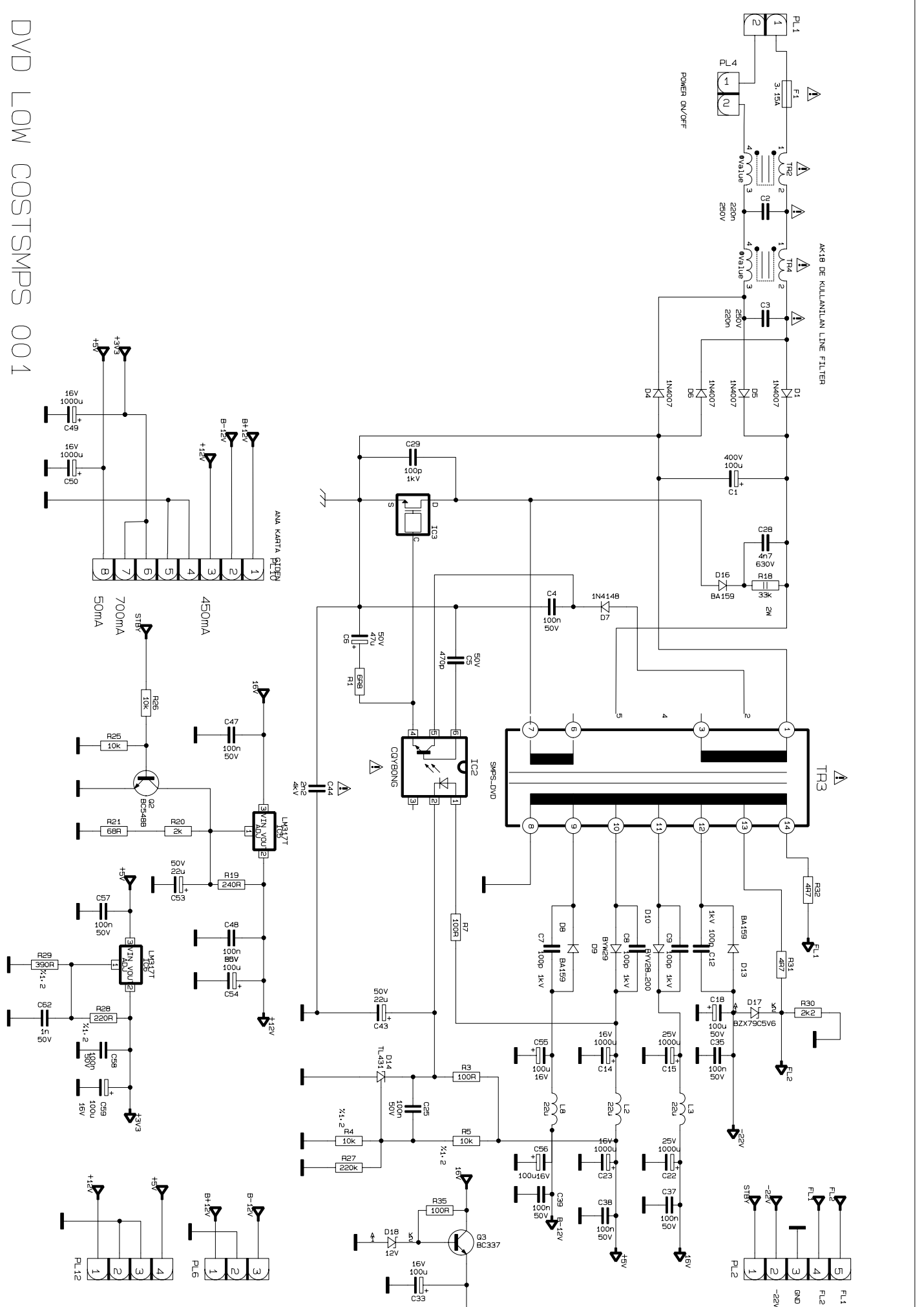

DVD LOW COSTSMP5 001

1  
2  
3  
4  
5  
6  
7  
8  
9  
10  
11  
12  
13  
14  
15  
16  
17  
18  
19  
20  
21  
22  
23  
24  
25  
26  
27  
28  
29  
30  
31  
32  
33  
34  
35  
36  
37  
38  
39  
40  
41  
42  
43  
44  
45  
46  
47  
48  
49  
50  
51  
52  
53  
54  
55  
56  
57  
58  
59  
60  
61  
62  
63  
64  
65  
66  
67  
68  
69  
70  
71  
72  
73  
74  
75  
76  
77  
78  
79  
80  
81  
82  
83  
84  
85  
86  
87  
88  
89  
90  
91  
92  
93  
94  
95  
96  
97  
98  
99  
100

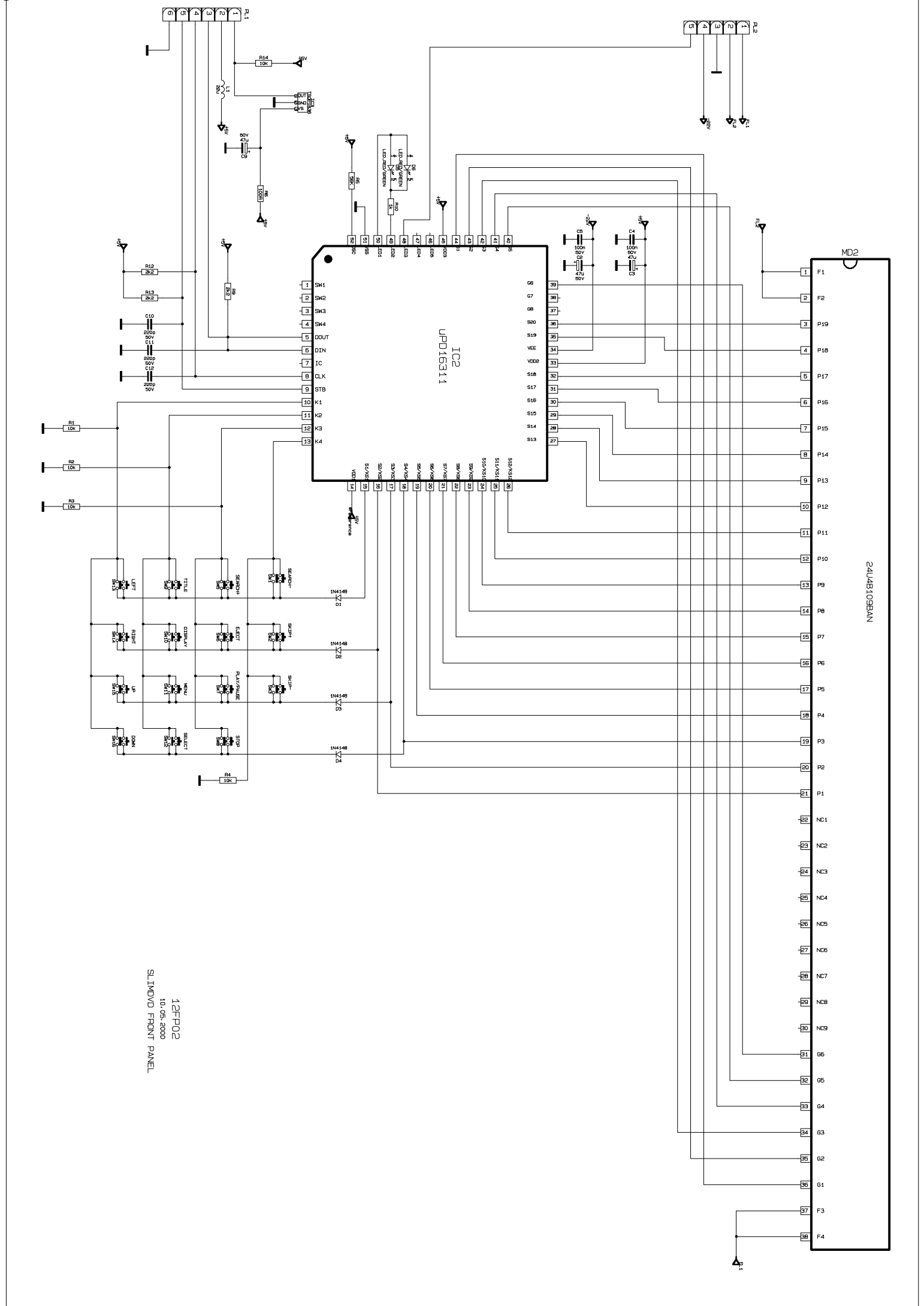

12FP02  
10.05.2000  
SLIMDVD FRONT PANEL