

---

# ARC INVERTER



INSTRUCTION MANUAL

---

# Contents

Warning .....	3
General Description .....	4
Block Diagram .....	4
Main Parameters .....	5
Circuit Diagram .....	5
Installation and Operation .....	6
Caution .....	7
Maintenance .....	7
Spare Parts List .....	8
Troubleshooting .....	10

## EC DECLARATION OF CONFORMITY

We hereby declare that the following machines:

ARC120 / ARC140 Dual Voltage / ARC160 / ARC200B

correspond to the following edicts and standards:

EMC Directives: 73/23/EEC and 89/336/EEC

European Standard: EN/IEC60974

# Warning

Welding and cutting is dangerous to the operator, people in or near the working area, and the surrounding environment. Therefore, the performance of welding and cutting must only be done under the strict and comprehensive observation of all relevant safety regulations. Please read and understand this instruction manual carefully before installation and operation.

- Switching function modes during welding could potentially damage the equipment.
- Disconnect the electrode-holder cable from the equipment before welding.
- A safety switch is necessary to prevent the equipment from electric-leakage.
- Use only high quality welding tools and equipment with this Inverter.
- Operators should be suitably trained to use this equipment.

## Electric Shock

- Connect the earth cable according to standard regulation.
- Avoid any contact with live components of the welding circuit, electrodes and wires with bare hands. The operator should wear suitable welding gloves while using this machine.
- The operator should keep the work piece insulated from himself/herself.



## Smoke and Gas generated while welding or cutting

- Avoid breathing in smoke and gas from welding or cutting.
- Make sure the area you are working in is a well ventilated area.

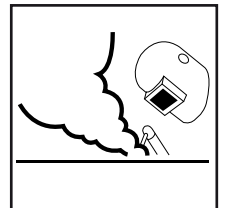

## Arc light-emission

- Always wear a welding helmet and appropriate work clothes while welding.
- Measures should also be taken to protect people in or near the area you are working.

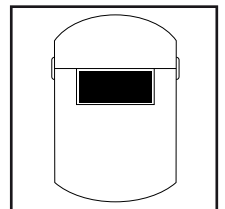

## Fire hazard

- Sparks from welding may cause fire. Remove any flammable items from the immediate area before welding.
- Have a fire extinguisher nearby.

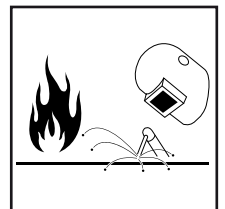

## Noise

- Surface noise is generated while welding and cutting. Use suitable hearing protection.

## Machine Fault

- Consult this instruction manual in the case of a fault.
- Contact your local dealer or supplier for further advice.

# General Description

This welding machine is manufactured with advanced inverter technology. With power component MOSFET and PWM technology, the inverter converts DC voltage, which is rectified from input AC voltage, to high 100KHz frequency AC voltage; as a consequence, the voltage is transformed and rectified. Therefore, it results in a smaller transformer and lighter inverter machine, which increases welding performance by 30%. The high frequency oscillation, which enables the output of high frequency DC, is employed in the arc-starting system. The features of this product are as follows: stable current, reliable, fully portable, efficient and quiet in operation.

Warranty of maintenance for main components is one year. During the warranty period, all maintenance is free of charge, not including any deliberate damage or alteration to this welding equipment.

In the case of a fault with the inverter machine, only qualified electricians are authorized to carry out repairs.

# Block Diagram

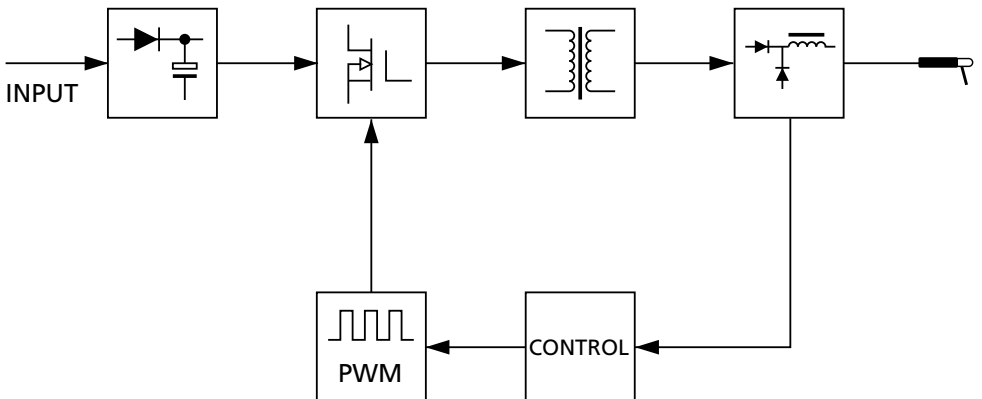

# Main Parameters

	ARC120	ARC140 DV	ARC160	ARC200B
Fuse Rating	13 amp	110 volt 15 amps 240 volt 13 amps	16 amps	20 amps
Generator Friendly	+ / - 15%	+ / - 15%	+ / - 10%	+ / - 10%
Input Power Voltage	AC 230 volt (single phase)	110 / 230 volt (single Phase)	AC 230 volt (single phase)	AC 230 volt (single phase)
Rate Input Power Capacity	3.8 KVA	4.4 KVA	5.3 KVA	7 KVA
Input Voltage Frequency	50 / 60 Hz	50 / 60 Hz	50 / 60 Hz	50 / 60 Hz
Output Current Range	10 – 120 amps	10 – 140 amps	20 – 160 amps	20 – 200 amps
Duty Cycle (25°C)	120 amps @ 60%	110 volt 100 amps @ 100% 240 volt 140 amps @ 60%	155 amps @ 60%	200 amps @ 60%
Weight	5 kg	6.4 kg	8 kg	10 kg
Overall Dimensions	230 x 120 x 170 mm	290 x 132 x 216 mm	371 x 155 x 295 mm	425 x 205 x 355 mm
Protection Class	Ip23	Ip23	Ip23	Ip23
Diameter of Rod	1.6 mm – 3.2 mm	1.6 mm – 3.2 mm	1.6 mm – 4.0 mm	1.6 mm – 5.0 mm

## Circuit Diagram (single phase input)

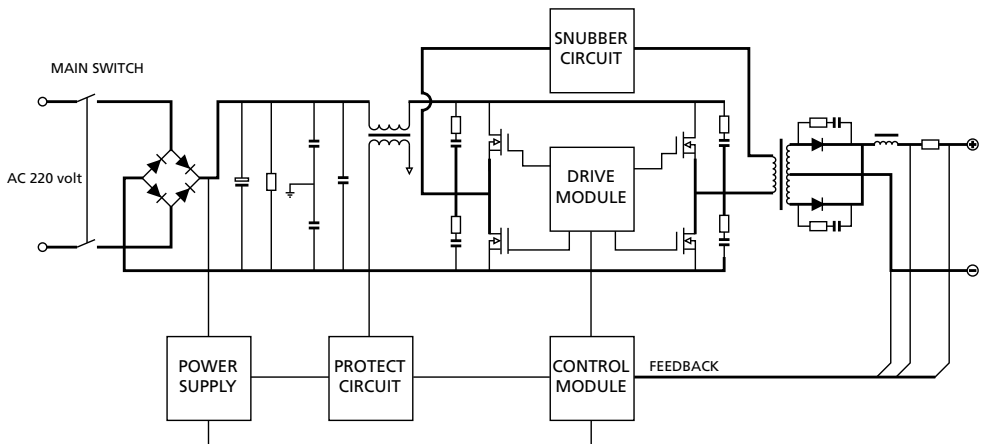

# Installation and Operation

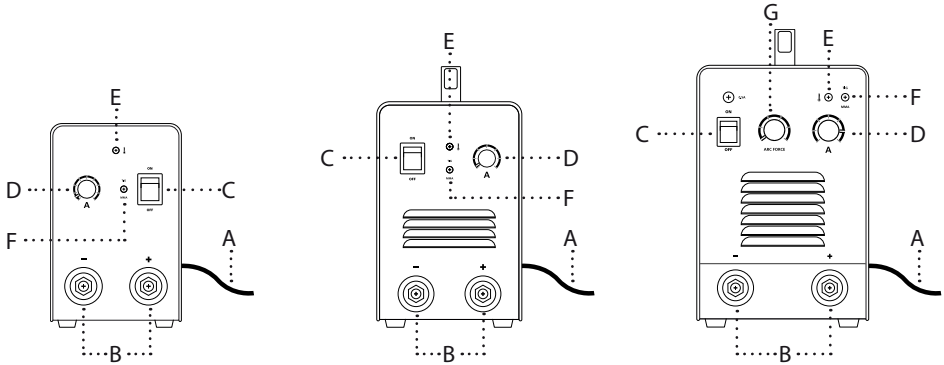

## A : Mains Lead

A primary power supply cable is available for this welding equipment. Connect the power supply cable with required voltage. Check whether the voltage value varies in the given range with a multi-meter.

## B : Connection of Output Cables

Two Dinze sockets are available for this welding equipment. Connect the plug to the socket on the panel board. It is possibly damaging to both the plug and socket, if the plug and the socket are incorrectly connected.

The electrode holder cable should be connected to the negative terminal, while the work piece should be connected to the positive terminal.

•Positive connection electrode holder to “-”,while work piece to “+”

•Negative connection work piece to “-”, while electrode holder to “+”.

It is necessary to increase the diameter of cable in order to maintain and improve the performance of voltage output.

## C : On / Off Switch

While the power supply switch is on, the built-in fan works and current meter displays the current value.

## D : Welding Current Output Setting

According to practical demand, set the parameters of current output by the operation of welding current knob and arc-leading pulse knob.

## E : O.C. Light

When the pilot lamp is lit, the machine is in a temporary shut down mode to prevent damage from over heating. The machine will automatically restart when the internal temperature has dropped to a safe operational level.

## F : TIG / MMA Switch

Select between TIG and MMA welding process.

G : Arc Force Knob (Arc200B only)

Arc Force knob is available for the improvement of arc-starting, especially in case of low current input.

## Caution

### 1. Working Environment

1.1 The location in which this welding equipment is installed should be free from dust, corrosive chemical gas, flammable gas or materials.

1.2 Avoid the operation of welding in the open air unless the working area sheltered from the elements. The ambient temperature of the working environment should be maintained within  $-10^{\circ}\text{C}$  to  $+40^{\circ}\text{C}$ .

1.3 Allow a distance of at least 300mm (12") between this machine and any walls.

1.4 Make sure the area you are working in is well ventilated.

### 2. Safety Tips

2.1 Ventilation: Good ventilation is of critical importance for the performance and service life of this inverter welding machine. Maintain a minimum distance of 30cm (12") between the inverter machine and any other objects in or near the working area.

2.2 Do not operate this machine when the O.C. Light is lit.

A sudden halt may occur while the welding operation is carried out while this welding machine is of over-load status. Under this circumstance, it is unnecessary to restart this welding equipment. Keep the built-in fan working to bring down the temperature inside this welding equipment.

2.3 This welding equipment uses automatic voltage compensation, which enables the maintaining of the voltage range within the given range. In case the voltage of input power supply current exceeds the stipulated value, it is possibly damaging to the components of this welding equipment.

2.4 An earth terminal is available for this welding equipment. Connect with the earth cable to avoid static and electric shock.

2.5 DO NOT contact the output terminal when the welding operation is performed. An electric shock will occur.

## Maintenance

Exposure to extremely dusty, damp, or corrosive air is damaging to this machine. In order to prevent any possible failure or fault of the inverter, clean any dust at regular intervals with compressed air.

Please note: Proper maintenance should be carried out by a skilled and qualified technician on a regular basis. Any attempts by an unauthorised or unskilled individual to remove the outer casing, or conduct repairs or modifications to the machine will void the warranty.

# Spare Parts List

Description		Part Number			
		ARC120	ARC140 DV	ARC160	ARC200B
A	Front Panel				
B	Cover				
C	Carrying Strap / Handle				
D	Dial				
E	Dinze Socket				
F	On / Off Switch				
G	Power Cable				
H	Internal Fan				
I	Bottom PCB				
J	Heat Sink				
K	Center PCB				
L	Rubber Feet				
M	Top PCB				

## ARC120

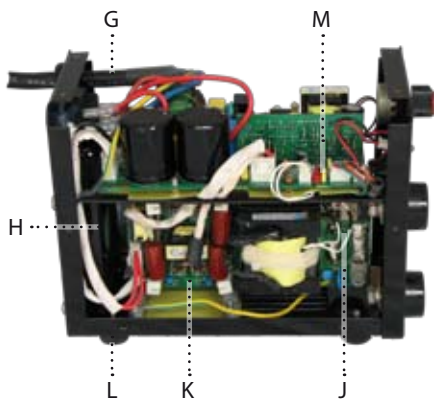
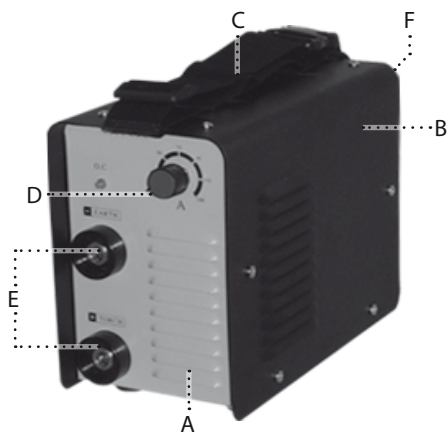



### ARC140



### ARC160



### ARC200B

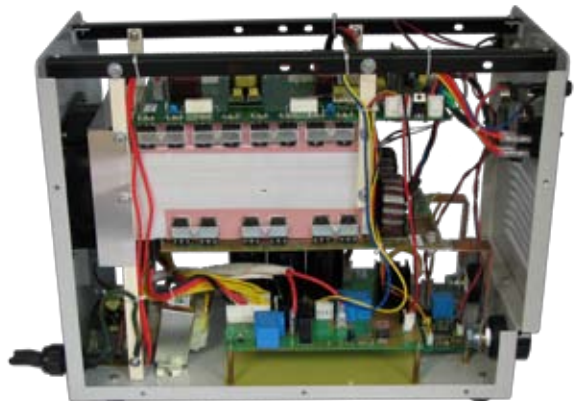

# Troubleshooting

Please note: In the event of a fault with this inverter welding machine, only qualified technicians are authorised to undertake repairs.

Fault Symptoms	Reason
No output from machine, O.C. Light not lit, internal fan not working	<ol style="list-style-type: none"> <li>1. Possible failure of voltage input. Consult an authorised technician.</li> <li>2. Possible failure of power supply. Check plug and power cable for damage.</li> </ol>
No output from machine, O.C. Light not lit, internal fan not working, machine suddenly halts operation	<ol style="list-style-type: none"> <li>1. Possible failure of power supply. Check plug and power cable for damage.</li> <li>2. The machine is in temporary shut down mode due to over heating. Wait a few minutes for machine to cool down and it will automatically re-start.</li> <li>3. Power supply input is faulty. Check plug and power cable for damage.</li> <li>4. The machine is in temporary shut down mode due to constantly being switched on and off. Unplug the machine and wait 5 minutes before re-starting.</li> <li>5. 24 volt relay board may be defective. Consult an authorised technician for a replacement.</li> <li>6. The top PCB is not receiving power. Consult an authorised technician.</li> </ol>
No output from machine, O.C. Light not lit, internal fan is working	<ol style="list-style-type: none"> <li>1. Possible loose connection in machine. Consult an authorised technician.</li> <li>2. Possible failure of Control Module / Drive Circuit / Drive Module. Consult an authorised technician for a replacement if necessary.</li> <li>3. Possible failure of MOSFET / Transformers / Rectifier Diode / Internal connections. Consult an authorised technician for a replacement if necessary.</li> </ol>
No output from machine, O.C. Light is lit	<ol style="list-style-type: none"> <li>1. The machine is in temporary shut down mode due to over heating. Wait a few minutes for machine to cool down and it will automatically re-start.</li> <li>2. The machine is in temporary shut down mode due to excess current.</li> <li>3. Possible function failure of inverter machine. Unplug the machine and perform the following checks:               <ol style="list-style-type: none"> <li>a) If the fault indicator is on MOSFET the top PCB is possibly faulty.</li> <li>b) If the fault indicator is off there could be damage to center PCB / possible damage to secondary rectifier of transformer.</li> <li>c) Possible damage to feedback circuit.</li> </ol>               Consult an authorised technician.             </li> </ol>



