

Let's get the party started (again)

µC-controlled LED earring

Christmas is over... and somehow we're still regaining strength after New Year's Eve. However, at Elektor this has nothing to do with resting, and even less with stop partying. Please take these earrings as a reminder ;)

By **Philip Jaschewski**
& **Thijs Beckers**
(Elektor Labs/Editorial)

Features

- Microcontroller driven earring with customizable light patterns
- Lightweight PCB design with 8 symmetrically arranged LEDs
- Very low power consumption (12 mW with multiplexed LEDs)
- Useful circuit for our own custom designs

The idea for this microcontroller driven LED earring arose when aspiring trainee Philip Jaschewski visited Elektor Castle together with his girlfriend on an exploratory visit. Being introduced to his new colleagues it was mentioned that she likes to handicraft earrings. For years, we've been designing electronic versions for different devices, so wouldn't it be very Elektor-like to do the same with earrings!? Few weeks later when Philip started his traineeship, one of his assignments was to elaborate on the idea of an electronic earring. Thus, we can keep the party going and Philip's girlfriend happy.

Ready for fun

A picture (or video) speaks a thousand words, so we say: watch this online video [1].

To cut a long story short, the switch S1 turns the device on, while with the push button you may choose between different modes of LED blinking (maybe depending on your mood, or the music!). The earring comes preprogrammed by default with four LED blinking patterns, but of course it's possible to reprogram the MSP430 microcontroller with your own patterns. The software will be described in detail later. Now for the 'nerdy part'...

Hardware: a stylish outfit

Figure 1 shows the electrical circuit diagram of the microprocessor controlled LED

earring. Starting at the left, the button cell provides 3 V to the circuit, after S1 is closed. The implementation of low-drop regulator IC2 is copied from it's datasheet. This low-drop regulator has a minimum voltage drop of 0.1 V from input to output. A fresh CR20xx cell has a voltage of 3.6 V. At the end of its life this has dropped to about 2.9 V, hence the choice for the LD6806TD/28H, which has an output voltage of 2.8 V.

The implementation of the MSP430G2152 microcontroller is also quite standard. X1 is providing a 4 MHz clock signal, (C3 and C4 are completing the Pierce oscillator circuit [2]). R9/R10/C5/S2 allow for manually altering between a high and a low level input signal, which is connected to port P2.0 of the MSP430. When S2 is closed, P2.0 is shorted to GND providing a low level signal. When S2 is open, C5 is charged to V_{CC} appearing a high level signal on P2.0. C5 buffers the signal and acts as a debouncing filter at the input. This level transitioning is used by the firmware to detect requests for program changes.

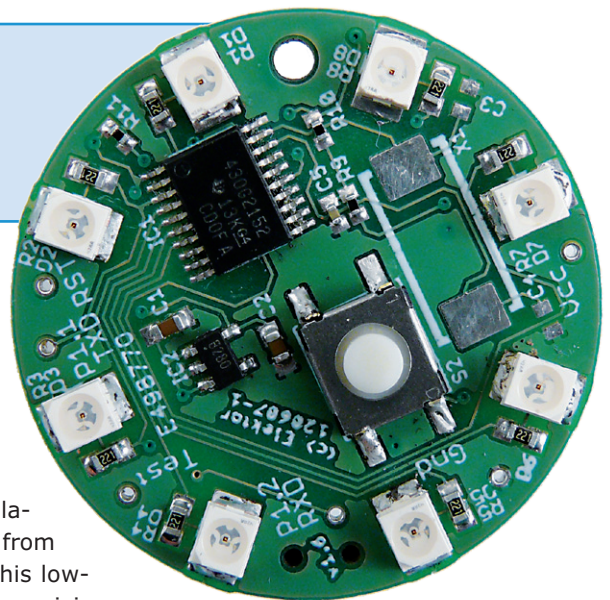

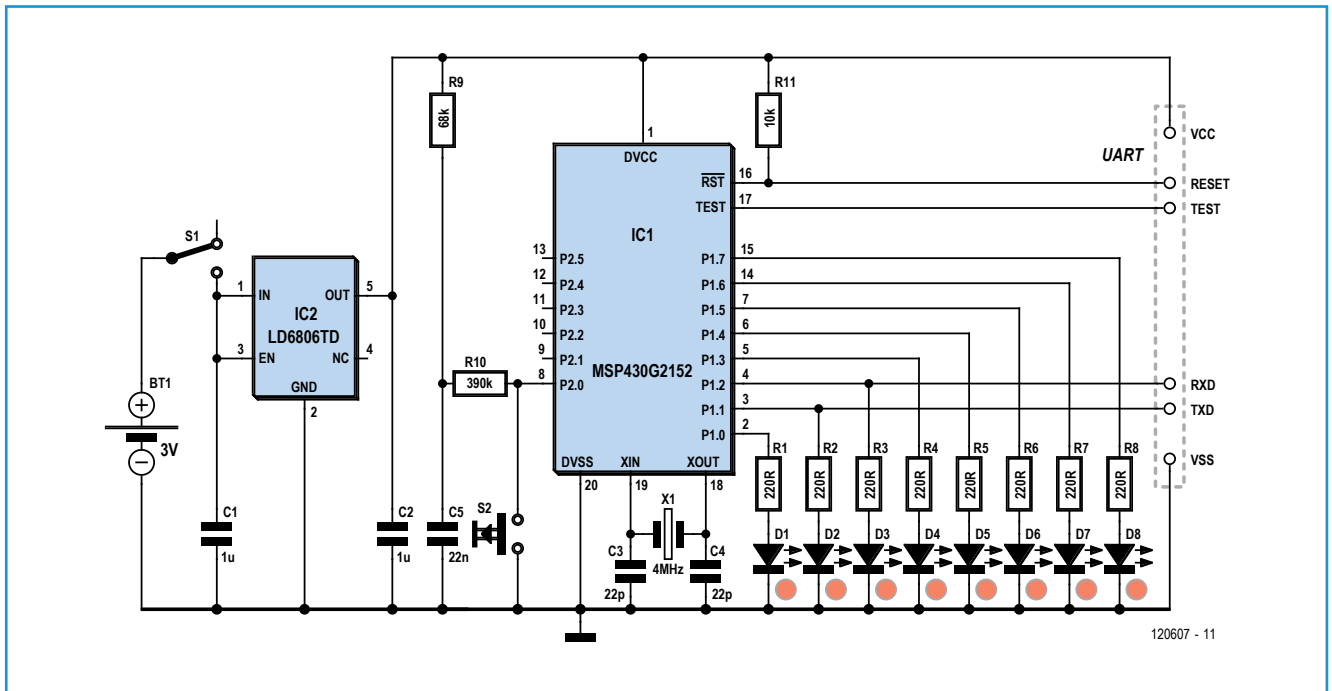

The eight LEDs are directly controlled and powered by the MSP430. To save power, when multiple LEDs are lit up, they are multiplexed — powered one at a time, very quickly alternating between each others, so to the eye it looks like they light up together. The average current through the LEDs is limited by means of the 100 Ω series resistors to 1.8 mA.

Software: party attitude

The firmware is available from the Elektor LABS site of this project [2]. Implemented are patterns of one, two or four running LEDs (in circular movement), as well as a fixed pattern with all LEDs on together. (Re)programming the microcontroller is effortless via the UART connection. The very affordable MSP430 LaunchPad Value Line Development kit [3] is ideally suited for this purpose. In order to save weight, the UART connections are spread out over the board and are not, as usual, clustered in a 6-pin connector. The connection holes are just big enough for standard breadboard jumper wires, so a connection to the MSP430 Launchpad is easily set up.

Weight watching

When designing an earring, weight is an important factor. A little investigation (easy to imagine) shows that an earring shouldn't weigh significantly more than 13 grams in

order to be comfortable to wear. Since the design is electrical, the major impact on the total weight is caused by the power supply, consisting of a (freely selectable) CR2016, CR2025 or CR2032 button cell lithium battery. Around 3 grams for the biggest one, the CR2032. The PCB, being a circular form with a diameter of 3 cm, adds another 2 grams. The remaining 8 grams are then available for the components.

Figure 1. Besides the µC, the circuit only comprises a voltage regulator, two switches, LEDs, as well as few passive components.

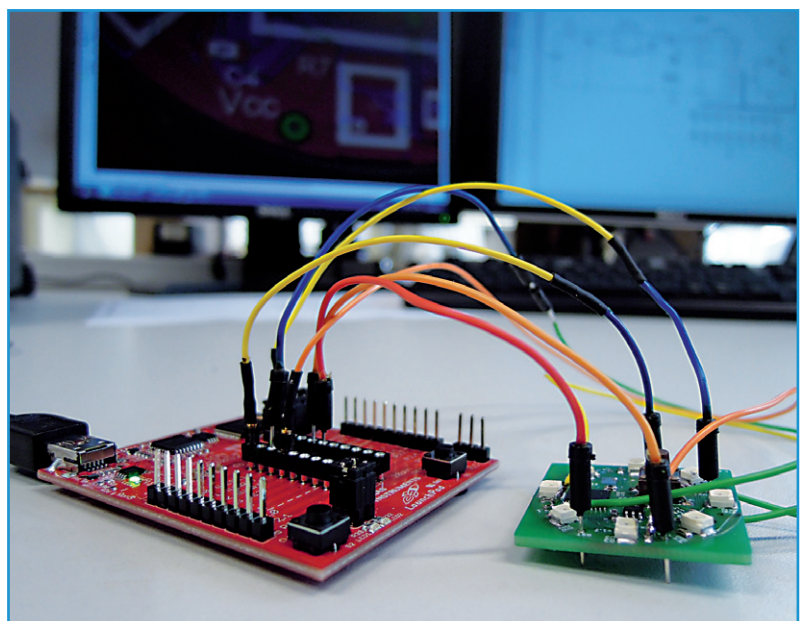

Design-wise 0402-shaped capacitors and resistors are used, which are quite small and therefore also quite lightweight.

When operational, the total circuit uses 3 mA on average. This means a 90 mAh CR2016 battery will last about 30 hours. The more powerful 225 mAh CR2032 lasts around 75 hours. Even if you are a true party animal, this seems to be more than enough!

A tip for the tip

The use of such tiny components disallows manual soldering. For this reason, each LED earring comes already populated, with the exception of the battery holder. Earrings can be ordered directly from **Elektor PCB Service** [5].

To get the earring finished, and be able to attach the battery successfully, you will have to 'drop' a solder blob over the big battery contact, in order to avoid short circuits with other tracks. In this way, the battery will be at a safe distance from the PCB surface and also make the earring more robust. Afterwards, it will be ready to get the battery clip soldered. Check your tinkering against **figure 2**. Now just place the battery (with the negative terminal against the PCB), and you're ready to rock!

(120607)

Text revision and additions:
Jaime González-Arintero

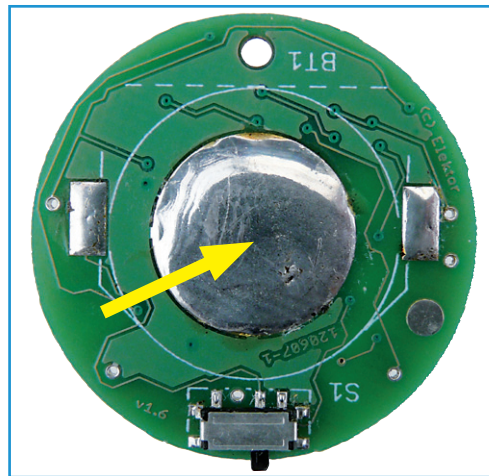

Figure 2. A small solder blob is enough to avoid short circuits with other contacts.

Available from elektor•labs:

- 2 software files (clockwise and anticlockwise patterns for LEDs)
- Schematics file (Eagle, PDF and PNG image)
- PCB artwork file (Eagle and PDF)

Internet Links:

- [1] www.youtube.com/watch?v=gY95Yvs6VD8
- [2] http://en.wikipedia.org/wiki/Pierce_oscillator
- [3] www.elektor-projects.com/Elektor.POST/2013/01
- [4] www.ti.com/tool/msp-exp430g2
- [5] www.elektorpcbservice.com

Component List

Resistors

- R1 to R8 = 220 Ω, 0603
- R9 = 68 k, 0402
- R10 = 390 k, 0402
- R11 = 10 k, 0402

Capacitors

- C1, C2 = 1μF, 0603
- C3, C4 = 22pF, 0402 (optional)
- C5 = 22 nF, 0402

Semiconductors

- IC1 = MSP430G2152, 20TSSOP, 16 bits
- IC2 = LDO 2.8V, 5SOT753
- D1 to D8 = SMD LED, red, PLCC2, 1.12 CD, 2.05V

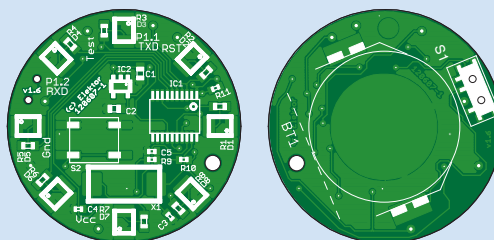

Miscellaneous

- X1 = quartz, 4 MHz (optional)
- S1 = side-actuated SMD switch
- S2 = SMD push button, 1.6N, 50mA
- BT1 = battery clip for CR2032

*Fully assembled earrings: order #120607