

Doc. version :	0
Total pages :	21
Date :	2003.4.9

Product Specification

1.5" COLOR TFT-LCD MODULE

MODEL NAME: A015AN03 V1

<◆> Preliminary Specification

< > Final Specification

Note: The content of this specification is subject to change.

© 2002 AU Optronics
All Rights Reserved,
Do Not Copy.

Contents:

A. Physical specification	P3
B. Electrical specifications	P4
1. Pin assignment.....	P4
a. TFT-LCD panel driving section.....	P5
b. Backlight driving section.....	P5
2. Absolute maximum ratings.....	P5
3. Electrical characteristics.....	P6
a. Typical operating conditions.....	P6
b. Current consumption.....	P6
c. Backlight driving conditions.....	P6
4. AC Timing.....	P7
a. Timing conditions.....	P7
b. Timing diagram.....	P7
C. Optical specifications	P8
D. Reliability test items	P10
E. Packing form	P11

Appendix:

Fig.1 Outline dimension of TFT-LCD module.....	P 12
Fig.2 Sampling clock timing.....	P 13
Fig.3 Horizontal display timing range (Normal scanning mode).....	P 14
Fig.4 - (a) Horizontal timing.	P 15
Fig.4-(b) Detail horizontal timing.....	P 16
Fig.5 Vertical shift clock timing.....	P 17
Fig.6-(a) Vertical timing (Normal scanning mode).....	P 18
Fig.6-(b) Vertical timing (Reverse scanning mode).....	P 19

A. Physical specifications

NO.	Item	Specification	Remark
1	Display resolution(dot)	280(W) ×220(H)	
2	Active area(mm)	29.54(W) ×22.22(H)	
3	Screen size(inch)	1.45(Diagonal)	
4	Dot pitch(mm)	0.1055(W) ×0.101(H)	
5	Color configuration	R. G. B. delta	
6	Overall dimension(mm)	40.1(W) ×34.6(H) ×3.9(D)	Note 1
7	Weight(g)	10 Typ.	

Note 1: Refer to Fig. 1

B. Electrical specifications

1. Pin assignment

a. TFT-LCD panel driving section

Pin no	Symbol	I/O	Description	Remark
1	GND	-	Ground for logic circuit	
2	V _{CC1}	I	Supply voltage of logic control circuit for scan driver	
3	V _{GL}	I	Negative power for scan driver	
4	V _{GH}	I	Positive power for scan driver	
5	STVR	I/O	Vertical start pulse	Note 1
6	STVL	I/O	Vertical start pulse	Note 1
7	CKV	I	Shift clock input for scan driver	
8	U/D	I	Up/Down scan control input	Note 1,2
9	OEV	I	Output enable input for scan driver	
10	VCOM	I	Common electrode driving signal	
11	VCOM	I	Common electrode driving signal	
12	L/R	I	Left/Right scan control input	Note 1,2
13	Q1H	I	Analog signal rotate input	
14	OEH	I	Output enable input for data driver	
15	STHL	I/O	Start pulse for horizontal scan line	Note 1
16	STHR	I/O	Start pulse for horizontal scan line	Note 1
17	CPH3	I	Sampling and shifting clock pulse for data driver	
18	CPH2	I	Sampling and shifting clock pulse for data driver	
19	CPH1	I	Sampling and shifting clock pulse for data driver	
20	V _{CC2}	I	Supply voltage of logic control circuit for data driver	
21	GND	-	Ground for logic circuit	
22	VR	I	Alternated video signal input(Red)	
23	VG	I	Alternated video signal input(Green)	
24	VB	I	Alternated video signal input(Blue)	
25	AV _{DD}	I	Supply voltage for analog circuit	
26	AV _{SS}	-	Ground for analog circuit	

Note 1: Selection of scanning mode

Mode	Setting of scan control input		IN/OUT state For start pulse				Scanning direction
	U/D	L/R	STVR	STVL	STHR	STHL	
Normal mode	L	H	OUT	IN	OUT	IN	From up to down, and from left to right.
Reverse mode	H	L	IN	OUT	IN	OUT	From down to up, and from right to left.

IN: Input; OUT: Output.

Note 2 : Definition of scanning direction.
Refer to figure as below:

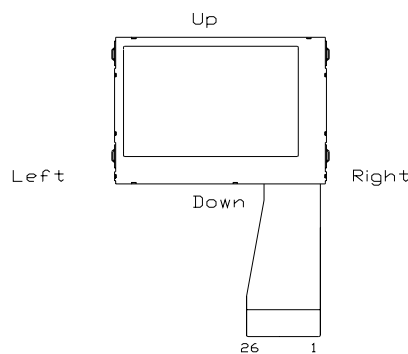

b. Backlight driving section (Refer to Fig.1)

No.	Symbol	I/O	Description	Remark
1	HI		Power supply for backlight unit (High voltage)	
2	GND	-	Ground	

2. Absolute maximum ratings

Item	Symbol	Condition	Min.	Max.	Unit	Remark
Power voltage	V_{CC}	GND=0	-0.3	7	V	V_{CC1}, V_{CC2}
	AV_{DD}	$AV_{SS}=0$	-0.3	7	V	
	V_{GH}	GND=0	-0.3	21	V	
	V_{GL}		-17	0.3	V	
	$V_{GH} - V_{GL}$		-	33	V	
Input signal voltage	V_i		-0.2	$AV_{DD} + 0.2$	V	Note 1
	V_I		-0.3	$V_{CC} + 0.3$	V	Note 2
	VCOM		-2.9	5.2	V	
Operating temperature	Topa		0	60	°C	Ambient temperature
Storage temperature	Tstg		-25	80	°C	Ambient temperature
Backlight voltage	V_L		-0.3		V	

Note 1: VR, VG, VB.

Note 2: STHL, STHR, Q1H, OEH, L/R, CPH1~CPH3, STVR, STVL, OEV, CKV, U/D.

3. Electrical characteristics

a. Typical operating conditions (GND=AVss=0V)

Item	Symbol	Min.	Typ.	Max.	Unit	Remark
Power supply	V_{CC}	3	5	5.2	V	V_{CC1} ; V_{CC2}
	AV_{DD}	4.65	5	5.35	V	
	V_{GH}	13.5	15	16.5	V	
	V_{GLAC}	-	4.6	-	Vp-p	AC component of V_{GL} . Note 1
	V_{GL_H}	-11	-10	-9	V	High level of V_{GL} .
Video signal Amplitude (VR, VG, VB)	V_{iA}	$AV_{SS} + 0.4$	-	$AV_{DD} - 0.4$	V	Note 2
	V_{iAC}	-	3	3.8	V	AC component
	V_{iDC}	-	$AV_{DD} / 2$	-	V	DC component
VCOM	V_{CAC}	-	4.6	-	Vp-p	AC component, Note 3
	V_{CDC}	0.45	0.75	1.05	V	DC component, Note 4
Input Signal voltage	H Level	V_{IH}	$0.8V_{CC}$	-	V_{CC}	Note 5
	L Level	V_{IL}	0	-	$0.2V_{CC}$	

Note 1: The same phase and amplitude with common electrode driving signal (VCOM).

Note 2: Refer to Fig.4 - (a).

Note 3: The brightness of LCD panel could be adjusted by the adjustment of the AC component of VCOM.

Note 4: V_{CDC} could be adjusted so as to minimize vertical straight line, flicker and maximum contrast on each module.

Note 5: STHL, STHR, Q1H, OEH, L/R, CPH1~CPH3, STVR, STVL, OEV, CKV, U/D.

Note 6: Be sure to apply GND, V_{CC} and V_{GL} (V_{GL} must lower than 0 volt) to the LCD first, and then apply V_{GH} .

b. Current consumption (GND=AVss=0V)

Parameter	Symbol	Condition	Min.	Typ.	Max.	Unit	Remark
Current for driver	I_{GH}	$V_{GH}=15V$	-	0.3	0.8	mA	
	I_{GL}	$V_{GL_H}=-10V$	-	-0.6	-1	mA	
	I_{CC}	$V_{CC}=5V$	-	0.8	2	mA	V_{CC1} ; V_{CC2}
	I_{DD}	$AV_{DD}=5V$	-	2.5	8	mA	

c. Backlight driving conditions

Parameter	Symbol	Min.	Typ.	Max.	Unit	Remark
Backlight current			20		mA	
Backlight voltage	V_L			8	V	
LED Life Time	L_L	10000			Hr	Note 1,2

Note 1 : $T_a = 25^\circ C$, $I_L = 20mA$

Note 2 : Brightness to be decreased to 50% of the initial value.

4. AC Timing

a. Timing conditions

Parameter	Symbol	Min.	Typ.	Max.	Unit.	Remark
Rising time	t_r	-	-	10	ns	Note 1
Falling time	t_f	-	-	10	ns	Note 1
High and low level pulse width	t_{CPH}	450	500	550	ns	CPH1~CPH3
CPH pulse duty	t_{CWH}	40	50	60	%	CPH1~CPH3
CPH pulse delay	t_{C12} t_{C23} t_{C31}	70	$t_{CPH}/3$	$t_{CPH}/2$	ns	CPH1~CPH3
STH setup time	t_{SUH}	70	-	-	ns	STHR,STHL
STH hold time	t_{HDH}	350	-	-	ns	STHR,STHL
STH pulse width	t_{STH}	-	1	-	t_{CPH}	STHR,STHL
STH period	t_H	61.5	63.5	65.5	μs	STHR,STHL
OEH pulse width	t_{OEH}	-	3	-	t_{CPH}	OEH
Sample and hold disable time	t_{DIS1}	-	20	-	t_{CPH}	
OEV pulse width	t_{OEV}	-	5	-	t_{CPH}	OEV
CKV pulse width	t_{CKV}	2	6	10	t_{CPH}	CKV
Clean enable time	t_{DIS2}	-	4	-	t_{CPH}	
Horizontal display start	t_{SH}	-	4	-	$t_{CPH}/3$	
Horizontal display timing range	t_{DH}	-	280	-	$t_{CPH}/3$	
STV setup time	t_{SUV}	400	-	-	ns	STVL,STVR
STV hold time	t_{HDV}	400	-	-	ns	STVL,STVR
STV pulse width	t_{STV}	-	-	1	t_H	STVL,STVR
Horizontal lines per field	t_V	256	262	268	t_H	
Vertical display start	t_{SV}	-	10	-	t_H	
Vertical display timing range	t_{DV}	-	220	-	t_H	
VCOM rising time	t_{rCOM}	-	-	6	μs	
VCOM falling time	t_{fCOM}	-	-	6	μs	
VCOM delay time	t_{DCOM}	-	-	6	μs	
RGB delay time	t_{DRGB}	-	-	6	μs	

Note 1: For all of the logic signals..

b. Timing diagram

Please refer to the attached drawing, from Fig.2 to Fig.6.

C. Optical specification (Note 1,Note 2, Note 3)

Item	Symbol	Condition	Min.	Typ.	Max.	Unit	Remark
Response time	Rise	$\theta = 0^\circ$	-	25	50	ms	Note 4
	Fall		-	30	60	ms	
Contrast ratio	CR	At optimized viewing angle	60	150	-		Note 5,6
Viewing angle	Top	$CR \geq 10$	10	-	-	deg.	Note 7
	Bottom		30	-	-		
	Left		40	-	-		
	Right		40	-	-		
Brightness	Y_L	$\theta = 0^\circ$	170	200	-	cd/m^2	Note 8
White chromaticity	X	$\theta = 0^\circ$	0.27	0.31	0.35		
	y	$\theta = 0^\circ$	0.30	0.35	0.40		

Note 1. Ambient temperature =25°C . And backlight current $I_L=20$ mA

Note 2. To be measured in the dark room.

Note 3.To be measured on the center area of panel with a field angle of 1°by Topcon luminance meter BM-7, after 10 minutes operation.

Note 4. Definition of response time:

The output signals of photo detector are measured when the input signals are changed from “black” to “white”(falling time) and from “white” to “black”(rising time), respectively. The response time is defined as the time interval between the 10% and 90% of amplitudes. Refer to figure as below.

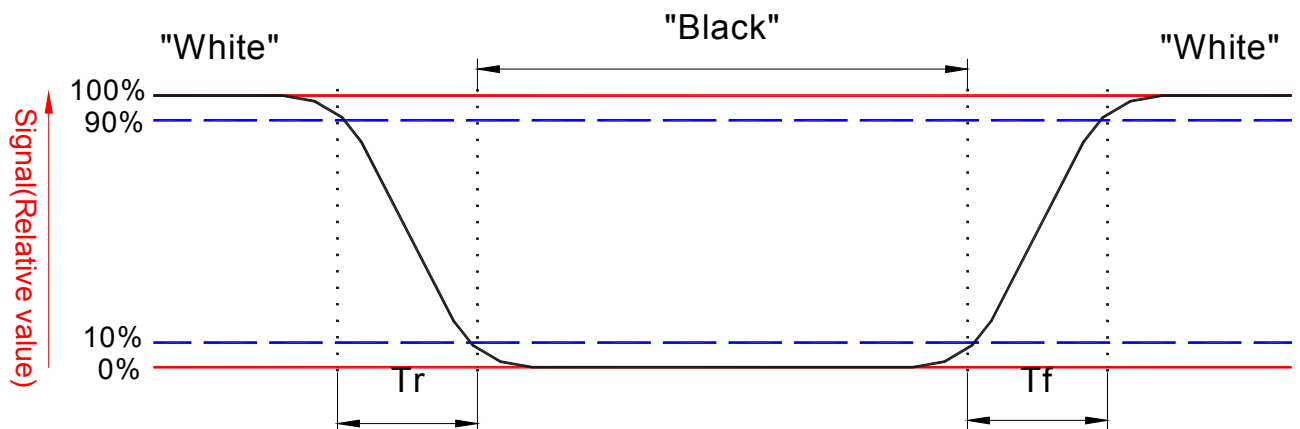

Note 5. Definition of contrast ratio:
Contrast ratio is calculated with the following formula.

$$\text{Contrast ratio (CR)} = \frac{\text{Photo detector output when LCD is at "White" state}}{\text{Photo detector output when LCD is at "Black" state}}$$

Note 6. White $V_i = V_{i50} \mp 1.5V$

Black $V_i = V_{i50} \pm 2.0V$

"±" Means that the analog input signal swings in phase with COM signal.

"∓" Means that the analog input signal swings out of phase with COM signal.

V_{i50} : The analog input voltage when transmission is 50%

The 100% transmission is defined as the transmission of LCD panel when all the input terminals of module are electrically opened.

Note 7. Definition of viewing angle:

Refer to figure as below.

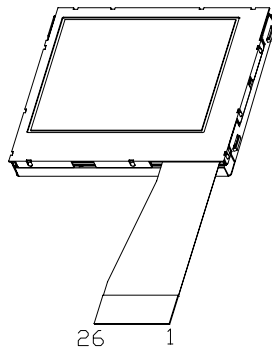

Note 8. Measured at the center area of the panel when all the input terminals of LCD panel are electrically opened.

D. Reliability test items:

No.	Test items	Conditions	Remark
1	High temperature storage	Ta= 80°C 240Hrs	
2	Low temperature storage	Ta= -25°C 240Hrs	
3	High temperature operation	Ta= 60°C 240Hrs	
4	Low temperature operation	Ta= 0°C 240Hrs	
5	High temperature and high humidity	Ta= 60°C . 90% RH 240Hrs	Operation
6	Heat shock	-25°C~80°C/50 cycle 2Hrs/cycle	Non-operation
7	Electrostatic discharge	±200V,200pF(0Ω), once for each terminal	Non-operation
8	Vibration	Frequency range : 10~55Hz Stoke : 1.5mm Sweep : 10~55Hz~10Hz 2 hours for each direction of X,Y,Z (6 hours for total)	Non-operation JIS C7021, A-10 condition A
9	Mechanical shock	100G . 6ms, ±X,±Y,±Z 3 times for each direction	Non-operation JIS C7021, A-7 condition C
10	Vibration (with carton)	Random vibration: 0.015G ² /Hz from 5~200Hz -6dB/Octave from 200~500Hz	IEC 68-34
11	Drop (with carton)	Height: 60cm 1 corner, 3 edges, 6 surfaces	

Note: Ta: Ambient temperature.

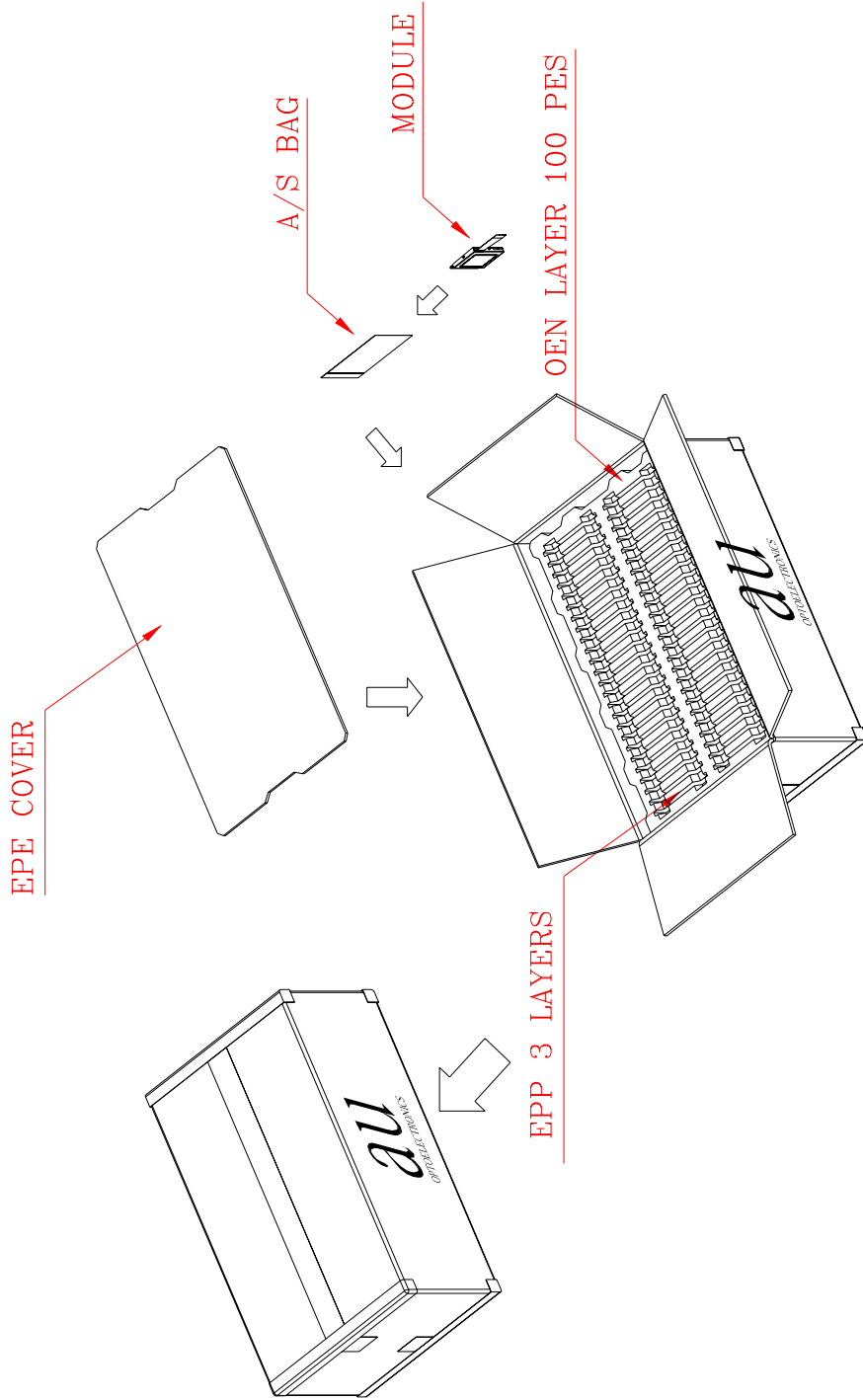

Max. Capacity: 300 Pcs
Max. Weight: 7 Kg
MEAS.:600mm*353mm*210mm

- NOTES:
1.General tolerance is ± 0.3
2.The bending radius of FPC should be larger than 0.6.

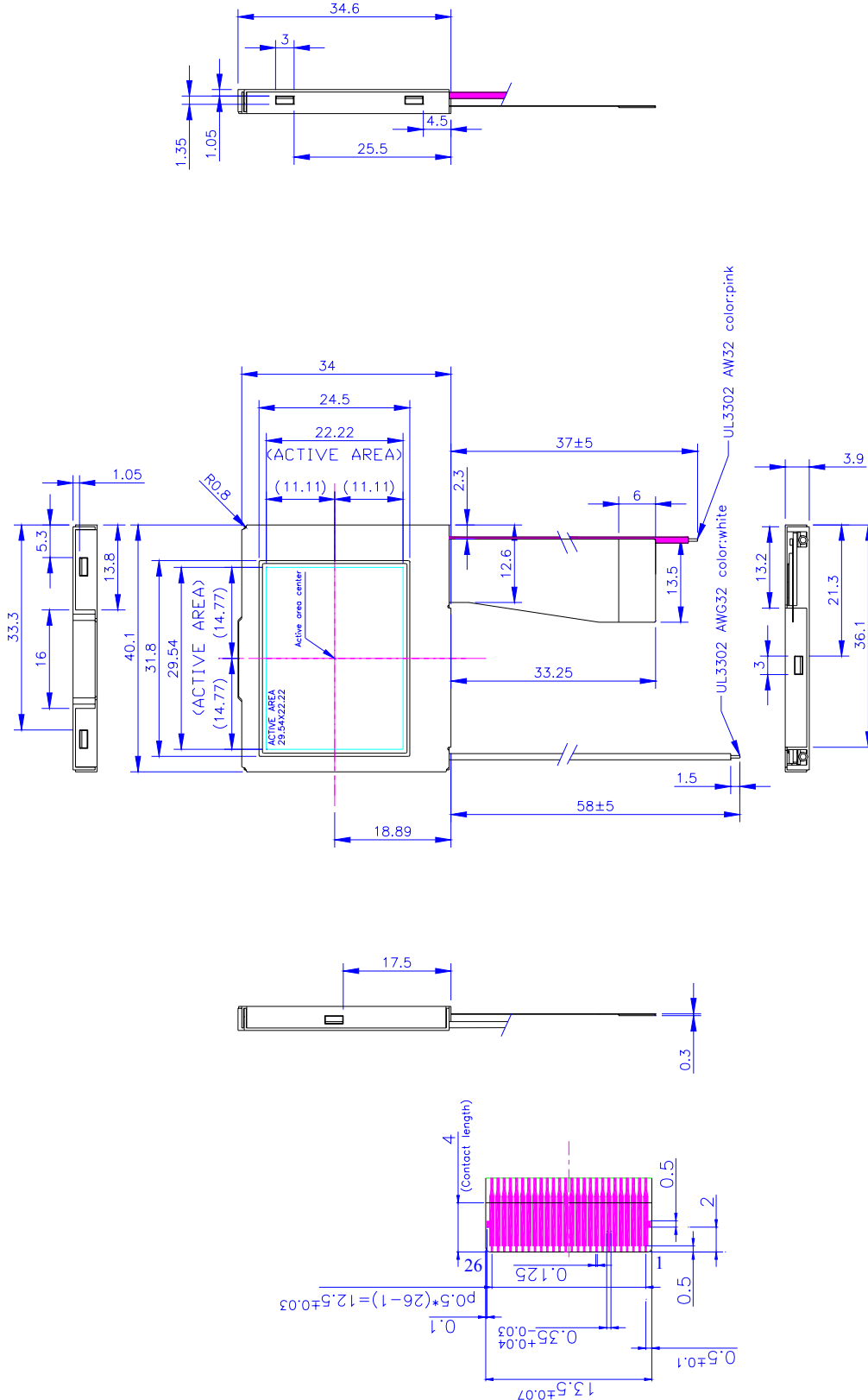

Fig.1 Outline dimension of TFT-LCD module

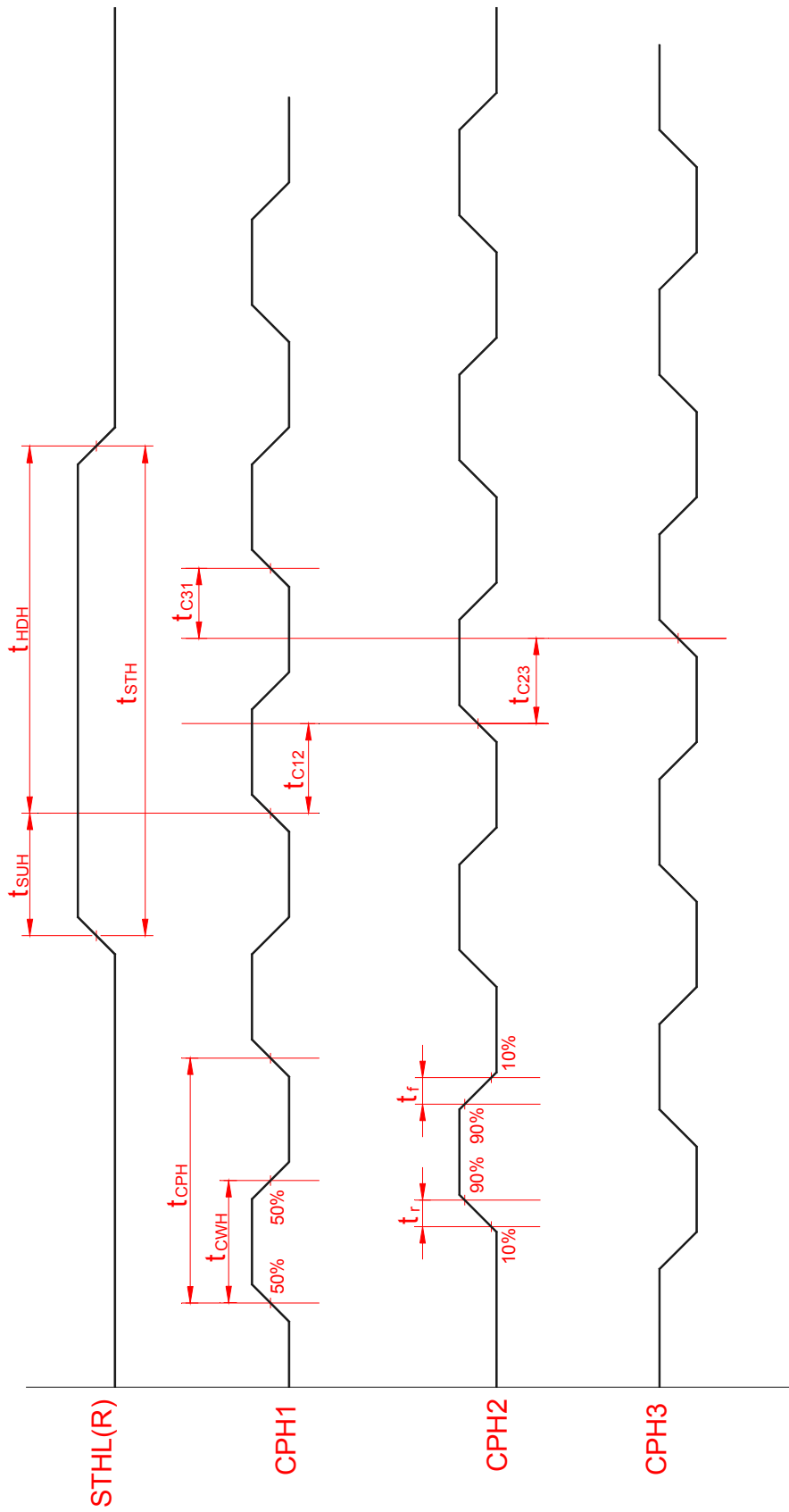

Fig. 2 Sampling clock timing

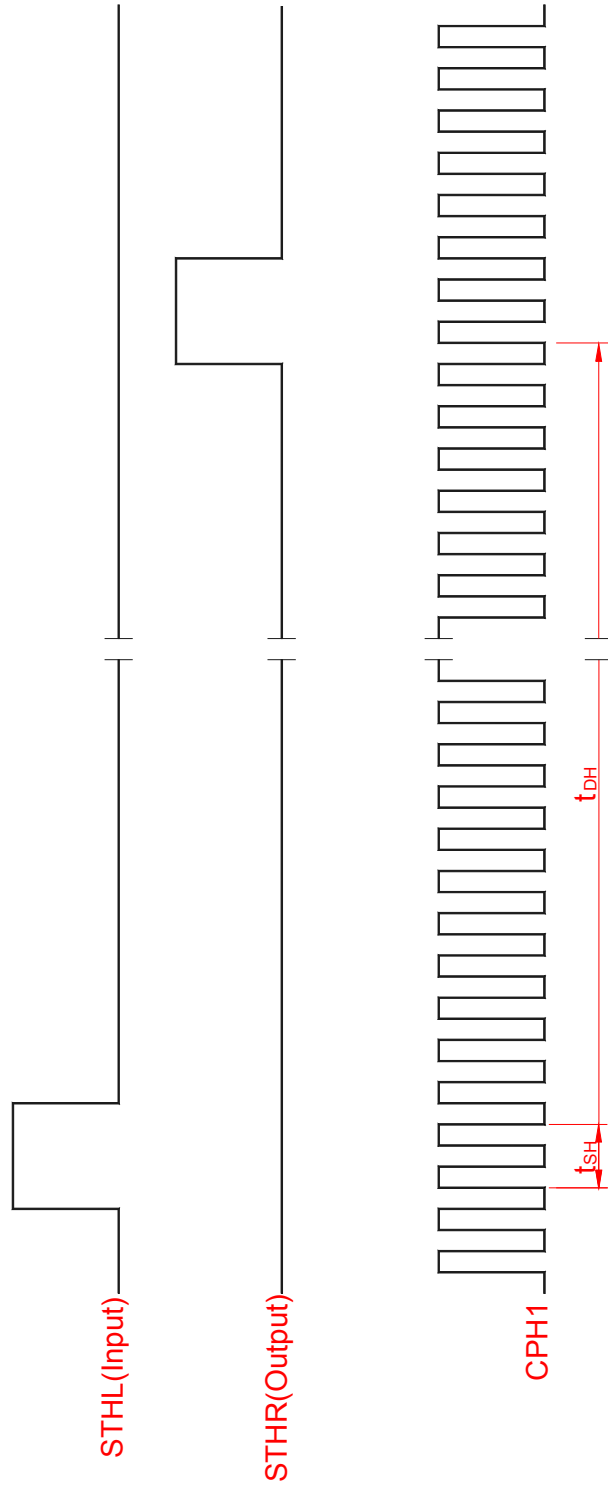

Fig. 3 Horizontal display timing range(Normal scanning mode)

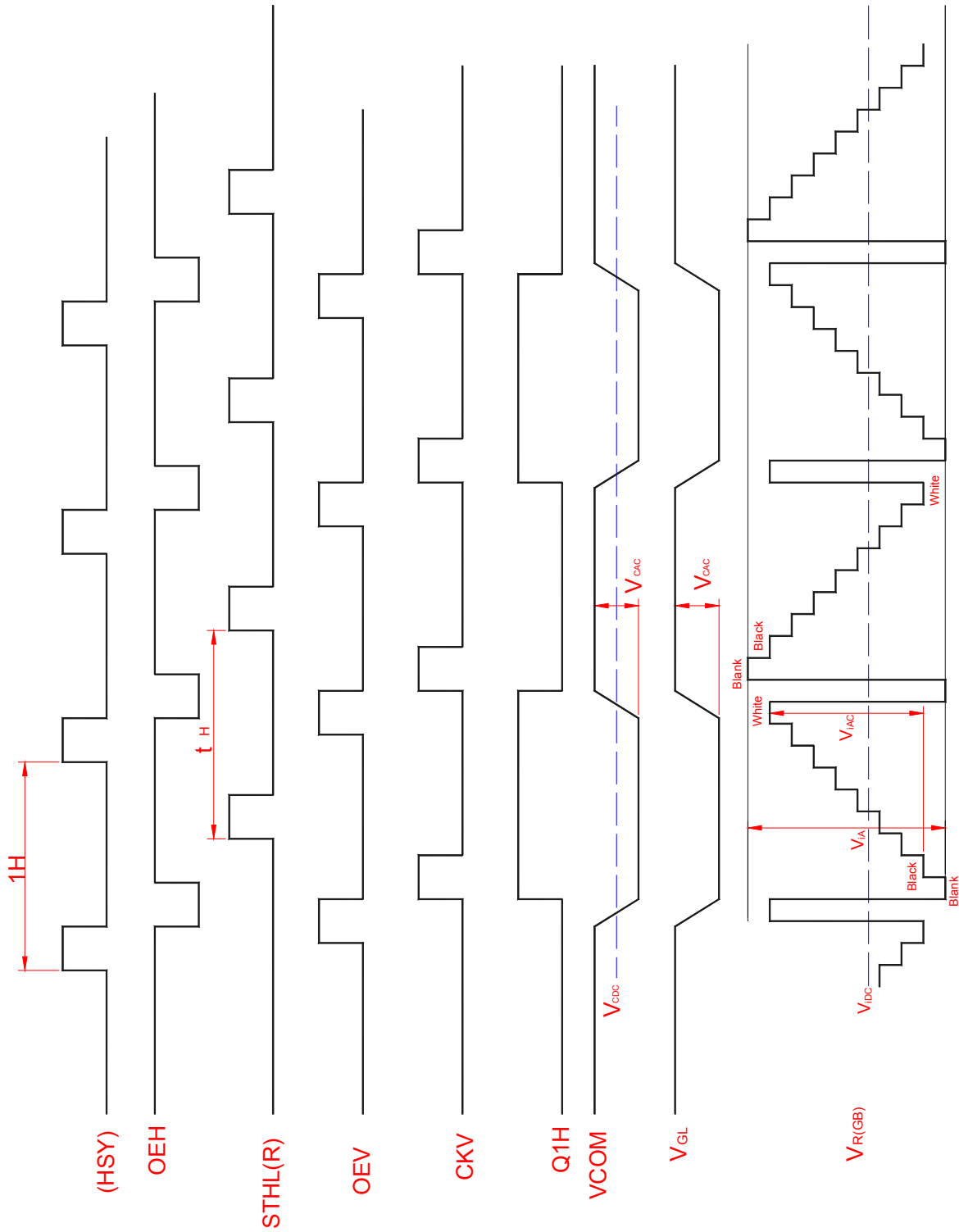

Fig.4-(a) Horizontal timing

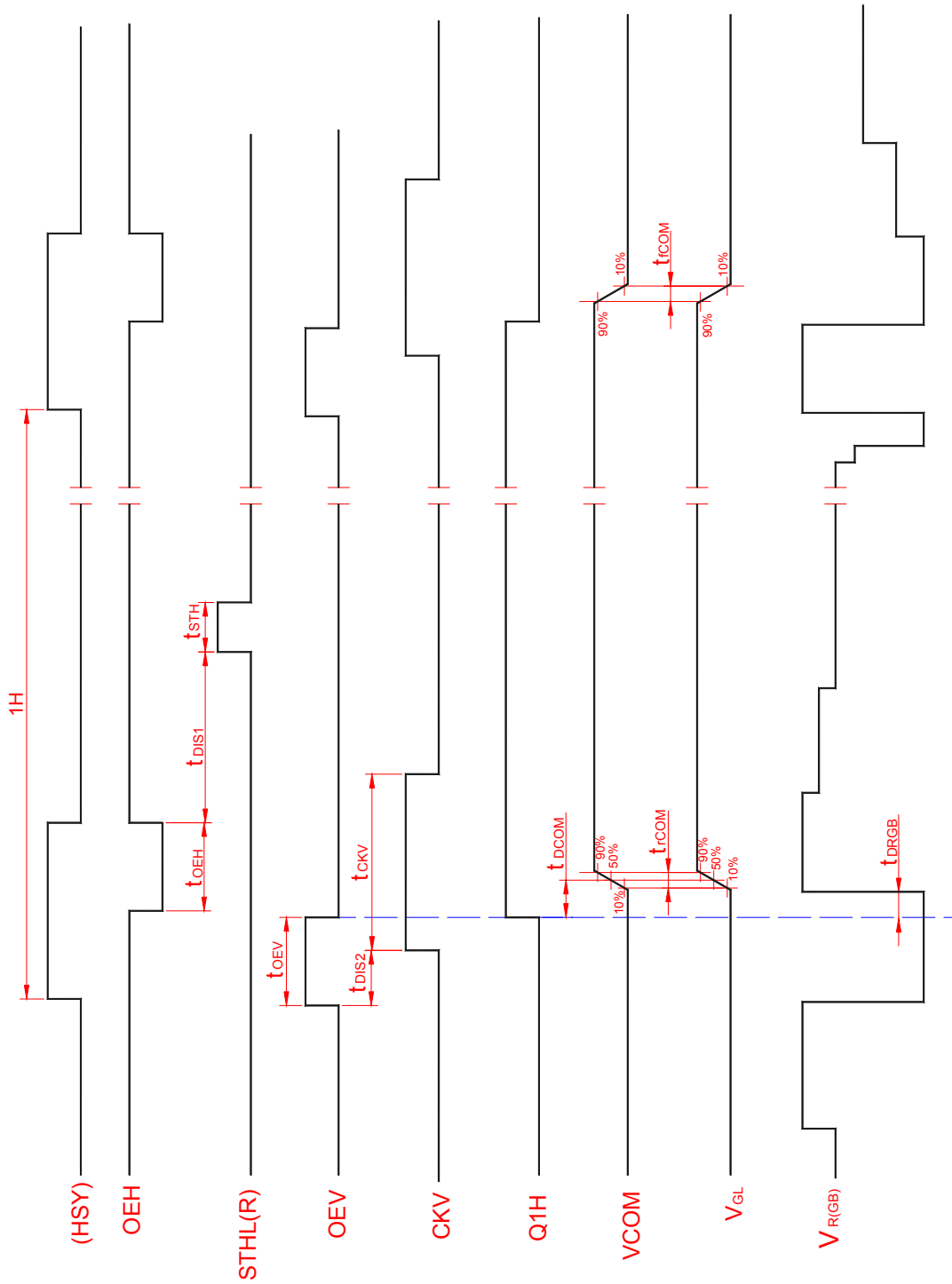

Fig. 4-(b) Detail horizontal timing

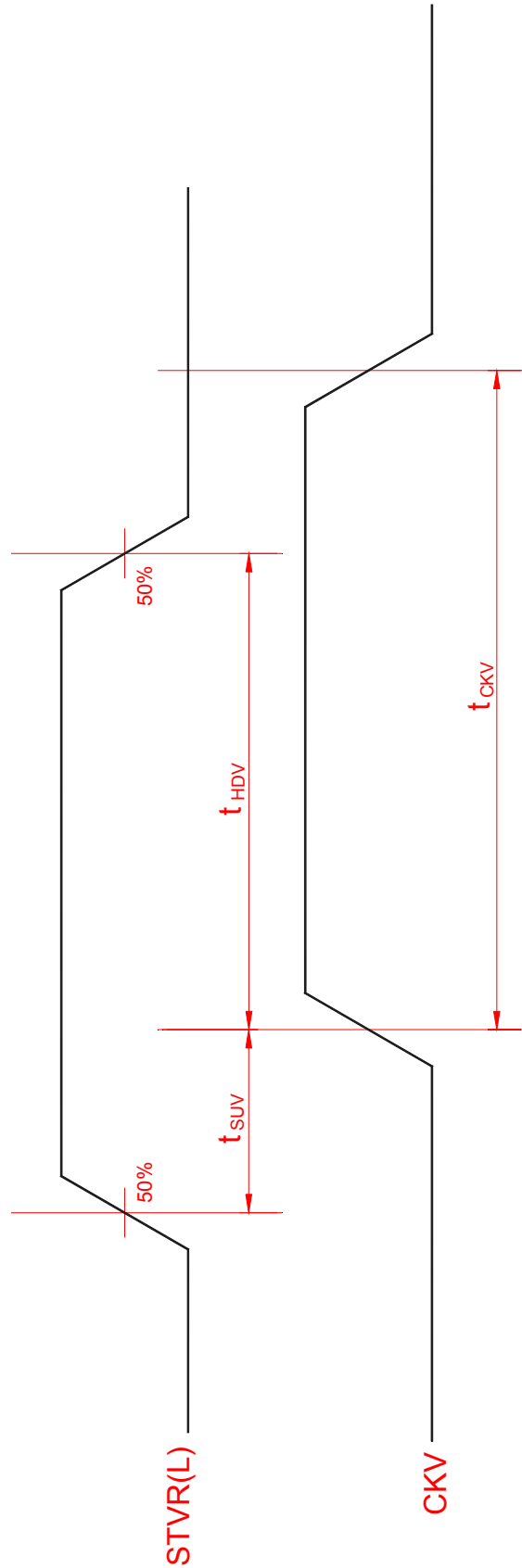

Fig.5 Vertical shift clock timing

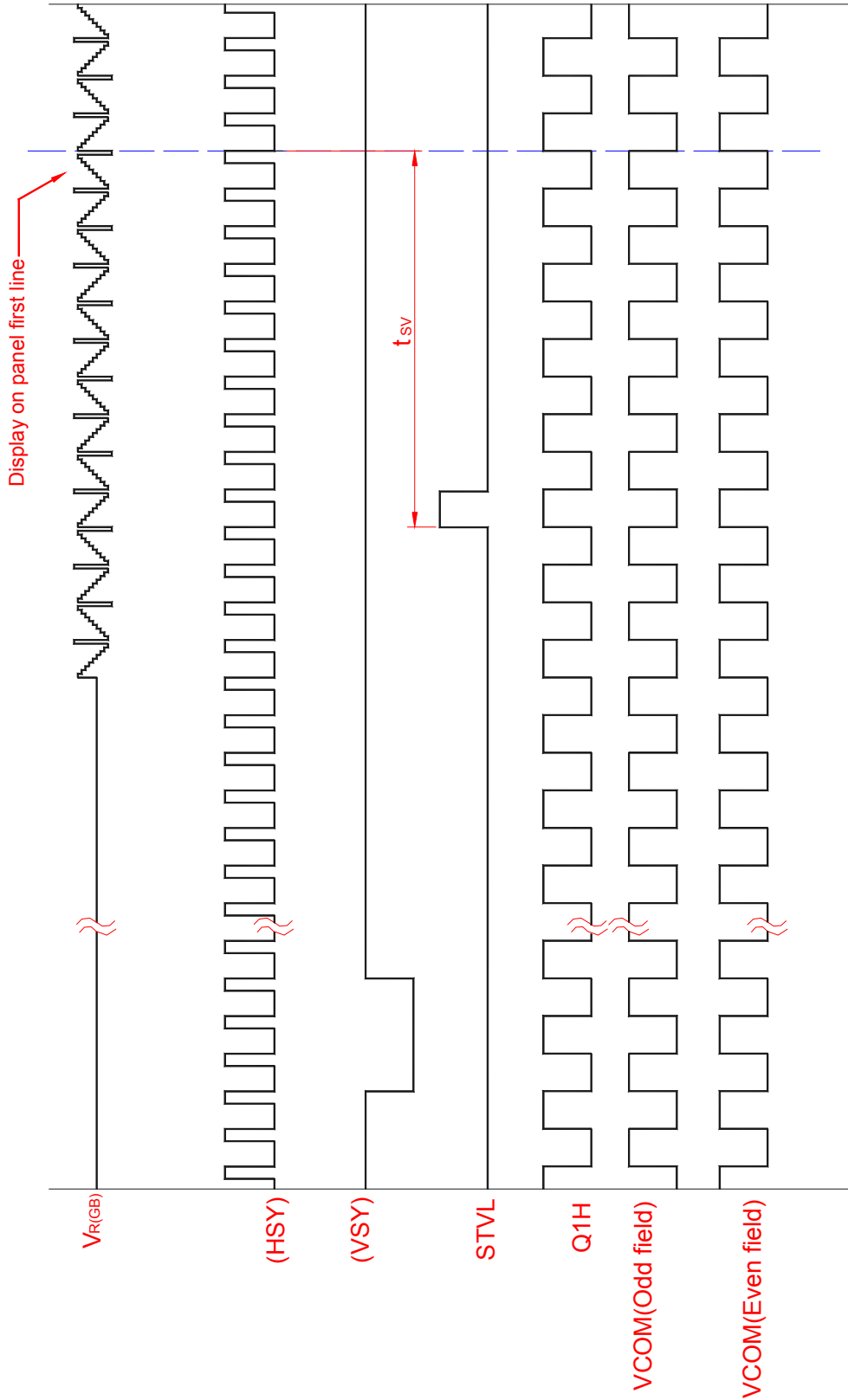

Fig.6-(a) Vertical timing (From up to down)

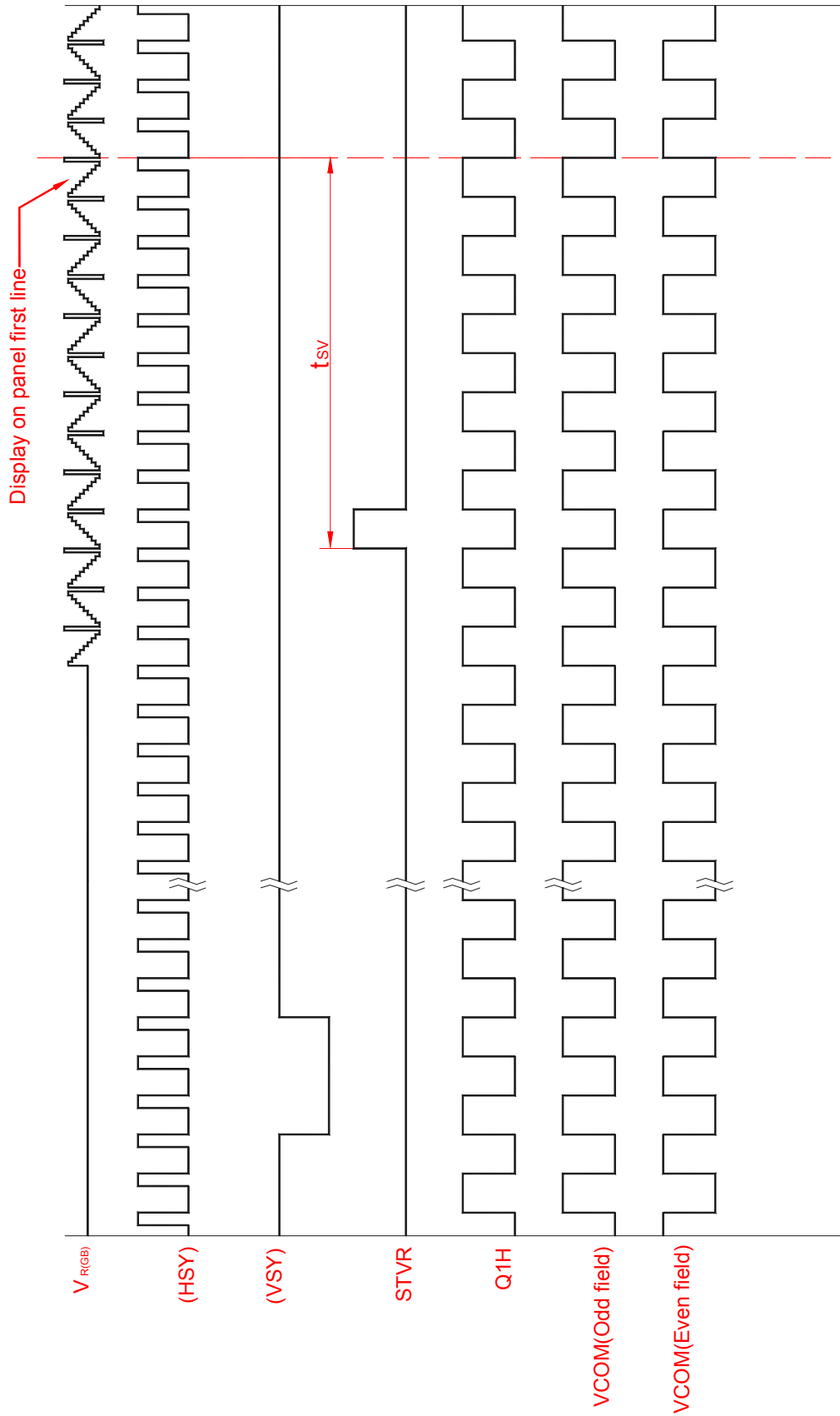

Fig.6-(b) Vertical timing (From down to up)