

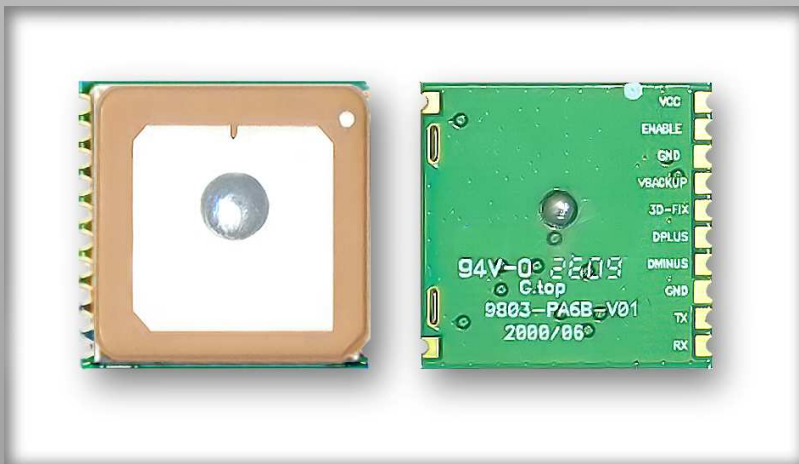

GlobalTop Technology Inc.

# FGPMMOPA6B GPS Module Data sheet

Revision: A07



FGPMMOPA6B is a 66-channel GPS Engine Board, Antenna Module with MTK chipset that is fully pin compatible with FGPMMOPA6

This document is the exclusive property of GlobalTop Tech Inc. and should not be distributed, reproduced, into any other format without prior permission of GlobalTop Tech Inc. Specifications subject to change without prior notice.

**Copyright © 2011 GlobalTop Technology Inc. All Rights Reserved.**

No.16 Nan-ke 9<sup>th</sup> Rd, Science-Based Industrial Park, Tainan, 741, Taiwan, R.O.C.

Tel: +886-6-5051268 / Fax: +886-6-5053381 / Email: [sales@gtop-tech.com](mailto:sales@gtop-tech.com) / Web: [www.gtop-tech.com](http://www.gtop-tech.com)



## Version History

**Title:** GlobalTop FGPMMOPA6B Datasheet

**Subtitle:** GPS Module

**Doc Type:** Datasheet

**Doc Id:** GR9903-DS000E

Revision	Date	Description
A00	2009-07-10	First Release
A01	2009-07-23	Add RoHS Compliant
A02	2010-03-23	Add Packing and Handling Section, plus SMT and soldering cautions
A03	2010-04-30	Page 10: Reference design circuit Page 17: Modify for RMC Magnetic Variation data
A04	2010-06-11	Page 7: Recommend PCB Layout pad Page 26: Cautionary Note on SMT production
A05	2010-11-29	New Layout Page 8: Add recommended PCB pad layout Page 31: Add more cautions on reflow-soldering
A06	2011-05-13	Update Company contact information Firmware Customization Services Add application description about 3D-Fix Pin (Pin 5) Notice : SBAS only support under 5Hz
A07	2011-07-05	Page15: Update USB Parameter and Condition of DC Characteristics

## Table of Contents

---

<b>1. Functional Description .....</b>	<b>4</b>
1.1 Overview .....	4
1.2 Highlights and Features .....	4
1.3 System Block Diagram.....	5
<b>2. Specifications .....</b>	<b>6</b>
2.1 Mechanical Dimension .....	6
2.2 Recommended PCB pad Layout.....	8
2.3 Pin Configuration .....	10
2.4 Pin Assignment .....	10
2.5 Description of I/O Pin .....	11
2.6 Specification List .....	13
2.7 DC Characteristics .....	15
<b>3. Protocols .....</b>	<b>16</b>
3.1 NMEA Output Sentences .....	16
3.2 MTK NMEA Command Protocols.....	21
3.3 Firmware Customization Services.....	22
<b>4. Reference Design .....</b>	<b>23</b>
4.1 Reference Design Circuit.....	23
<b>5. Packing and Handling.....</b>	<b>24</b>
5.1 Moisture Sensitivity .....	24
5.2 Packing .....	25
5.3 Storage and Floor Life Guideline.....	27
5.4 Drying.....	27
5.5 ESD Handling.....	28
<b>6. Reflow Soldering Temperature Profile .....</b>	<b>29</b>
6.1 SMT Reflow Soldering Temperature Profile.....	29
6.2 Cautions on Reflow Soldering with Patch Antenna .....	30
6.3 Manual Soldering.....	33
<b>7. Contact Information.....</b>	<b>33</b>

# 1. Functional Description

## 1.1 Overview

The FGPMMOPA6B is an ultra-compact POT (Patch On Top) GPS Module. This POT GPS receiver provides a solution that is high in position and speed accuracy performances, with high sensitivity and tracking capabilities in urban conditions. The GPS chipset inside the module is powered by MediaTek Inc., the world's leading digital media solution provider and the largest fab-less IC company in Taiwan. The module can support up to 66 channels, and is designed for small-form-factor device. It is suitable for every GPS-related application, such as:

- Fleet Management/Asset Tracking
- LBS (location base service) and AVL system
- Security system
- Hand-held device for personal positioning and travel navigation

## 1.2 Highlights and Features

- MediaTek MT3329 Single Chip
- L1 Frequency, C/A code, 66 channels
- Support up 210 PRN channels
- Jammer detection and reduction
- Multi-path detection and compensation
- Dimension: 16mm x 16mm x 6mm
- Patch Antenna Size: 15mm x 15mm x 4mm
- High Sensitivity: Up to -165 dBm tracking, superior urban performances<sup>1</sup>
- Position Accuracy:
  - Without aid: 3m 2D-RMS
  - DGPS (SBAS(WAAS,EGNOS,MSAS)):2.5m 2D-RMS<sup>2</sup>
- Low Power Consumption: 48mA @ acquisition, 37mA @ tracking
- Low Shut-Down Power Consumption: 15uA, typical
- DGPS(WAAS/EGNOS/MSAS/GAGAN) support (Default: Enable)
- Max. Update Rate: up to 10Hz (Configurable by firmware)
- USB Interface support without extra bridge IC
- FCC E911 compliance and AGPS support (Offline mode : EPO valid up to 14 days )
- RoHS Compliant

<sup>1</sup> Reference to GPS chipset specification

<sup>2</sup>: SBAS can only be enabled when update rate is less than or equal to 5Hz.

### 1.3 System Block Diagram

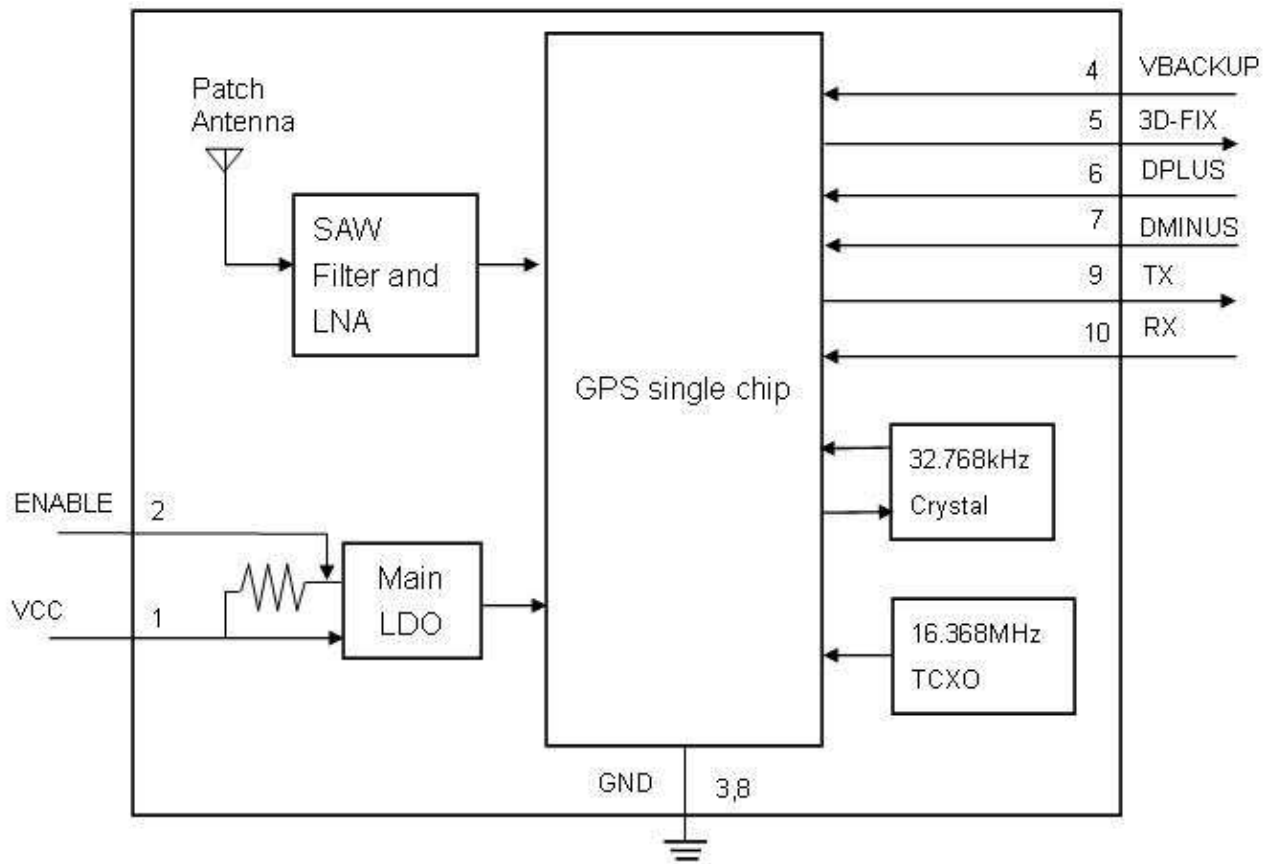

## 2. Specifications

### 2.1 Mechanical Dimension

Dimension: (Unit: mm, Tolerance: +/- 0.1mm)

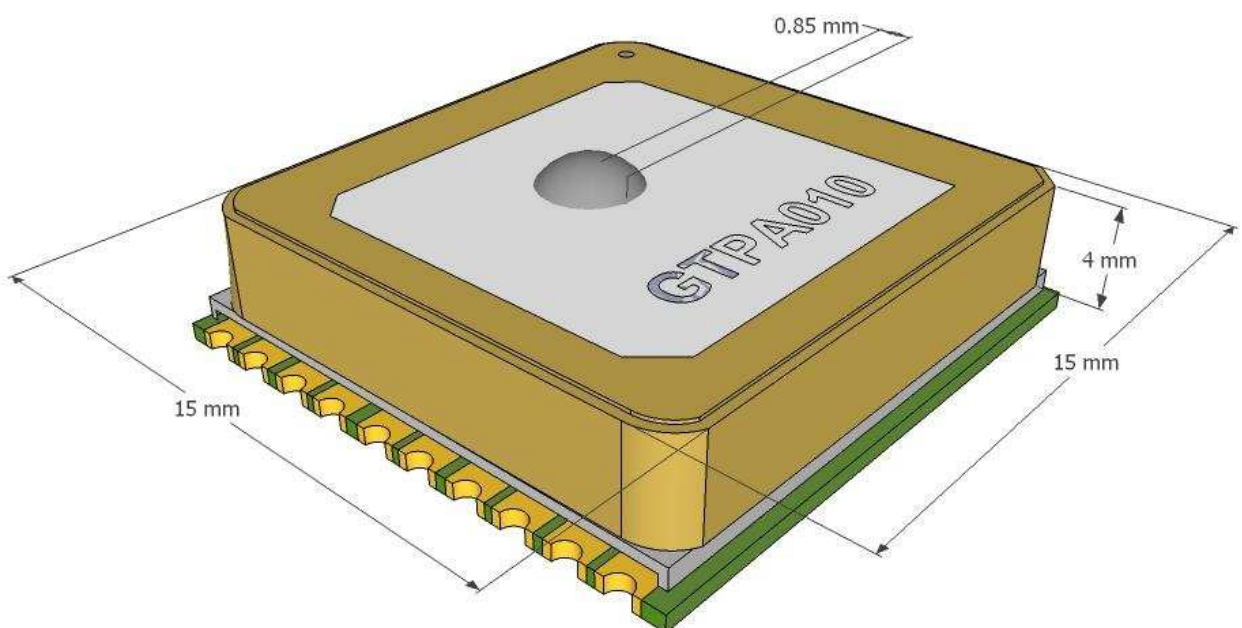
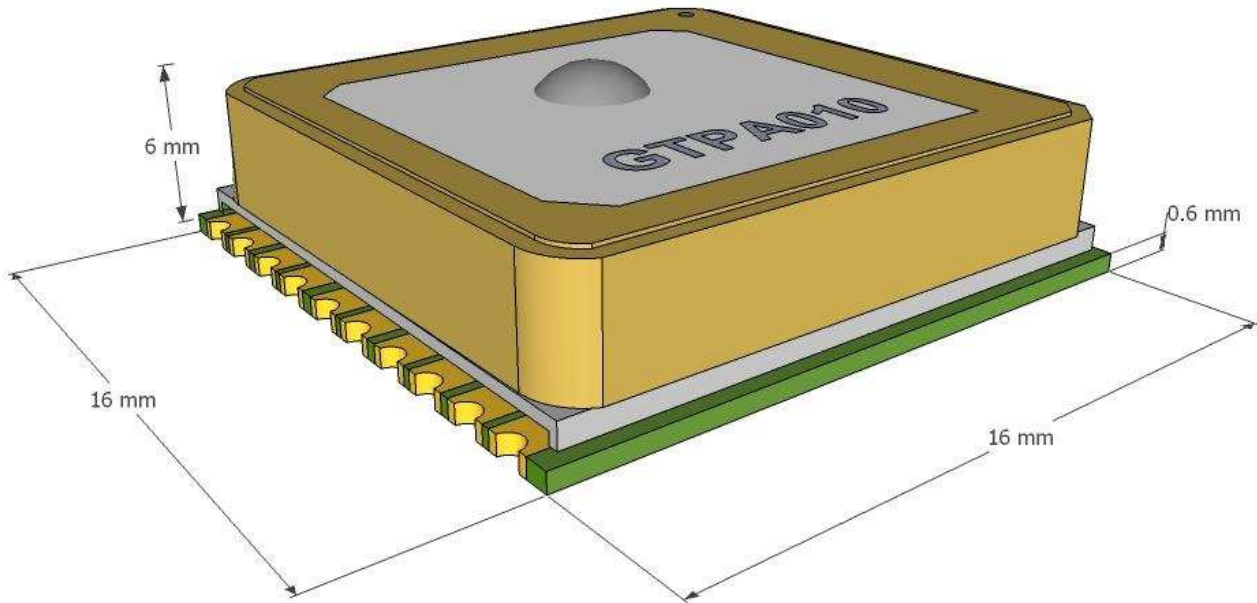

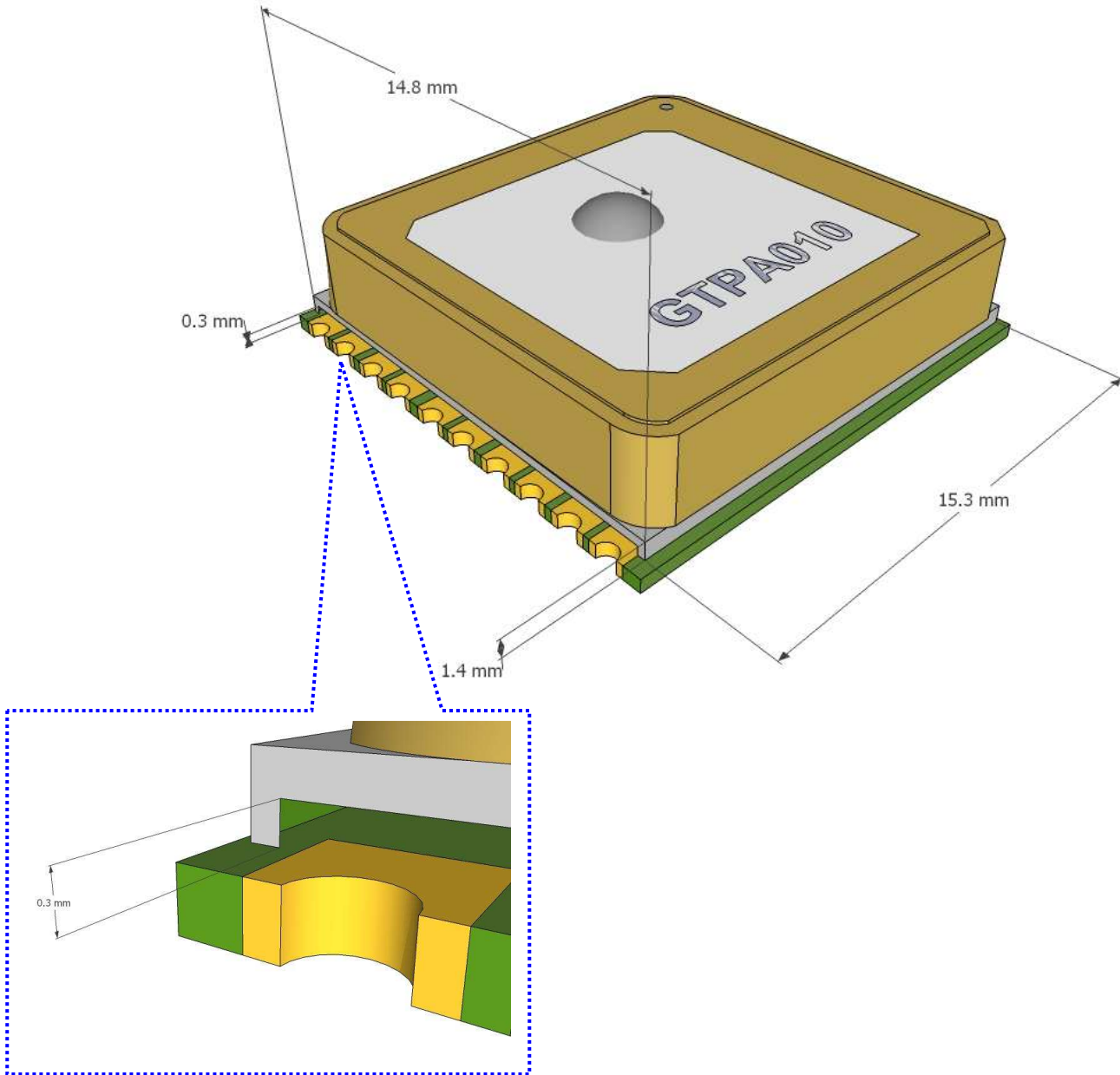

## 2.2 Recommended PCB pad Layout

(Unit: mm, Tolerance: 0.1mm)

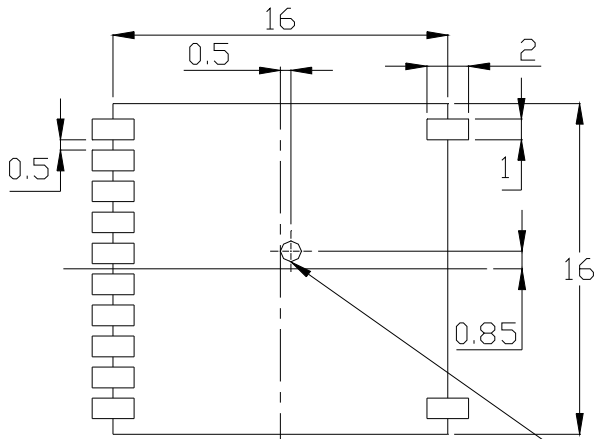

**Footprint Top View**

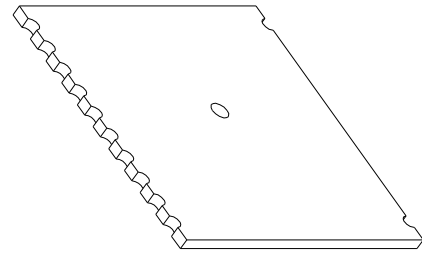

**No traces and vias are allowed to pass the area.**

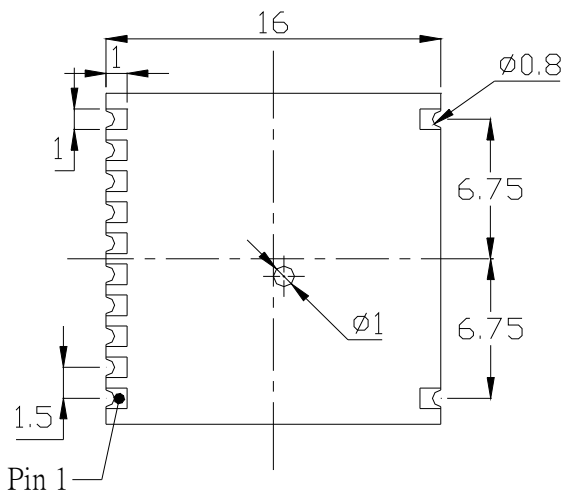
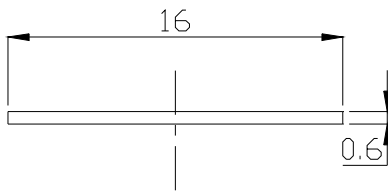

**PCB Bottom View**

**Unit: mm**



**Note:**

Place one hole (diameter =3.0mm)  
under this module for the antenna  
pad.

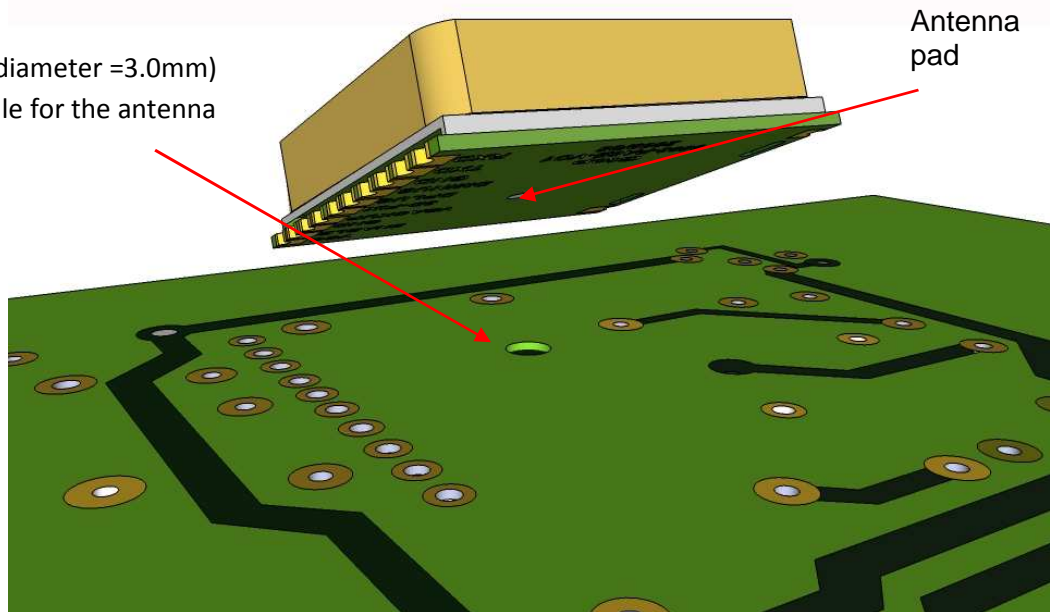

**Note:**

If can't place one hole on PCB for  
the antenna pad, don't let any  
trace and vias pass this area.

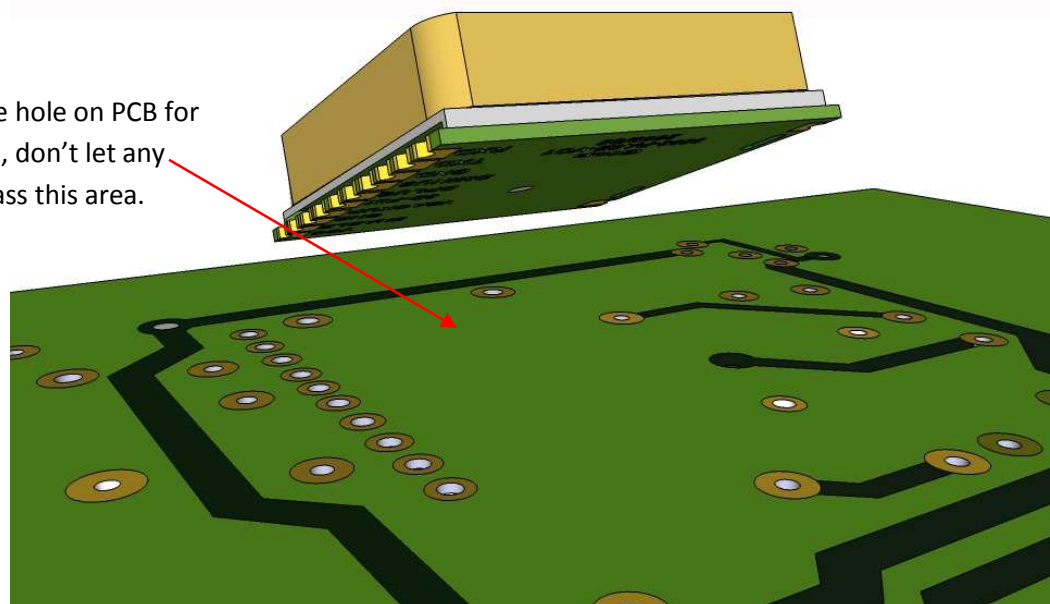

## 2.3 Pin Configuration

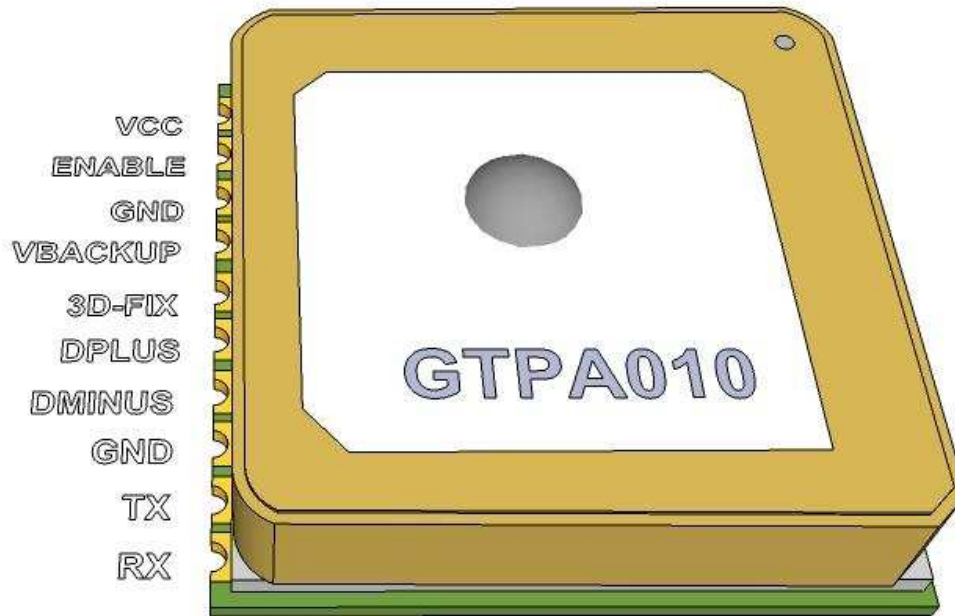

Top View

## 2.4 Pin Assignment

Pin	Name	I/O	Description
1	VCC	PI	Main DC power input
2	ENABLE	I	High active, or keep floating for normal working
3	GND	P	Ground
4	VBACKUP	PI	Backup power input
5	3D-FIX	O	3D-fix indicator
6	DPLUS	I/O	USB port D+
7	DMINUS	I/O	USB port D-
8	GND	P	Ground
9	TX	O	Serial data output of NMEA
10	RX	I	Serial data input for firmware update



## 2.5 Description of I/O Pin

### VCC (Pin1)

The main DC power supply of the module, the voltage should be kept between from 3.2V to 5.0V.

**The Vcc ripple must be controlled under 50mV<sub>pp</sub> (Typical: 3.3V)**

### ENABLE (Pin2)

Keep open or pull high to Power ON. Pull low to shutdown the module.

**Enable (High):  $1.8V \leq V_{enable} \leq VCC$**

**Disable (Low):  $0V \leq V_{enable} \leq 0.25V$**

### GND (Pin3)

Ground

### VBACKUP (Pin4)

This is the power for GPS chipset to keep RTC running when main power is removed. The voltage should be kept between 2.0V~4.3V. **(Typical: 3.0V)**

**The pin must be connected for normal operation.**

### 3D-FIX (Pin5)

The 3D-FIX is assigned as a fix flag output. The timing behavior of this pin can be configured by custom firmware for different applications (Example: waking up host MCU). If not used, keep floating.

- Before 2D Fix

The pin should continuously output one-second high-level with one-second low-level signal.

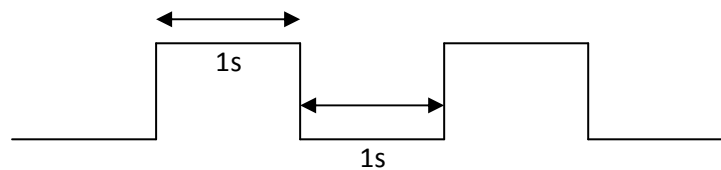

- After 2D or 3D Fix

The pin should continuously output low-level signal.

Low 

### DPLUS (Pin6)

USB Port DPLUS Signal

### DMINUS (Pin7)

USB Port DMINUS Signal

### GND (Pin8)

Ground

### TX (Pin9)

This is the UART transmitter of the module. It outputs the GPS information for application.

### RX (Pin10)

This is the UART receiver of the module. It is used to receive software commands and firmware update.

## 2.6 Specification List

<b>General</b>	
Chipset	MTK MT3329
Frequency	L1, 1575.42MHz
C/A Code	1.023 MHz
Channels	66 channels
SBAS	WAAS, EGNOS,MSAS ,GAGAN Supported(Default: Enable)
Datum	WGS84(Default), Tokyo-M, Tokyo-A, User Define
CPU	ARM7EJ-S
<b>Dimensions</b>	
Length/Width/Height	16*16*6 mm
Weight	6g
<b>Performance Characteristics</b>	
Position Accuracy	Without aid: 3m 2D-RMS
	DGPS(SBAS(WAAS,EGNOS,MSAS)):2.5m 2D-RMS
Velocity Accuracy	Without aid:0.1 m/s
	DGPS (SBAS ):0.05m/s
Acceleration Accuracy	Without aid:0.1 m/s <sup>2</sup>
	DGPS (SBAS ):0.05m/s <sup>2</sup>
Timing Accuracy	100 ns RMS
Sensitivity <sup>1</sup>	Acquisition:-148dBm (Cold Start)
	Reacquisition:-160dBm
	Tracking:-165dBm
Update Rate	1Hz (Default)
<b>Acquisition (Open sky, stationary)</b>	
Reacquisition Time <sup>1</sup>	Less than 1 second
Hot start <sup>1</sup>	1.0s (Typical)
Warm start <sup>1</sup>	34s (Typical)
Cold start <sup>1</sup>	35s (Typical)

<sup>1</sup> Reference to GPS chipset specification



<b>Dynamic</b>	
<b>Altitude</b>	Maximum 18,000m
<b>Velocity</b>	Maximum 515m/s
<b>Acceleration</b>	Maximum 4G
<b>I/O</b>	
<b>Signal Output</b>	8 data bits, no parity, 1 stop bit
<b>Available Baud Rates</b>	Default:9600bps (4800/9600/38400/57600/115200 bps by customization)
<b>Protocols</b>	NMEA 0183 v3.01 (Default: GGA,GSA,GSV,RMC,VTG) MTK NMEA Command
<b>Data output Interface</b>	
<b>USB Interface</b>	Logo certified USB 2.0 full-speed compatible
<b>UART Interface</b>	TTL level serial port
<b>Environment</b>	
<b>Operating Temperature</b>	-40 °C to 85 °C
<b>Storage Temperature</b>	-50 °C to 90 °C
<b>Operating Humidity</b>	5% to 95% (no condensing)
<b>Mounting</b>	SMD Type ,10 Pin

## 2.7 DC Characteristics

Parameter	Condition	Min.	Typ.	Max.	Unit	
Operation supply Voltage	—	3.2	3.3	5.0	V	
Operation supply Ripple Voltage	—	—	—	50	mVpp	
Backup Battery Voltage	—	2.0	3.0	4.3	V	
RX TTL H Level	VCC=3.2~5.0V	2.1	—	2.8	V	
RX TTL L Level	VCC=3.2~5.0V	0	—	0.9	V	
TX TTL H Level	VCC=3.2~5.0V	2.1	—	2.8	V	
TX TTL L Level	VCC=3.2~5.0V	0	—	0.8	V	
USB	Differential " 1 "	VCC=3.2~5.0V	(D+)-(D-) >200	—	—	mV
	Differential " 0 "	VCC=3.2~5.0V	(D-)-(D+) >200	—	—	mV
Power Consumption @ 3.3V, 1Hz Update Rate	Acquisition	43	48	53	mA	
	Tracking	32	37	42	mA	
Backup Power Consumption@ 3.0V	25°C	—	10	—	uA	
Shut-down Power Consumption (via enable pin)	25°C	—	15	—	uA	

## 3. Protocols

---

### 3.1 NMEA Output Sentences

**Table-1** A list of each of the NMEA output sentences specifically developed and defined by MTK for use within MTK products

Table-1: NMEA Output Sentence	
Option	Description
GGA	Time, position and fix type data.
GSA	GPS receiver operating mode, active satellites used in the position solution and DOP values.
GSV	The number of GPS satellites in view satellite ID numbers, elevation, azimuth, and SNR values.
RMC	Time, date, position, course and speed data. Recommended Minimum Navigation Information.
VTG	Course and speed information relative to the ground.



**GGA—Global Positioning System Fixed Data. Time, Position and fix related data**

**Table-2** contains the values for the following example :

\$GPGGA,064951.000,2307.1256,N,12016.4438,E,1,8,0.95,39.9,M,17.8,M,,\*65

Table-2: GGA Data Format			
Name	Example	Units	Description
Message ID	\$GPGGA		GGA protocol header
UTC Time	064951.000		hhmmss.sss
Latitude	2307.1256		ddmm.mmmm
N/S Indicator	N		N=north or S=south
Longitude	12016.4438		dddmm.mmmm
E/W Indicator	E		E=east or W=west
Position Fix Indicator	1		See <b>Table-3</b>
Satellites Used	8		Range 0 to 14
HDOP	0.95		Horizontal Dilution of Precision
MSL Altitude	39.9	meters	Antenna Altitude above/below mean-sea level
Units	M	meters	Units of antenna altitude
Geoidal Separation	17.8	meters	
Units	M	meters	Units of geoid separation
Age of Diff. Corr.		second	Null fields when DGPS is not used
Checksum	*65		
<CR> <LF>			End of message termination

Table-3: Position Fix Indicator	
Value	Description
0	Fix not available
1	GPS fix
2	Differential GPS fix

**GSA—GNSS DOP and Active Satellites**

**Table-4** contains the values for the following example :

\$GPGSA,A,3,29,21,26,15,18,09,06,10,,,,,2.32,0.95,2.11\*00

Table-4: GSA Data Format			
Name	Example	Units	Description
Message ID	\$GPGSA		GSA protocol header
Mode 1	A		See <b>Table-5</b>
Mode 2	3		See <b>Table-6</b>
Satellite Used	29		SV on Channel 1
Satellite Used	21		SV on Channel 2
....	....	....	....
Satellite Used			SV on Channel 12
PDOP	2.32		Position Dilution of Precision
HDOP	0.95		Horizontal Dilution of Precision
VDOP	2.11		Vertical Dilution of Precision
Checksum	*00		
<CR> <LF>			End of message termination

Table-5: Mode 1	
Value	Description
M	Manual—forced to operate in 2D or 3D mode
A	2D Automatic—allowed to automatically switch 2D/3D

Table-6: Mode 2	
Value	Description
1	Fix not available
2	2D (< 4 SVs used)
3	3D ( $\geq 4$ SVs used)

**GSV—GNSS Satellites in View**

**Table-7** contains the values for the following example :

\$GPGSV,3,1,09,29,36,029,42,21,46,314,43,26,44,020,43,15,21,321,39\*7D

\$GPGSV,3,2,09,18,26,314,40,09,57,170,44,06,20,229,37,10,26,084,37\*77

\$GPGSV,3,3,09,07,,,26\*73

Table-7: GSV Data Format			
Name	Example	Units	Description
Message ID	\$GPGSV		GSV protocol header
Number of Messages	3		Range 1 to 3 <i>(Depending on the number of satellites tracked, multiple messages of GSV data may be required.)</i>
Message Number1	1		Range 1 to 3
Satellites in View	09		
Satellite ID	29		Channel 1 (Range 1 to 32)
Elevation	36	degrees	Channel 1 (Maximum 90)
Azimuth	029	degrees	Channel 1 (True, Range 0 to 359)
SNR (C/No)	42	dBHz	Range 0 to 99, (null when not tracking)
....	....	....	....
Satellite ID	15		Channel 4 (Range 1 to 32)
Elevation	21	degrees	Channel 4 (Maximum 90)
Azimuth	321	degrees	Channel 4 (True, Range 0 to 359)
SNR (C/No)	39	dBHz	Range 0 to 99, (null when not tracking)
Checksum	*7D		
<CR> <LF>			End of message termination

## RMC—Recommended Minimum Navigation Information

**Table-8** contains the values for the following example :

\$GPRMC,064951.000,A,2307.1256,N,12016.4438,E,0.03,165.48,260406, 3.05,W,A\*55

Table-8: RMC Data Format			
Name	Example	Units	Description
Message ID	\$GPRMC		RMC protocol header
UTC Time	064951.000		hhmmss.sss
Status	A		A=data valid or V=data not valid
Latitude	2307.1256		ddmm.mmmm
N/S Indicator	N		N=north or S=south
Longitude	12016.4438		dddmm.mmmm
E/W Indicator	E		E=east or W=west
Speed over Ground	0.03	knots	
Course over Ground	165.48	degrees	True
Date	260406		ddmmyy
Magnetic Variation	3.05,W	degrees	E=east or W=west <b>(Need GlobalTop Customization Service)</b>
Mode	A		A= Autonomous mode D= Differential mode E= Estimated mode
Checksum	*55		
<CR> <LF>			End of message termination

### VTG—Course and speed information relative to the ground

Table-9 contains the values for the following example:

\$GPVTG,165.48,T,,M,0.03,N,0.06,K,A\*37

Table-9: VTG Data Format			
Name	Example	Units	Description
Message ID	\$GPVTG		VTG protocol header
Course	165.48	degrees	Measured heading
Reference	T		True
Course		degrees	Measured heading
Reference	M		<b>Magnetic (Need GlobalTop Customization Service)</b>
Speed	0.03	knots	Measured horizontal speed
Units	N		Knots
Speed	0.06	km/hr	Measured horizontal speed
Units	K		Kilometers per hour
Mode	A		A= Autonomous mode D= Differential mode E= Estimated mode
Checksum	*06		
<CR> <LF>			End of message termination

## 3.2 MTK NMEA Command Protocols

The complete MTK NMEA Command list document is available by request. Contact GlobalTop for more details.

#### Packet Type :

103 PMTK\_CMD\_COLD\_START

#### Packet Meaning:

Cold Start : Don't use Time, Position, Almanacs and Ephemeris data at re-start.

#### Example:

\$PMTK103\*30<CR><LF>

### 3.3 Firmware Customization Services

GlobalTop also offers flexible, value-adding GPS firmware customization services that maximizes the over system efficiencies and power consumptions. Latest functions like Binary Mode, 1-Sentence Output, Geo-fencing and Last Position Retention, please see our website at [www.gtop-tech.com](http://www.gtop-tech.com) under Products / GPS Modules / Software Services for more details.

**Note: Not all firmware customization services listed below are supported by Gmm-u5j. Please contact GlobalTop Sales or Technical Support for more details.**



**GlobalTop**  
GlobalTop Firmware Customization Services

**AGPS**  
fast position fix with preloaded ephemeris

**BINARY MODE**  
outputs position in binary format for increase efficiency

**PERIODIC MODE**  
saves battery by powering off unused components

**DISTANCE CALCULATION**  
calculates line of sight distance between receiver and other points of interest

**TIMING MODE**  
advanced 1 PPS control for synchronization equipments

**DATA LOGGER SOLUTION**  
turns GPS receiver into data logger with additional flash memory

**10 HZ UPDATE**  
fast refresh rate for high speed applications

**LAST POSITION RETENTION**  
outputs last known position coordinates after losing GPS satellite fix

**ONE SENTENCE**  
decreases calculation load on processor by simplifying output NMEA sentences

**MEDIATEK MT3329**

## 4. Reference Design

This chapter introduces the reference schematic design for the best performance. Additional tips and cautions on design are well documented on Application Note, which is available upon request.

### 4.1 Reference Design Circuit

#### USB Interface

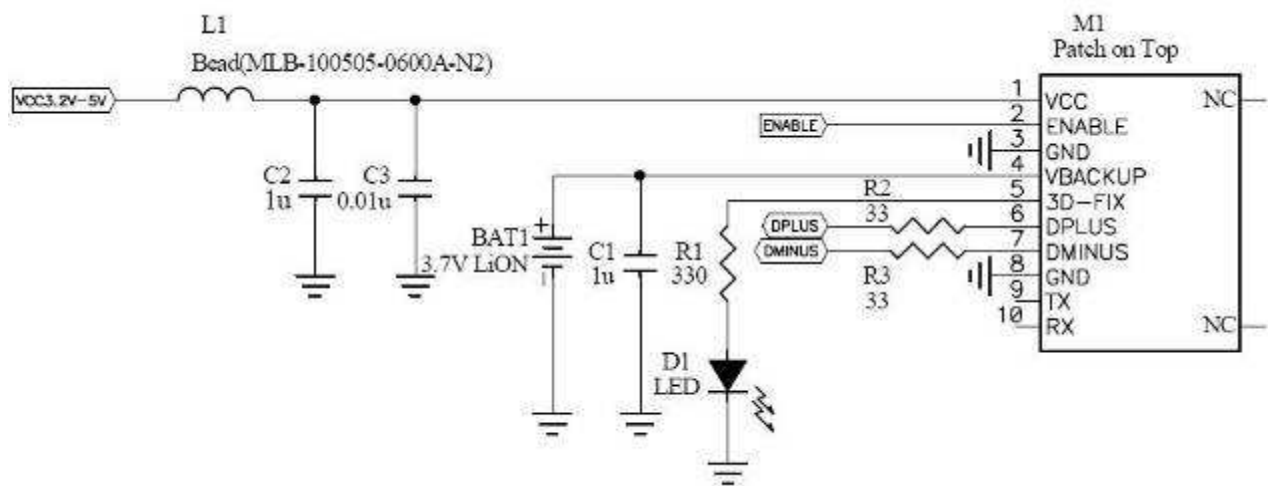

#### UART Interface

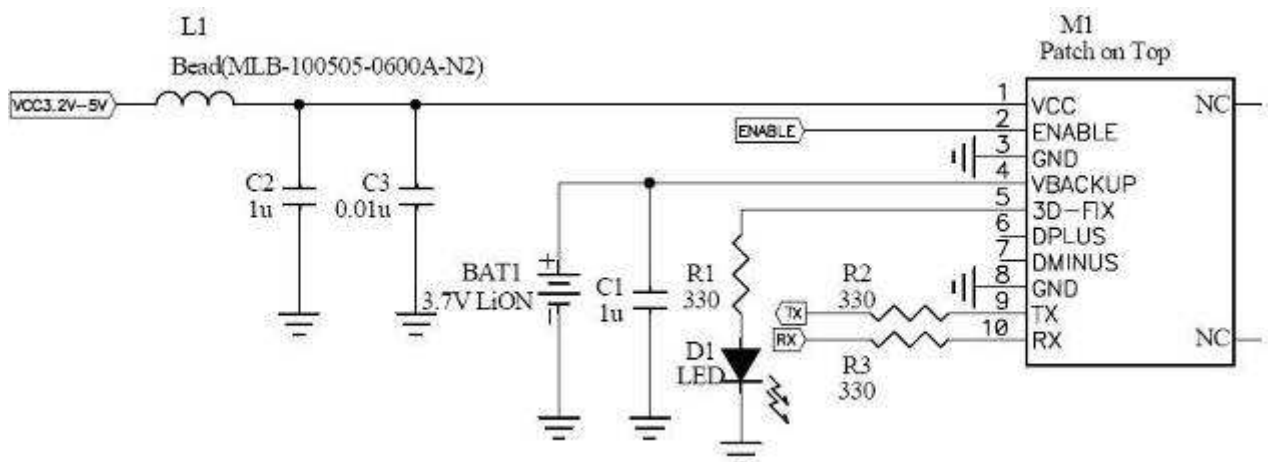

## 5. Packing and Handling

---

GPS modules, like any other SMD devices, are sensitive to moisture, electrostatic discharge, and temperature. By following the standards outlined in this document for GlobalTop GPS module storage and handling, it is possible to reduce the chances of them being damaged during production set-up. This document will go through the basics on how GlobalTop packages its modules to ensure they arrive at their destination without any damages and deterioration to performance quality, as well as some cautionary notes before going through the surface mount process.



**Please read the sections II to V carefully to avoid damages permanent damages due to moisture intake**



**GPS receiver modules contain highly sensitive electronic circuits and are electronic sensitive devices and improper handling without ESD protections may lead to permanent damages to the modules. Please read section VI for more details.**

### 5.1 Moisture Sensitivity

GlobalTop GPS modules are moisture sensitive, and must be pre-baked before going through the solder reflow process. It is important to know that:

**GlobalTop GPS modules must complete solder reflow process in 72 hours after pre-baking.**

This maximum time is otherwise known as “Floor Life”

If the waiting time has exceeded 72 hours, it is possible for the module to suffer damages during the solder reflow process such as cracks and delamination of the SMD pads due to excess moisture pressure.



## 5.2 Packing

GlobalTop GPS modules are packed in such a way to ensure the product arrives to SMD factory floor without any damages.

GPS modules are placed individually on to the packaging tray. The trays will then be stacked and packaged together.

Included are:

1. Two packs of desiccant for moisture absorption
2. One moisture level color coded card for relative humidity percentage.

Each package is then placed inside an antistatic bag (or PE bag) that prevents the modules from being damaged by electrostatic discharge.



Figure 1: One pack of GPS modules

Each bag is then carefully placed inside two levels of cardboard carton boxes for maximum protection.



Figure 2: Box protection

The moisture color coded card provides an insight to the relative humidity percentage (RH). When the GPS modules are taken out, it should be around or lower than 30% RH level.

Outside each electrostatic bag is a caution label for moisture sensitive device.

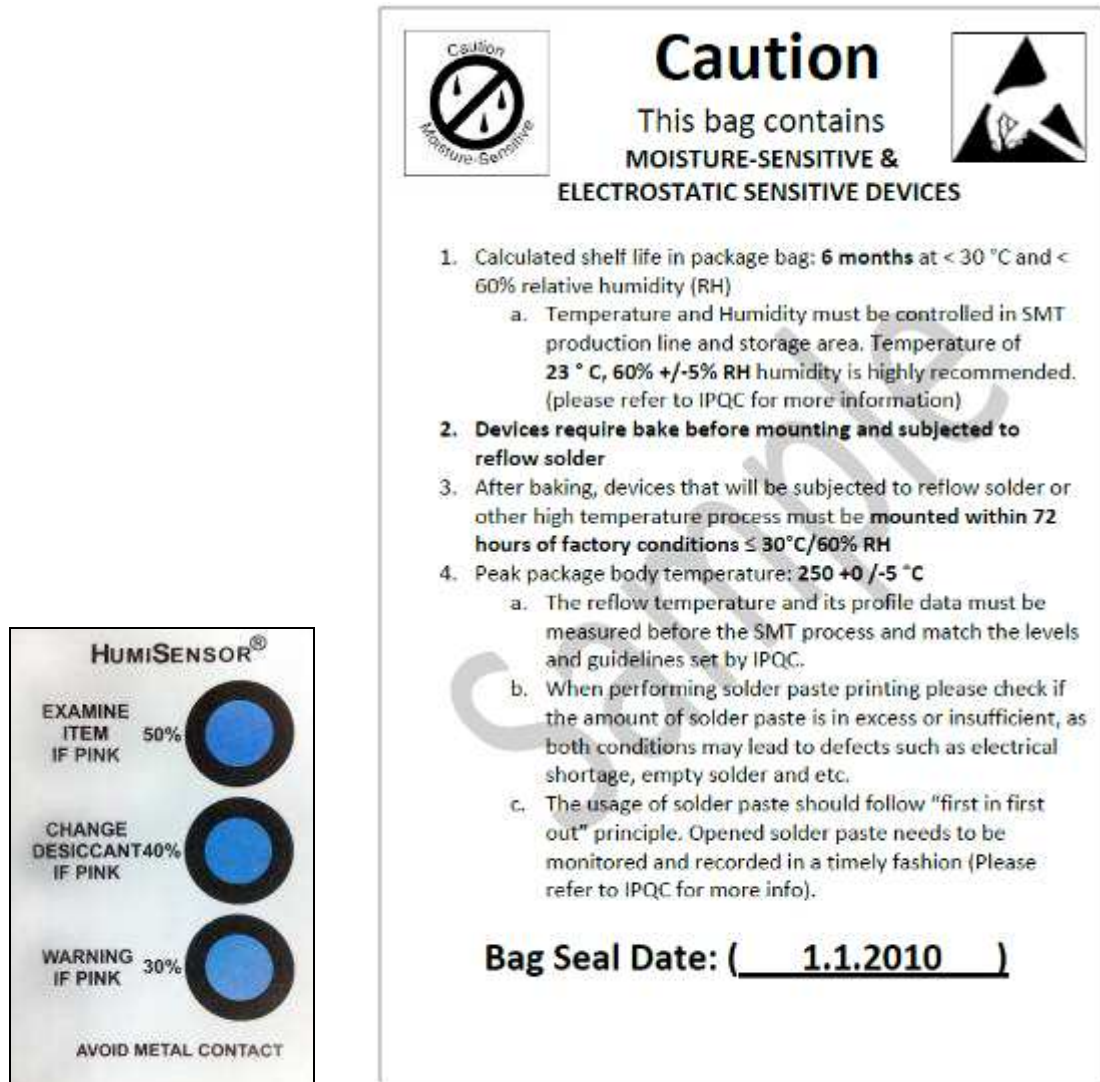

Figure 3: Example of moisture color coded card and caution label

## 5.3 Storage and Floor Life Guideline

Since GlobalTop modules must undergo solder-reflow process in 72 hours after it has gone through pre-baking procedure, therefore if it is not used by then, it is recommended to store the GPS modules in dry places such as dry cabinet.

The approximate shelf life for GlobalTop GPS modules packages is 6 months from the bag seal date, when store in a non-condensing storage environment (<30°C/60% RH)

 **It is important to note that it is a required process for GlobalTop GPS modules to undergo pre-baking procedures, regardless of the storage condition.**

## 5.4 Drying

Because the vapor pressures of moisture inside the GPS modules increase greatly when it is exposed to high temperature of solder reflow, in order to prevent internal delaminating, cracking of the devices, or the “popcorn” phenomenon, it is a **necessary requirement** for GlobalTop GPS module to undergo pre-baking procedure before any high temperature or solder reflow process.

The recommendation baking time for GlobalTop GPS module is as follows:

- ✓ **60°C for 8 to 12 hours**

Once baked, the module’s floor life will be “reset”, and has additional 72 hours in normal factory condition to undergo solder reflow process.

 **Please limit the number of times the GPS modules undergoes baking processes as repeated baking process has an effect of reducing the wetting effectiveness of the SMD pad contacts. This applies to all SMT devices.**

 **Oxidation Risk: Baking SMD packages may cause oxidation and/or intermetallic growth of the terminations, which if excessive can result in solderability problems during board assembly. The temperature and time for baking SMD packages are therefore limited by solderability considerations. The cumulative bake time at a temperature greater than 90°C and up to 125°C shall not exceed 96 hours. Bake temperatures higher than 125°C are now allowed.**

## 5.5 ESD Handling



**Please carefully follow the following precautions to prevent severe damage to GPS modules.**

GlobalTop GPS modules are sensitive to electrostatic discharges, and thus are Electrostatic Sensitive Devices (ESD). Careful handling of the GPS modules and in particular to its patch antenna (if included) and RF\_IN pin, must follow the standard ESD safety practices:

- ✓ Unless there is a galvanic coupling between the local GND and the PCB GND, then the first point of contact when handling the PCB shall always be between the local GND and PCB GND.
- ✓ Before working with RF\_IN pin, please make sure the GND is connected
- ✓ When working with RF\_IN pin, do not contact any charges capacitors or materials that can easily develop or store charges such as patch antenna, coax cable, soldering iron.
- ✓ Please do not touch the mounted patch antenna to prevent electrostatic discharge from the RF input
- ✓ When soldering RF\_IN pin, please make sure to use an ESD safe soldering iron (tip).

## 6. Reflow Soldering Temperature Profile

The following reflow temperature profile was evaluated by GlobalTop and has been proven to be reliable qualitatively. Please contact us beforehand if you plan to solder this component using a deviated temperature profile as it may cause significant damage to our module and your device.

All the information in this sheet can only be used only for Pb-free manufacturing process.

### 6.1 SMT Reflow Soldering Temperature Profile (Reference Only)

Reflow Condition (following JEDEC-020C)

Average ramp-up rate (217°C to peak): 3°C/sec. max.

Preheat: 150 ~ 200°C, 60 ~ 180 seconds

Temperature maintained above 217°C: 60~150 seconds

Time within 5°C of actual peak temperature: 20 ~ 40 seconds

Peak temperature: 250 +0/-5°C

Ramp-down rate: 6°C/sec. max.

Time 25°C to peak temperature: 8 minutes max.

Cycle Interval: 5 minutes

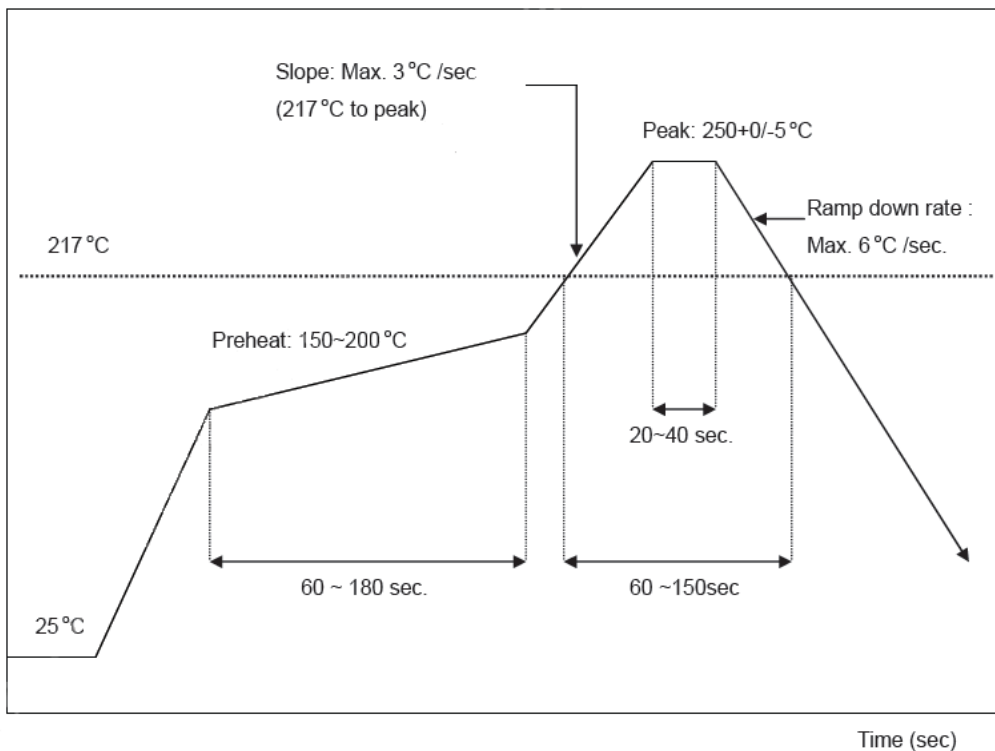

## 6.2 Cautions on Reflow Soldering with Patch Antenna

	Details	Suggestions	Notes
1	Before proceeding with the reflow-soldering process, the GPS module must be pre-baked.	Pre-bake Time: 6 Hours @ 60°±5°C or 4 Hours @ 70°±5°C	<b>The maximum tolerated temperature for the tray is 100°C.</b>  <b>After the pre-baking process, please make sure the temperature is sufficiently cooled down to 35°C or below in order to prevent any tray deformation.</b>
2	Because PCBA (along with the patch antenna) is highly endothermic during the reflow-soldering process, extra care must be paid to the GPS module's solder joint to see if there are any signs of cold weld(ing) or false welding.	The parameters of the reflow temperature must be set accordingly to module's reflow-soldering temperature profile.	<b>Double check to see if the surrounding components around the GPS module are displaying symptoms of cold weld(ing) or false welding.</b>
3	Special attentions are needed for PCBA board during reflow-soldering to see if there are any symptoms of bending or deformation to the PCBA board, possibility due to the weight of the module. If so, this will cause concerns at the latter half of the production process.	A loading carrier fixture must be used with PCBA if the reflow soldering process is using rail conveyors for the production.	<b>If there is any bending or deformation to the PCBA board, this might causes the PCBA to collide into one another during the unloading process.</b>
4	Before the PCBA is going through the reflow-soldering process, the production operators must check by eyesight to see if there are positional offset to the module, because it will be difficult to readjust after the module has gone through reflow-soldering process.	The operators must check by eyesight and readjust the position before reflow-soldering process.	<b>If the operator is planning to readjust the module position, please do not touch the patch antenna while the module is hot in order to prevent rotational offset between the patch antenna and module.</b>



	Details	Suggestions	Notes
5	Before handling the PCBA, they must be cooled to 35°C or below after they have gone through the reflow-soldering process, in order to prevent positional shift that might occur when the module is still hot.	<ol style="list-style-type: none"> <li>1. Can use electric fans behind the Reflow machine to cool them down.</li> <li>2. Cooling the PCBA can prevent the module from shifting due to fluid effect.</li> </ol>	<b>It is very easy to cause positional offset to the module and its patch antenna when handling the PCBA under high temperature.</b>
6	<ol style="list-style-type: none"> <li>1. When separating the PCBA panel into individual pieces using the V-Cut process, special attentions are needed to ensure there are sufficient gap between patch antennas so the patch antennas are not in contact with one another.</li> <li>2. If V-Cut process is not available and the pieces must be separated manually, please make sure the operators are not using excess force which may cause rotational offset to the patch antennas.</li> </ol>	<ol style="list-style-type: none"> <li>1. The blade and the patch antenna must have a distance gap greater than 0.6mm.</li> <li>2. Do not use patch antenna as the leverage point when separating the panels by hand.</li> </ol>	<ol style="list-style-type: none"> <li>1. <b>Test must be performed first to determine if V-Cut process is going to be used. There must be enough space to ensure the blade and patch antenna do not touch one another.</b></li> <li>2. <b>An uneven amount of manual force applied to the separation will likely to cause positional shift in patch antenna and module.</b></li> </ol>
7	When separating panel into individual pieces during latter half of the production process, special attentions are needed to ensure the patch antennas do not come in contact with one another in order to prevent chipped corners or positional shifts.	Use tray to separate individual pieces.	<b>It is possible to chip corner and/or cause a shift in position if patch antennas come in contact with each other.</b>

**Other Cautionary Notes on Reflow-Soldering Process:**

1. Module must be pre-baked **before** going through SMT solder reflow process.
2. The usage of solder paste should follow “first in first out” principle. Opened solder paste needs to be monitored and recorded in a timely fashion (can refer to IPQC for related documentation and examples).
3. Temperature and humidity must be controlled in SMT production line and storage area. Temperature of 23°C, 60±5% RH humidity is recommended. (please refer to IPQC for related documentation and examples)
4. When performing solder paste printing, please notice if the amount of solder paste is in excess or insufficient, as both conditions may lead to defects such as electrical shortage, empty solder and etc.
5. Make sure the vacuum mouthpiece is able to bear the weight of the GPS module to prevent positional shift during the loading process.
6. Before the PCBA is going through the reflow-soldering process, the operators should check by eyesight to see if there are positional offset to the module.
7. The reflow temperature and its profile data must be measured before the SMT process and match the levels and guidelines set by IPQC.
8. If SMT protection line is running a double-sided process for PCBA, please process GPS module during the second pass only to avoid repeated reflow exposures of the GPS module. This is because the patch antenna and its shielding on GPS module are endothermic and if the GPS module is already processed in the first pass, can result in the separation of the patch antenna and PCBA during the second pass due to gravitational pull. Please contact GlobalTop if you must process GPS module during the 1<sup>st</sup> pass of double-side process.

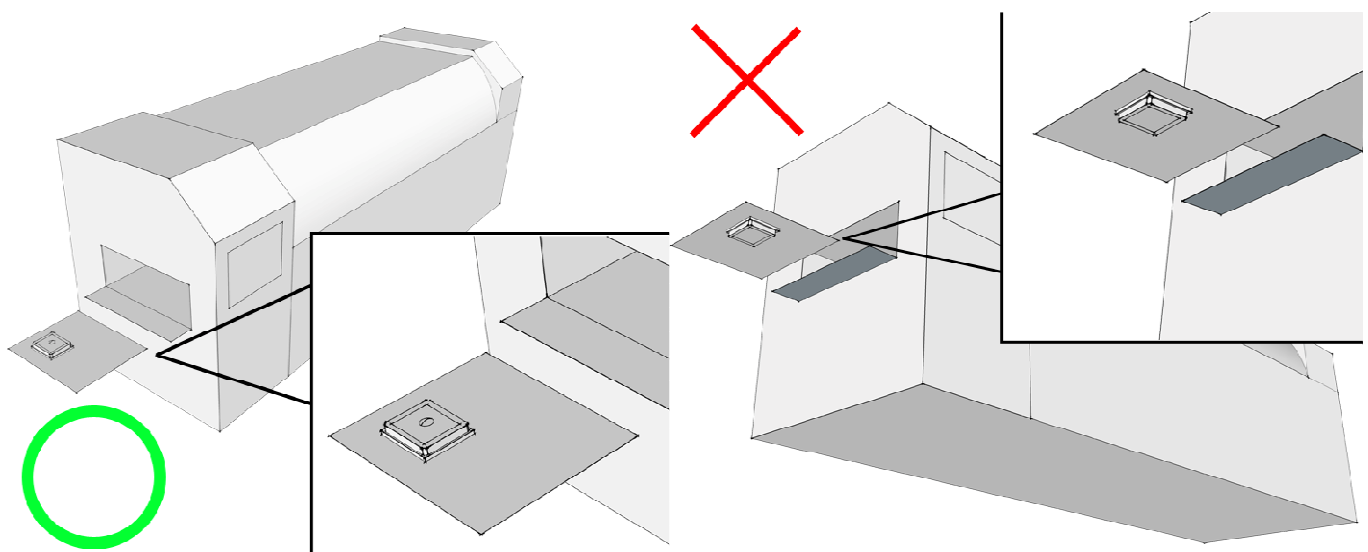

Figure 6.2: Place GPS module right-side up when running reflow-solder process, do not invert.



## 6.3 Manual Soldering

### Soldering iron:

Bit Temperature: Under 380°C      Time: Under 3 sec.

### Notes:

1. Please do not directly touch the soldering pads on the surface of the PCB board, in order to prevent further oxidation
2. The solder paste must be defrosted to room temperature before use so it can return to its optimal working temperature. The time required for this procedure is unique and dependent on the properties of the solder paste used.
3. The steel plate must be properly assessed before and after use, so its measurement stays strictly within the specification set by SOP.
4. Please watch out for the spacing between soldering joint, as excess solder may cause electrical shortage
5. Please exercise with caution and do not use extensive amount of flux due to possible siphon effects on neighboring components, which may lead to electrical shortage.
6. Please do not use the heat gun for long periods of time when removing the shielding or inner components of the GPS module, as it is very likely to cause a shift to the inner components and will leads to electrical shortage.

## 7. Contact Information

### GlobalTop Technology Inc.

**Address:** No.16 Nan-ke 9th Rd, Science-Based Industrial Park, Tainan, 741, Taiwan, R.O.C.

**Tel:** +886-6-505-1268

**Fax:** +886-6-505-3381

**Website:** [www.gtop-tech.com](http://www.gtop-tech.com)

**Email:** [sales@gtop-tech.com](mailto:sales@gtop-tech.com)